

D1 ADA SYMBOL
1 1/2" = 1'-0"

- 1/2" EXPANSION JOINT SPACING AT 50' AND AT STRUCTURES, DRIVES, AND OTHER WALKS.
- SIDEWALKS SHALL BE TOOLED AT LEAST 20% OF THE FULL DEPTH OF THE SIDEWALK AT 5' INTERVALS (MIN.) TO MAKE SQUARE SIZES. REFER TO JOINT PATTERN ON PLAN.
- ALL CONCRETE SHALL HAVE 4000 PSI MINIMUM COMPRESSIVE STRENGTH @ 28 DAYS

E2 TYPICAL SIDEWALK AND PAVEMENT DETAIL
3/4" = 1'-0"

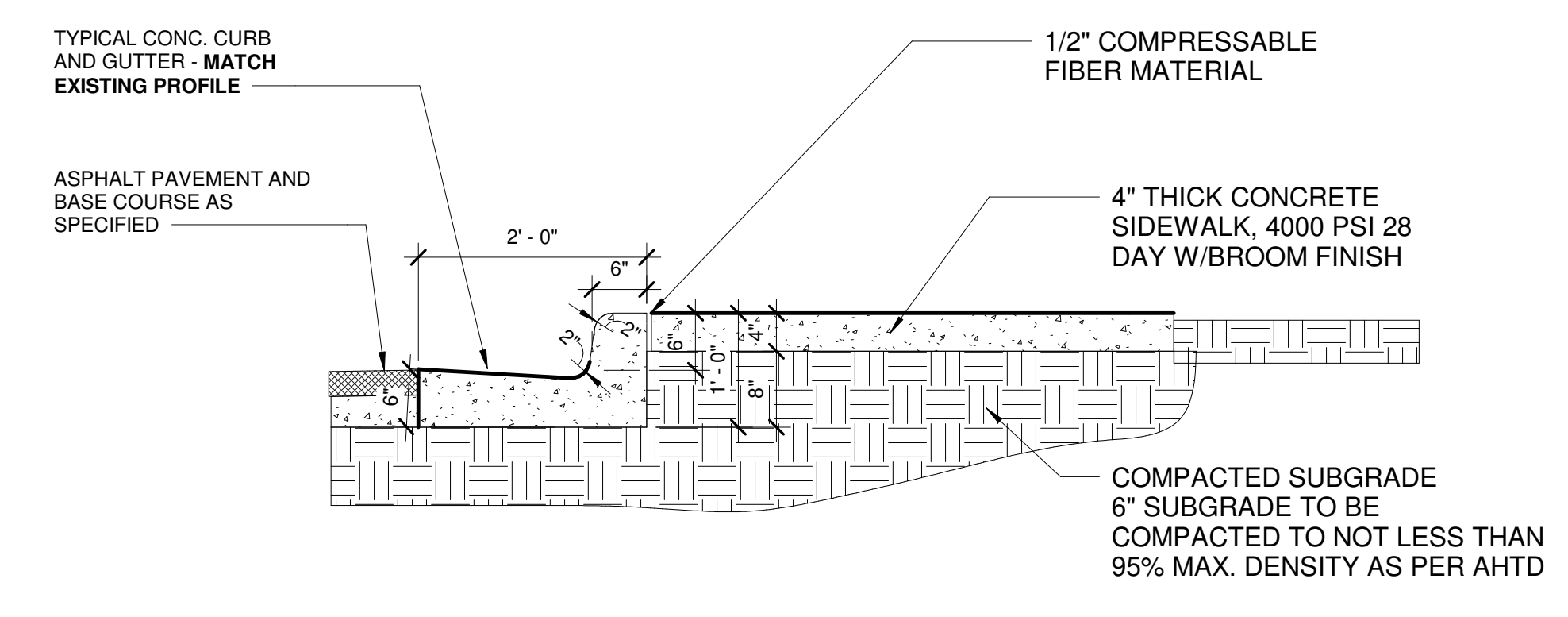

TYPICAL SIDEWALK SECTION

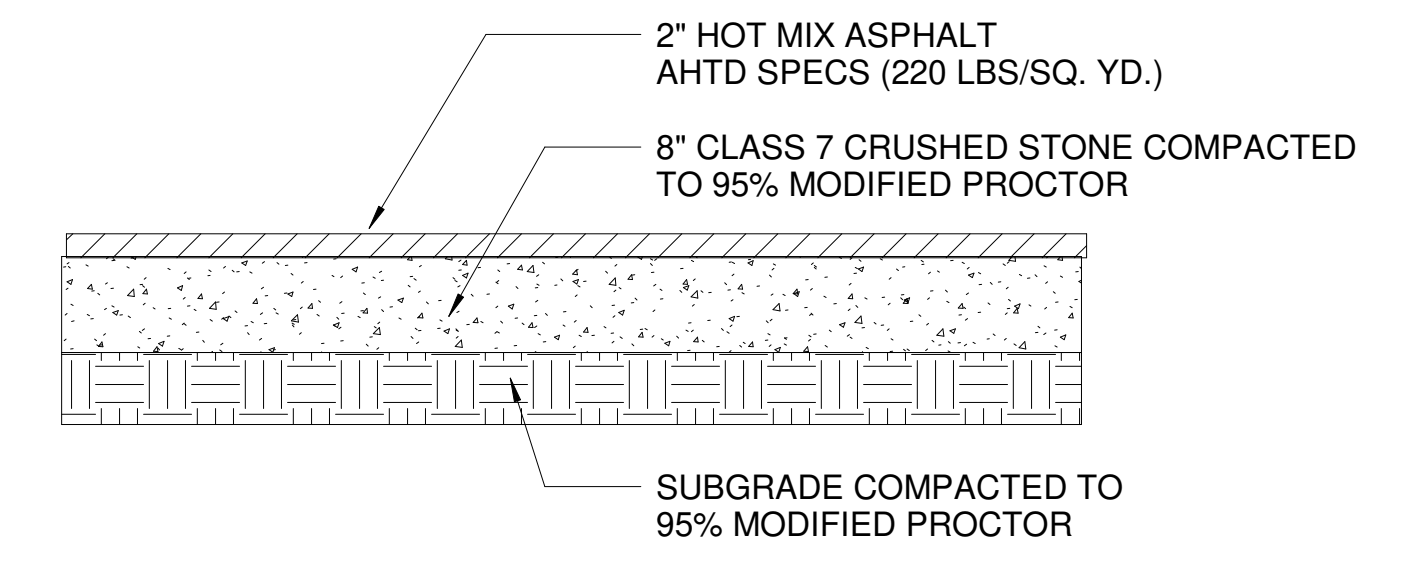

TYPICAL PAVEMENT SECTION - LIGHT DUTY



B1 ADA PARKING SIGN
1 1/2" = 1'-0"

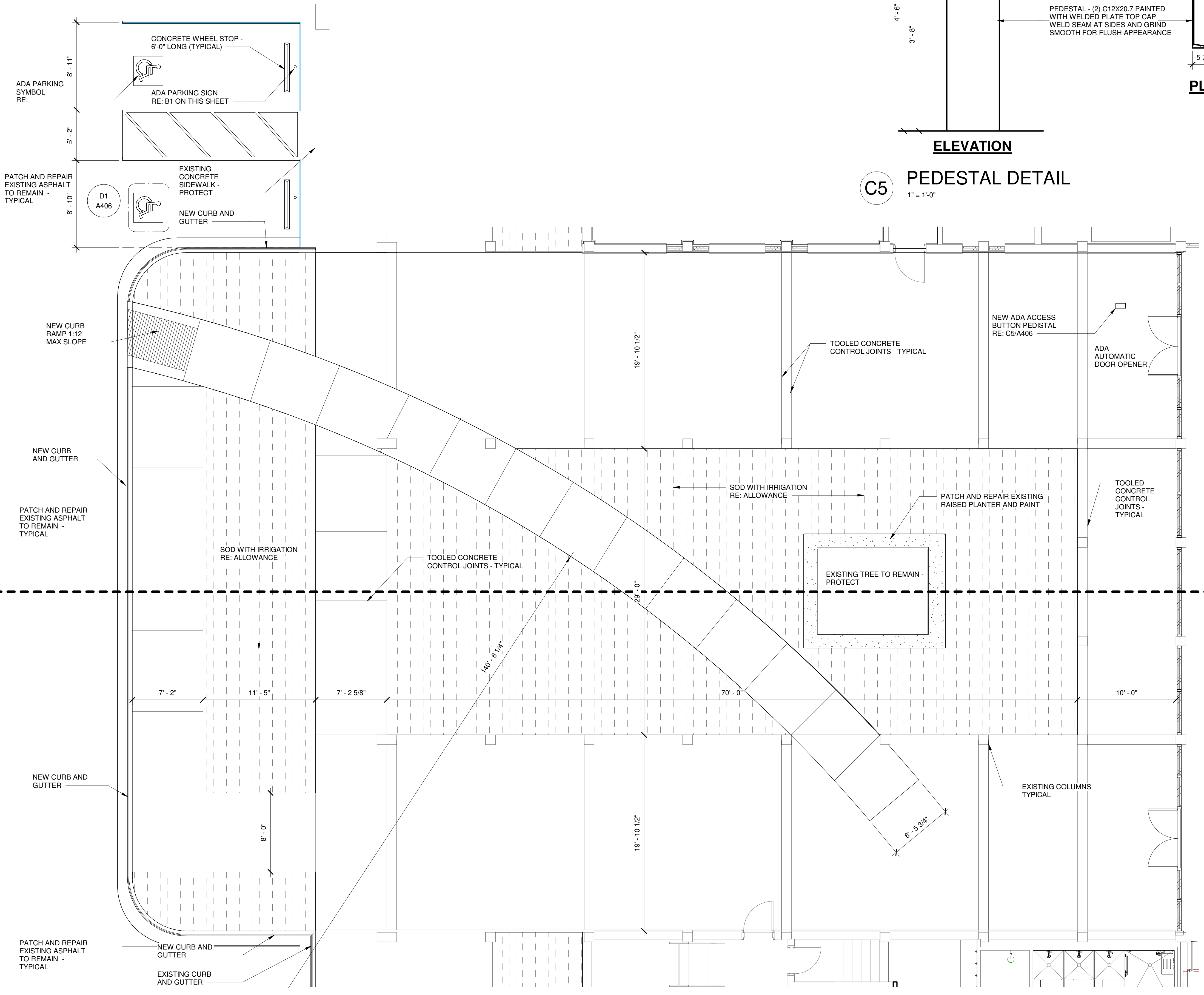

A2 ENLARGED COURTYARD PLAN
3/16" = 1'-0"

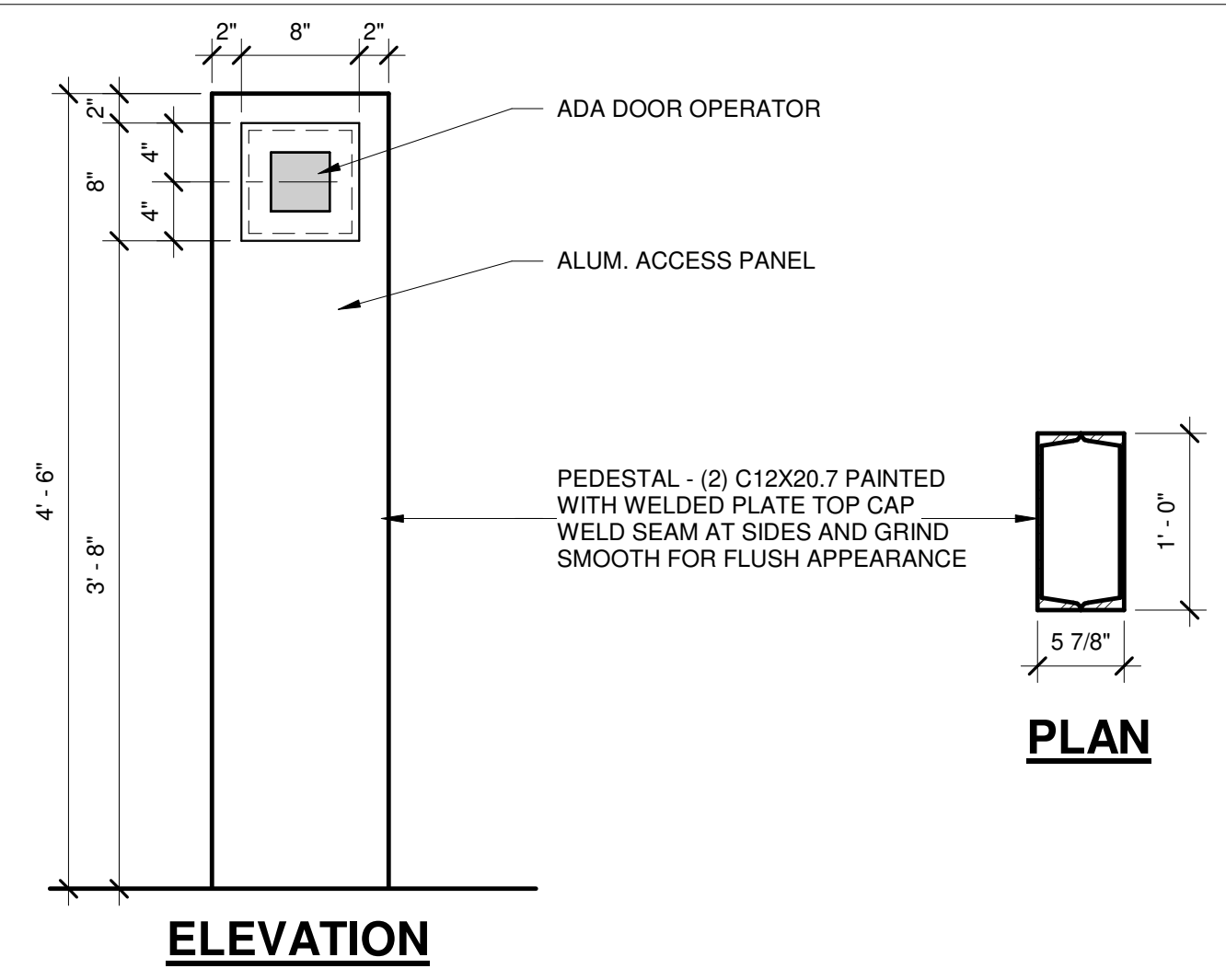

C5 PEDESTAL DETAIL
1" = 1'-0"



NO.	DESCRIPTION	DATE