

11/13/2023

HVAC SUBMITTAL REVIEW COMMENTS

#21068: Southside HS JR Additions

General Contractor: Nabholz
 HVAC Contractor: Comfort Systems

- | | |
|--|-----------------------|
| 1. Duct: | Approved |
| 2. Duct Sealant | Approved |
| 3. Kitchen Hood Systems | Approved |
| 4. Mini-Splits | Approved as corrected |
| a. Provide means for control by DDC system on ceiling cassettes. | |
| b. Coordinate electrical changes for DSCU1-1, 2-1, 2-2. | |
| 5. Residential Kitchen Hoods | Approved |
| 6. Welding Exhaust Drops | Approved |
| 7. Pipe Hanging and Support | Approved |
| 8. Identification | Approved |
| 9. TAB | Approved |
| 10. Insulation | Approved |
| 11. Controls | Approved |
| 12. Refrigerant Piping | Approved |
| 13. Take off fitting | Approved |
| 14. Fans | Approved |
| 15. Air Devices | Approved as corrected |
| a. V – provide insect screen. | |
| 16. Fabric Duct | Revise and Resubmit |
| a. Cfm's and lengths don't match plans. | |

Quality People. Building Solutions.

Comfort Systems USA (Arkansas), Inc.
P.O. Box 16620
Little Rock, AR 72231
Phone 501-834-3320
Fax 501-834-5416

Date: 8/11/2023

Return Request: 8/22/2023

Project: Southside HS & JH Additions

Supplier: Airetech/Middleton, Inc.

Manufacturer: Various

Submittal: HVAC Fans

Submittal Number: 23 34 00-01

Drawing # and Installation: Mechanical Drawings

ARCHITECT

Lewis Architects Engineers
11225 Huron Lane, Suite 104
Little Rock, AR 72211
501-223-9302

ENGINEER

Lewis Architects Engineers
11225 Huron Lane, Suite 104
Little Rock, AR 72211
501-223-9302

GENERAL CONTRACTOR

Nabholz
612 Garland St.
Conway, AR 72032
501-505-5800

MECHANICAL SUBCONTRACTOR

Comfort Systems USA (Arkansas), Inc.
9924 Landers Rd.
N. Little Rock, AR 72117
501-834-3320

Notes:

CSUSA PROJECT NO.

23-8009

dpierce@comfortar.com

9924 Landers Rd.
No. Little Rock, AR 72117



SUBMITTAL DATA

EQUIPMENT: HVAC Fans

SPEC SECTION: 23 34 00

TAGS: EF-1-1 thru WEF-1 and DEF-1

PROJECT: Southside High School and Junior High Additions

LOCATION: Batesville, AR

ENGINEER:



CONTRACTOR:



DATE: 7/26/2023

SUBMITTED BY: Forrest Moseley
forrest@airetechcorp.com
501-425-6112

Model: SP-B110

Ceiling Exhaust Fan

Tags: EF-1-1 EF-1-2 EF-1-3 EF-1-4 EF-1-5 EF-1-6 EF-1-7 EF-1-8 EF-1-9
 EF-1-18 EF-1-20 EF-1-22 EF-1-25 EF-1-26 EF-1-27 EF-1-28 EF-1-29 EF-1-30
 EF-2-2 EF-2-4

Standard Construction Features:

- Corrosion resistant galvanized steel scroll and housing - White designer non-yellowing grille - Round outlet duct collar with integral backdraft damper - Single inlet forward curved wheel - Plug type disconnect - Adjustable mounting brackets

Selected Options & Accessories:

Motor rated for continuous use
 Motor with Thermal Overload
 Motor with CSA Approval
 Motor with 40 Degree C Ambient Temperature
 UL/cUL 507 Listed - Electric Fan
 Solid State Speed Control, 6 Amp, Mounted and Wired Internally
 Round Duct Connection
 Transition Duct Reducer, (PN: 473324), Shipped Loose
 Isolation Kit, (PN: VI KIT-SP/CSP), Shipped Loose
 Adjustable easy installation mounting bracket
 Aluminum Grille with White Enamel Finish, (PN: 504879)
 Polypropylene Wheel Material
 Can Be Used to Comply with: ASHRAE 62.2 and Washington State Energy Code

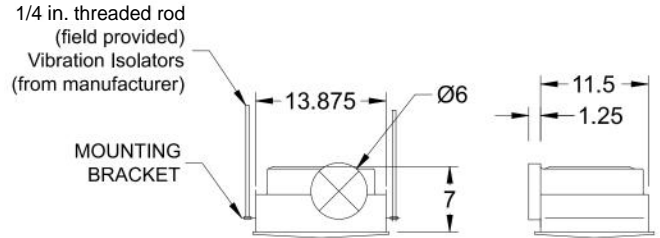
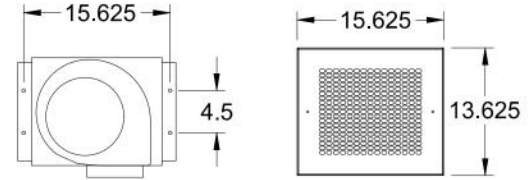

Dimensional	
Quantity	20
Weight w/o Acc's (lb)	10
Weight w/ Acc's (lb)	14

Performance	
Requested Volume (CFM)	75
Actual Volume (CFM)	75
Total External SP (in. wg)	0.3
Fan RPM	755
* FLA (A)	1.15
Elevation (ft)	256
Airstream Temp.(F)	70
Air Density (lb/ft3)	0.074
Sones	0.6

Motor	
Motor Mounted	Yes
** Input Watts (W)	80
Voltage/Cycle/Phase	115/60/1
Enclosure	ODP

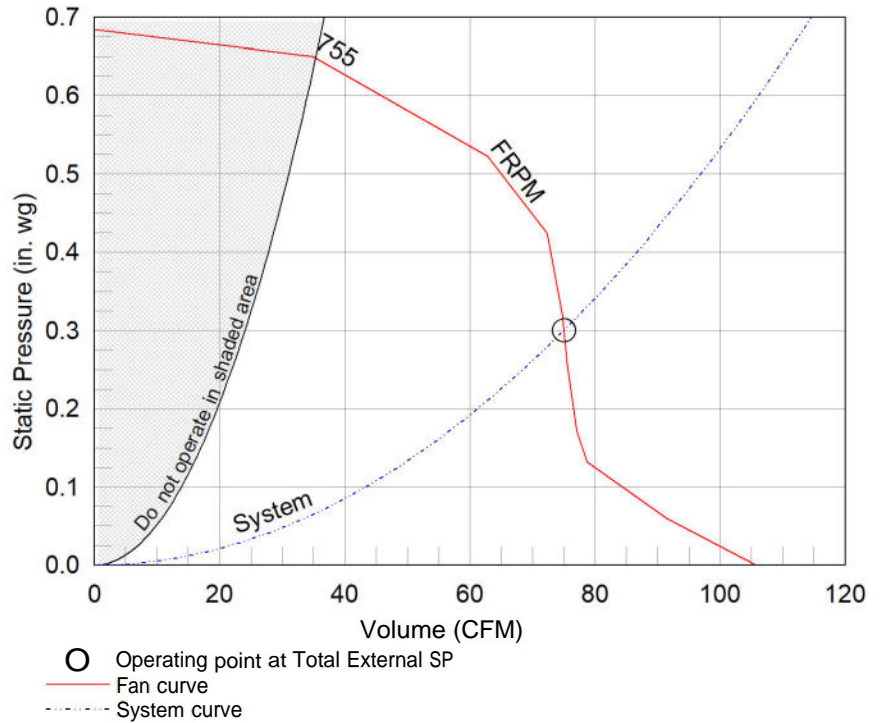

Notes:

All dimensions shown are in units of in.
 *FLA is approximate and will vary slightly with the motor.
 Sones - calculated using AMCA 301 at 5 ft
 ** Wattage is shown at free air.
 ** Wattage is approximate and may vary between motors.



Round Duct Connector

Model: RDC

Standard Construction Features:

-Constructed of Polypropylene - Replaces the square discharge duct connector and damper using the existing mounting holes

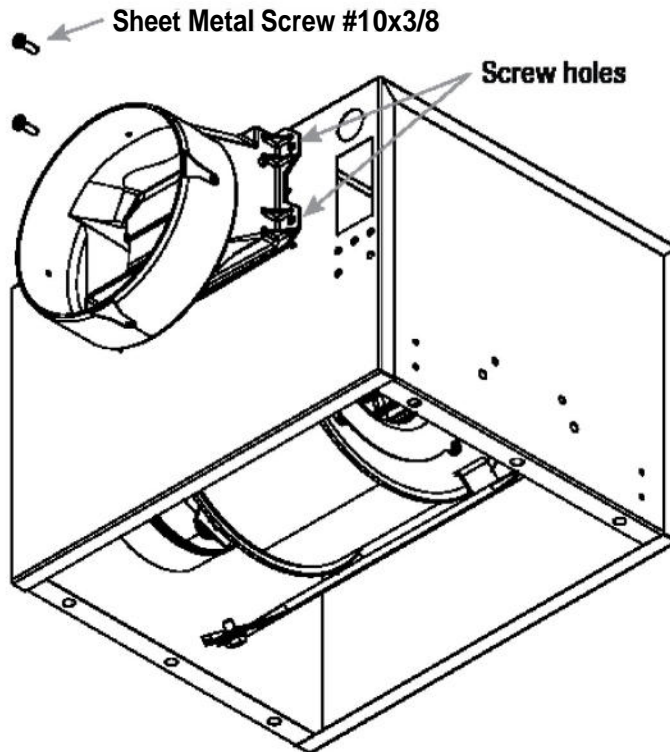

Notes: All dimensions shown are in units of in.

Isolation Kit

Type: Hanging

Standard Construction Features:

- Neoprene vibration isolation for hanging installation - Kit includes four isolators and all hardware necessary for mounting one unit except for the 0.25 in. x 20 in. threaded rod to be supplied by others - Fan mounting brackets include prepunched mounting holes for ease of installation

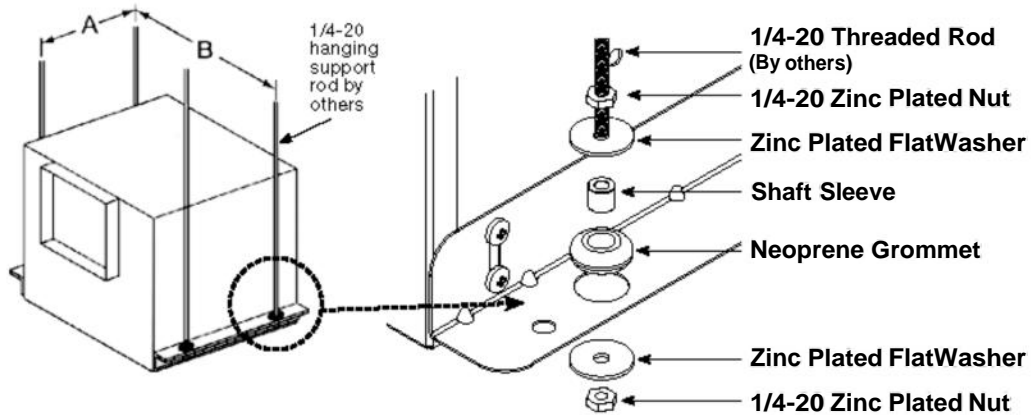

Unit Size	A	B
B50-B200	4 1/2 (114)	15 5/8 (397)
A50-A190	5 1/2 (140)	14 5/8 (371)
A200-A390	6 3/4 (171)	15 1/2 (394)
A410, A510, A710, A780	9 1/4 (235)	19 5/8 (498)
A700	5 1/2 (140)	25 1/8 (638)
A900-A1050, A1410-A1550	9 1/4 (235)	25 3/8 (645)
A1750, A2150	9 1/4 (235)	36 3/4 (933)
A3600	9 1/4 (235)	48 5/8(1235)
All dimensions shown in inches (millimeters).		

Description	Qty
Neoprene Grommets	4
1 x 32 Zinc Plated Nuts	8
Zinc Plated Flat Washers	8
3/8 x 3/16 Shaft Sleeves	4

6 to 4 Reducer

Model: TR 6X4

Standard Construction Features:

- The Round Transition reducer is constructed of a durable plastic material. It reduces the duct from 6 to 4 inches.

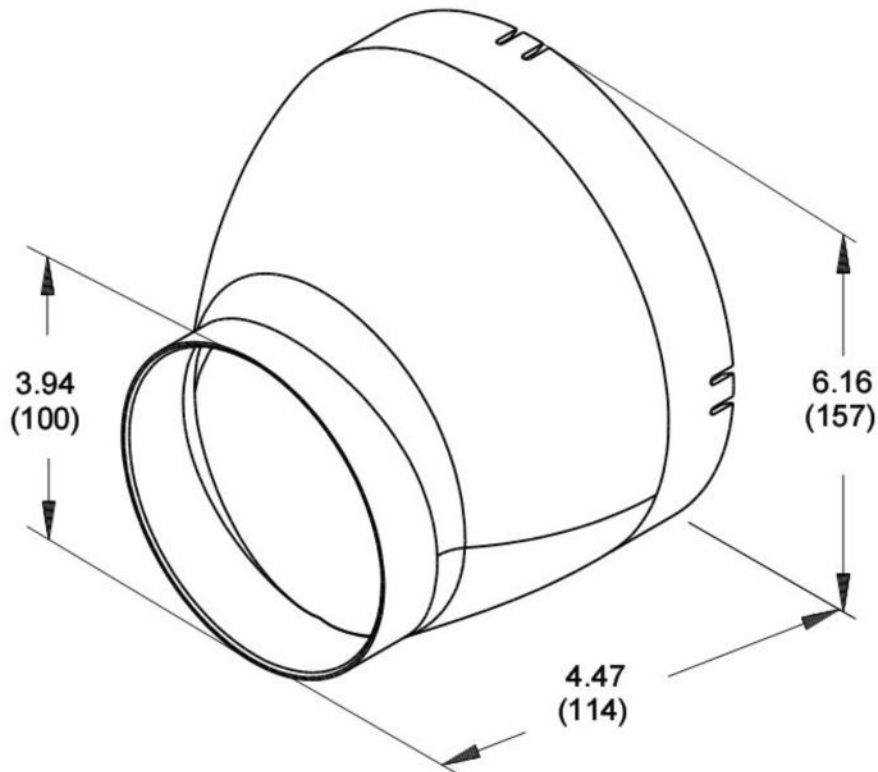

Notes: All dimensions shown are in units of in.

Model: SP-A390

Ceiling Exhaust Fan

Tags: EF-1-5 EF-1-6 EF-1-8 EF-1-13 EF-2-8

Standard Construction Features:

- Corrosion resistant galvanized steel scroll and housing
- Sound absorbing insulation
- White designer non-yellowing grille
- Rectangular outlet duct collar with integral spring loaded backdraft damper
- Double inlet forward curved wheel
- Plug type disconnect
- Adjustable mounting brackets
- Field rotatable discharge

Selected Options & Accessories:

- Motor rated for continuous use
- Motor with Thermal Overload
- Motor with CSA Approval
- Motor with 40 Degree C Ambient Temperature
- UL/cUL 507 Listed - Electric Fan
- Solid State Speed Control, 6 Amp, Mounted and Wired Internally
- Isolation Kit, (PN: VI KIT-SP/CSP), Shipped Loose
- Adjustable easy installation mounting bracket
- Aluminum Grille with White Enamel Finish, (PN: 504879)
- Polypropylene Wheel Material

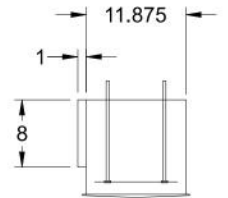
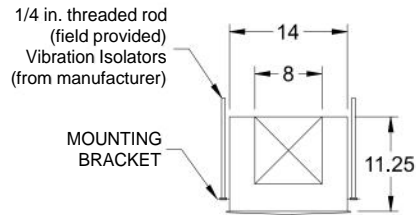
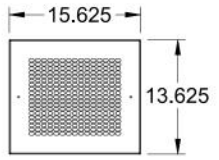
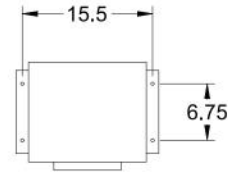

Dimensional	
Quantity	5
Weight w/o Acc's (lb)	24
Weight w/ Acc's (lb)	27

Performance	
Requested Volume (CFM)	300
Actual Volume (CFM)	300
Total External SP (in. wg)	0.3
Fan RPM	1184
* FLA (A)	1.42
Elevation (ft)	256
Airstream Temp.(F)	70
Air Density (lb/ft3)	0.074
Sones	3.0

Motor	
Motor Mounted	Yes
** Input Watts (W)	135
Voltage/Cycle/Phase	115/60/1
Enclosure	ODP

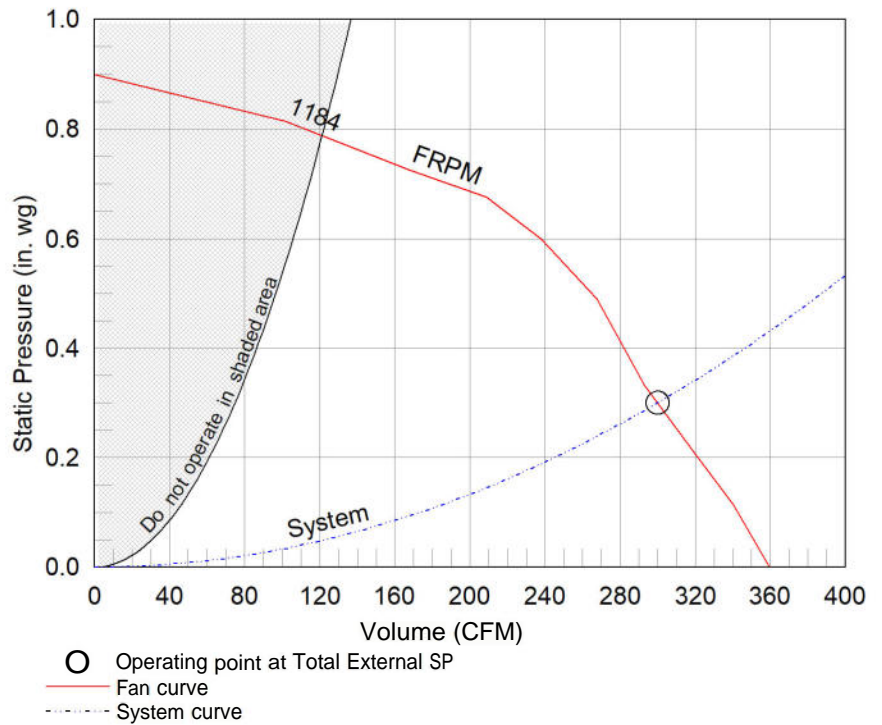

Notes:

- All dimensions shown are in units of in.
- *FLA is approximate and will vary slightly with the motor.
- Sones - calculated using AMCA 301 at 5 ft
- ** Wattage is shown at free air.
- ** Wattage is approximate and may vary between motors.



Isolation Kit

Type: Hanging

Standard Construction Features:

- Neoprene vibration isolation for hanging installation - Kit includes four isolators and all hardware necessary for mounting one unit except for the 0.25 in. x 20 in. threaded rod to be supplied by others - Fan mounting brackets include prepunched mounting holes for ease of installation

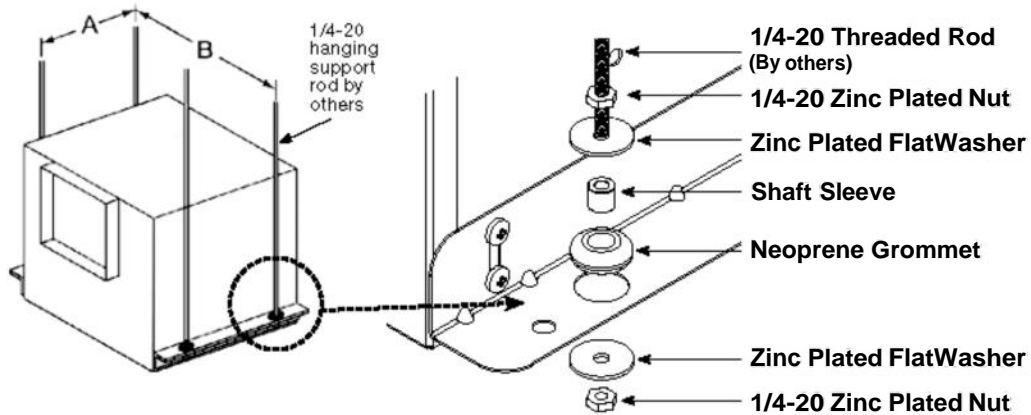

Unit Size	A	B
B50-B200	4 1/2 (114)	15 5/8 (397)
A50-A190	5 1/2 (140)	14 5/8 (371)
A200-A390	6 3/4 (171)	15 1/2 (394)
A410, A510, A710, A780	9 1/4 (235)	19 5/8 (498)
A700	5 1/2 (140)	25 1/8 (638)
A900-A1050, A1410-A1550	9 1/4 (235)	25 3/8 (645)
A1750, A2150	9 1/4 (235)	36 3/4 (933)
A3600	9 1/4 (235)	48 5/8(1235)
All dimensions shown in inches (millimeters).		

Description	Qty
Neoprene Grommets	4
1 x 32 Zinc Plated Nuts	8
Zinc Plated Flat Washers	8
3/8 x 3/16 Shaft Sleeves	4

Model: SP-A250

Ceiling Exhaust Fan

Tags: EF-1-14 EF-1-21 EF-2-9

Standard Construction Features:

- Corrosion resistant galvanized steel scroll and housing
- Sound absorbing insulation
- White designer non-yellowing grille
- Rectangular outlet duct collar with integral spring loaded backdraft damper
- Double inlet forward curved wheel
- Plug type disconnect
- Adjustable mounting brackets
- Field rotatable discharge

Selected Options & Accessories:

- Motor rated for continuous use
- Motor with Thermal Overload
- Motor with CSA Approval
- Motor with 40 Degree C Ambient Temperature
- UL/cUL 507 Listed - Electric Fan
- Solid State Speed Control, 6 Amp, Mounted and Wired Internally
- Isolation Kit, (PN: VI KIT-SP/CSP), Shipped Loose
- Adjustable easy installation mounting bracket
- Energy Star Certified
- Aluminum Grille with White Enamel Finish, (PN: 504879)
- Polypropylene Wheel Material
- Can Be Used to Comply with: ASHRAE 62.2, California Title 24, and Washington State Energy Code

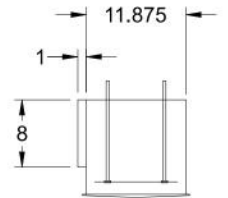
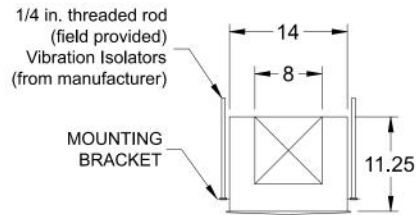
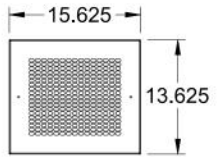
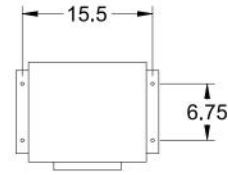

Dimensional	
Quantity	3
Weight w/o Acc's (lb)	24
Weight w/ Acc's (lb)	27

Performance	
Requested Volume (CFM)	225
Actual Volume (CFM)	225
Total External SP (in. wg)	0.3
Fan RPM	954
* FLA (A)	0.56
Elevation (ft)	256
Airstream Temp.(F)	70
Air Density (lb/ft3)	0.074
Sones	2.5

Motor	
Motor Mounted	Yes
** Input Watts (W)	83
Voltage/Cycle/Phase	115/60/1
Enclosure	ODP

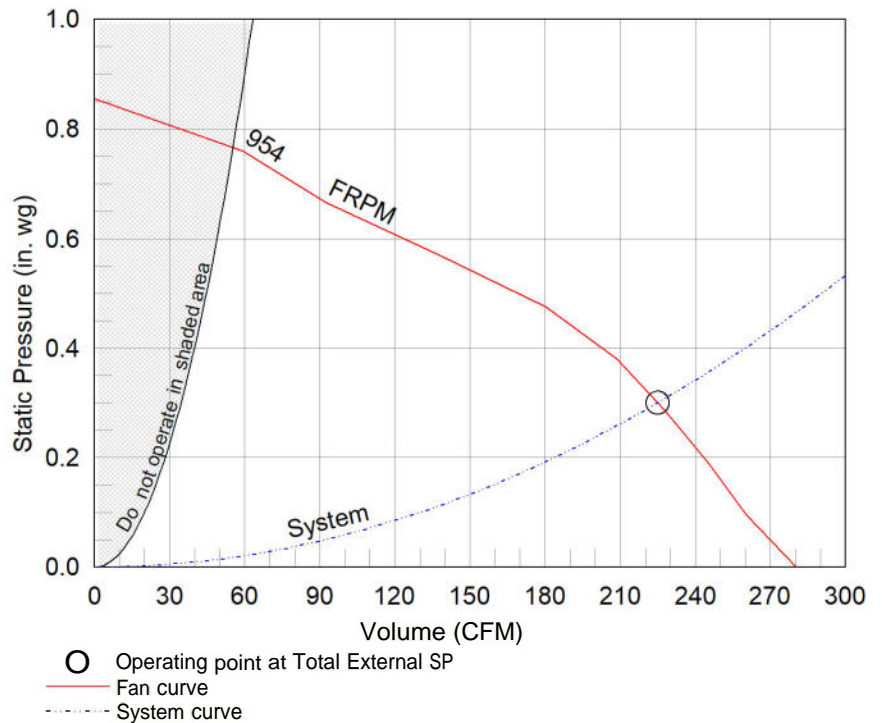

Notes:

- All dimensions shown are in units of in.
- *FLA is approximate and will vary slightly with the motor.
- Sones - calculated using AMCA 301 at 5 ft
- ** Wattage is approximate and may vary between motors.



Isolation Kit

Type: Hanging

Standard Construction Features:

- Neoprene vibration isolation for hanging installation - Kit includes four isolators and all hardware necessary for mounting one unit except for the 0.25 in. x 20 in. threaded rod to be supplied by others - Fan mounting brackets include prepunched mounting holes for ease of installation

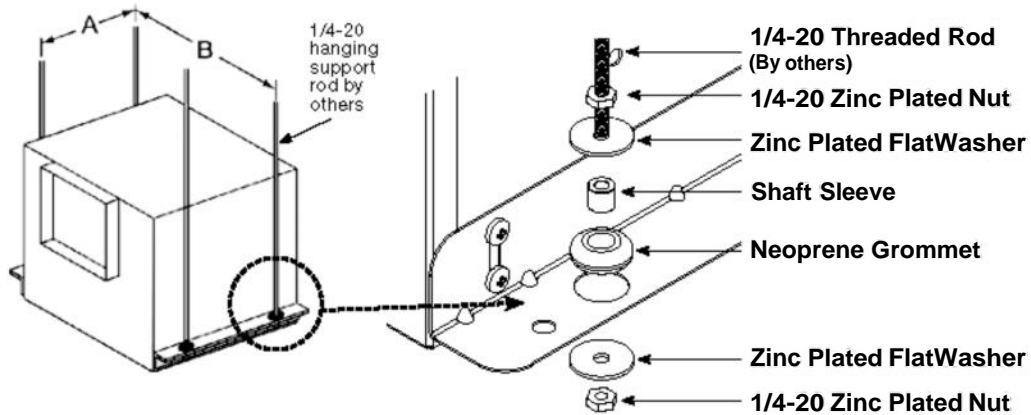

Unit Size	A	B
B50-B200	4 1/2 (114)	15 5/8 (397)
A50-A190	5 1/2 (140)	14 5/8 (371)
A200-A390	6 3/4 (171)	15 1/2 (394)
A410, A510, A710, A780	9 1/4 (235)	19 5/8 (498)
A700	5 1/2 (140)	25 1/8 (638)
A900-A1050, A1410-A1550	9 1/4 (235)	25 3/8 (645)
A1750, A2150	9 1/4 (235)	36 3/4 (933)
A3600	9 1/4 (235)	48 5/8(1235)
All dimensions shown in inches (millimeters).		

Description	Qty
Neoprene Grommets	4
1 x 32 Zinc Plated Nuts	8
Zinc Plated Flat Washers	8
3/8 x 3/16 Shaft Sleeves	4

Model: SP-A900

Ceiling Exhaust Fan

Tags: EF-1-15 EF-1-16 EF-1-17 EF-1-19 EF-2-1

Standard Construction Features:

- Galvanized steel housing - Sound absorbing insulation - White coated aluminum grille - Outlet duct collar with integral spring loaded backdraft damper - Dual forward curved wheels - Plug type disconnect - Adjustable mounting brackets - Square duct connection - Dual galvanized steel scroll design - Field rotatable discharge

Selected Options & Accessories:

- Motor rated for continuous use
- Motor with Thermal Overload
- Motor with CSA Approval
- Motor with 40 Degree C Ambient Temperature
- UL/cUL 507 Listed - Electric Fan
- Solid State Speed Control, 6 Amp, Mounted and Wired Internally
- Isolation Kit, (PN: VI KIT-SP/CSP), Shipped Loose
- Adjustable easy installation mounting bracket
- Aluminum Grille with White Enamel Finish
- Polypropylene Wheel Material

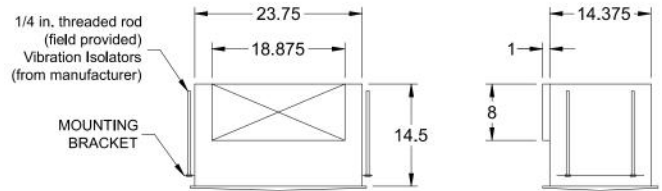
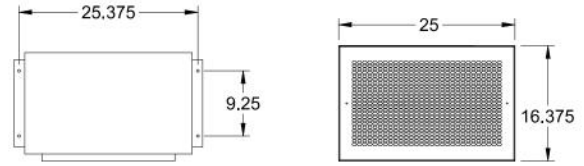

Dimensional	
Quantity	5
Weight w/o Acc's (lb)	56
Weight w/ Acc's (lb)	58

Performance	
Requested Volume (CFM)	525
Actual Volume (CFM)	525
Total External SP (in. wg)	0.3
Fan RPM	769
* FLA (A)	3.0
Elevation (ft)	256
Airstream Temp.(F)	70
Air Density (lb/ft3)	0.074
Sones	2.5

Motor	
Motor Mounted	Yes
** Input Watts (W)	301
Voltage/Cycle/Phase	115/60/1
Enclosure	ODP

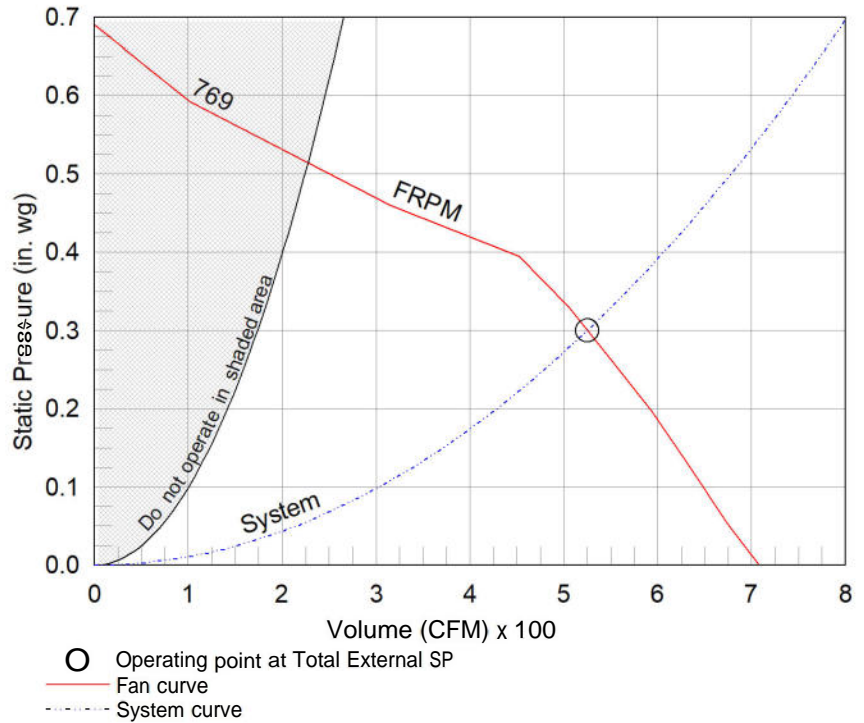

Notes:

- All dimensions shown are in units of in.
- *FLA is approximate and will vary slightly with the motor.
- Sones - calculated using AMCA 301 at 5 ft
- ** Wattage is shown at free air.
- ** Wattage is approximate and may vary between motors.



Isolation Kit

Type: Hanging

Standard Construction Features:

- Neoprene vibration isolation for hanging installation - Kit includes four isolators and all hardware necessary for mounting one unit except for the 0.25 in. x 20 in. threaded rod to be supplied by others - Fan mounting brackets include prepunched mounting holes for ease of installation

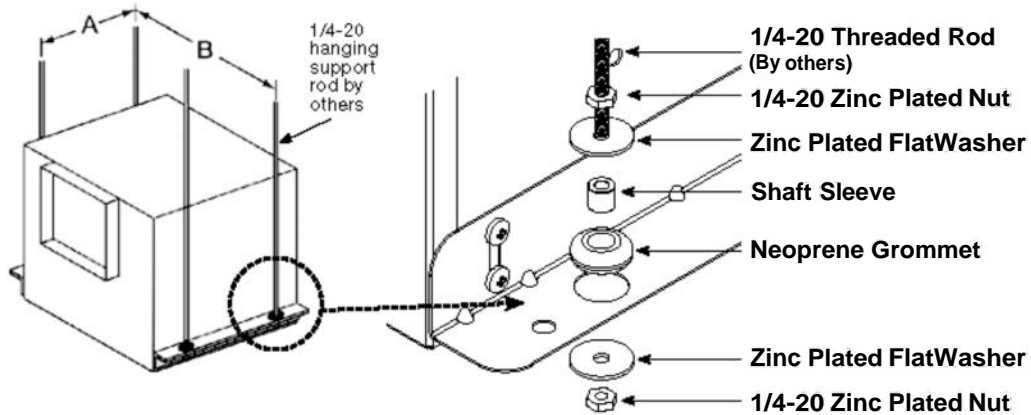

Unit Size	A	B
B50-B200	4 1/2 (114)	15 5/8 (397)
A50-A190	5 1/2 (140)	14 5/8 (371)
A200-A390	6 3/4 (171)	15 1/2 (394)
A410, A510, A710, A780	9 1/4 (235)	19 5/8 (498)
A700	5 1/2 (140)	25 1/8 (638)
A900-A1050, A1410-A1550	9 1/4 (235)	25 3/8 (645)
A1750, A2150	9 1/4 (235)	36 3/4 (933)
A3600	9 1/4 (235)	48 5/8(1235)
All dimensions shown in inches (millimeters).		

Description	Qty
Neoprene Grommets	4
1 x 32 Zinc Plated Nuts	8
Zinc Plated Flat Washers	8
3/8 x 3/16 Shaft Sleeves	4

Model: SP-A510

Ceiling Exhaust Fan

Tags: EF-1-23 EF-1-24 EF-2-3 EF-2-6 EF-2-7

Standard Construction Features:

- Galvanized steel housing - Sound absorbing insulation - White coated aluminum grille - Outlet duct collar with integral backdraft damper - Forward curved wheel - Plug type disconnect - Adjustable mounting brackets - Square duct connection - Field rotatable discharge

Selected Options & Accessories:

- Motor rated for continuous use
- Motor with Thermal Overload
- Motor with CSA Approval
- Motor with 40 Degree C Ambient Temperature
- UL/cUL 507 Listed - Electric Fan
- Solid State Speed Control, 6 Amp, Mounted and Wired Internally
- Isolation Kit, (PN: VI KIT-SP/CSP), Shipped Loose
- Adjustable easy installation mounting bracket
- Aluminum Grille with White Enamel Finish
- Polypropylene Wheel Material

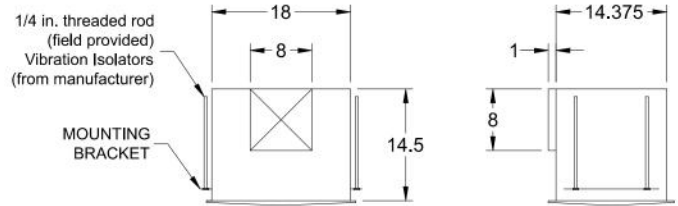
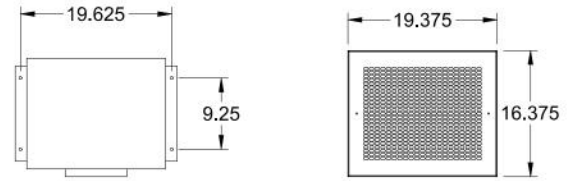

Dimensional	
Quantity	5
Weight w/o Acc's (lb)	31
Weight w/ Acc's (lb)	33

Performance	
Requested Volume (CFM)	375
Actual Volume (CFM)	375
Total External SP (in. wg)	0.3
Fan RPM	995
* FLA (A)	3.3
Elevation (ft)	256
Airstream Temp.(F)	70
Air Density (lb/ft3)	0.074
Sones	3.5

Motor	
Motor Mounted	Yes
** Input Watts (W)	224
Voltage/Cycle/Phase	115/60/1
Enclosure	ODP

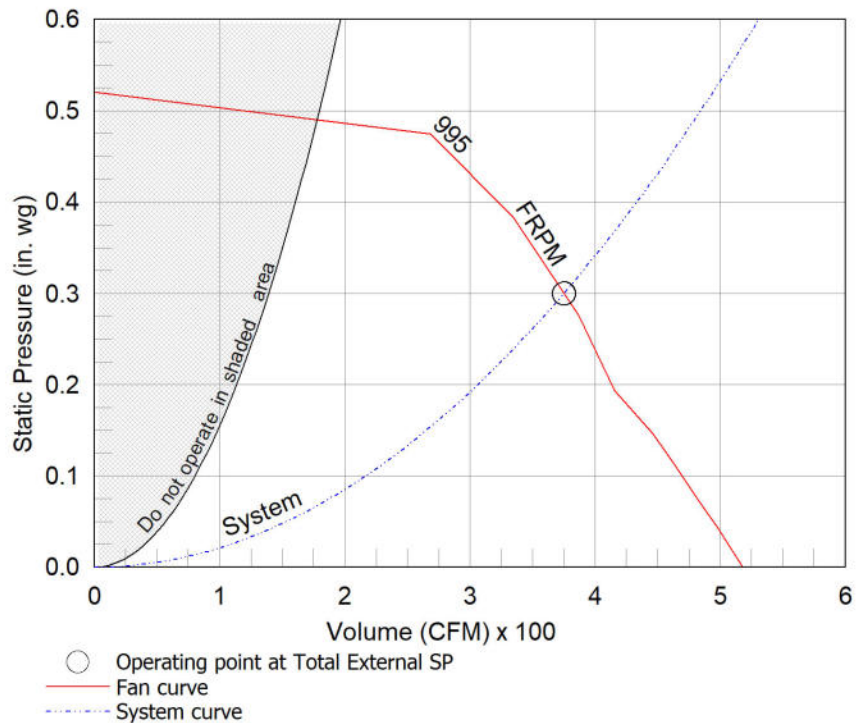

Notes:

- All dimensions shown are in units of in.
- *FLA is approximate and will vary slightly with the motor.
- Sones - calculated using AMCA 301 at 5 ft
- ** Wattage is shown at free air.
- ** Wattage is approximate and may vary between motors.



Isolation Kit

Type: Hanging

Standard Construction Features:

- Neoprene vibration isolation for hanging installation - Kit includes four isolators and all hardware necessary for mounting one unit except for the 0.25 in. x 20 in. threaded rod to be supplied by others - Fan mounting brackets include prepunched mounting holes for ease of installation

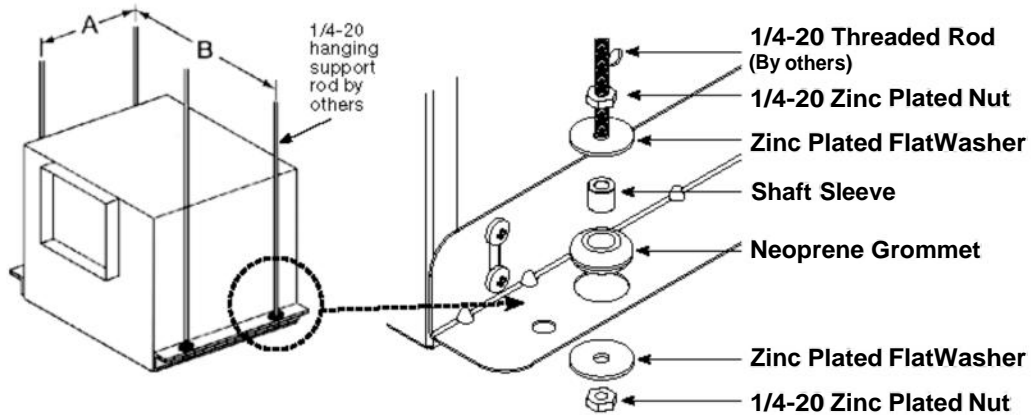

Unit Size	A	B
B50-B200	4 1/2 (114)	15 5/8 (397)
A50-A190	5 1/2 (140)	14 5/8 (371)
A200-A390	6 3/4 (171)	15 1/2 (394)
A410, A510, A710, A780	9 1/4 (235)	19 5/8 (498)
A700	5 1/2 (140)	25 1/8 (638)
A900-A1050, A1410-A1550	9 1/4 (235)	25 3/8 (645)
A1750, A2150	9 1/4 (235)	36 3/4 (933)
A3600	9 1/4 (235)	48 5/8(1235)
All dimensions shown in inches (millimeters).		

Description	Qty
Neoprene Grommets	4
1 x 32 Zinc Plated Nuts	8
Zinc Plated Flat Washers	8
3/8 x 3/16 Shaft Sleeves	4

Model: SP-B150

Ceiling Exhaust Fan

Standard Construction Features:

- Corrosion resistant galvanized steel scroll and housing - White designer non-yellowing grille - Round outlet duct collar with integral backdraft damper - Single inlet forward curved wheel - Plug type disconnect - Adjustable mounting brackets

Selected Options & Accessories:

Motor rated for continuous use
 Motor with Thermal Overload
 Motor with CSA Approval
 Motor with 40 Degree C Ambient Temperature
 UL/cUL 507 Listed - Electric Fan
 Solid State Speed Control, 6 Amp, Mounted and Wired Internally
 Round Duct Connection
 Transition Duct Reducer, (PN: 473324), Shipped Loose
 Isolation Kit, (PN: VI KIT-SP/CSP), Shipped Loose
 Adjustable easy installation mounting bracket
 Aluminum Grille with White Enamel Finish, (PN: 504879)
 Polypropylene Wheel Material
 Can Be Used to Comply with: ASHRAE 62.2 and Washington State Energy Code

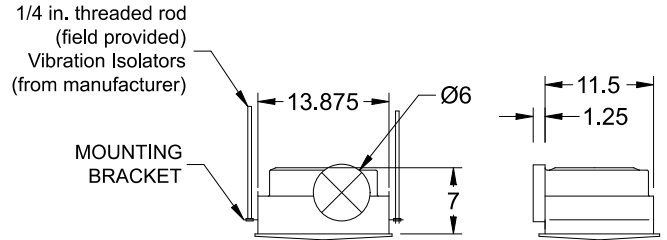
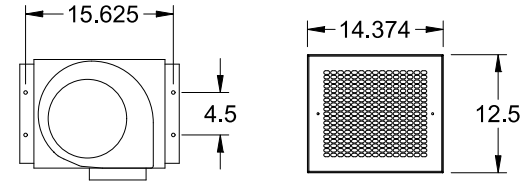

Dimensional	
Quantity	1
Weight w/o Acc's (lb)	10
Weight w/ Acc's (lb)	14

Performance	
Requested Volume (CFM)	100
Actual Volume (CFM)	100
Total External SP (in. wg)	0.3
Fan RPM	719
* FLA (A)	1.8
Elevation (ft)	256
Airstream Temp.(F)	70
Air Density (lb/ft3)	0.074
Sones	1.1

Motor	
Motor Mounted	Yes
** Input Watts (W)	128
Voltage/Cycle/Phase	115/60/1
Enclosure	ODP

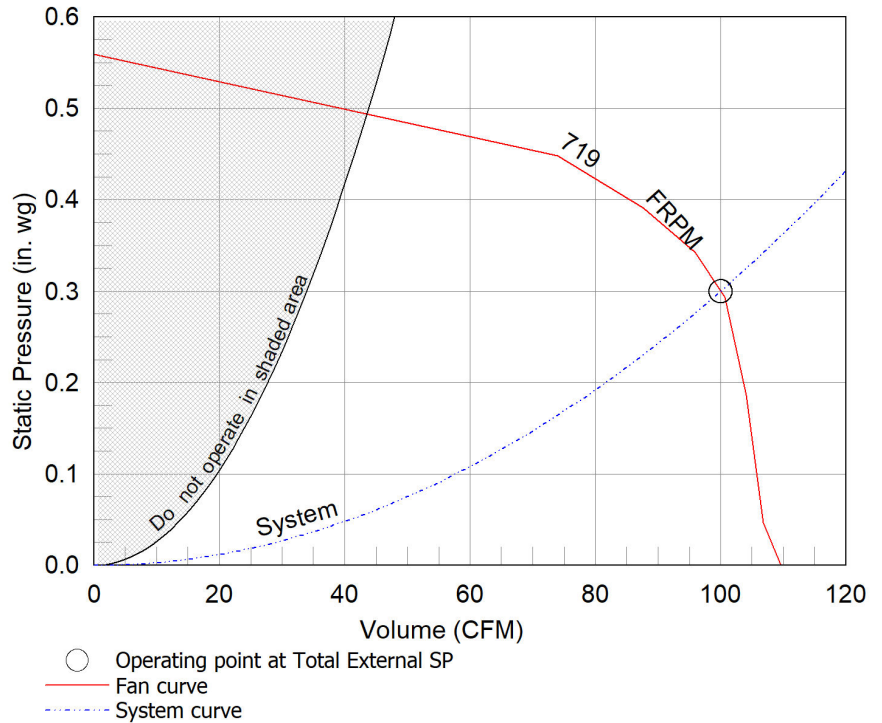

Notes:

All dimensions shown are in units of in.
 *FLA is approximate and will vary slightly with the motor.
 Sones - calculated using AMCA 301 at 5 ft
 ** Wattage is shown at free air.
 ** Wattage is approximate and may vary between motors.



Round Duct Connector

Model: RDC

Standard Construction Features:

-Constructed of Polypropylene - Replaces the square discharge duct connector and damper using the existing mounting holes

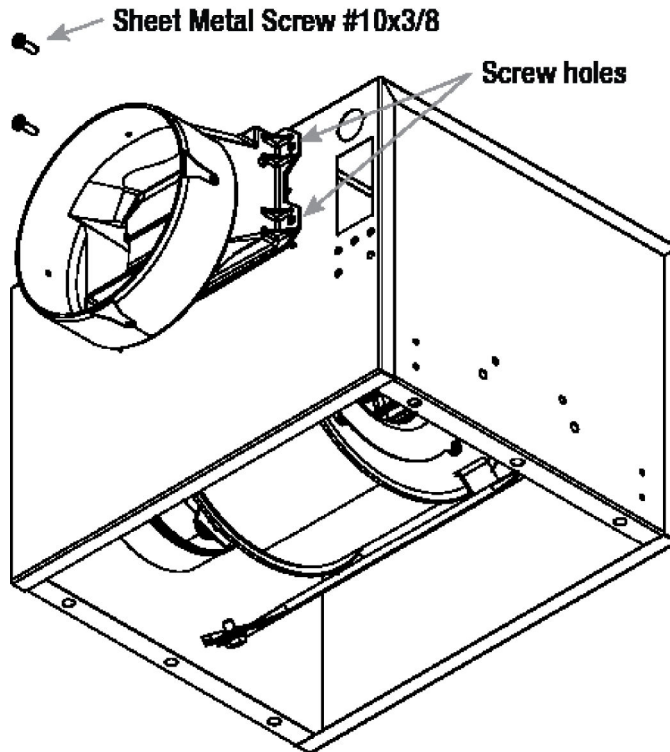

Notes: All dimensions shown are in units of in.

Isolation Kit

Type: Hanging

Standard Construction Features:

- Neoprene vibration isolation for hanging installation - Kit includes four isolators and all hardware necessary for mounting one unit except for the 0.25 in. x 20 in. threaded rod to be supplied by others - Fan mounting brackets include prepunched mounting holes for ease of installation

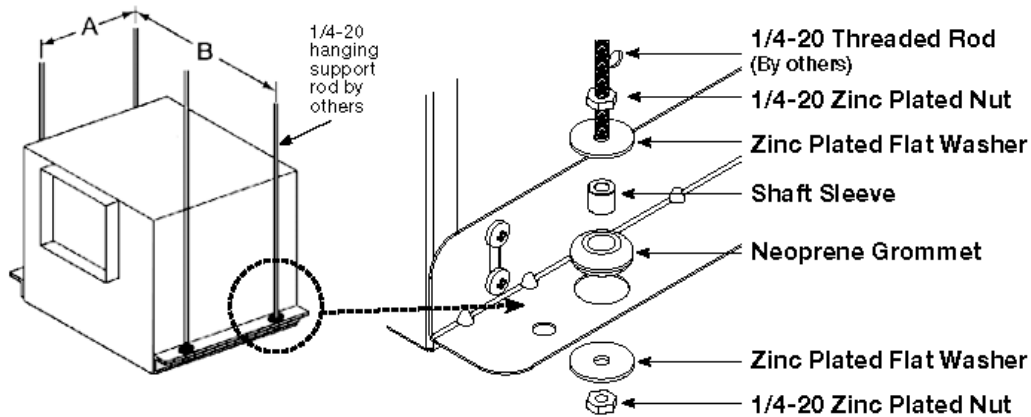

Unit Size	A	B
B50-B200	4 1/2 (114)	15 5/8 (397)
A50-A190	5 1/2 (140)	14 5/8 (371)
A200-A390	6 3/4 (171)	15 1/2 (394)
A410, A510, A710, A780	9 1/4 (235)	19 5/8 (498)
A700	5 1/2 (140)	25 1/8 (638)
A900 - A1050, A1410 - A1550	9 1/4 (235)	25 3/8 (645)
A1750, A2150	9 1/4 (235)	36 3/4 (933)
A3600	9 1/4 (235)	48 5/8 (1235)
All dimensions shown in inches (millimeters).		

Description	Qty
Neoprene Grommets	4
1 x 32 Zinc Plated Nuts	8
Zinc Plated Flat Washers	8
3/8 x 3/16 Shaft Sleeves	4

6 to 4 Reducer

Model: TR 6X4

Standard Construction Features:

- The Round Transition reducer is constructed of a durable plastic material. It reduces the duct from 6 to 4 inches.

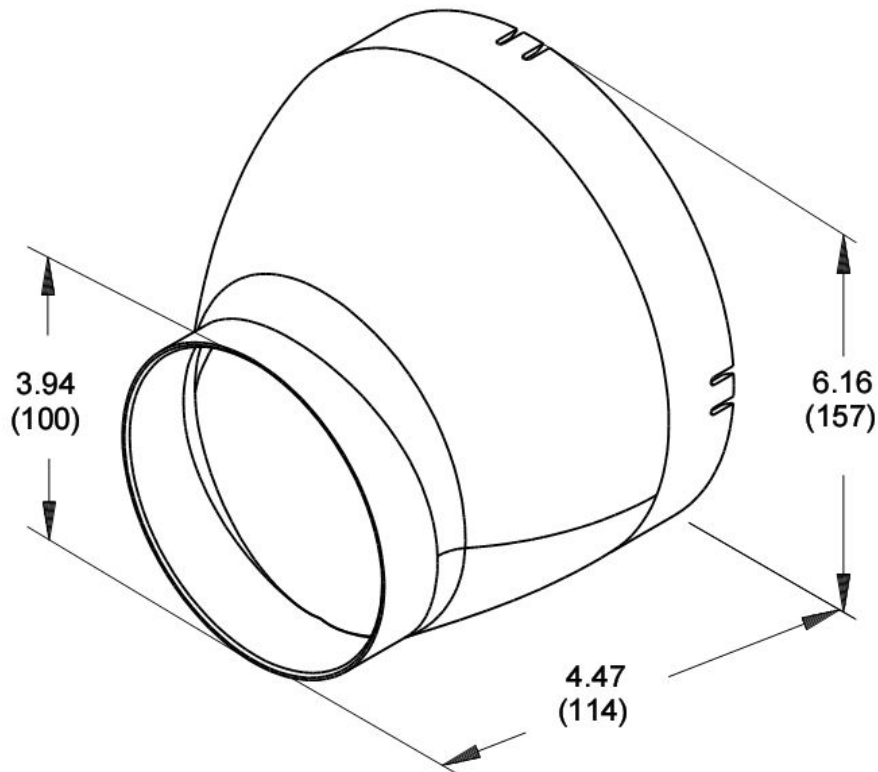

Notes: All dimensions shown are in units of in.

Performance	
Quantity	1
Volume (CFM)	900
Total External SP (in. wg)	1.041
Operating Power (hp)	0.43
Required Power (hp)	0.43
Fan RPM	2404
Max Fan RPM	3371
Elevation (ft)	256
Start-up Temp.(F)	70
Operating Temp.(F)	70

Model: FJC-308-BI
Centrifugal Utility Fume Exhaust Fan
Operating Performance

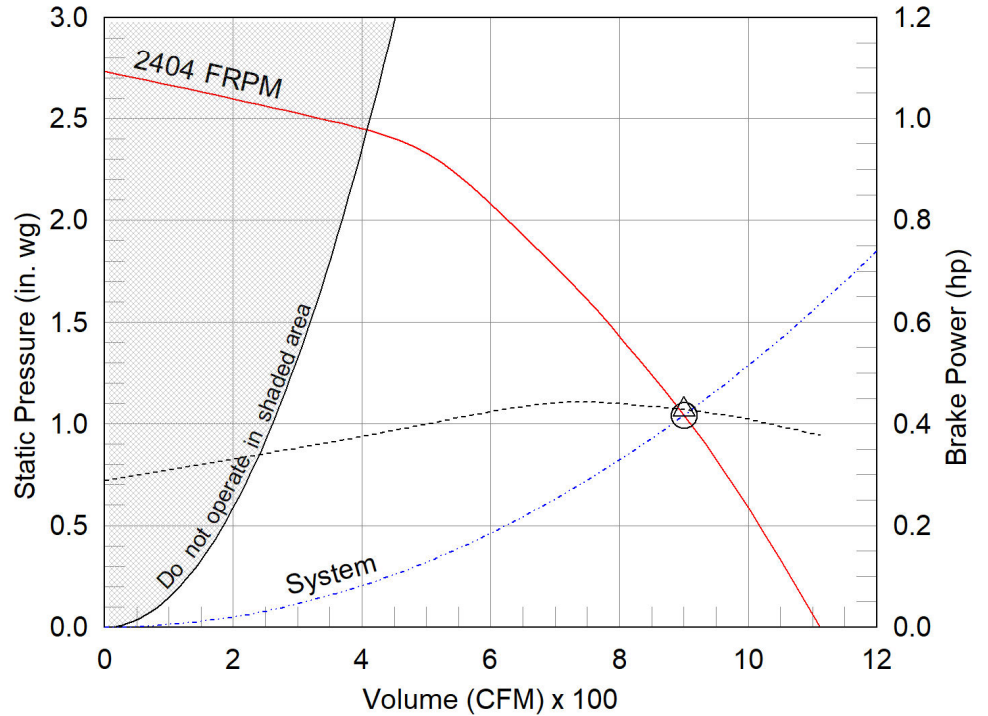

- △ Operating Bhp point
- Operating point at Total External SP
- Fan curve
- - - System curve
- - - Brake horsepower curve

Fan Configuration	
Size	8
Wheel Type	BI
Arrangement	10
Rotation	CW
Discharge Position	UB
Construction Type	PermaLock
Discharge Type	Fixed Nozzle
Spark Resistance	None
Scroll Material	Steel
Wheel Material	Aluminum
Inlet Cone Material	Steel

Equipment Weights	
Fan (LMD)(lb)	125
Motor/Drive (lb)	23
Accessories (lb)	103

Misc Fan Data	
Fan Energy Index (FEI)	-
Nozzle OV (ft/min)	1,510
Static Efficiency (%)	38
Tip Speed (ft/min)	6,607
Effective Plume Ht. (ft)	10.11
Calculation Method	Momentum Flux

Motor and Drives	
Motor	Included
Size (hp)	3/4
RPM	1725
Enclosure	ODP
V/C/P	460/60/3
Frame Size	56
Max Frame Size	145
Location	Centered
Pulley Type	Constant
Drive Loss (%)	9.1
Drives	Standard
Drive Service Factor	1.5
NEC FLA* (Amps)	1.6



Sound Power by Octave Band

Sound Data	62.5	125	250	500	1000	2000	4000	8000	LwA	dBA	Sones
Inlet	78	78	75	77	75	71	66	61	79	68	15.5

*FLA - based on tables 150 or 148 of National Electrical Code 2002. Actual motor FLA may vary, for sizing thermal overload, consult factory.

LwA - A weighted sound power level, based on ANSI S1.4

dBA - A weighted sound pressure level, based on 11.5 dB attenuation per octave band at 5 ft- dBA levels are not licensed by AMCA International

Sones - calculated using AMCA 301 at 5 ft

Model: FJC-308-BI

Centrifugal Utility Fume Exhaust Fan

Standard Construction Features:

HOUSING: Coated steel frame, scroll and stack - Bolted frame construction - Perma-Lock sealed scroll - Rectangular discharge stack - Adjustable motor plate - Corrosion resistant fasteners BEARINGS, SHAFT and WHEEL: Air handling quality, self-aligning, ball bearing in pillow block housing - L(10) 80,000 bearing life - Polished, solid steel shaft - Backward inclined centrifugal wheel

Selected Options & Accessories:

Motor with Class B or Greater Insulation
Standard Drives
Finish - Coated
Coated with Permatecor, Concrete Gray-RAL 7023, Fan and Attached Accessories
Switch - NEMA-3R, Toggle, For Indoor or Outdoor Use, Ship Separate
Discharge Position - UB
Wheel Type - BI
Bearings - L(10) Life of 80k Hours
UL/cUL-705 - Power Ventilators
Polished Steel Shaft
Curb Cap Inlet Box w/Access door, w/Damper, Permatecor, Duct Support
Access Door - Bolted
Damper, Gravity, 8.813 x 15.813, EM-10, Aluminum, Parallel, Mill Finish
Duct Drop, Sleeve Length - 12 inches, Permatecor coating
Drain Connection - 1" Drain Hole, Unthreaded
Inlet Connection - Slip Fit
Outlet Connection - Slip Fit
Weatherhood - Steel
Motor Starter
Unit Warranty: 1 Yr (Standard)

Model: FJC-308-BI

Centrifugal Utility Fume Exhaust Fan

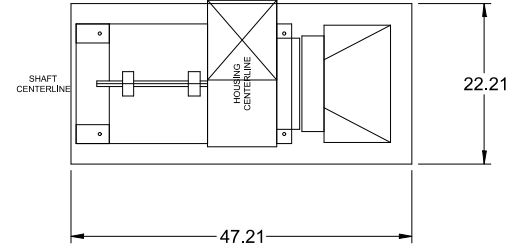

FAN FOOTPRINT

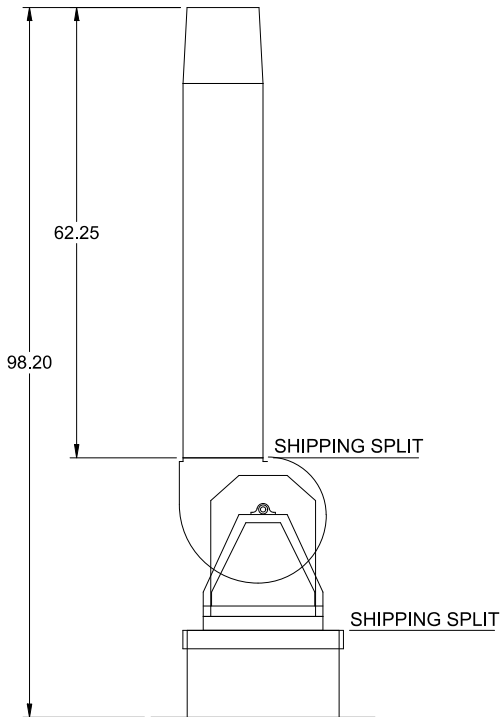

SIDE VIEW

*SIDE VIEW IS VIEWED FROM DRIVE SIDE

*FANS ARE SUBJECT TO ±.125 INCH TOLERANCE

*DUE TO CONTINUAL IMPROVEMENTS DIMENSIONS MAY CHANGE

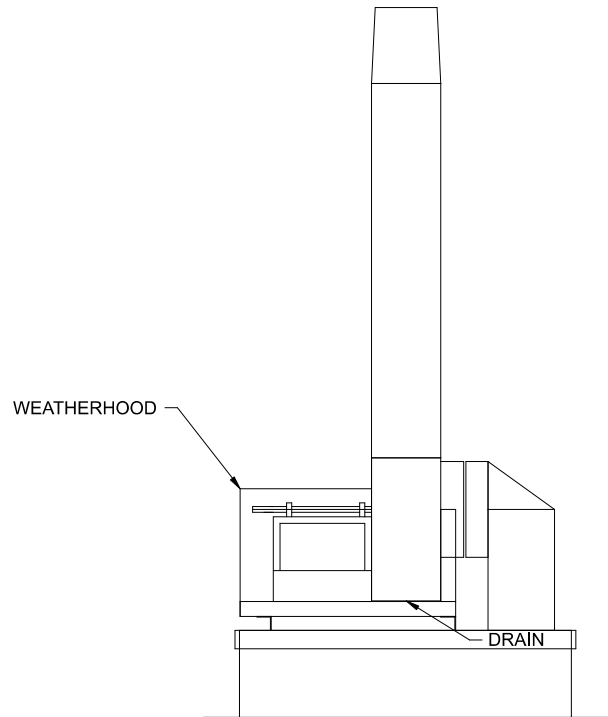

END VIEW

Notes: All dimensions shown are in units of in.

00

GREENHECK
Building Value in Air.

Printed Date: 07/26/2023
Job: Southside HS Addition Batesville
Mark: LEF-1
Model: FJC-308-BI

Inlet Connection

CURB CAP INLET BOX

The diagram illustrates the installation of a Curb Cap Inlet Box. The main view shows a rectangular box with an opening. Key dimensions include a total width of 47.21 inches, a duct opening width of 9.00 inches, and a duct opening height of 16.00 inches. The box is mounted on a roof curb, with a duct support structure (supplied by Greenheck) and a damper. A detailed cross-section view below shows the internal components: a damper, duct support, duct drop (16 x 9 x 12), roof curb, and the curb cap inlet box.

Notes: All dimensions shown are in units of in.

CAPS 4.41.1100

C:\Users\tracy.parker\OneDrive - Airetech Corporation\Jobs\Southside HS Addition Batesville.gfcj
Generated by: nick@airetechcorp.com

Page 4 of 28

Commercial Backdraft Damper

Model: EM-10

Standard Construction Features:

- Model EM-10 is a horizontal mount exhaust damper (air flow up) which is constructed of heavy gauge 0.125 in. extruded Aluminum. Damper blades are of heavy gauge 0.07 in. extruded aluminum with vinyl seals on the closing edge and counterbalance weights to assist opening. Metallic axles are 0.75 in., mounted in acetal bushings – Synthetic axle bearings. Maximum Velocity of 3,500 ft/min

Accessory Configuration

Damper Type:	Gravity
Damper Material:	Aluminum
Damper Blade Action:	Parallel
Damper Finish:	Mill Finish
Temperature:	180° F

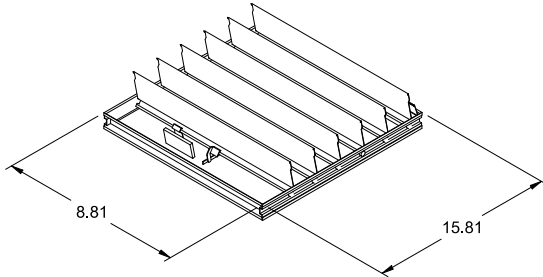

DAMPER

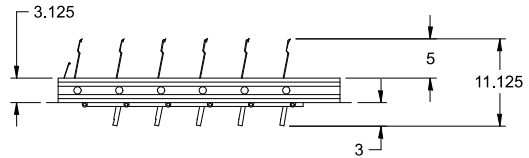

TYP. SECTION VIEW

Notes: All dimensions shown are in units of in.
Width and height furnished approximately 0.25 in. undersize

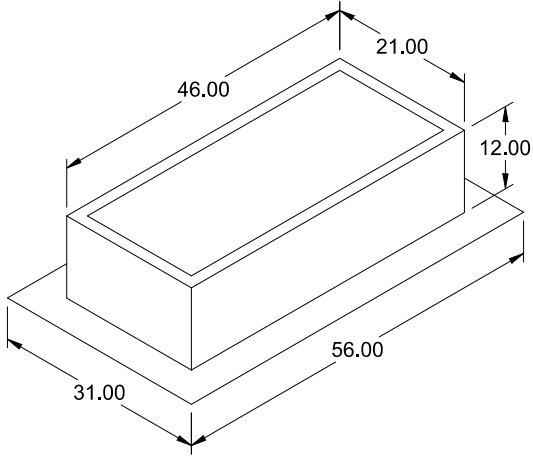

Model: GPFHL

Heavy Load Roof Curb

Standard Construction Features:

- Roof Curb fits between the building roof and the fan mounted directly to the roof support structure - Constructed of galvanized steel (14 ga) - Straight Sided - Single roof flashing flange (5 in. width) - Insulated (1 in. thick, 3 lb density).
NOTES: - Curb actual dimension is 0.5 in. smaller than cap dimension. - The maximum allowable roof opening dimension is actual minus 4 in.. - The Roof Opening Dimension may or may not be the same as the Structural Opening Dimension.

General

Tag	Qty	Model	Sizing Method	Undersizing (in.)	Weight (lb)	Shipped Assembled	Union Label
	1	GPFHL-22.2	Nominal	1.2	96	Yes	No Preference

Dimensions

Curb Height (in.)	Nominal Outside Width (in.)	Nominal Outside Length (in.)	Actual Outside Width (in.)	Actual Outside Length (in.)	Flange Width (in.)	Flange Length (in.)
12	22.2	47.2	21	46	50	31

*May not be applicable

Accessories

Material	Security Bars	Liner	Insulation (in.)	Insulation R Value
Galvanized	No	No	1	R4.3

Performance	
Quantity	1
Volume (CFM)	1,400
Total External SP (in. wg)	3.668
Operating Power (hp)	1.4
Required Power (hp)	1.4
Fan RPM	2680
Max Fan RPM	3274
Elevation (ft)	256
Start-up Temp.(F)	70
Operating Temp.(F)	70

Model: FJC-312-BI
Centrifugal Utility Fume Exhaust Fan
Operating Performance

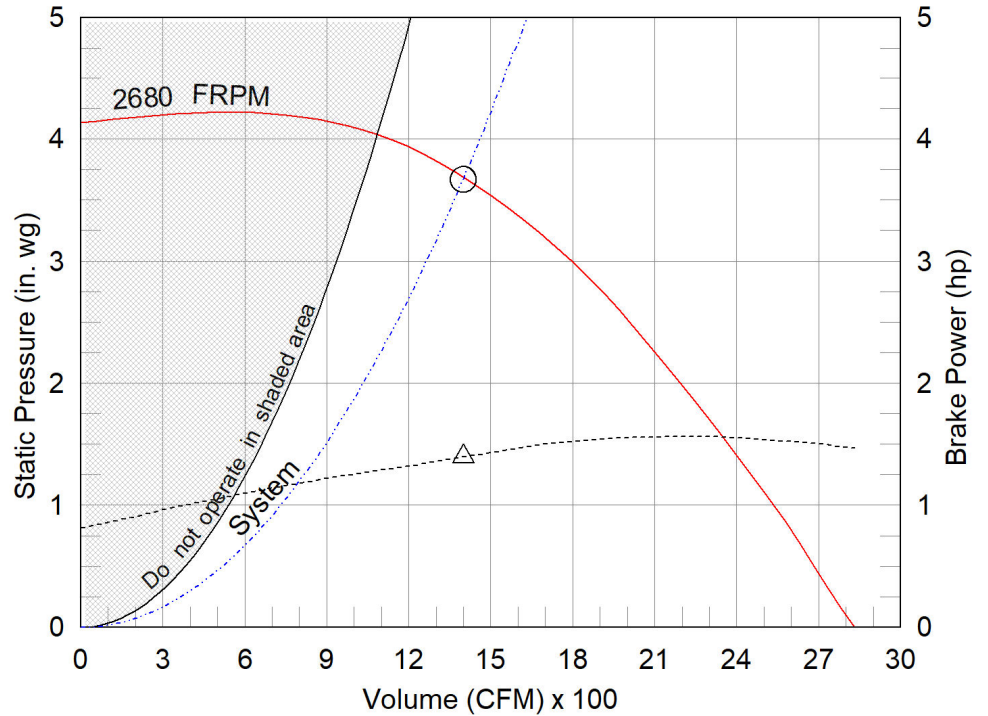

- △ Operating Bhp point
- Operating point at Total External SP
- Fan curve
- - - System curve
- - - Brake horsepower curve

Fan Configuration	
Size	12
Wheel Type	BI
Arrangement	10
Rotation	CW
Discharge Position	UB
Construction Type	PermaLock
Discharge Type	Fixed Nozzle
Spark Resistance	None
Scroll Material	Steel
Wheel Material	Steel
Inlet Cone Material	Steel

Equipment Weights	
Fan (LMD)(lb)	147
Motor/Drive (lb)	40
Accessories (lb)	125

Misc Fan Data	
Fan Energy Index (FEI)	0.17
Nozzle OV (ft/min)	2,003
Static Efficiency (%)	61
Tip Speed (ft/min)	8,596
Effective Plume Ht. (ft)	12.7
Calculation Method	Momentum Flux

Motor and Drives	
Motor	Included
Size (hp)	2
RPM	1725
Enclosure	ODP
V/C/P	460/60/3
Frame Size	145T
Max Frame Size	145
Location	Centered
Pulley Type	Constant
Drive Loss (%)	5.4
Drives	Standard
Drive Service Factor	1.5
NEC FLA* (Amps)	3.4



Sound Power by Octave Band

Sound Data	62.5	125	250	500	1000	2000	4000	8000	LwA	dBA	Sones
Inlet	85	85	81	84	81	77	76	73	86	75	24
Outlet	98	93	88	90	82	78	74	71	90	78	32

*FLA - based on tables 150 or 148 of National Electrical Code 2002. Actual motor FLA may vary, for sizing thermal overload, consult factory.

LwA - A weighted sound power level, based on ANSI S1.4

dBA - A weighted sound pressure level, based on 11.5 dB attenuation per octave band at 5 ft- dBA levels are not licensed by AMCA International

Sones - calculated using AMCA 301 at 5 ft

Model: FJC-312-BI

Centrifugal Utility Fume Exhaust Fan

Standard Construction Features:

HOUSING: Coated steel frame, scroll and stack - Bolted frame construction - Perma-Lock sealed scroll - Rectangular discharge stack - Adjustable motor plate - Corrosion resistant fasteners BEARINGS, SHAFT and WHEEL: Air handling quality, self-aligning, ball bearing in pillow block housing - L(10) 80,000 bearing life - Polished, solid steel shaft - Backward inclined centrifugal wheel

Selected Options & Accessories:

Motor VFD Rated
Motor with Shaft Grounding
Motor with Class B or Greater Insulation
Standard Drives
Finish - Coated
Coated with Permator, Concrete Gray-RAL 7023, Fan and Attached Accessories
Switch - NEMA-3R, Toggle, For Indoor or Outdoor Use, Ship Separate
Discharge Position - UB
Wheel Type - BI
Bearings - L(10) Life of 80k Hours
UL/cUL-705 - Power Ventilators
Polished Steel Shaft
Curb Cap Inlet Box w/Access door, w/Damper, Permator, Duct Support
Access Door - Bolted
Damper, Gravity, 9.813 x 18.813, EM-10, Aluminum, Parallel, Mill Finish
Duct Drop, Sleeve Length - 18 inches, Permator coating
Drain Connection - 1" Drain Hole, Unthreaded
Inlet Connection - Slip Fit
Outlet Connection - Slip Fit
Weatherhood - Steel
Unit Warranty: 1 Yr (Standard)

Model: FJC-312-BI

Centrifugal Utility Fume Exhaust Fan

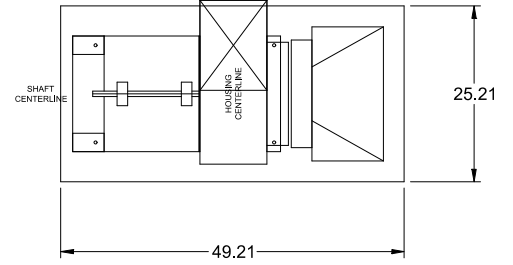

FAN FOOTPRINT

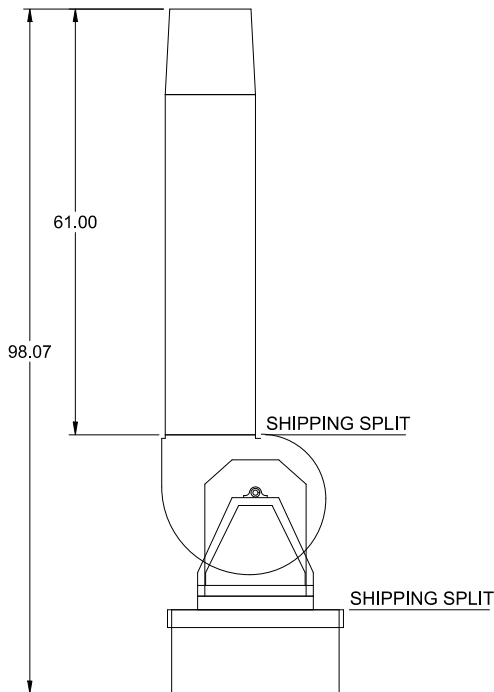

SIDE VIEW

*SIDE VIEW IS VIEWED FROM DRIVE SIDE

*FANS ARE SUBJECT TO ±.125 INCH TOLERANCE
*DUE TO CONTINUAL IMPROVEMENTS DIMENSIONS MAY CHANGE

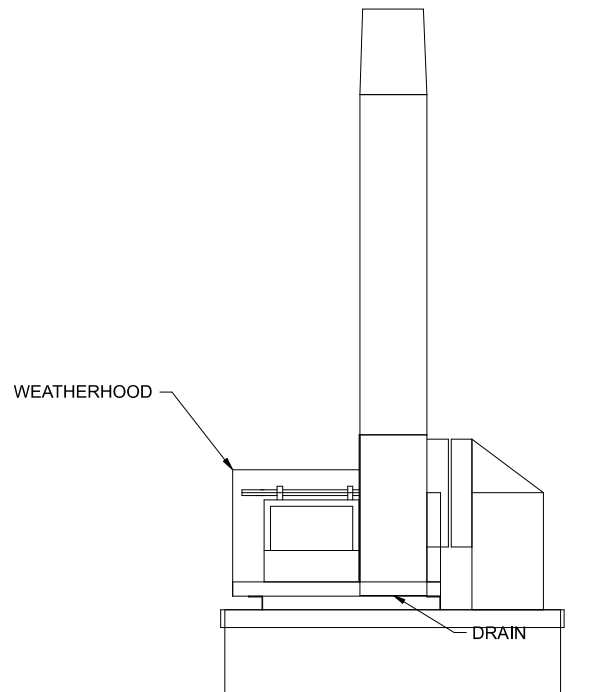

END VIEW

Notes: All dimensions shown are in units of in.

GREENHECK
Building Value in Air.

Printed Date: 07/26/2023
Job: Southside HS Addition Batesville
Mark: WEF-1
Model: FJC-312-BI

Inlet Connection

CURB CAP INLET BOX

DUCT SUPPORT
(SUPPLIED BY GREENHECK)
(MOUNTED TO ROOF CURB BY OTHERS)

INLET BOX OPENING

ROOF CURB

19.00

25.21

3.21

10.00

49.21

DAMPER

DUCT SUPPORT

CURB CAP INLET BOX

DUCT DROP (19 X 10 X 18)

ROOF CURB

Notes: All dimensions shown are in units of in.

CAPS 4.41.1100

C:\Users\tracy.parker\OneDrive - Airetech Corporation\Jobs\Southside HS Addition Batesville.gfcj
Generated by: nick@airetechcorp.com

Page 10 of 28

Commercial Backdraft Damper

Model: EM-10

Standard Construction Features:

- Model EM-10 is a horizontal mount exhaust damper (air flow up) which is constructed of heavy gauge 0.125 in. extruded Aluminum. Damper blades are of heavy gauge 0.07 in. extruded aluminum with vinyl seals on the closing edge and counterbalance weights to assist opening. Metallic axles are 0.75 in., mounted in acetal bushings – Synthetic axle bearings. Maximum Velocity of 3,500 ft/min

Accessory Configuration

Damper Type:	Gravity
Damper Material:	Aluminum
Damper Blade Action:	Parallel
Damper Finish:	Mill Finish
Temperature:	180° F

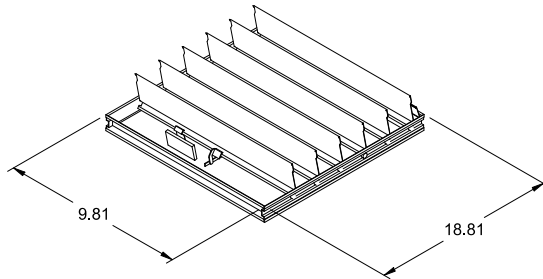

DAMPER

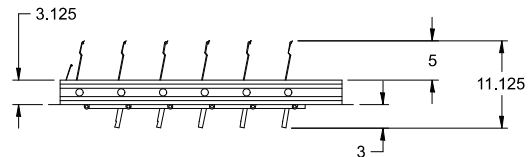

TYP. SECTION VIEW

Notes: All dimensions shown are in units of in.
Width and height furnished approximately 0.25 in. undersize

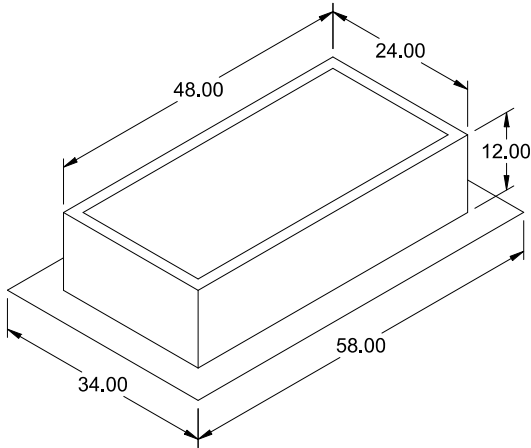

Model: GPFHL

Heavy Load Roof Curb

Standard Construction Features:

- Roof Curb fits between the building roof and the fan mounted directly to the roof support structure - Constructed of galvanized steel (14 ga) - Straight Sided - Single roof flashing flange (5 in. width) - Insulated (1 in. thick, 3 lb density).
NOTES: - Curb actual dimension is 0.5 in. smaller than cap dimension. - The maximum allowable roof opening dimension is actual minus 4 in.. - The Roof Opening Dimension may or may not be the same as the Structural Opening Dimension.

General

Tag	Qty	Model	Sizing Method	Undersizing (in.)	Weight (lb)	Shipped Assembled	Union Label
	1	GPFHL-25.2	Nominal	1.2	96	Yes	No Preference

Dimensions

Curb Height (in.)	Nominal Outside Width (in.)	Nominal Outside Length (in.)	Actual Outside Width (in.)	Actual Outside Length (in.)	Flange Width (in.)	Flange Length (in.)
12	25.2	49.2	24	48	52	34

*May not be applicable

Accessories

Material	Security Bars	Liner	Insulation (in.)	Insulation R Value
Galvanized	No	No	1	R4.3

Quotation Bill of Material

Item	Qty	Product Information
------	-----	---------------------

1	1	ACH580-VDR-03A5-4 <i>ACH580 6-Pulse drive package rated UL (NEMA) Type 1. Provided with Main Input Disconnect with VFD fuses and E-Clipse Bypass (Vertical). Rated for 3.5 amps (2 HP) at 480 VAC three phase.</i>
---	---	---

Equipment Tag: VFD-WEF-1

Terms:

- ***FOB ABB Factory***
- ***Proposal valid for 30 days from quotation date***
- ***ABB Inc. Standard Terms and Conditions of Sale apply***
- ***Proposal based upon acceptance of Clarifications and Exceptions to Specifications and Terms provide later in this quotation***

Submittal Schedule

This schedule includes the products supplied as part of this submittal.

Schedule			Motor Data ¹			Drive Data			
Item	Qty	Tag	HP	FLA	Volts	Product ID	HP	Amps	Volts
1	1	VFD-WEF-1	2	3.4	460 VAC	ACH580-VDR-03A5-4	2	3.5	480 VAC
<p>Notes:</p> <ol style="list-style-type: none"> AC motor data is per National Electrical Code Table 430.250 for typical motors used in most applications. It is provided as typical data only. DC motor data is per typical industry standards. Actual motor data may vary 									

Submittal Schedule Details for VFD-WEF-1

Item	Tag / Equipment ID	Product ID
1	VFD-WEF-1	ACH580-VDR-03A5-4

Item Description
<p>Input Voltage: 480 VAC Three Phase Rated Output Current: 3.5A Enclosure: UL (NEMA) Type 1 Nominal Horsepower: 2 HP Frame Size: R1 Input Disconnecting Means: Disconnect with VFD fuses Bypass: E-Clipse Bypass (Vertical) Input Impedance: 5% equivalent impedance Short Circuit Current Rating: 100 kA with fusing Communication Protocols: Johnson Controls N2, Modbus RTU, BACnet (MS/TP) Other Options:</p>

Drive Input Fuse Ratings	
Fuse Class	Amps (600 V)
Class CC	15

Wire Size Capacities of Power Terminals		
Input Wiring	Output Wiring	Ground Wiring
#14...#4 4.6 lbf-ft	#20...#6 1.2 lbf-ft	#14...#4 3 lbf-ft

Dimensions and Weights			
Height <i>in</i> (<i>mm</i>)	Width <i>in</i> (<i>mm</i>)	Depth <i>in</i> (<i>mm</i>)	Weight <i>lbs</i> (<i>kg</i>)
40.2 (1021)	5.4 (137)	10.6 (268)	30 (13.6)

Heat Dissipation & Airflow Requirements			
Power Losses		Airflow	
BTU/Hr	Watts	CFM	CM/Hr
297	87	25	42.5

Page Left Blank Intentionally

ACH580-01/-31

The ACH580 drive sets new standards in both simplicity and reliability, and ensures smooth, energy-efficient operation of your HVAC systems in normal and mission-critical situations.

ACH580-01, wall-mounted base drives

The ACH580-01 wall-mounted drives are available from 1 to 100 HP at 208/240 V, 1 to 350 HP at 480 V, and 2 to 250 HP at 575 V. The ACH580-01 drives are available in UL (NEMA) Type 1 and 12 configurations. In standard installations, the drive is mounted directly onto a wall and uses the provided conduit box. Conduit openings are provided for bottom conduit entry & exit. For mounting in a customer-supplied cabinet, the conduit box may be removed. The drive has a 100 kA SCCR rating when paired with appropriately sized upstream fuses.

ACH580-31, ultra low harmonic wall-mounted base drives

The ACH580-31 wall-mounted drives are available from 5 to 400 HP at 480 V. The ACH580-31 are available in UL (NEMA) Type 1 and 12 configurations. In standard installations, the drive is mounted directly onto a wall and uses the provided conduit box. Conduit openings are provided for bottom conduit entry and exit. For mounting in a customer-supplied cabinet, the conduit plate may be removed.

Features for HVAC

The ACH580 comes standard with an intuitive control panel used to configure, control, and monitor the drive. An optional Bluetooth control panel allows the drive to be configured via the control panel or the DriveTune app.

A robust HVAC firmware package provides drive, motor, and application protection features. Examples of drive protection features include undervoltage, overvoltage, overcurrent, and ground fault protection. The ACH580 also has a variety of motor protection features including overload and stall protections.

Application specific features, such as accepting four separate start interlocks (safeties), along with broken belt detection, are also included. The drive includes BACnet MS/TP, Modbus RTU, and Johnson N2 as standard. Additional protocols, such as BACnet/IP and LonWorks, are available with optional fieldbus adapters.

Technical specifications

Product compliance (complete list on following page)

ACH580-01/-31 CE, UL, cUL, and EAC

Supply connection

Input voltage (U_1)	
ACH580-xx-xxxA-2	208/240V
ACH580-xx-xxxA-4	480V
ACH580-xx-xxxA-6	600V
Input voltage tolerance	+10% / -15%
Phase	3-phase (1-phase, 240 V)
Frequency	48 to 63 Hz
Line Limitations	Max $\pm 3\%$ of nominal phase to phase input voltage
Power Factor ($\cos \varphi$) at nominal load	
ACH580-01	0.98
ACH580-31	1.0
Efficiency at rated power	
ACH580-01	98.0%
ACH580-31	96.5%
Power Loss	Approximately 2% of rated power

Motor connection

Supported motor control	Scalar and vector
Supported motor types	Asynchronous motor, permanent magnet motor (vector), SynRM (vector)
Voltage	3-phase, from 0 to supply voltage
Frequency	0 to 500 Hz
Short Term Overload Capacity Variable Torque	110% for 1 min/10min
Peak Overload Capacity Variable Torque	1.35 for 2 second (2 sec / 10 min)
Switching Frequency	2, 4, 8 or 12 kHz Automatic fold back in case of overload
Acceleration/Deceleration Time	0 to 1800 s
Short Circuit Current Rating (SCCR)	100 ka with fusing

Inputs and outputs (drive)

2 analog inputs	Selection of Current/Voltage input mode is user programmable.
Voltage reference	0 (2) to 10 V, $R_{in} > 200 \text{ k}\Omega$
Current reference	0 (4) to 20 mA, $R_{in} = 100 \Omega$
Potentiometer reference value	10 V $\pm 1\%$ max. 20 mA
2 analog outputs	AO1 is user programmable for current or voltage. AO2 current
Voltage reference	0 to 10 V, $R_{load} > 100 \text{ k}\Omega$
Current reference	0 to 20 mA, $R_{load} < 500 \Omega$
Applicable potentiometer	1 k Ω to 10 k Ω
Internal auxiliary voltage	24 V DC $\pm 10\%$, max. 250 mA
Accuracy	+/- 1% full scale range at 25°C (77°F)
Output updating time	2 ms
6 digital inputs	12 to 24 V DC, 10 to 24 V AC, Connectivity of PTC sensors supported by a single digital input.

	PNP or NPN connection (5 DIs with NPN connection). Programmable
Input Updating Time	2 ms
3 relay outputs	Maximum switching voltage 250 V AC/30 V DC. Maximum continuous current 2 A rms. Programmable, Form C
Adjustable filters on analog inputs and outputs	
All control inputs isolated from ground and power	
Operation	
Air temperature	0 to -15 °C (32 to 5 °F). -15 to +50 °C (5 to 122 °F): No frost allowed. Output derated above +40 °C (104 °F)
Installation site altitude	0 to 4000 m (13123 ft) above sea level Output derated above 1000 m (3281 ft)
Relative humidity	5 to 95% No condensation allowed Maximum relative humidity is 60% in the presence of corrosive gasses
Atmospheric pressure	70 to 106 kPa (10.2 to 15.4 PSI) 0.7 to 1.05 atmospheres
Vibration	Risk category IV Certified (IBC 2018)
Environmental protections	
Chemical Gasses	Class 3C2
Solid Particles	Class 3S2 No conductive dust allowed
Pollution degree (IEC/EN 61800-5-1)	Pollution degree 2
Product compliance	
Standards and directives	Low Voltage Directive 2006/95/EC EMC Directive 2004/108/EC 60721-3-3: 2002 60721-3-1:1997 Quality assurance system ISO 9001 and Environmental system ISO 14001 CE, UL, cUL, and EAC approvals Galvanic isolation according to PELV RoHS2 (Restriction of Hazardous Substances) EN 61800-5-1: 2007; IEC/EN 61000-3-12; EN61800-3: 2017 + A1: 2012 Category C2 (1st environment restricted distribution); Safe torque off (EN 61800-5-2) BACnet Testing Laboratory (BTL) Seismic (IBC, OSHPD) Plenum (ACH580-01 only)
EMC (according to EN61800-3)	ACH580-01 and ACH580-31 class C2 (1st environment restricted distribution)

Storage (in Protective Shipping Package)

Air Temperature	-40 to +70 °C (-40 to +158 °F)
Relative Humidity	Less than 95% No condensation allowed Maximum relative humidity is 60% in the presence of corrosive gasses
Chemical Gasses	Class 1C2
Solid Particles	Class 1S2 Contact ABB regarding Class 1S3
Atmospheric pressure	70 to 106 kPa 0.7 to 1.05 atmospheres
Vibration (ISTA)	
R1...R4	In accordance with ISTA 1A
R5...R9	In accordance with ISTA 3E

Transportation (in Protective Shipping Package)

Air Temperature	-40° to 70°C (-40° to 158°F)
Relative Humidity	Less than 95% No condensation allowed Maximum relative humidity is 60% in the presence of corrosive gasses
Atmospheric Pressure	60 to 106 kPa (8.7 to 15.4 PSI) 0.6 to 1.05 atmospheres
Free Fall	R1: 76 cm (30 in) R2: 61 cm (24 in) R3: 46 cm (18 in) R4: 31 cm (12 in) R5: 25 cm (10 in)
Chemical Gasses	Class 2C2
Solid Particles	Class 2S2
Shock/ Drop (ISTA)	
R1...R4	In accordance with ISTA 1A
R5...R9	In accordance with ISTA 3E
Vibration (ISTA)	
R1...R4	In accordance with ISTA 1A
R5...R9	In accordance with ISTA 3E

Feature overview

Communication

Protocols as standard (EIA-485): BACnet MS/TP, Modbus RTU, Johnson Controls N2

Available as plug-in options: BACnet/IP, Modbus TCP, PROFIBUS-DP, DeviceNet, EtherNet/IP, LonWorks (coming 2019)

Application functions

Start interlock

Delayed start

Run permissive (damper monitoring)

Override operation mode

Real-time clock (scheduling)

PID controllers for motor and process

Motor flying start

Motor preheating

Energy optimizer and calculators

Timer

2 or 3 wire start/stop

Ramp to stop

2 independent adjustable accel/decel ramp

Protection functions

Overvoltage controller

Undervoltage controller

Motor earth-leakage monitoring

Motor short-circuit protection

Motor overtemperature protection

Output and input switch supervision

Motor overload protection (UL508C)

Phase-loss detection (both motor and supply)

Under load supervision (belt loss detection)

Overload supervision

Stall protection

Loss of reference

Panel loss

Ground fault

External events

Overcurrent

Current limit regulator

Transient/Surge protection (MOV and choke)

Panel functions

First start assistant

Primary settings for HVAC applications

Hand-Off-Auto operation mode

HVAC quick set-up

Includes Day, Date and Time

Operator Panel Parameter Backup (read/write)

Full Graphic and Multilingual Display for Operator Control,

Parameter Set-Up and Operating Data Display:

- Output Frequency (Hz)
- Speed (RPM)
- Motor Current
- Calculated % Motor Torque
- Calculated Motor Power (kW)
- DC Bus Voltage
- Output Voltage
- Heatsink Temperature
- Elapsed Time Meter (resettable)

- kWh (resettable)
- Input / Output Terminal Monitor
- PID Actual Value (Feedback) & Error Fault Text
- Warning Text
- Three (3) Scalable Process Variable Displays
- User-Definable Engineering Units

Motor control features

Scalar (V/Hz) and vector modes of motor control

V/Hz shapes

- Linear
- Squared

Energy optimization

IR compensation

Slip compensation

Three (3) Critical Frequency Lockout Bands

PID control

One (1) Process PID

Four (4) Integral Independent Programmable PID

Setpoint Controllers (Process and External)

External Selection between Two (2) Sets of Process

PID Controller Parameters

PID Sleep/Wake-Up

Control panel features

The ACH580 Assistant Control Panel features:

- Intuitive to operate
- Primary Setting menu to ease drive commissioning
- Real-time clock
- Diagnostic and maintenance functions
- Full-graphic display, including chart, graph, and meter options
- 21 editable home views
- USB interface for PC and tool connection as standard
- Parameters are alpha-numeric
- North American version supports 14 languages as standard
- Dedicated "Help" key
- 4 user sets
- Parameters are stored in control panel memory for later transfer to other drives or for backup of a particular system
- Back-up and restore parameters and/or motor data
- Automatic back-up 2 hours after parameter change
- Modified parameter display
- Creates unique short menu
- Shows parameters that differ from the default
- Bluetooth connectivity for use with mobile device (requires +J429 option)

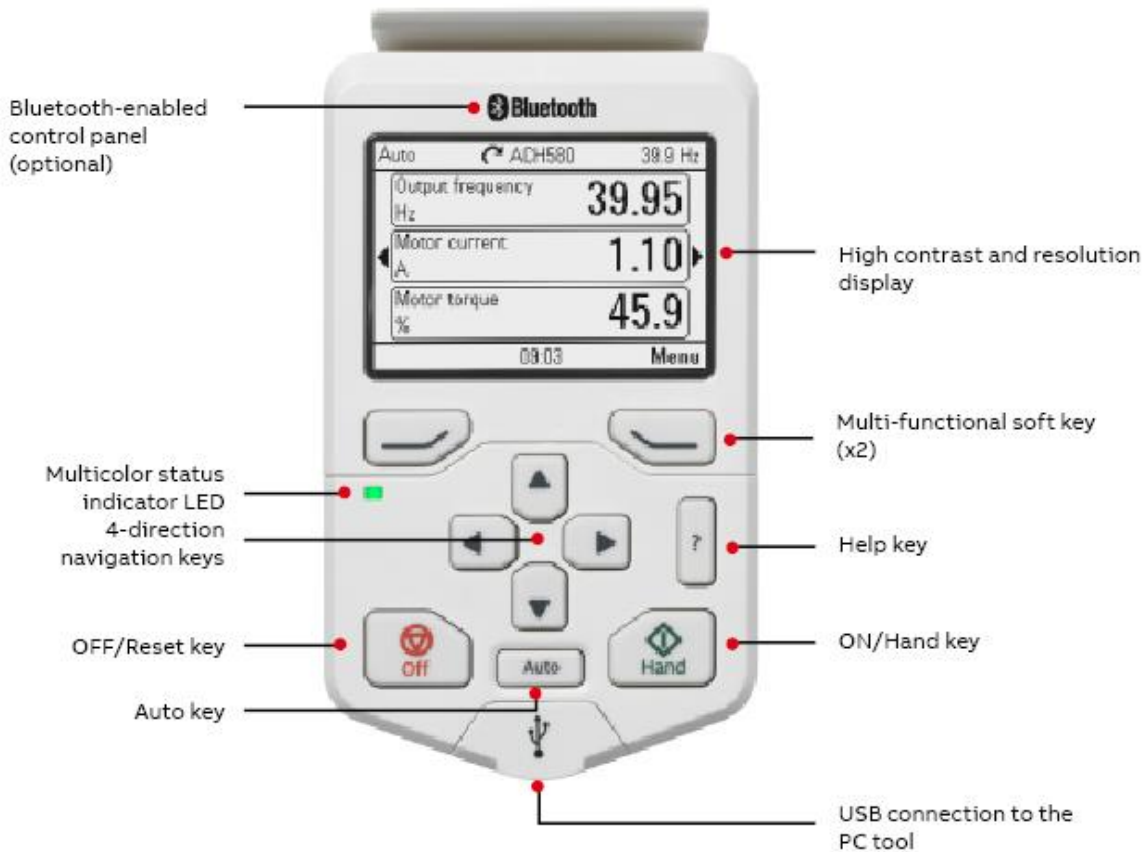

Cable connections

The following illustrations show the ACH580-01 and ACH580-31 cable connection points for the base drive. The illustrations indicate the location of input and output power connections as well as equipment and motor grounding connection points.

ACH580 drives are configured for wiring access from the bottom only. At least three separate metallic conduits are required, one for input power, one for output power to the motor and one for control signals.

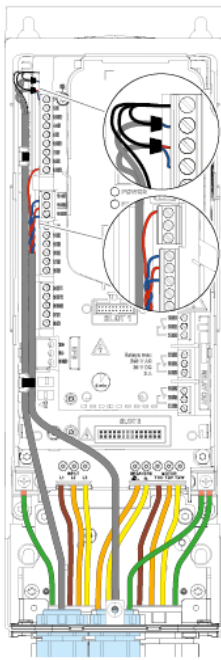

ACH580-01, R1-R2, UL (NEMA) Type 1 and 12

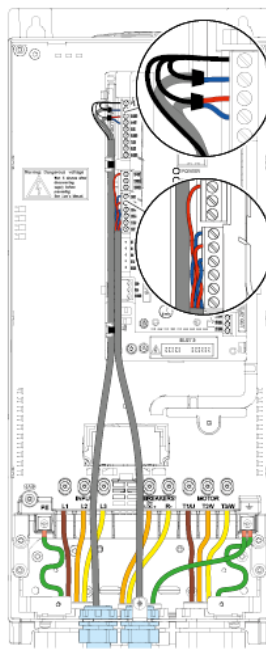

ACH580-01, R3, UL (NEMA) Type 1 and 12

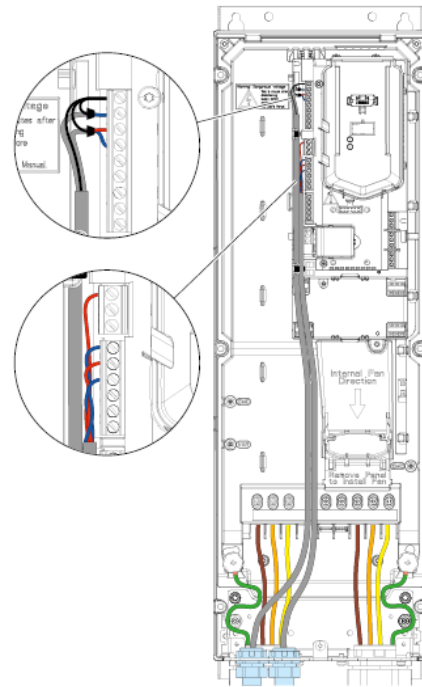

ACH580-01, R4, UL (NEMA) Type 1 and 12

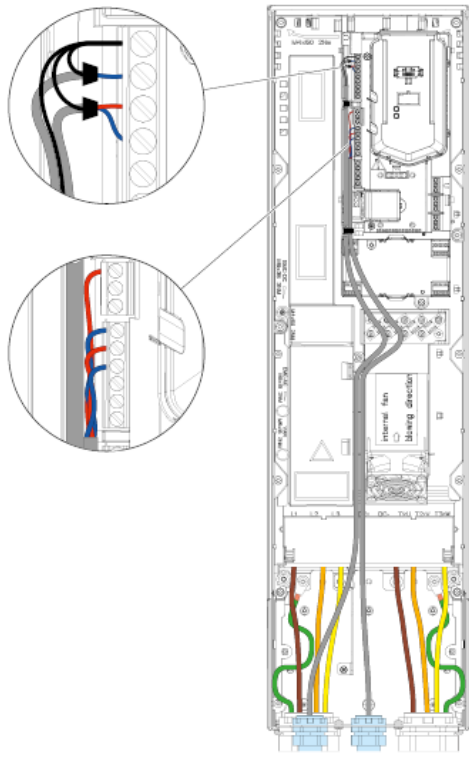

ACH580-01, R5, UL (NEMA) Type 1 and 12

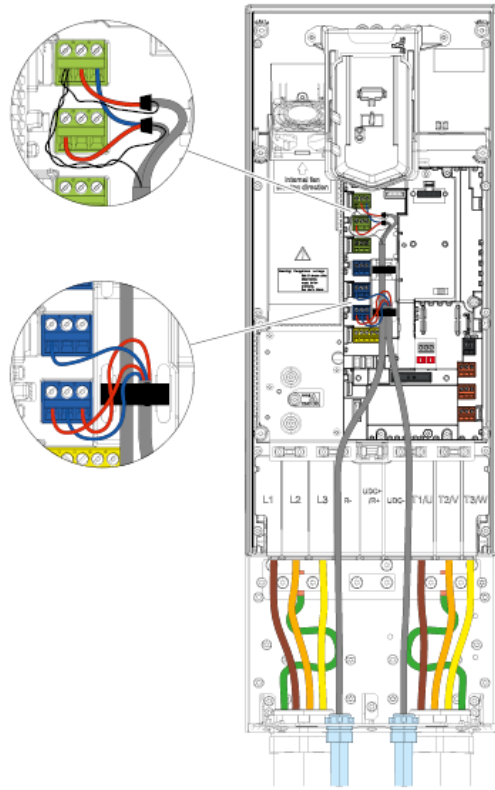

ACH580-01, R6-9, UL (NEMA) Type 1 and 12

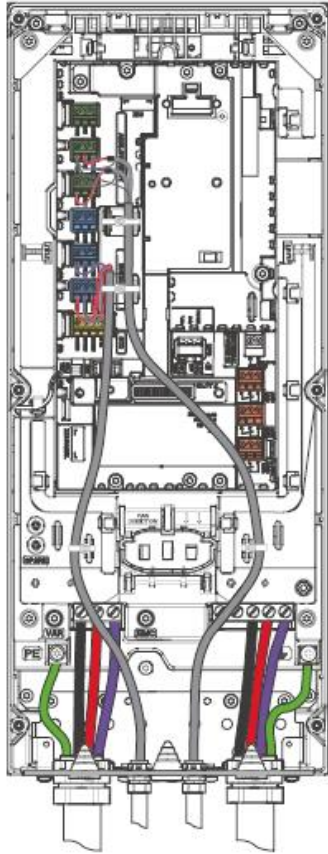

ACH580-31, R3, UL (NEMA) Type 1 and 12

Control connections

Default control connections

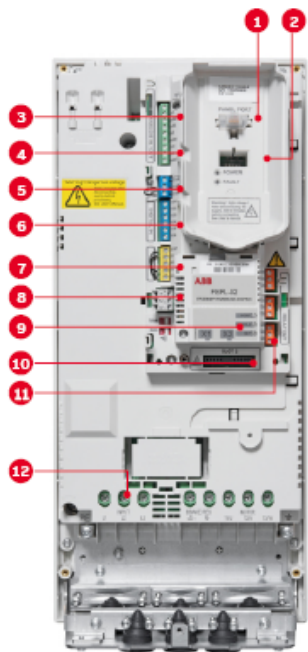

1. Panel port (PC tools, control panel)
2. ABB drive customizer port for programming the drive without mains
3. Analog inputs (2 × AI)
4. Analog outputs (2 × AO)
5. 24 V DC output
6. Digital inputs (6 × DI)
7. Safe torque off (STO)
8. Embedded fieldbus
9. Communication options (fieldbuses)
10. Analog and digital I/O extensions
11. Relay outputs (3 × RO)
12. Mains connection

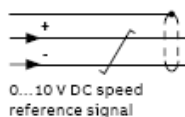

Terminal	Meaning	Default macro connections	
X1 Reference voltage and analog inputs and outputs			
1	SCR	Signal cable shield (screen)	
2	AI1	Output frequency/speed reference: 0 to 10 V	
3	AGND	Analog input circuit common	
4	+10 V	Reference voltage 10 V DC	
5	AI2	Actual feedback: 0 to 20 mA	
6	AGND	Analog input circuit common	
7	AO1	Output frequency: 0 to 10 V	
8	AO2	Motor current: 0 to 20 mA	
9	AGND	Analog output circuit common	
X2 & X3 Aux. voltage output and programmable digital inputs			
10	+24 V	Aux. voltage output +24 V DC, max. 250 mA	
11	DGND	Aux. voltage output common	
12	DCOM	Digital input common for all	
13	DI1	Stop (0)/Start (1)	
14	DI2	Not configured	
15	DI3	Constant frequency/speed selection	
16	DI4	Start interlock 1 (1 = allow start)	
17	DI5	Not configured	
18	DI6	Not configured	
X6, X7, X8 Relay outputs			
19	RO1C	Damper control 250 V AC/30 V DC 2 A	Energize damper 19 connected to 21
20	RO1A		
21	RO1B		
22	RO2C	Running 250 V AC/30 V DC 2 A	Running 22 connected to 24
23	RO2A		
24	RO2B		
25	RO3C	Fault (-1) 250 V AC/30 V DC 2 A	Fault condition 25 connected to 26
26	RO3A		
27	RO3B		
X5 Embedded fieldbus			
29	B+		
30	A-	Embedded fieldbus, EFB (EIA-485)	
31	DGND		
54	TERM	Termination switch	
55	BIAS	Bias resistors switch	
X4 Safe torque off			
34	OUT1	Safe torque off. Factory connection. Both circuits must be closed for the drive to start. See chapter <i>The Safe torque off function</i> in the <i>hardware manual</i> of the drive.	
35	OUT2		
36	SGND		
37	IN1		
38	IN2		
X10 24 V AC/DC			
40	24 V AC/DC+ in	R6-R11 only: Ext. 24 V AC/DC input to power up the control unit when the main supply is disconnected.	
41	24 V AC/DC- in		

Notes:

- Connected with jumpers at the factory.
- Only frames R6-R11 have terminals 40 and 41 for external 24 V AC/DC input.

PRODUCT OVERVIEW

ACH580 E-Clipse Bypass

The ACH580 drive sets new standards in both simplicity and reliability, and ensures smooth, energy-efficient operation of your HVAC systems in normal and mission-critical situations.

The ACH580 with ABB E-Clipse bypass is an ACH580 HVAC Drive in an integrated UL (NEMA) Type 1, 12 or 3R enclosure with a bypass motor starter. The ACH580 with ABB E-Clipse bypass provides an input disconnect switch or circuit breaker with door mounted and interlocked operator (padlockable in the OFF position), a bypass starter, electronic motor overload protection, a door mounted control panel with graphical display for local control, provisions for external control connections, and serial communications capability. Configurations with the +F267 option include a drive service switch.

UL (NEMA) Type 1 and 12 E-Clipse units are available from 1 to 100 HP at 208/230V, 1 to 350 HP at 460V, and 2 to 150 HP at 575V. UL (NEMA) Type 1 and 12 units are wall mounted from 1 to 200 HP.

For outdoor applications, UL (NEMA) Type 3R E-Clipse unit are available from 1 to 100 HP at 208/230V, 1 to 350 HP at 460V and 2 to 150 HP at 575V. Construction is sheet steel with a tough powder coat paint finish for corrosion resistance. A thermostatically controlled space heater and forced ventilated air cooling system are standard.

The ACH580 with ABB E-Clipse bypass includes two contactors. One contactor is the bypass contactor, used to connect the motor directly to the incoming power line in the event that the ACH580 is out of service. The other contactor is the ACH580 output contactor that disconnects the ACH580 from the motor when the motor is operating in the Bypass mode. The drive output contactor and the bypass contactor are electrically interlocked to prevent “back feeding”.

The ACH580 with ABB E-Clipse bypass is a microprocessor-controlled “intelligent” system which features programmable Class 10, 20, or 30 overload curves, programmable underload (broken belt) and overload trip or indication. Also included as standard features are single-phase protection in bypass mode, programmable manual or automatic transfer to bypass, fireman’s override, smoke control, damper control, no contactor chatter on brown-out power conditions and serial communications. Should a drive problem occur, fast acting fuses exclusive to the ACH580 drive path disconnect the drive from the line prior to clearing upstream branch circuit protection, maintaining bypass capability.

Technical specifications

Product compliance (complete list on following page)

ACH580-VxR/BxR UL508A

Supply connection

Input voltage (U ₁)	
ACH580-xx-xxxA-2	208/240V
ACH580-xx-xxxA-4	480V
ACH580-xx-xxxA-6	600V
Input voltage tolerance	+10% / -15%
Phase	3-phase
Frequency	48 to 63 Hz
Line Limitations	Max ±3% of nominal phase to phase input voltage
Power Factor (cos φ) at nominal load	
ACH580-VxR	0.98
ACH580-BxR	0.98
Efficiency at rated power	
ACH580-VxR	98.0%
ACH580-BxR	98.0%
Power Loss	Approximately 2% of rated power

Motor connection

Supported motor control	Scalar and vector
Supported motor types	Asynchronous motor
Voltage	3-phase, from 0 to supply voltage
Frequency	0 to 500 Hz
Short Term Overload Capacity Variable Torque	110% for 1 min/10min
Peak Overload Capacity Variable Torque	1.35 for 2 second (2 sec / 10 min)
Switching Frequency	2, 4, 8 or 12 kHz Automatic fold back in case of overload
Acceleration/Deceleration Time	0 to 1800 s
Short Circuit Current Rating (SCCR)	

	240V	480V	600V
-VCR	100kA	100kA	10 kA
-VDR*	100kA	100kA	100 kA
-BCR	100kA	100kA	10 kA
-BDR*	100kA	100kA	100 kA

* External fuses are required for 100 kA rating as specified in the "Technical Data" section of User Manual [3AXD50000289554](#).

Technical specifications

Inputs and outputs (drive)	
2 analog inputs	Selection of Current/Voltage input mode is user programmable.
Voltage reference	0 (2) to 10 V, $R_{in} > 200 \text{ k}\Omega$
Current reference	0 (4) to 20 mA, $R_{in} = 100 \Omega$
Potentiometer reference value	10 V $\pm 1\%$ max. 20 mA
2 analog outputs	AO1 is user programmable for current or voltage. AO2 current
Voltage reference	0 to 10 V, $R_{load} > 100 \text{ k}\Omega$
Current reference	0 to 20 mA, $R_{load} < 500 \Omega$
Applicable potentiometer	1 k Ω to 10 k Ω
Internal auxiliary voltage	24 V DC $\pm 10\%$, max. 250 mA
Accuracy	+/- 1% full scale range at 25°C (77°F)
Output updating time	2 ms
6 digital inputs	12 to 24 V DC, 10 to 24 V AC, Connectivity of PTC sensors supported by a single digital input. PNP or NPN connection (5 DIs with NPN connection). Programmable
Input Updating Time	2 ms
3 relay outputs	Maximum switching voltage 250 V AC/30 V DC. Maximum continuous current 2 A rms. Programmable, Form C
Contact material	Silver Tin Oxide (AgSnO ₂)
PTC, PT100 and PT1000	Any of the analog inputs, or digital input 6, are configurable for PTC with up to 6 sensors.
Adjustable filters on analog inputs and outputs	
All control inputs isolated from ground and power	
Operation	
Air temperature	0 to -15 °C (32 to 5 °F). -15 to +50 °C (5 to 122 °F): No frost allowed. Output derated above +40 °C (104 °F)
Installation site altitude	0 to 1000 m (3281 ft) above sea level Output derated above 1000 m (3281 ft)
Relative humidity	5 to 95% No condensation allowed Maximum relative humidity is 60% in the presence of corrosive gasses
Atmospheric pressure	70 to 106 kPa (10.2 to 15.4 PSI) 0.7 to 1.05 atmospheres
Siesmic	Risk category IV Certified (IBC 2018)

Feature overview

Communication

Protocols as standard (EIA-485): BACnet MS/TP, Modbus RTU, Johnson Controls N2
Available as plug-in options: BACnet/IP, Modbus TCP, PROFIBUS-DP, DeviceNet, EtherNet/IP

Application functions

Start interlock
Delayed start
Run permissive (damper monitoring)
Override operation mode
Real-time clock (scheduling)
PID controllers for motor and process
Motor flying start
Motor preheating
Energy optimizer and calculators
Timer
2 or 3 wire start/stop
Ramp to stop
2 independent adjustable accel/decel ramp

Protection functions

Overvoltage controller
Undervoltage controller
Motor earth-leakage monitoring
Motor short-circuit protection
Motor overtemperature protection
Output and input switch supervision
Motor overload protection (UL508C)
Phase-loss detection (both motor and supply)
Under load supervision (belt loss detection)
Overload supervision
Stall protection
Loss of reference
Panel loss
Ground fault
External events
Overcurrent
Current limit regulator
Transient/Surge protection (MOV and choke)

Panel functions

First start assistant
Primary settings for HVAC applications
Hand-Off-Auto operation mode
HVAC quick set-up
Includes Day, Date and Time
Operator Panel Parameter Backup (read/write)
Full Graphic and Multilingual Display for Operator Control,
Parameter Set-Up and Operating Data Display:

- Output Frequency (Hz)
- Speed (RPM)
- Motor Current
- Calculated % Motor Torque
- Calculated Motor Power (kW)

- DC Bus Voltage
- Output Voltage
- Heatsink Temperature
- Elapsed Time Meter (resettable)
- kWh (resettable)
- Input / Output Terminal Monitor
- PID Actual Value (Feedback) & Error Fault Text
- Warning Text
- Three (3) Scalable Process Variable Displays
- User-Definable Engineering Units

Motor control features

Scalar (V/Hz) and vector modes of motor control
V/Hz shapes

- Linear
- Squared

Energy optimization
IR compensation
Slip compensation
Three (3) Critical Frequency Lockout Bands

PID control

One (1) Process PID
Four (4) Integral Independent Programmable PID Setpoint Controllers (Process and External)
External Selection between Two (2) Sets of Process PID Controller Parameters
PID Sleep/Wake-Up

Control panel features

The ACH580 Assistant Control Panel features:

- Intuitive to operate
- Primary Setting menu to ease drive commissioning
- Real-time clock
- Diagnostic and maintenance functions
- Full-graphic display, including chart, graph, and meter options
- 21 editable home views
- USB interface for PC and tool connection as standard
- Parameters are alpha-numeric
- North American version supports 14 languages as standard
- Dedicated "Help" key
- 4 user sets
- Parameters are stored in control panel memory for later transfer to other drives or for backup of a particular system
- Back-up and restore parameters and/or motor data
- Automatic back-up 2 hours after parameter change
- Modified parameter display
- Creates unique short menu
- Shows parameters that differ from the default
- Bluetooth connectivity for use with mobile device (requires +J429 option)

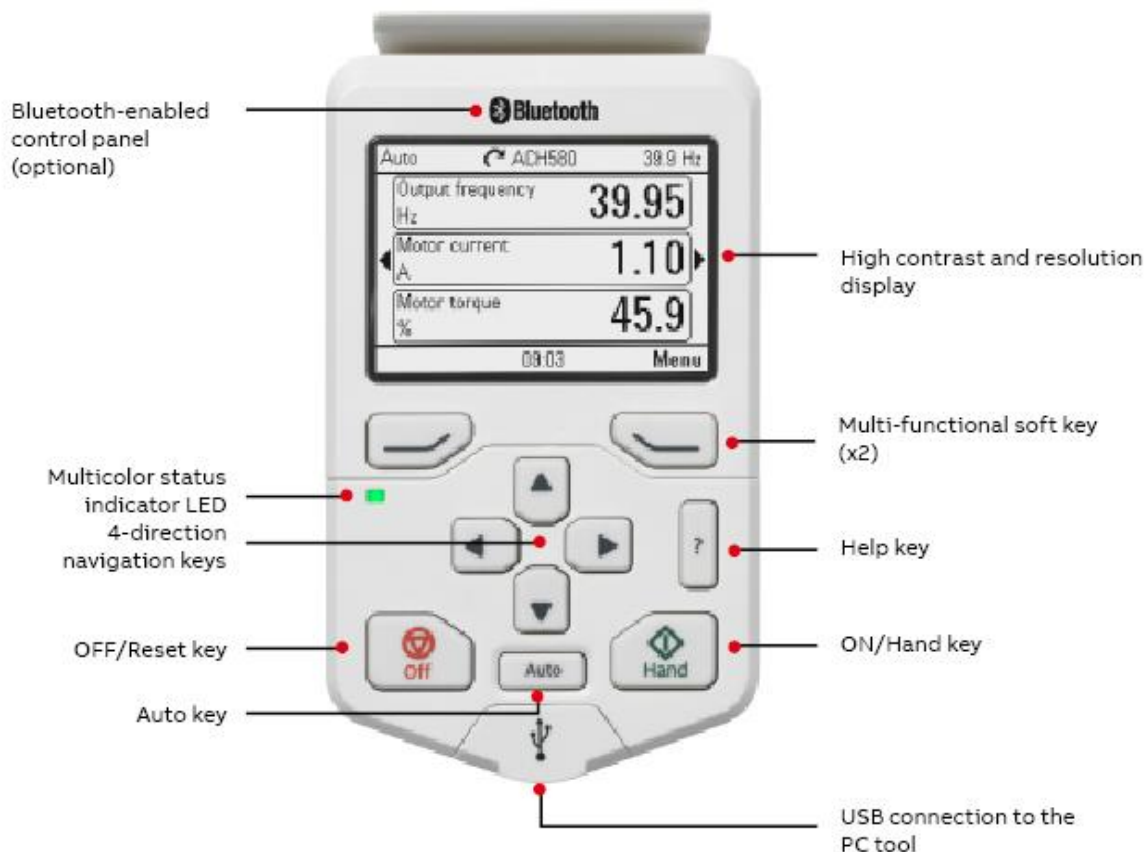

E-Clipse control panel features

The ACH580 E-Clipse Control Panel features:

- Dedicated programming and operating controls (keys) are logically grouped on the keypad by their function.
 - o H-O-A, Drive/Bypass Selection keys (Control)
 - o UP/DOWN arrows, ESC, ENTER keys (Programming)
- LCD display provide:
 - o Operating Control Status
 - o Bypass Status
 - o Fault/Warning annunciation
 - o Parameter Lists and Values
 - o Power On indication
- Individual LEDs arranged to provide a logical control path visual:
 - o System Enabled
 - o Separate multi colored Drive and Bypass "SELECTED/FAULTED LEDs in separate paths
 - o Motor Run Indicator
 - o LEDs that illuminate, change color, and flash to provide visible indication of system status
- Provides System control from one location

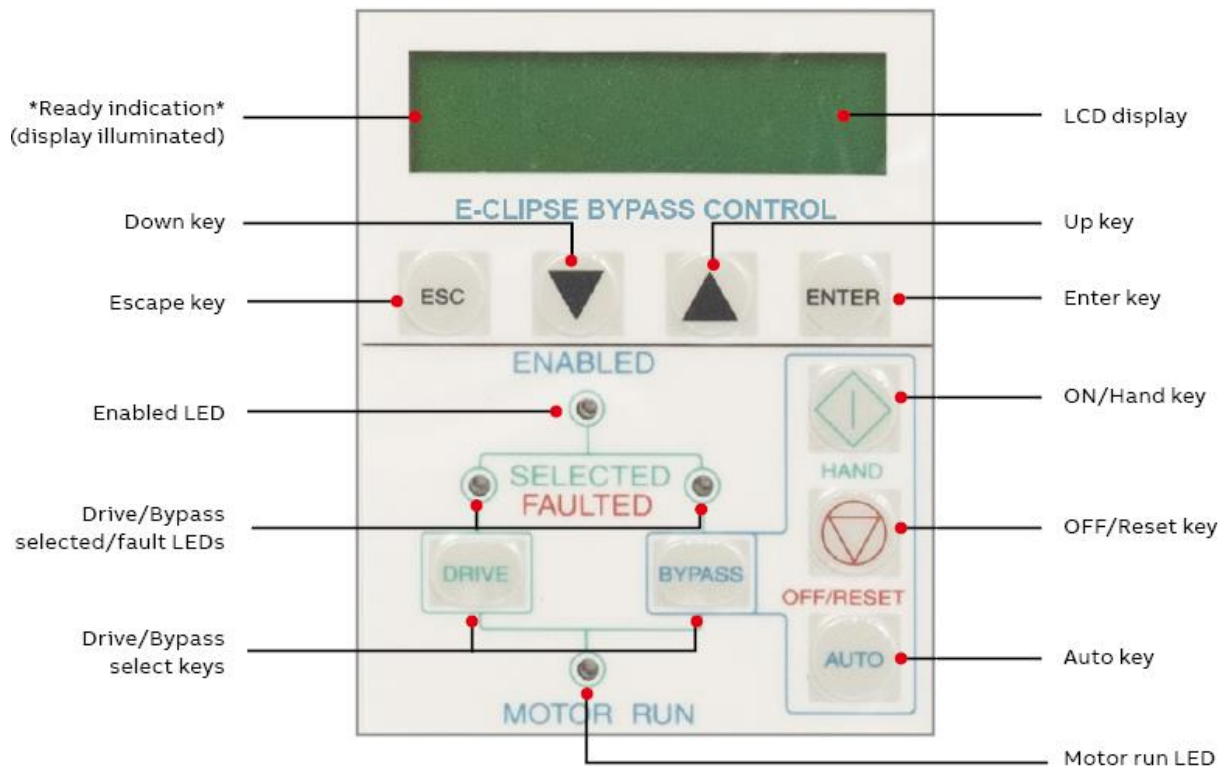

Cable connections

The following illustrations show the ACH580 with ABB E-Clipse bypass cable connection points for the various enclosure styles. The illustrations indicate the location of input and output power connections as well as equipment and motor grounding connection points.

ACH580 drives are configured for wiring access from the bottom only on Vertical ABB E-Clipse bypass units and from the top only on Standard ABB E-Clipse bypass units. At least three separate metallic conduits are required, one for input power, one for output power to the motor and one for control signals.

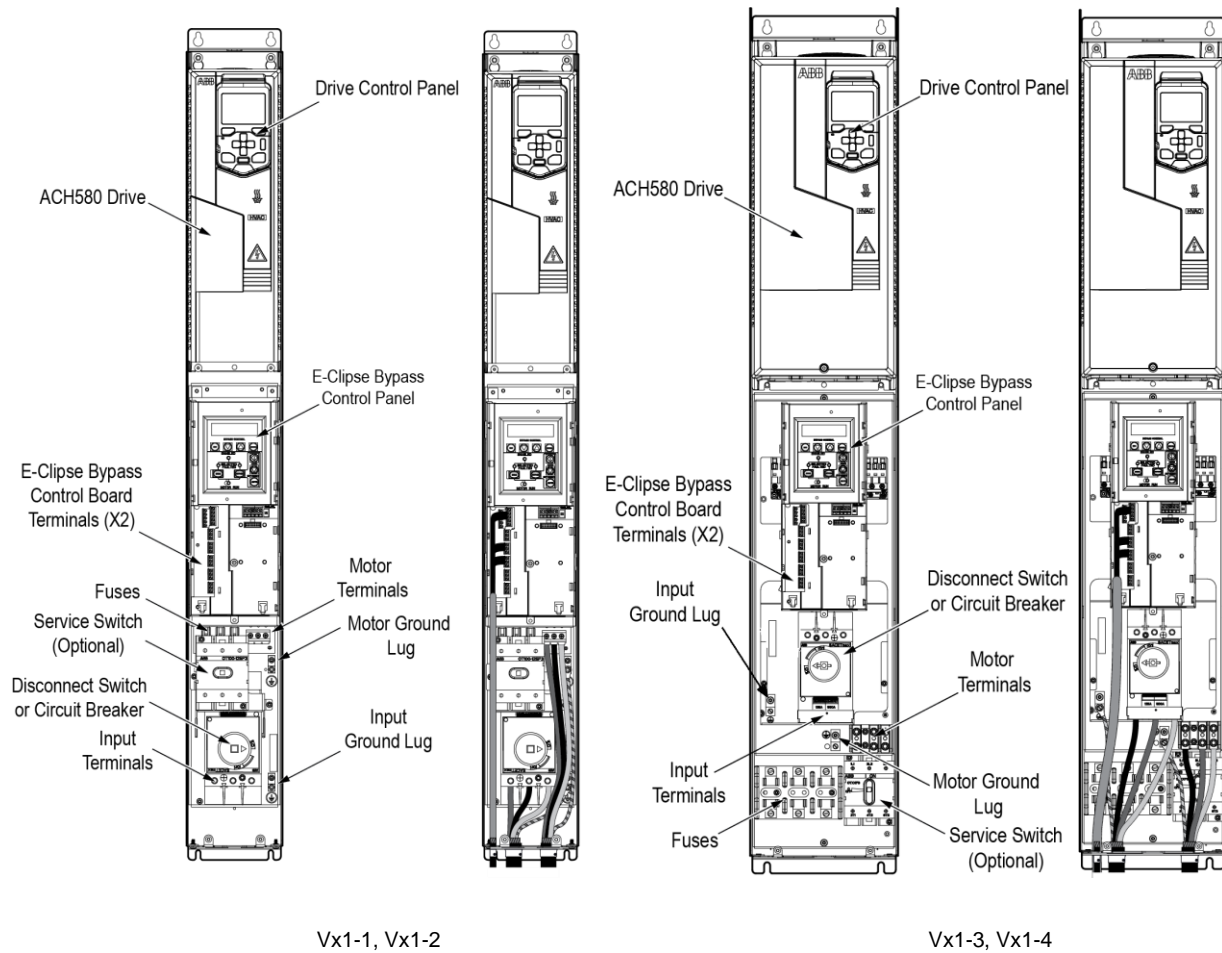

Cable connections

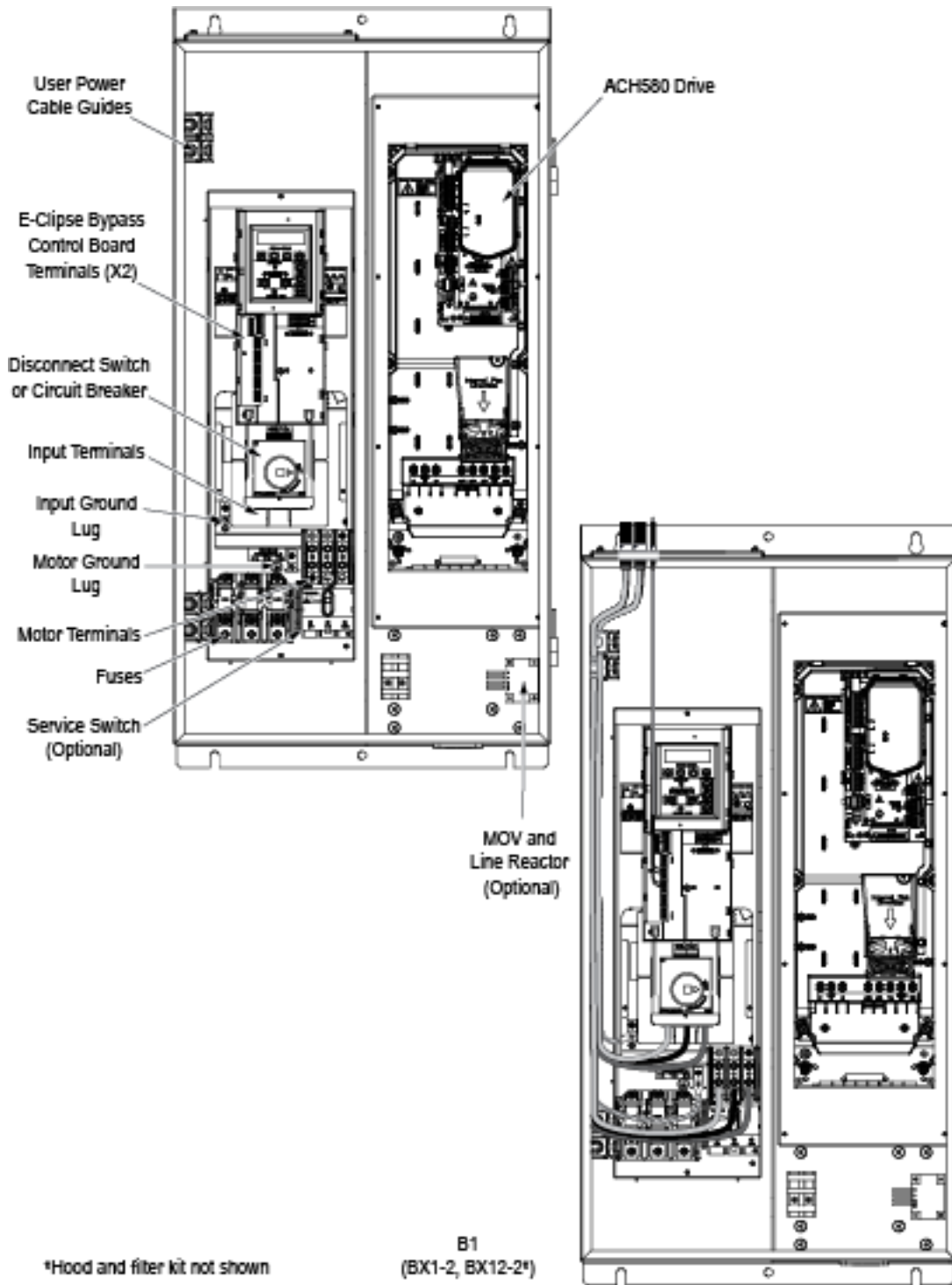

Bx1-1, Bx12-1, Bx3R-1

Control connections

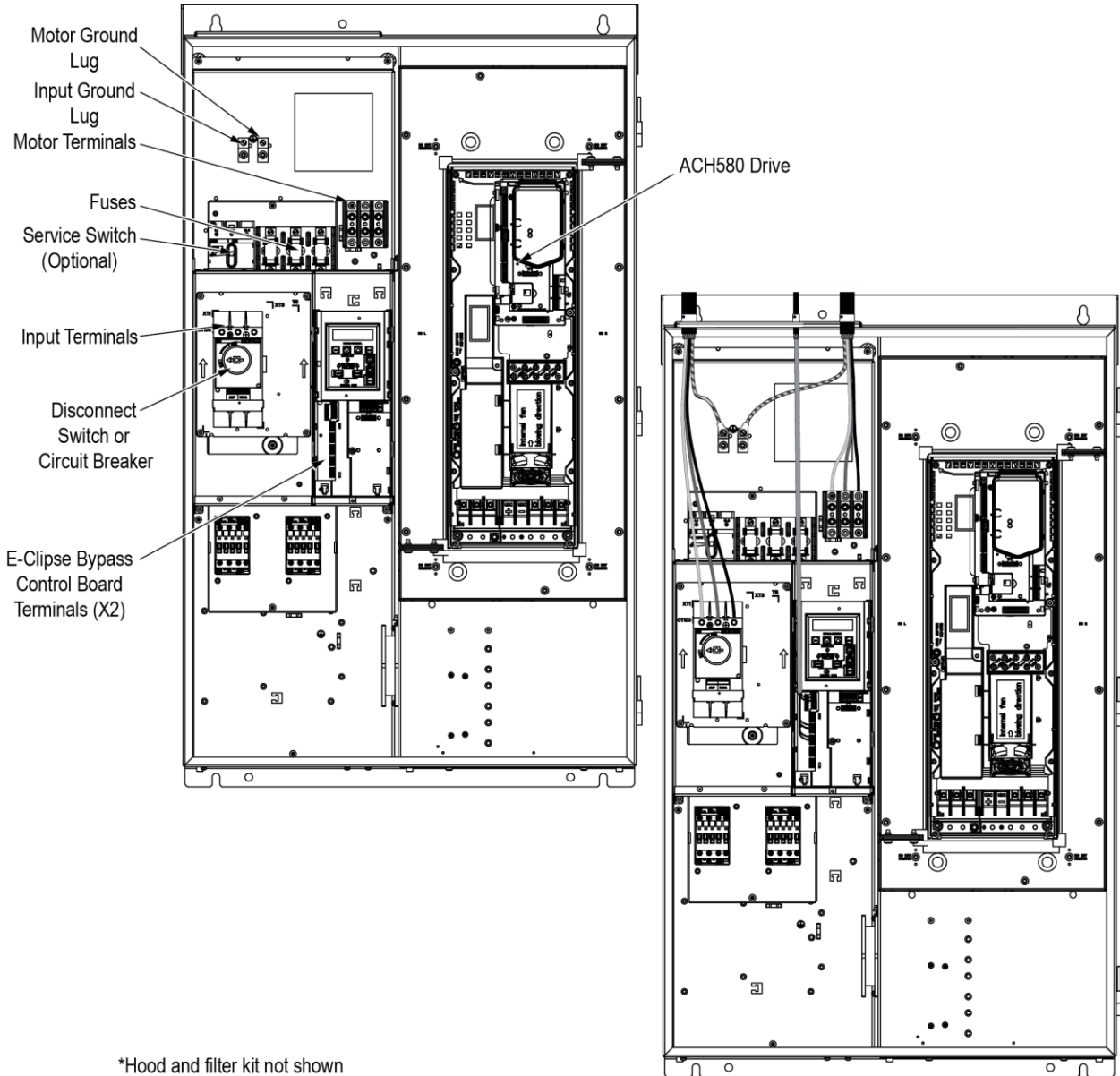

Bx1-3*, Bx12-3*

Control connections

The control wiring includes connections to an analog speed command signal and a start/stop relay contact for controlling the motor in the AUTO mode. There may also be connections to external run permissive interlock contacts and a connection from the Motor Run contact to an external status indication circuit. For a detailed description of the control circuit functions and alternate Control Connection diagrams, refer to the ACH580 E-Clipse bypass and packaged drive manual.

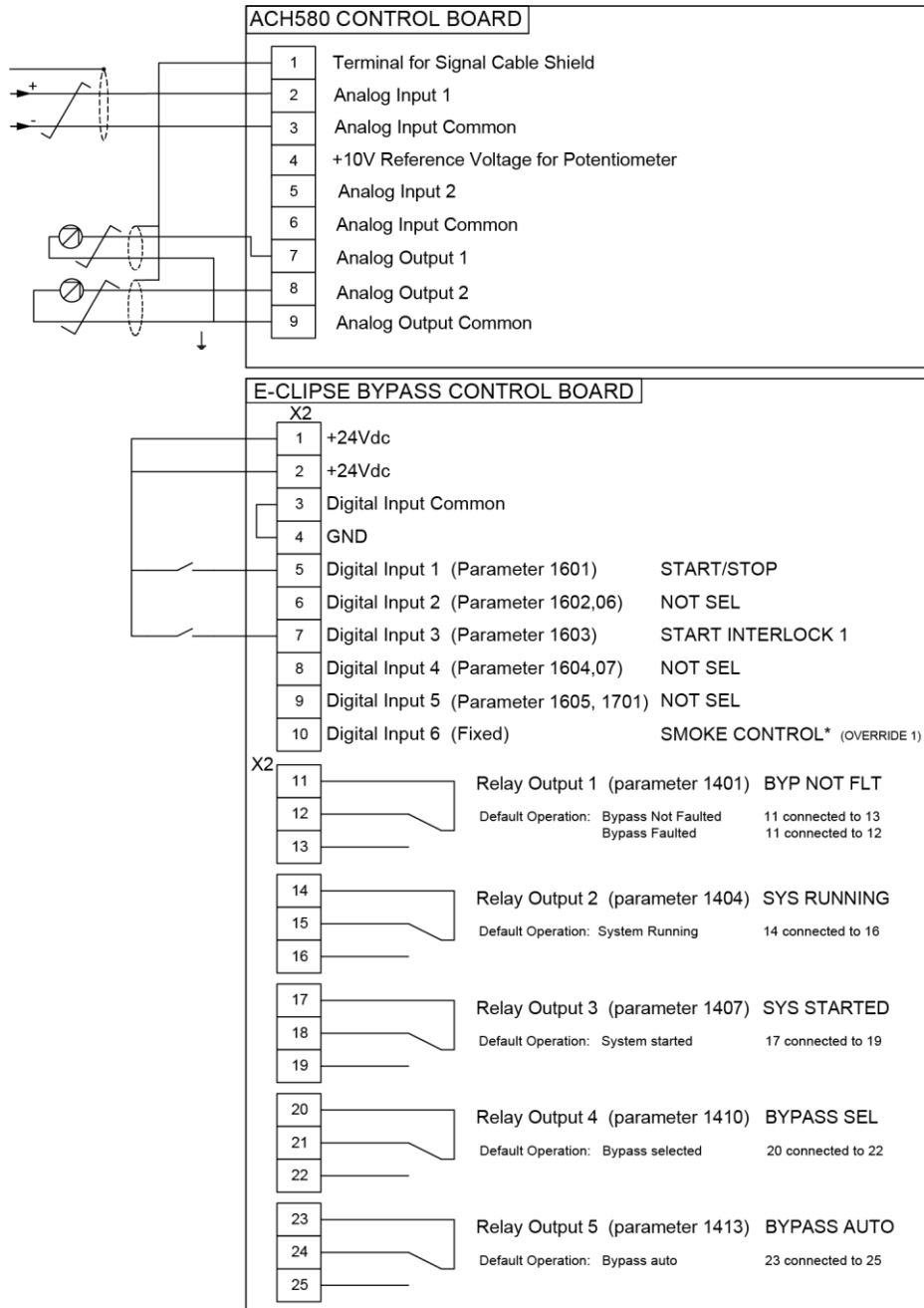

Engineering Data Summary

Replacement Fuses

Drive input fuses are recommended to disconnect the drive from power in the event that a component fails in the drive's power circuitry. Recommended drive input fuse specifications are listed in the *Submittal Schedule Details* and in the *Fuse Ratings Table*. Fuse rating information is provided for customer reference.

Item	Catalog Number	Drive Input Fuse Ratings	
		Amps (600V)	Bussmann Type
1	ACH580-VDR-03A5-4	15	Class CC

Terminal Sizes / Cable Connection Requirements

Power and motor cable terminal sizes and connection requirements are shown in the *Submittal Schedule Details* and in the *Terminal Sizes / Cable Connection Requirements Table*. The information provided below is for connections to input power and motor cables. These connections may be made to an input circuit breaker or disconnect switch, a motor terminal block, overload relay, and/or directly to bus bars and ground lugs. The table also lists torque that should be applied when tightening terminals and spacing requirements where multiple mounting holes are provided in the bus bar.

Item	Catalog Number	Input Wiring	Output Wiring	Ground Wiring
1	ACH580-VDR-03A5-4	#14...#4 4.6 lbf-ft	#20...#6 1.2 lbf-ft	#14...#4 3 lbf-ft

Heat Dissipation Requirements

The cooling air entering the drive must be clean and free from corrosive materials. The *Submittal Schedule Details* and the *Heat Dissipation Requirements* table below give the heat dissipated into the hot air exhausted from the drives. If the drives are installed in a confined space, the heat must be removed from the area by ventilation or air conditioning equipment.

Item	Catalog Number	Watts	BTU/Hr
1	ACH580-VDR-03A5-4	87	297

Dimensions and Weights

Dimensions and weights of the drives provided are given in the *Submittal Schedule Details* and in the *Dimensions and Weights Table*. The table also lists the applicable dimension drawings that include additional detail. Dimension drawings may be provided in the back of this submittal.

Item	Catalog Number	Height mm (in)	Width mm (in)	Depth mm (in)	Weight kg (lbs)
1	ACH580-VDR-03A5-4	1021 (40.20)	137 (5.40)	268 (10.56)	13.6 (30)

Product Short Circuit Current Rating

Short circuit ratings shown below are as show on the device rating label.

Item	Catalog Number	Short Circuit Current Rating
1	ACH580-VDR-03A5-4	100 kA with fusing

Item 1	Part Number ACH580-VDR-03A5-4	Customer Designation VFD-WEF-1
------------------	---	--

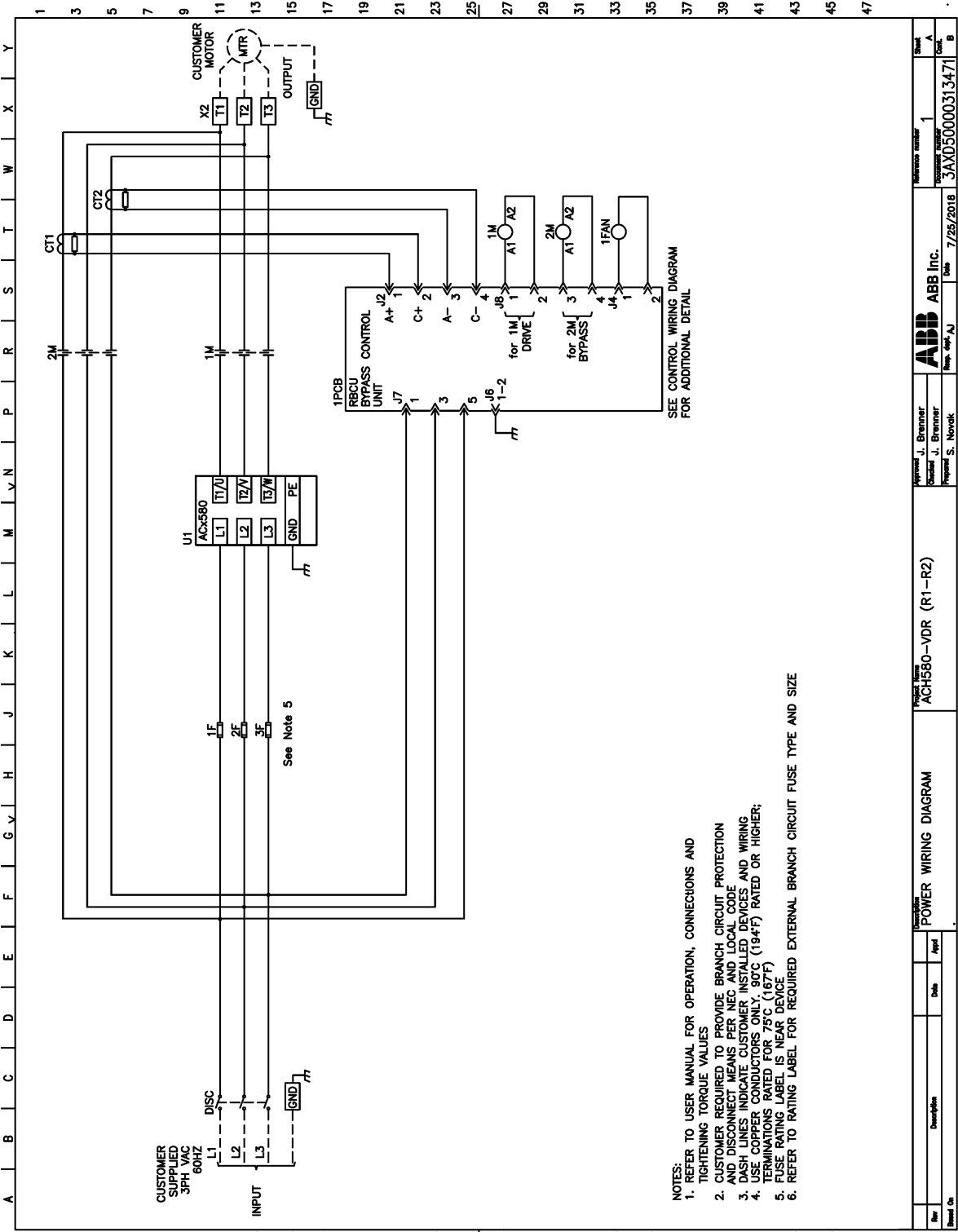

Revised On		Revised By		Revised Date		Part Number	ACH580-VDR (R1-R2)	Revision Number	1
Issue		Description		Date		Manufacturer	ABB ABB Inc.	Material Number	3AXD50000313471
Prepared	S. Novak	Checked	J. Brenner	Date	7/25/2018	Part Name	ACH580-VDR (R1-R2)	Revision Number	1
Approved	J. Brenner	Reviewed	J. Brenner	Date	7/25/2018	Part Name	ACH580-VDR (R1-R2)	Revision Number	1

{3AXD50000313471_1.png}

Item	Part Number	Customer Designation
1	ACH580-VDR-03A5-4	VFD-WEF-1

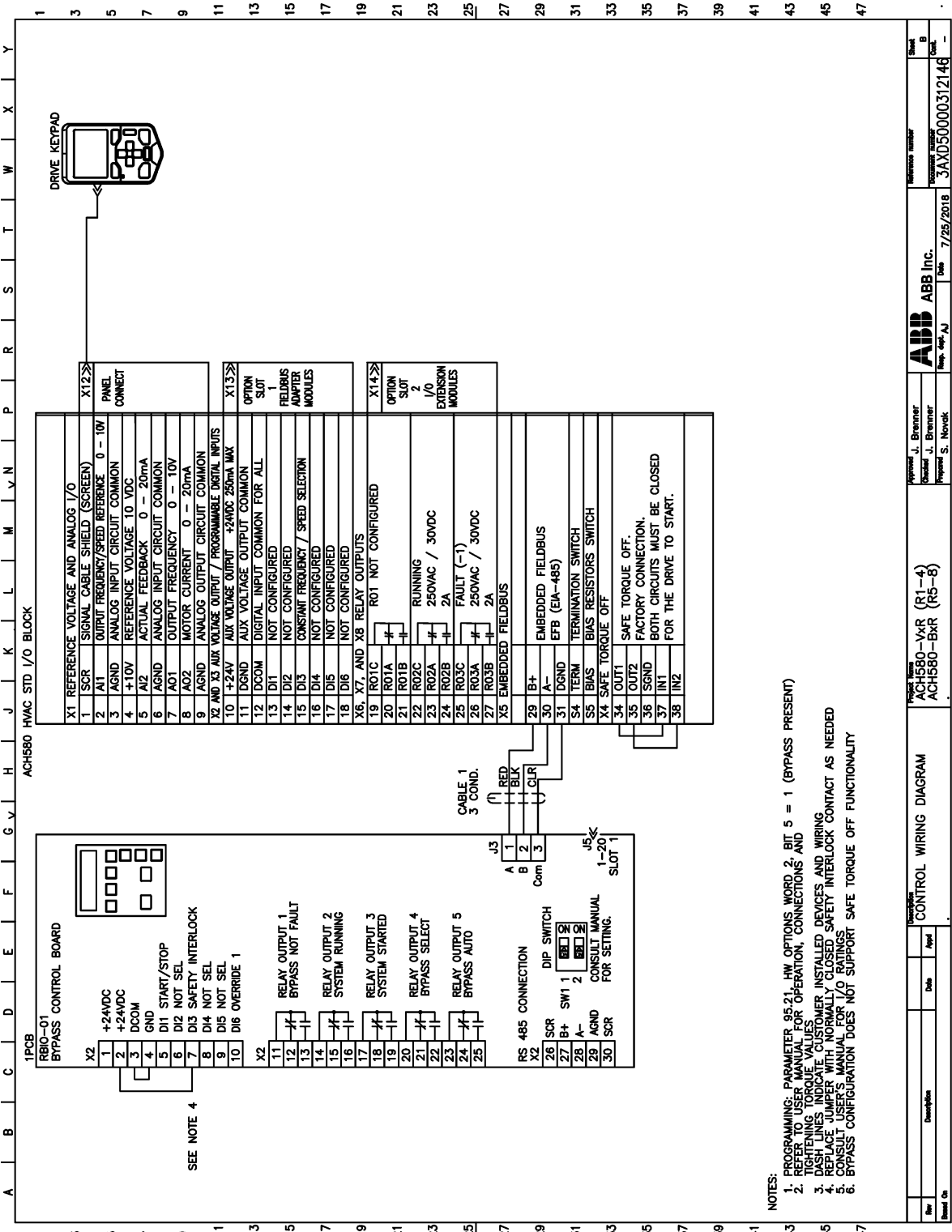

NOTES:

- PROGRAMMING: PARAMETER 95.21, HW OPTIONS WORD 2, BIT 5 = 1 (BYPASS PRESENT)
- REFER TO USER MANUAL FOR OPERATION, CONNECTIONS AND WIRING
- USING THIS INVERSE TORQUE ALUSE, THE USER MUST INSTALLER INSTALLED DEVICES AND WIRING
- REPLACE JUMPER WITH NORMALLY CLOSED SAFETY INTERLOCK CONTACT AS NEEDED
- CONSULT USER'S MANUAL FOR I/O RATINGS
- BYPASS CONFIGURATION DOES NOT SUPPORT SAFE TORQUE OFF FUNCTIONALITY

Rev	Description	Date	App'd	Checked	Control Wiring Diagram	Project Name	ACH580-VxR (R1-4) ACH580-BxR (R5-8)	Prepared	S. Novak	Date	7/25/2018	Reference number	3AXD50000312146	Sheet	1 of 1

{3AXD50000312146.png}

Item 1	Part Number ACH580-VDR-03A5-4	Customer Designation VFD-WEF-1
------------------	---	--

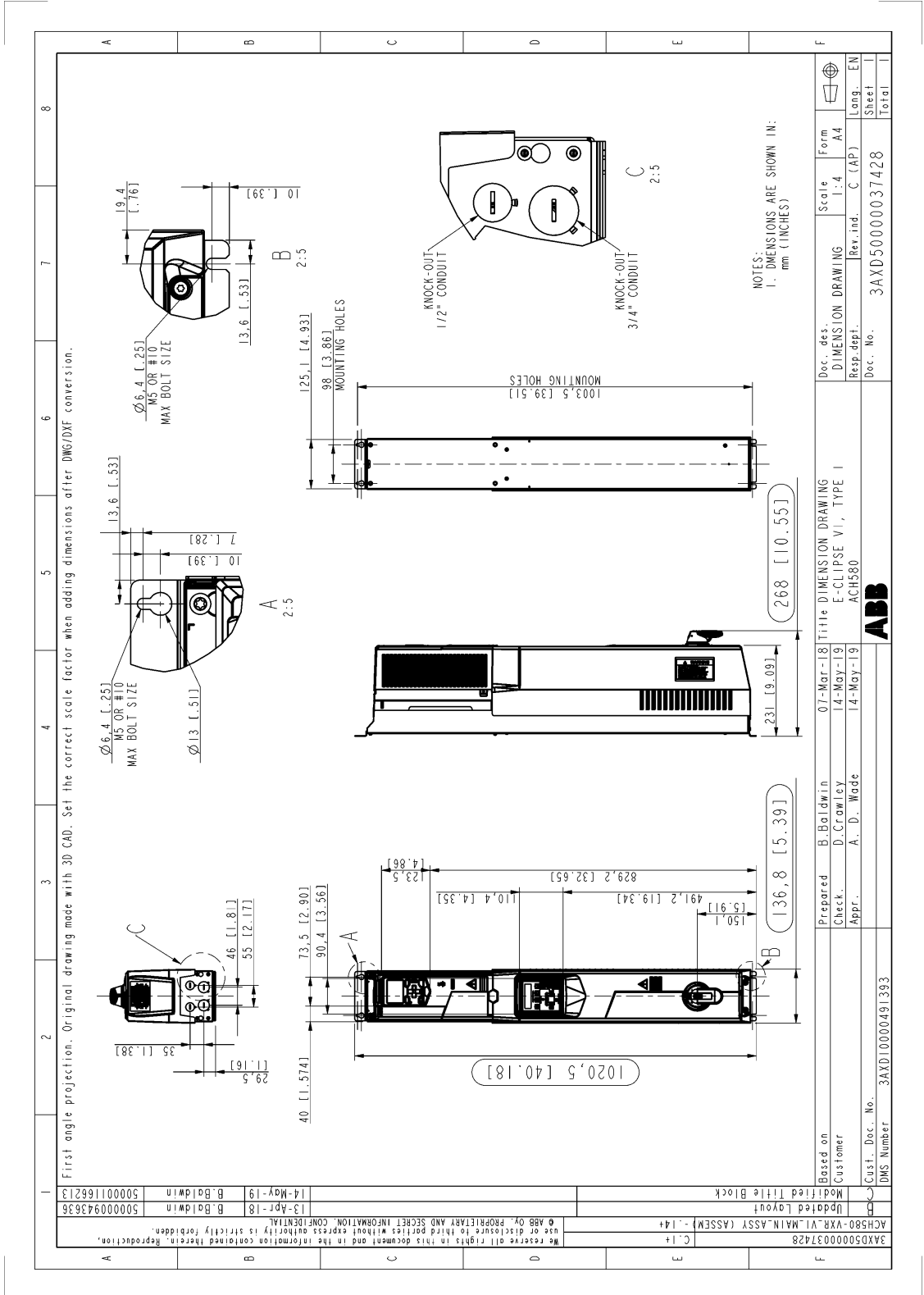

{3AXD50000037428.png}



Fantech

Dryer Booster Fan

DBF4XLT

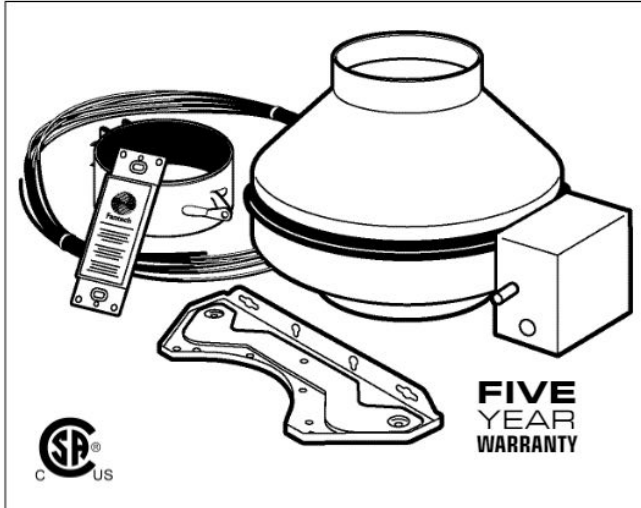

FEATURES

- Inline Dryer Booster Fan featuring self-cleaning backward curved impeller capable of maintaining an air velocity of 1200 fpm in duct systems up to 130 feet.'
- Galvanized steel housing with powder-coat finish
- Integrated Pressure Sensing Switch
- Wall-mount indicator panel
- Uses 4" duct
- 5 1/2 foot 120Vac power cord
- Mounting bracket and hardware included

The Fantech DBF4XLT Dryer Booster Fan has been specially designed to solve the problems caused by long duct runs on clothes dryers.

According to dryer manufacturers and some local building codes, booster fans should be added in the dryer duct run when the length of the duct exceeds 24 feet with no bends, 20 feet with one bend or 15 feet with two bends.

HOW DOES IT WORK:

When the dryer is on, Fantech's patented pressure sensing switch automatically turns the booster fan on. The warm, moist air in the dryer duct is exhausted out of the building quickly.

The dryer booster fan monitors the status of the dryer and will turn itself off when the dryer stops.

Wall mounted indicator panel with LED display lets homeowners know that fan is fully operational.

SPECIFICATIONS

FAN – Inline fan with galvanized steel housing and baked powder-coat finish. Backward inclined blades of the motorized impeller allow lint to pass through the fan.

PRESSURE SWITCH Fantech's patented pressure switch automatically activates the booster fan when dryer comes on. Includes 18" of pressure sensing tubing with mounting grommet.

INDICATOR PANEL Wall-mount, low voltage indicator panel features an LED light that indicates to the homeowner that the fan is working properly. The indicator panel will alert homeowners of problems such as no power, blocked duct, locked motor rotor and low speed conditions. A 50 foot cable is included to connect the indicator panel to the booster fan.

Fan Model	RPM	Volts	Max Watts	Max Amps	Static Pressure in Inches W.G.										Max Ps	Duct Dia.
					0"	.125"	.25"	.375"	.5"	.75"	1.0"	1.25"	1.5"			
DBF4XLT	2800	115	83	0.73	195	181	167	153	141	120	101	81	55	2.05"	4"	

Distributed by:

DIMENSIONS AND AIRFLOW All units feature 5 1/2 foot plug-in power cord.

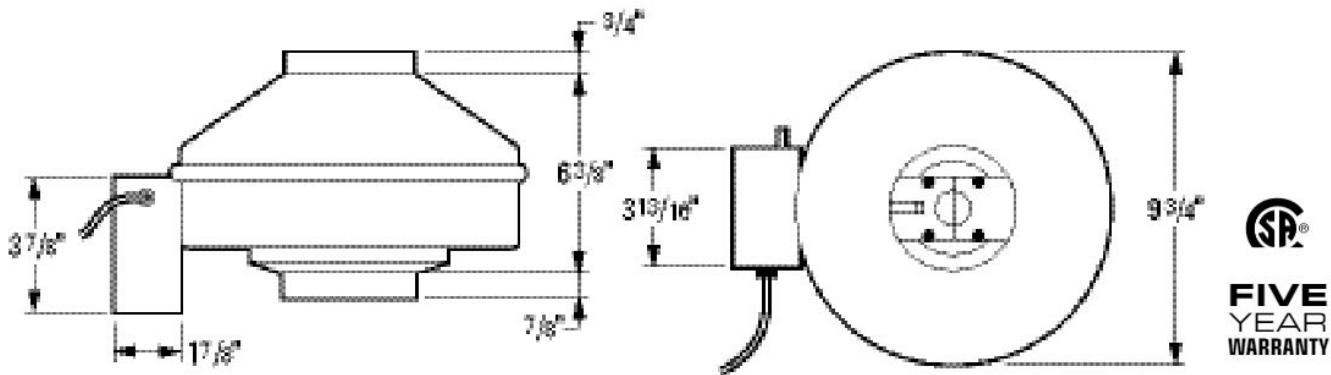

VENTILATION PERFORMANCE

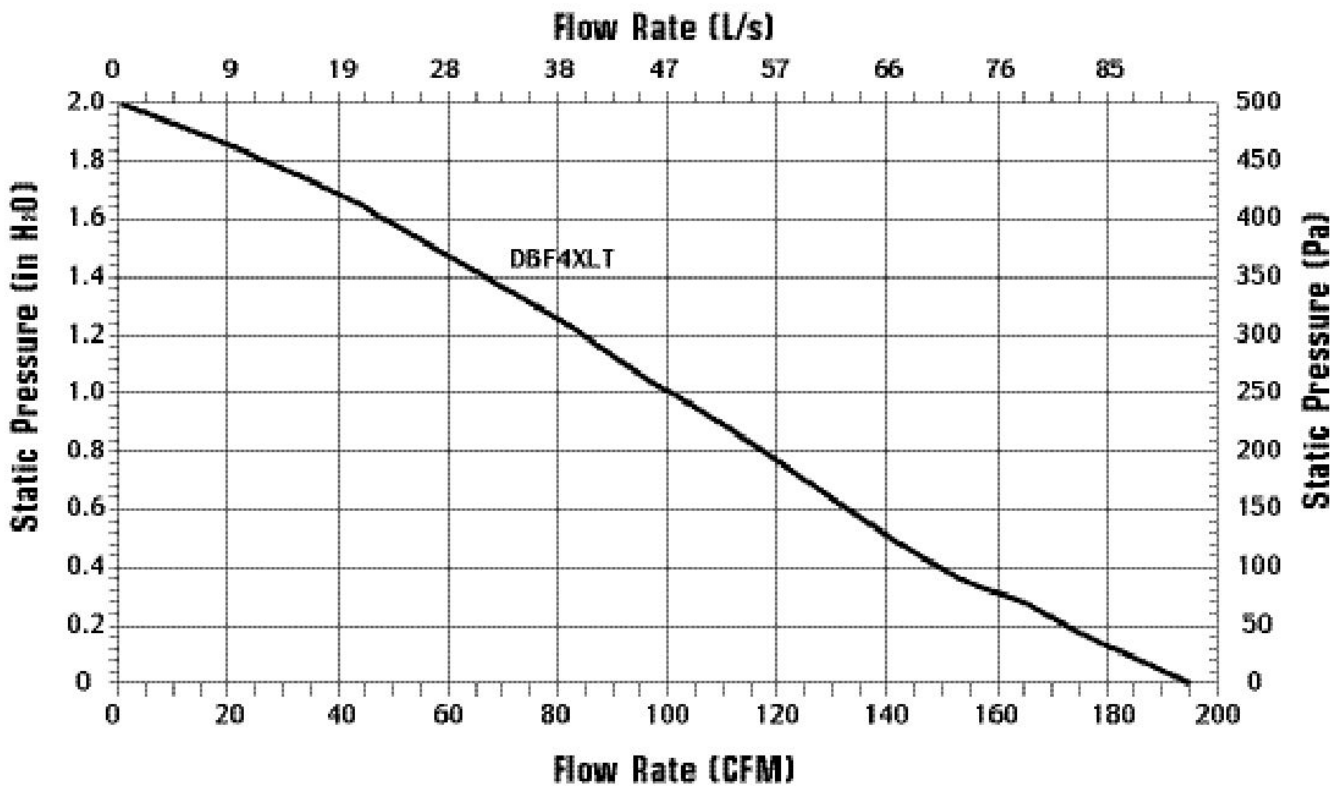

CONTACTS

Submitted by:	Date:
Qty:	Model #:
Comments:	
Project #:	
Location:	
Architect:	
Engineer:	
Contractor:	



United States

1712 Northgate Blvd.
 Sarasota, FL 34234
 Phone: 800.747.1762; 941.309.6000
 Fax: 800.487.9915; 941.309.6099
www.fantech.net; info@fantech.net

Canada

50 Kanalfakt Way
 Bouctouche, NB E4S 3M5
 Phone: 800.565.3548; 506.743.9500
 Fax: 877.747.8116; 506.743.9600
www.fantech.ca; info@fantech.ca

DBLT 4W

Secondary Dryer Lint Trap







United States

10048 Industrial Blvd., Lenexa, KS, 66215
Tel.: 800.747.1762 • Fax: 800.487.9915

Canada

50 Kanalfakt Way, Bouctouche, NB, E4S 3M5
Tel.: 800.565.3548 • Fax: 877.747.8116

				
Note	Warning / Important note	Information	Technical information	Practical tip



READ AND SAVE THESE INSTRUCTIONS

1. The DBLT4W is a Secondary Dryer Lint Trap used when installing Fantech Dryer Booster Fan less than the recommended distance of 15 feet from the back of the dryer.
2. Please, observe the following:
 - a. The Lint Trap must be installed so it is easily accessible to the dryer user.
 - b. The lid can be rotated for the most secure fit.
 - c. It is recommended the dryer user inspect for lint accumulation prior to operation of the dryer.

3. REMOVE LINT AS REQUIRED TO KEEP THE SCREEN CLEAN.



Normally the DBLT4W is installed in the dryer duct just above the dryer (see the reference on the left).

WARRANTY

Five (5) Year Warranty

This warranty supersedes all prior warranties

DURING ENTIRE WARRANTY PERIOD:

Fantech will repair or replace any part which has a factory defect in workmanship or material. Product may need to be returned to the Fantech factory, together with a copy of the bill of sale and identified with RMA number.

FOR FACTORY RETURN YOU MUST:

- Have a Return Materials Authorization (RMA) number. This may be obtained by calling Fantech either in the USA at 1.800.747.1762 or in CANADA at 1.800.565.3548. Please have bill of sale available.
- The RMA number must be clearly written on the outside of the carton, or the carton will be refused.
- All parts and/or product will be repaired/replaced and shipped back to buyer; no credit will be issued.

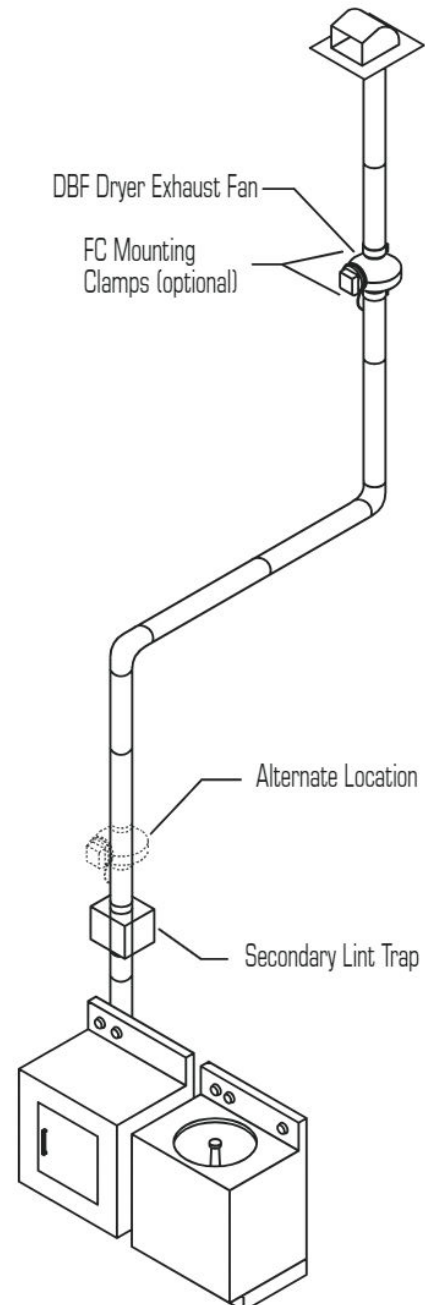

WARRANTY

The Distributor may place an order for the warranty part and/or product and is invoiced. The Distributor will receive a credit equal to the invoice only after product is returned prepaid and verified to be defective.

FANTECH WARRANTY TERMS DO NOT PROVIDE FOR REPLACEMENT WITHOUT CHARGE PRIOR TO INSPECTION FOR A DEFECT. REPLACEMENTS ISSUED IN ADVANCE OF DEFECT INSPECTION ARE INVOICED, AND CREDIT IS PENDING INSPECTION OF RETURNED MATERIAL. DEFECTIVE MATERIAL RETURNED BY END USERS SHOULD NOT BE REPLACED BY THE DISTRIBUTOR WITHOUT CHARGE TO THE END USER, AS CREDIT TO DISTRIBUTOR'S ACCOUNT WILL BE PENDING INSPECTION AND VERIFICATION OF ACTUAL DEFECT BY FANTECH.

THE FOLLOWING WARRANTIES DO NOT APPLY:

- Damages from shipping, either concealed or visible. Claim must be filed with freight company.
- Damages resulting from improper wiring or installation.
- Damages or failure caused by acts of God, or resulting from improper consumer procedures, such as:
 1. Improper maintenance
 2. Misuse, abuse, abnormal use, or accident, and
 3. Incorrect electrical voltage or current.
- Removal or any alteration made on the Fantech label control number or date of manufacture.
- Any other warranty, expressed, implied or written, and to any consequential or incidental damages, loss or property, revenues, or profit, or costs of removal, installation or reinstallation, for any breach of warranty.

WARRANTY VALIDATION

- The user must keep a copy of the bill of sale to verify purchase date.
- These warranties give you specific legal rights, and are subject to an applicable consumer protection legislation. You may have additional rights which vary from state to state.

DIMENSIONS

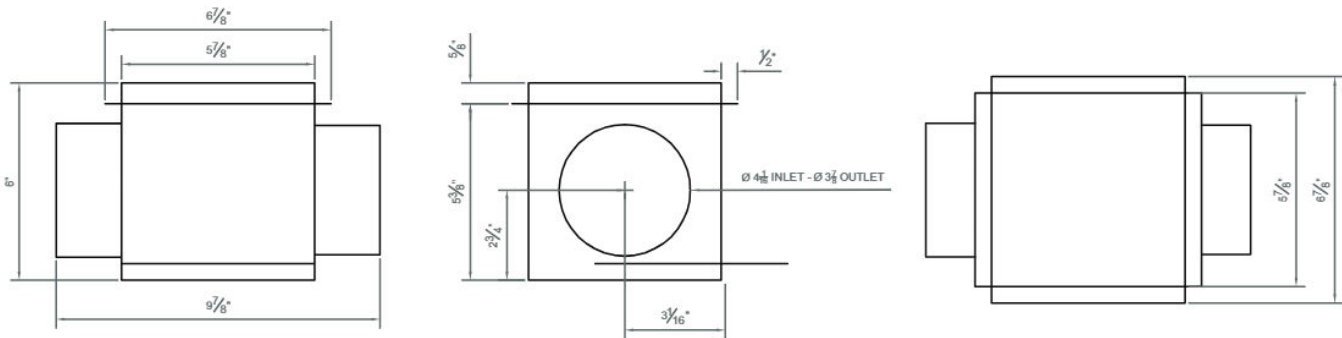

DBLT 4W. Housing

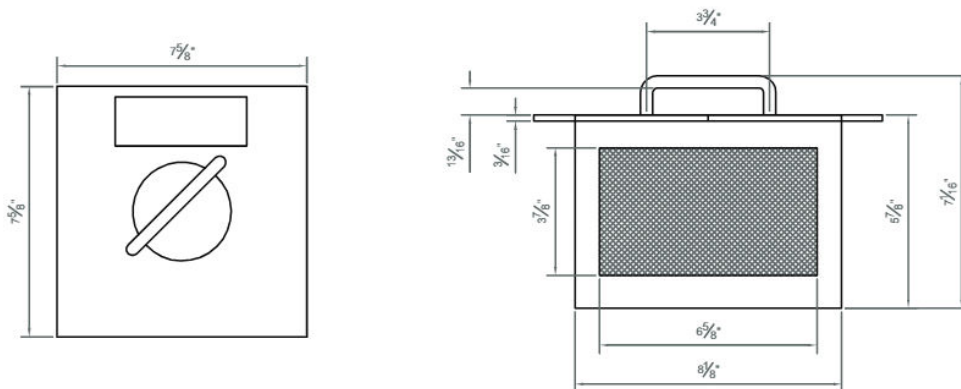

DBLT 4W. Door / Screen Assembly

Fantech reserves the right to make technical changes.
For updated documentation please refer to www.fantech.net

Fantech®



SUBMITTAL

PRODUCT	Gravity Ventilators
MANUFACTURER	Loren Cook
JOB NAME	Southside High & Junior High Additions
LOCATION	Southside, AR
ENGINEER	Lewis Architects Engineers
CONTRACTOR	Middleton, Inc.
DATE	7/26/2023
SUBMITTED BY	Courtney Michael

5440 Northshore Drive - North Little Rock, Arkansas 72118 - Tel: 501.374.5420 Fax: 501.370.9298



COOK

MARK: GEV-1,4,5,7

PROJECT: SOUTHSIDE HIGH SCHOOL AND JUNIOR HI...

DATE: 7/24/2023

PR

Spun Aluminum Intake/Relief Ventilator

STANDARD CONSTRUCTION FEATURES:

All aluminum construction - Anti-backdraft flange - Five year warranty.

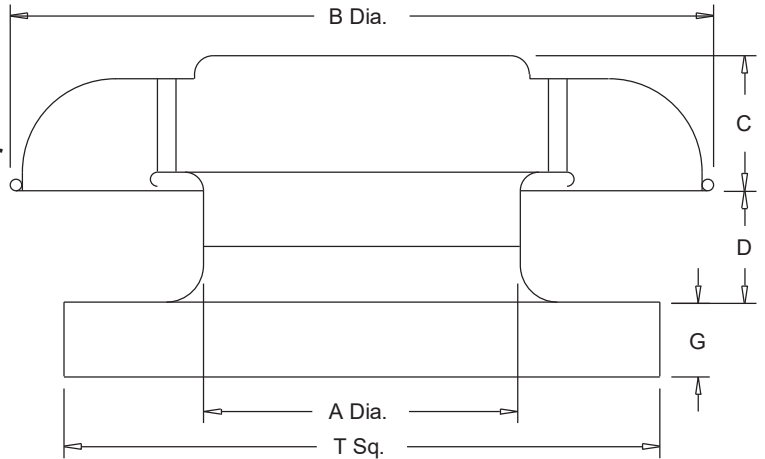

Performance

Qty	Catalog Number	Flow (CFM)	SP (inwc)
4	16 PR	917	.050

Altitude (ft): 1270 Temperature (F): 70

Accessories:

BD-22 DAMPER
ROOF CURB RCG 26 13.5H -C+T+N
BIRDSCREEN

Dimensions (inches)

A Dia.	16-1/2
B Dia.	27-3/4
C	5-1/16
D	5-1/2
G	2
T Sq.	28
Roof Open.	23-1/2

NOTE: Accessories may affect dimensions shown.

Weight(lbs)***	Shipping	72	Unit	66
----------------	----------	----	------	----

***Includes accessories.



BD

Gravity Backdraft Damper

STANDARD CONSTRUCTION FEATURES:

- .020 Aluminum blades - .060 aluminum frame -
- Aluminum hinge pins - Nylon bushings.

Notes:

- Max. operating temperature 200 Deg F (95 Deg C).
- Max. discharge velocity 2000 fpm.
- Sizes 36 thru 60 are shipped as 2 panels.
- Sizes 66 and 78 are shipped as 6 panels.
- These may require assembly.

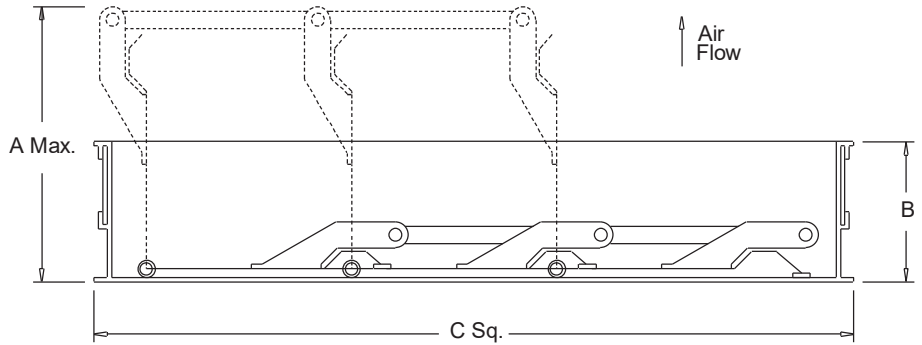

Dimensions (inches)

Mark	Qty	Description	A Max.	B	C Sq.	# Panels
GEV-1,4,5,7	4	BD-22 DAMPER	5-3/16	1-7/8	21-3/4	1



RCG

Galvanized Steel Roof Curb

STANDARD CONSTRUCTION FEATURES:

18 gauge galvanized steel - 1-1/2",
3 lbs. density thermal and acoustical
insulation - Continuously welded corners -
Wood nailer.

Options:(As noted below*)

- 1) No wood nailer (deduct 1-1/2" for actual height).
- 2) Damper tray.
- 3) Liner.
- 4) Gasket on wood nailer.
- 5) Lorenized coating.
- 6) Enamel coating.
- 7) Burglar bars.

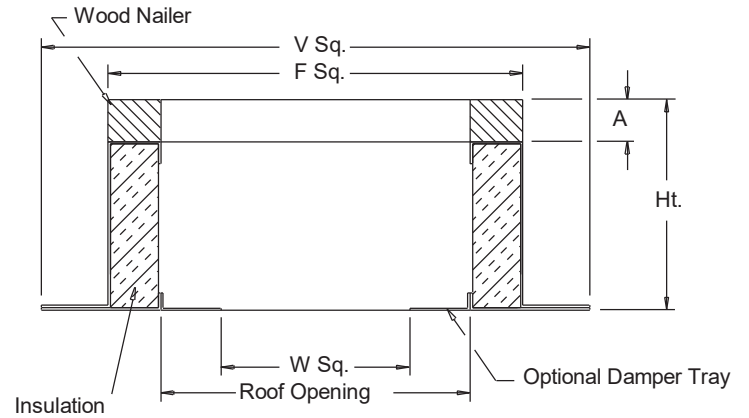

Dimensions (inches)

Mark	Qty	Description	Ht	Options*	A	F Sq.	V Sq.	W Sq.	Roof Opening
GEV-1,4,5,7	4	RCG 26	13.5	2;	1-1/2	26-1/2	30-1/2	19-3/4	23-1/2



COOK

MARK: GEV-2,3

PROJECT: SOUTHSIDE HIGH SCHOOL AND JUNIOR HI...

DATE: 7/24/2023

PR

Spun Aluminum Intake/Relief Ventilator

STANDARD CONSTRUCTION FEATURES:

All aluminum construction - Anti-backdraft flange - Five year warranty.

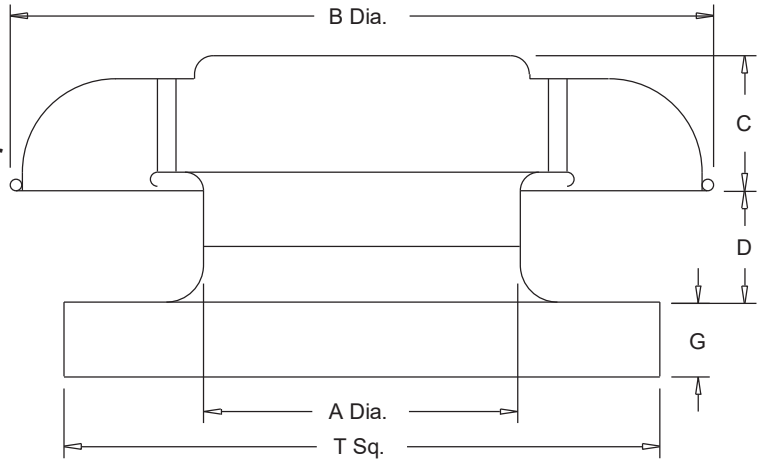

Performance

Qty	Catalog Number	Flow (CFM)	SP (inwc)
2	8 PR	247	.050

Altitude (ft): 1270 Temperature (F): 70

Accessories:

BD-12 DAMPER
ROOF CURB RCG 16 13.5H -C+T+N
BIRDSCREEN

Dimensions (inches)

A Dia.	8-5/8
B Dia.	18-3/4
C	4-5/8
D	3-1/2
G	2
T Sq.	18
Roof Open.	13-1/2

NOTE: Accessories may affect dimensions shown.

Weight(lbs)***	Shipping	39	Unit	35
----------------	----------	----	------	----

***Includes accessories.



BD

Gravity Backdraft Damper

STANDARD CONSTRUCTION FEATURES:

- .020 Aluminum blades - .060 aluminum frame -
- Aluminum hinge pins - Nylon bushings.

Notes:

Max. operating temperature 200 Deg F (95 Deg C).

Max. discharge velocity 2000 fpm.

Sizes 36 thru 60 are shipped as 2 panels.

Sizes 66 and 78 are shipped as 6 panels.

These may require assembly.

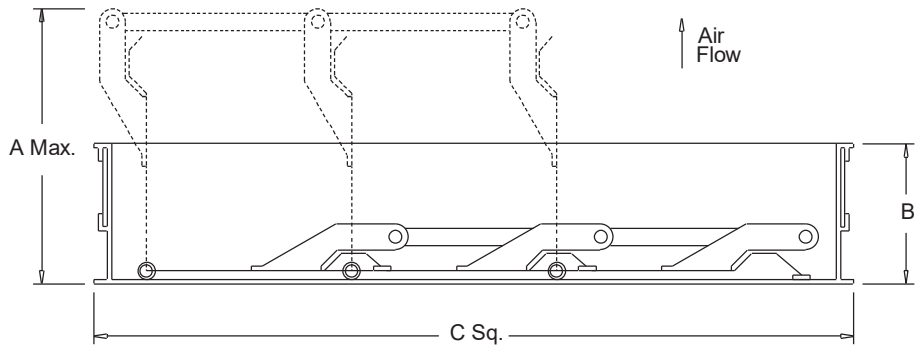

Dimensions (inches)

Mark	Qty	Description	A Max.	B	C Sq.	# Panels
GEV-2,3	2	BD-12 DAMPER	5-3/16	1-7/8	11-3/4	1



RCG

Galvanized Steel Roof Curb

STANDARD CONSTRUCTION FEATURES:

18 gauge galvanized steel - 1-1/2",
 3 lbs. density thermal and acoustical insulation - Continuously welded corners - Wood nailer.

Options:(As noted below*)

- 1) No wood nailer (deduct 1-1/2" for actual height).
- 2) Damper tray.
- 3) Liner.
- 4) Gasket on wood nailer.
- 5) Lorenized coating.
- 6) Enamel coating.
- 7) Burglar bars.

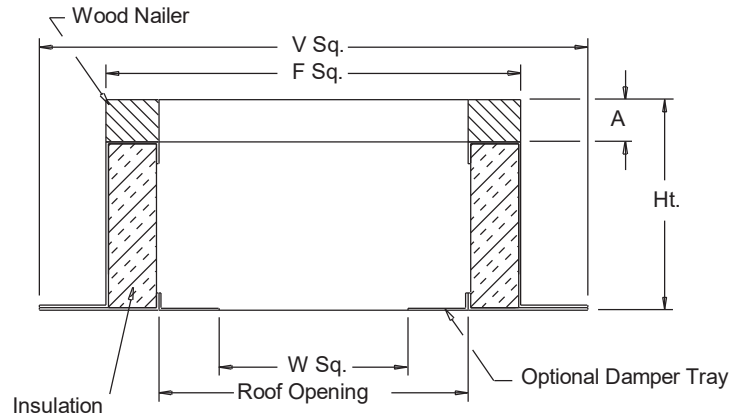

Dimensions (inches)

Mark	Qty	Description	Ht	Options*	A	F Sq.	V Sq.	W Sq.	Roof Opening
GEV-2,3	2	RCG 16	13.5	2;	1-1/2	16-1/2	20-1/2	9-3/4	13-1/2



COOK

MARK: GEV-6

PROJECT: SOUTHSIDE HIGH SCHOOL AND JUNIOR HI...

DATE: 7/24/2023

PR

Spun Aluminum Intake/Relief Ventilator

STANDARD CONSTRUCTION FEATURES:

All aluminum construction - Anti-backdraft flange - Five year warranty.

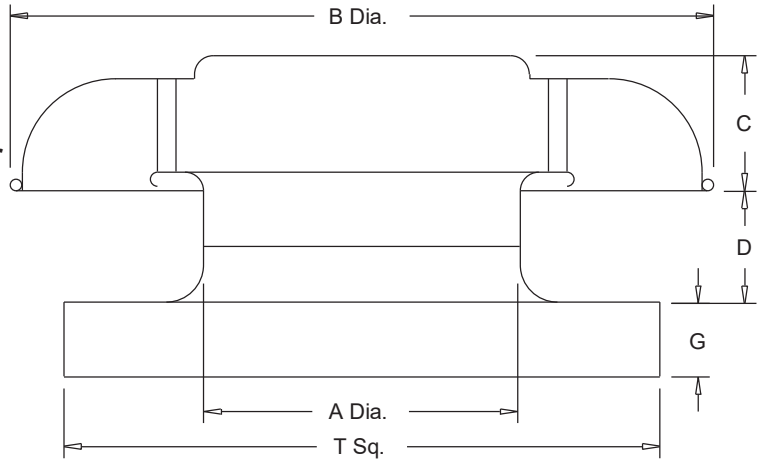

Performance

Qty	Catalog Number	Flow (CFM)	SP (inwc)
1	12 PR	519	.050

Altitude (ft): 1270 Temperature (F): 70

Accessories:

BD-14 DAMPER
ROOF CURB RCG 18 13.5H -C+T+N
BIRDSCREEN

Dimensions (inches)

A Dia.	12-1/2
B Dia.	27-3/4
C	5-1/16
D	3-1/2
G	2
T Sq.	20
Roof Open.	15-1/2

NOTE: Accessories may affect dimensions shown.

Weight(lbs)***	Shipping	52	Unit	46
----------------	----------	----	------	----

***Includes accessories.



BD

Gravity Backdraft Damper

STANDARD CONSTRUCTION FEATURES:

- .020 Aluminum blades - .060 aluminum frame -
- Aluminum hinge pins - Nylon bushings.

Notes:

Max. operating temperature 200 Deg F (95 Deg C).

Max. discharge velocity 2000 fpm.

Sizes 36 thru 60 are shipped as 2 panels.

Sizes 66 and 78 are shipped as 6 panels.

These may require assembly.

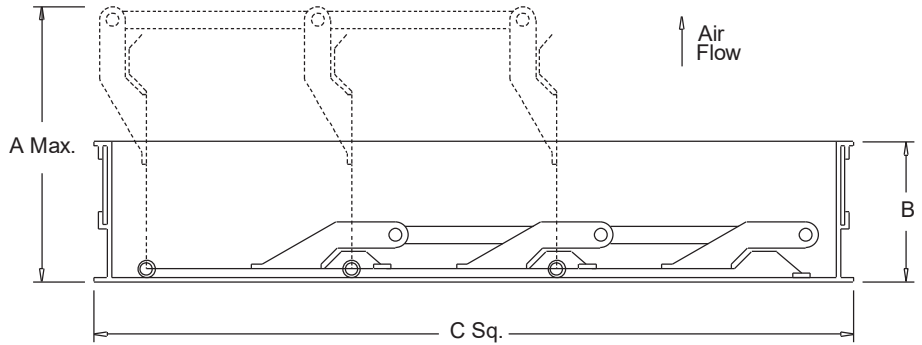

Dimensions (inches)

Mark	Qty	Description	A Max.	B	C Sq.	# Panels
GEV-6	1	BD-14 DAMPER	5-3/16	1-7/8	13-3/4	1



RCG

Galvanized Steel Roof Curb

STANDARD CONSTRUCTION FEATURES:

18 gauge galvanized steel - 1-1/2",
 3 lbs. density thermal and acoustical insulation - Continuously welded corners - Wood nailer.

Options:(As noted below*)

- 1) No wood nailer (deduct 1-1/2" for actual height).
- 2) Damper tray.
- 3) Liner.
- 4) Gasket on wood nailer.
- 5) Lorenized coating.
- 6) Enamel coating.
- 7) Burglar bars.

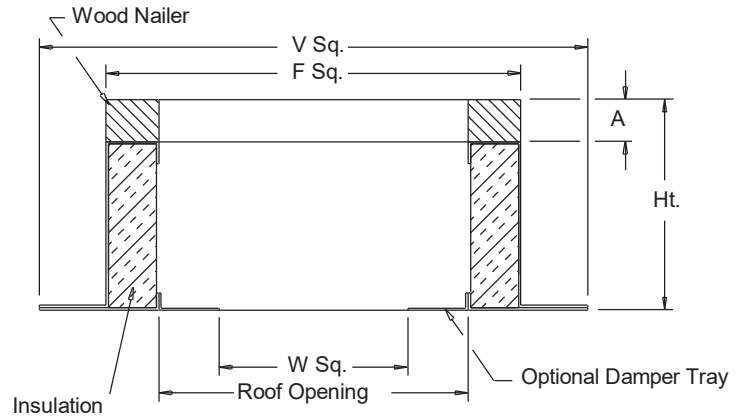

Dimensions (inches)

Mark	Qty	Description	Ht	Options*	A	F Sq.	V Sq.	W Sq.	Roof Opening
GEV-6	1	RCG 18	13.5	2;	1-1/2	18-1/2	22-1/2	11-3/4	15-1/2