

Quality People. Building Solutions.

Comfort Systems USA (Arkansas), Inc.
P.O. Box 16620
Little Rock, AR 72231
Phone 501-834-3320
Fax 501-834-5416

Date: 11/28/2023

Return Request: 12/5/2023

Project: MAC Building – 4th Floor

Supplier: Comfort Systems USA (Arkansas), Inc.

Manufacturer: Various

Submittal: Hangers & Supports

Submittal Number: 23 05 29-01

Drawing # and Installation: Mechanical Drawings

ARCHITECT

Stocks Mann
401 W. Capitol, Suite 402
Little Rock, AR 72201
501-370-9207

ENGINEER

Insight
322 S. State Street, Suite 201
Little Rock, AR 72201
501-237-3077

GENERAL CONTRACTOR

Carson & Associates
1310 W. Daisy Bates Dr.
Little Rock, AR 72202
501-372-5816

MECHANICAL SUBCONTRACTOR

Comfort Systems USA (Arkansas), Inc.
9924 Landers Rd.
N. Little Rock, AR 72117
501-834-3320

Notes:

chowell@comfortar.com

9924 Landers Rd.
No. Little Rock, AR 72117

Adjustable Clevis Hanger Fig. 260 (Formerly Afcon Fig. 371)

Size Range: ½" through 30"

Material: Carbon Steel

Finish: Plain, 8" & Smaller: Zinc Plated (Hot-Dip Galvanized optional), 10" & Larger: Hot-Dip Galvanized with Zinc Plated Bolts & Nuts, or Primed, also available in Plastic or Epoxy Coated.

Service: Recommended for the suspension of stationary pipe lines.

Maximum Temperature: Plain 650° F, Galvanized and Epoxy 450° F

Approvals: Complies with Federal Specification A-A-1192A (Type 1), WW-H-171-E (Type 1), ANSI/MSS SP-69 and MSS SP-58 (Type 1). FM Approved (Sizes ¾" through 8"), UL and ULC Listed (Sizes ½" through 8").

Installation: Hanger load nut above clevis must be tightened securely to assure proper hanger performance.

Adjustment: Vertical adjustment without removing pipe may be made from ¾" through 5/8", varying with the size of clevis. Tighten upper nut after adjustment.

Features:

- Design has yoke on outside of lower U-strap so yoke cannot slide toward center of bolt, thus bending of bolt is minimized.
- Sizes 5" and up have rod and two nuts instead of bolt and nut; thread length on clevis rod is such that the thread locks the nuts in place, and threads are not in shear plane.

Ordering:

Specify pipe size, figure number, name and finish.

Notes:

- Punched forming holes may be present on certain sizes of this clevis hanger. These holes are solely for the purpose of manufacturing, and do not effect the structural integrity or load carrying capacities of these hangers.
- For insulated line options without shields, see Figures 260 ISS and Figure 300. For insulated line options with shields, see Figures 167 and 168. For ductile iron pipe sizes, see Figure 590.
- Fig. 260F (Felt lined) – available for use for suspension of copper (or other material) so as to prevent electrolysis between the dissimilar metals of the hanger and the pipe, tube or conduit.

Caution:

When an oversize clevis is used, a pipe spacer or multispacer should be placed over clevis bolt to ensure that the lower U-strap will not move in on the bolt.



PROJECT INFORMATION	APPROVAL STAMP
Project:	Approved
Address:	Approved as noted
Contractor:	Not approved
Engineer:	Remarks:
Submittal Date:	
Notes 1:	
Notes 2:	

Adjustable Clevis Hanger (Cont.) Fig. 260 (Formerly Afcon Fig. 371)

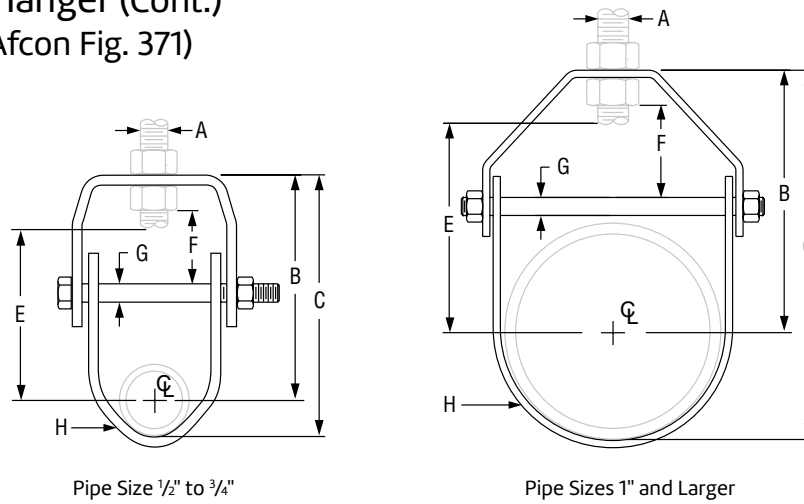

Fig. 260: Dimensions (in) • Loads (lbs) • Weight (lbs)

Pipe Size	Max Load	Span Ft.	Weight	Rod Size A	B	C	Rod Take Out E	Adjust. F	G	H Width Lower	
1/2	610	7*	0.34	3/8	2 ³ / ₁₆	2 ¹¹ / ₁₆	1 ¹ / ₂	5/8	1/4	1	
3/4			0.34		2		1 ⁵ / ₁₆				
1			0.35		3		1 ⁵ / ₈				
1 1/4	730	9*	0.40	1/2	2 ³ / ₈	3 ¹³ / ₁₆	1 ¹¹ / ₁₆	7/8	3/8	1 1/4	
1 1/2			0.45		2 ¹³ / ₁₆		2 ¹ / ₈				
2			0.50		4 ¹ / ₂		2 ⁵ / ₈				
2 1/2	1,350	11*	0.65	5/8	4 ¹ / ₁₆	5 ¹ / ₂	3 ³ / ₁₆	1 ⁵ / ₁₆	3/8	1 1/4	
3			0.85		6 ¹ / ₂		4 ¹ / ₁₆				
3 1/2			1.10		7 ¹ / ₁₆		4 ³ / ₁₆				
4	1,430	13*	1.51	3/4	5 ¹ / ₁₆	7 ¹³ / ₁₆	4 ¹ / ₂	1 ¹¹ / ₁₆	3/8	1 3/16	
5			1.70		6 ⁹ / ₁₆		5 ¹ / ₂				
6			3.10		10 ¹ / ₄		5 ³ / ₄				
8	2,000	17*	4.75	7/8	8 ³ / ₈	12 ¹¹ / ₁₆	7 ³ / ₁₆	2	1/2	1 1/16	
10			8.60		9 ⁷ / ₈		15 ¹ / ₄				8 ⁷ / ₁₆
12			11.20		11 ⁹ / ₁₆		17 ¹⁵ / ₁₆				10 ¹ / ₈
14	4,200	22*	12.50	1	12 ⁹ / ₁₆	19 ⁹ / ₁₆	10 ¹¹ / ₁₆	2 ¹¹ / ₁₆	3/4	2	
16			19.85		14		22				12
18			22.25		15 ¹⁵ / ₁₆		24 ¹⁵ / ₁₆				13 ¹⁵ / ₁₆
20	4,800	25*	40.33	1 1/4	17 ⁹ / ₁₆	27 ⁹ / ₁₆	15 ³ / ₁₆	3 ⁷ / ₈	1 1/4	3	
24**			49.83		19 ¹³ / ₁₆		31 ¹³ / ₁₆				17 ⁵ / ₁₆
30***			70.18		24 ³ / ₁₆		39 ³ / ₁₆				21 ⁹ / ₁₆

"Span" represents the maximum recommended distance between hangers on a continuous and straight run of horizontal standard weight steel pipe filled with water. In all cases, verify that chosen location of hangers does not subject hangers to a load greater than the maximum recommended load shown above.

*Indicates that span represents the maximum span for water filled pipe.

**The 24" pipe size assembly includes a 1 1/4" SCH 40 pipe spacer over the 7/8" threaded rod.

***The 30" pipe size assembly includes a 1 1/4" SCH 40 pipe spacer over the 1 1/4" threaded rod. When assembled, the U-strap sits outside of the yoke.

Universal C-type Clamp (Wide Throat) Fig. 93 (Formerly Afcon Fig. 105)

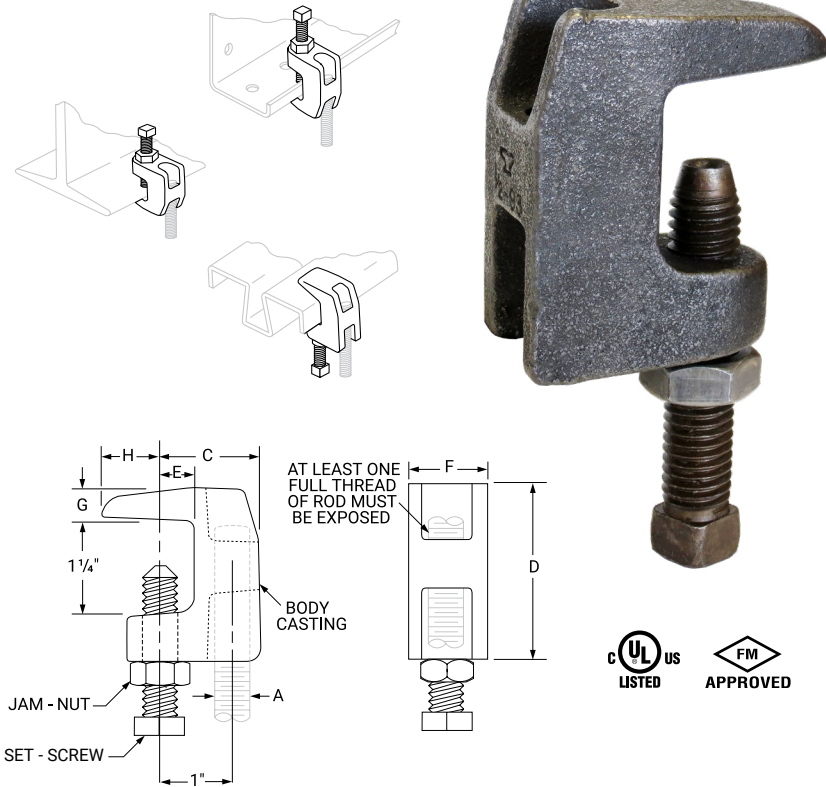

Material Specifications

Size Range
3/8" and 1/2"

Material
Ductile iron, hardened steel cup point set screw and locknut.

Finish
Plain
Zinc Plated (Hot-Dip Galvanized optional)

Service
Recommended for use under roof installations with bar joist type construction, or for attachment to the top or bottom flange of structural shapes where the vertical hanger rod is required to be offset from the edge of the flange and where the thickness of joist or flange does not exceed 1 1/4".

Approvals
Complies with Federal Specification A-A-1192A (Type 19 & 23), WW-H-171-E (Type 23), ANSI/MSS SP-69 and MSS SP-58 (Type 19 & 23).
UL, ULC Listed and FM Approved.

How to size
Size of clamp is determined by size of rod to be used.

Installation
Follow recommended set screw torque values per MSS-SP-69.

- Features**
- They may be attached to horizontal flanges of structural members in either the top beam or bottom beam positions.
 - Secured in place by a cup-pointed Set Screw tightened against the flange. A Jam Nut is provided for tightening the Set Screw against the Body Casting.
 - Thru tapping of the body casting permits extended adjustment of the threaded rod.
 - Wider throat for attaching to flange with up to 1 1/4" thickness.

Ordering
Specify rod size, figure number, name of clamp and finish.

Available with oversized tapped rod hole for Hot Dip Galvanized finish.

Dimensions (In) - Load (Lbs) - Torque (In-Lbs) - Weight (Lbs)

Rod Size A	Set Screw Size	Torque Value	Max Loads ■		Weight	C	D	E	F	G	H
			Top	Bottom							
3/8	3/8	60	500	250	0.41	1 5/16	2 5/32	9/16	13/16	3/8	5/8
1/2	1/2	125	950	760	0.75	1 3/8	2 11/32	1/2	1 1/16	7/16	13/16

Note:
■ Maximum temperature of 450° F



PROJECT INFORMATION	APPROVAL STAMP
Project:	Approved
Address:	Approved as noted
Contractor:	Not approved
Engineer:	Remarks:
Submittal Date:	
Notes 1:	
Notes 2:	

Channel Fig. AS 200

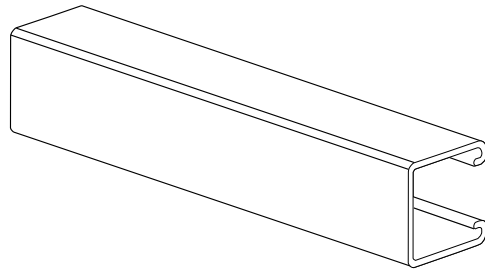

Description

Anvil-Strut channels are manufactured by a series of forming dies, or rolls, which progressively cold work the strip steel into the desired channel configuration. This method produces a cross section of uniform dimensions within a tolerance of plus or minus 0.015", on outside dimensions.

Solid AS 200

PL, GR, PG, SS, ZTC, HG

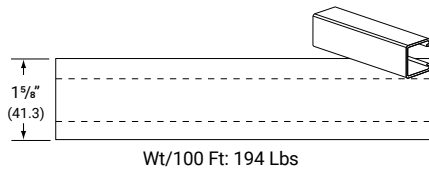

With Elongated Holes AS 200EH

PL, GR, PG, SS, ZTC, HG

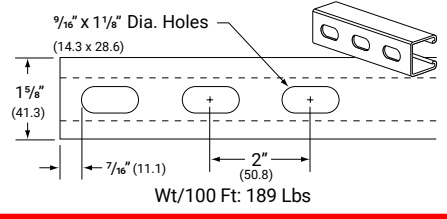

With Knock Out AS 200KO

PL, GR, PG, Other

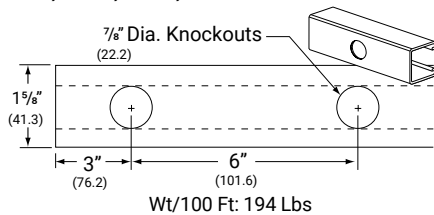

With Holes AS 200H

PL, GR, PG, Other

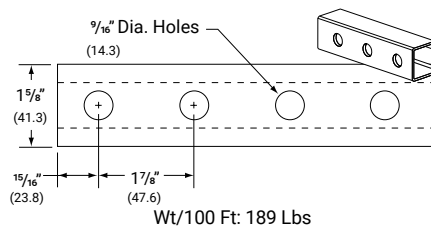

With Long Slots AS 200S

PL, GR, PG, Other

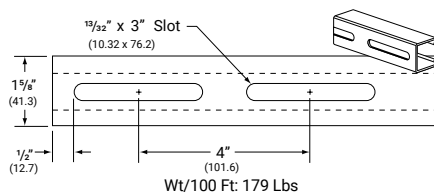

With Holes on 3 Sides AS 200H3

PL, GR, PG, Other

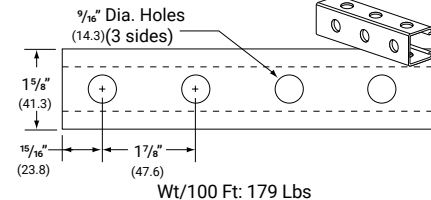

Specifications

Size:

1 5/8" X 1 5/8" (41.3 x 41.3mm)

12 Gauge Channel • wt./100 ft. - 194 lbs.

Materials:

Carbon Steel
Stainless Steel
Aluminum

Finishes

Pre-Galvanized
Hot Dip Galvanized - Post Fabrication
Supr-Green Powder Coated
Zinc Trivalent Chromium
PVC

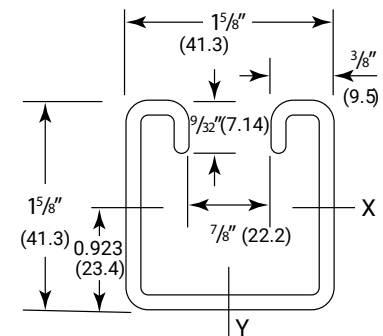

LEGEND:

GR: Powder Coated Supr-Green
EG: Electro-Galvanized
PG: Pre-Galvanized
AL: Aluminum
HG: Hot Dipped Galvanized
PL: Plain
SS: Stainless Steel
ZTC: Zinc Trivalent Chromium Stainless Steel (SS), Zinc Trivalent Chromium (ZTC) and Hot Dipped Galvanized (HG) are specialty finishes. Pricing is located in the Specialty Strut Section of the Anvil-Strut price book.



PROJECT INFORMATION	APPROVAL STAMP
Project:	Approved
Address:	Approved as noted
Contractor:	Not approved
Engineer:	Remarks:
Submittal Date:	
Notes 1:	
Notes 2:	

Channel Fig. AS 200

1⁵/₈" X 1⁵/₈" (41.3 x 41.3mm)
 12 Gauge Channel • wt./100 ft. – 194 lbs
 Stocked in pre-galvanized, plain, powder coated
 Supr-Green, zinc trivalent chromium, and hot dipped
 galvanized, in 10 & 20 ft. lengths. Note: Also available in
 Stainless Steel 304 & 316 Alloys. Other materials, finishes
 & lengths are available upon request.

Properties of Section

Catalog Number	Wt./Ft.		Area of Selection		X-X Axis						Y-Y Axis					
	Lbs.	Kg.	Sq. In.	Sq. CM	I in ⁴	I cm ⁴	S in ³	S cm ³	r in	r cm	I in ⁴	I cm ⁴	S in ³	S cm ³	r in	r cm
AS 200	1.94	2.9	0.552	3.561	0.188	7.825	0.208	3.409	0.584	1.483	0.236	9.823	0.290	4.752	0.654	1.661

I = Moment of Inertia S = Section Modulus r = Radius of Gyration

Beam and Column Loads

Span or Unbraced Height	Static Beam Load (X-X Axis)							Column Loading Data			
	Max Allowable Uniform Load	Deflection at Uniform Load	Uniform Load at Deflection				Max. Allowable Load at Slot Face	Max. Column Load Applied at C.G.			
			Span/180 Deflection	Span/240 Deflection	Span/360 Deflection	Weight of Channel		k=.65	k=.80	k=1.0	k=1.2
In	Lbs	In	Lbs	Lbs	Lbs	Lbs	Lbs	Lbs	Lbs	Lbs	Lbs
12	3,480	0.01	3,480	3,480	3,480	1.9	3,850	12,240	11,940	11,480	10,960
18	2,320	0.03	2,320	2,320	2,320	2.9	3,710	11,540	10,960	10,130	9,290
24	1,740	0.06	1,740	1,740	1,740	3.9	3,530	10,690	9,850	8,740	7,710
30	1,390	0.09	1,390	1,390	1,310	4.9	3,330	9,780	8,740	7,470	6,380
36	1,160	0.13	1,160	1,160	910	5.8	3,120	8,880	7,710	6,380	5,310
42	990	0.17	990	990	670	6.8	2,910	8,020	6,800	5,470	4,430
48	870	0.23	870	770	510	7.8	2,710	7,240	6,000	4,690	3,810
60	700	0.35	660	490	330	9.7	2,340	5,910	4,690	3,630	2,960
72	580	0.51	460	340	230	11.6	2,040	4,840	3,810	2,960	2,400
84	500	0.69	340	250	170	13.6	1,800	4,040	3,200	2,480	1,980
96	430	0.90	260	190	130	15.5	1,600	3,480	2,750	2,110	1,670
108	390	1.14	200	150	100	17.5	1,440	3,050	2,400	1,820	**
120	350	1.41	160	120	80	19.4	1,290	2,700	2,110	**	**
144	290	2.03	110	90	60	23.3	1,060	2,180	1,670	**	**
168	250	2.77	80	60	40	27.2	**	1,790	**	**	**
180	230	3.18	70	50	40	29.1	**	**	**	**	**
192	220	3.61	60	50	NR	31.6	**	**	**	**	**
216	190	4.57	50	40	NR	34.9	**	**	**	**	**
240	170	5.65	40	NR	NR	38.8	**	**	**	**	**

Bearing Load may limit load

** Not recommended - KL/r exceeds 200

Notes

- The beam capacities shown above include the weight of the strut beam. The beam weight must be subtracted from these capacities to arrive at the net beam capacity.
- Allowable beam loads are based on a uniformly loaded, simply supported beam. For capacities of a beam loaded at midspan at a single point, multiply the beam capacity by 50% and deflection by 80%.
- The above chart shows beam capacities for strut without holes. For strut with holes, multiply by the following:
 EH by 88%, S by 90%,
 H (3/16 holes) by 88%, KO by 82%.
- Refer to the Anvil-Strut Catalog for reduction factors for unbraced lengths.



Channel Fig. AS 200

Beam and Column Loads – Metric

Span or Unbraced Height	Static Beam Load (X-X Axis)							Column Loading Data			
	Max Allowable Uniform Load	Deflection at Uniform Load	Uniform Load at Deflection				Max. Allowable Load at Slot Face	Max. Column Load Applied at C.G.			
			Span/180 Deflection	Span/240 Deflection	Span/360 Deflection	Weight of Channel		k=.65	k=.80	k=1.0	k=1.2
mm	Kn	mm	Kn	Kn	Kn	Kg	Kn	Kn	Kn	Kn	Kn
305	15.5	0.3	15.5	15.5	15.5	0.9	17.1	54.4	53.1	51.1	48.8
457	10.3	0.8	10.3	10.3	10.3	1.3	16.5	51.3	48.8	45.1	41.3
610	7.7	1.5	7.7	7.7	7.7	1.8	15.7	47.6	43.8	38.9	34.3
762	6.2	2.3	6.2	6.2	5.8	2.2	14.8	43.5	38.9	33.2	28.4
914	5.2	3.3	5.2	5.2	4.0	2.6	13.9	39.5	34.3	28.4	23.6
1,067	4.4	4.3	4.4	4.4	3.0	3.1	12.9	35.7	30.2	24.3	19.7
1,219	3.9	5.8	3.9	3.4	2.3	3.5	12.1	32.2	26.7	20.9	16.9
1,524	3.1	8.9	2.9	2.2	1.5	4.4	10.4	26.3	20.9	16.1	13.2
1,829	2.6	13.0	2.0	1.5	1.0	5.3	9.1	21.5	16.9	13.2	10.7
2,134	2.2	17.5	1.5	1.1	0.8	6.2	8.0	18.0	14.2	11.0	8.8
2,438	1.9	22.9	1.2	0.8	0.6	7.0	7.1	15.5	12.2	9.4	7.4
2,743	1.7	29.0	0.9	0.7	0.4	7.9	6.4	13.6	10.7	8.1	**
3,048	1.6	35.8	0.7	0.5	0.4	8.8	5.7	12.0	9.4	**	**
3,658	1.3	51.6	0.5	0.4	0.3	10.6	4.7	9.7	7.4	**	**
4,267	1.1	70.4	0.4	0.3	0.2	12.3	**	8.0	**	**	**
4,572	1.0	80.8	0.3	0.2	0.2	13.2	**	**	**	**	**
4,877	1.0	91.7	0.3	0.2	**	14.1	**	**	**	**	**
5,486	0.8	116.1	0.2	0.2	**	15.8	**	**	**	**	**
6,096	0.8	143.5	0.2	**	**	17.6	**	**	**	**	**

Channel Fig. AS 200

Materials

Carbon Steel: Channels are formed from high-quality, structural grade carbon steel which has been manufactured in accordance with ASTM A-1011-04- SS Grade 33 (hot rolled), or ASTM 366 (cold rolled), with mechanical properties of 33 ksi minimum yield and 52 ksi minimum tensile strength. The precision roll-forming process by which the channels are formed “cold works” the steel, thereby increasing its mechanical properties.

Stainless Steel: Channels are formed from chromium-nickel stainless steel sheet manufactured in accordance with ASTM A-240 specification, offered in both AISI Type 304 and 316 material to provide protection in varying corrosive conditions.

Aluminum: Extruded aluminum channel is produced from 6063-T6 alloy, and fittings are produced from 5052-H32 alloy, both in accordance with ASTM B-221 specifications. Aluminum is suitable for use in various corrosive environments.

Finishes

Pre-Galvanized: Hot dip, mill galvanized coating produced through a process of continuously passing the steel through a bath of molten zinc. This process is performed in accordance with ASTM A-653. The thickness of the zinc coating conforms with ASTM G-90 which represents a coating thickness of .90 ounces of zinc per square foot. This coating is applied to the steel master coils prior to slitting and fabrication.

Hot Dip Galvanized - Post Fabrication: The finished channel is completely immersed in a bath of molten zinc, resulting in the complete coating of all surfaces of the product, including edges and welds. Strut channels that are hot dip galvanized, have a total coating weight of 3.0 ounces of zinc per square foot in accordance with ASTM A-123 specification. This coating provides superior results in applications calling for prolonged outdoor exposure.

Supr-Green Powder Coating: Strut channels are coated after fabrication with polyester powder finish. This coating is applied using an electrostatic spray process, beginning with cleaning and phosphating, through a bonderite pretreatment process, and ending with oven curing. The resulting finish provides a high quality appearance and durability. Powder Coating is in accordance with ASTM B-117 (standard practice for operating salt spray (fog) apparatus) to 500 hours with less than 1/8” scribe creep.

Zinc Trivalent Chromium: The finished channel undergoes a multi-step process consisting of electrogalvanizing, in accordance with ASTM B-633-85, followed by an application of zinc trivalent chromium, which provides the distinctive gold coloration of the finish. All surfaces are coated because the process is performed after fabrication.

PVC: A corrosive resistant PVC (polyvinyl chloride) coating is applied over the completed strut channel. The coating process consists of surface pretreatment, followed by preheating of the part, which is then passed through a fluidized bed of vinyl plastic powder. The powder melts onto the heated channel forming a smooth coating which undergoes a final heat curing.

Cushion Clamp Assembly Figs. AS 0040D through AS 106P



Specifications

Materials:

Clamp: 1008-1018 Carbon Steel
Cushion: High Strength TPE
Locknut: Nylon Insert

Service Temperature:

-65°F to 275°F

Approvals:

UL 2043 Fire Test for Heat and Visible Smoke Release
25/50 Flame Spread/Smoke Development Index

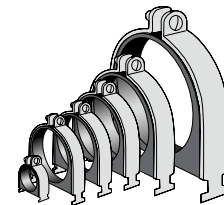

Description

Anvil-Strut Pipe Clamps are all manufactured to fit into the standard openings of 1⁵/₈" channel to support runs of piping where desired, to secure the pipe in place.

AS 0040D Thru AS 106P EG, 304SS, 316SS, ZTC

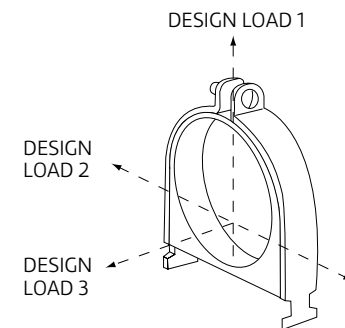
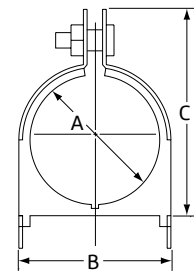

LEGEND:

GR: Powder Coated Supr-Green **EG:** Electro-Galvanized **PG:** Pre-Galvanized **AL:** Aluminum
HG: Hot Dipped Galvanized **PL:** Plain SS: Stainless Steel
ZTC: Zinc Trivalent Chromium Stainless Steel (**SS**), Zinc Trivalent Chromium (**ZTC**) and Hot Dipped Galvanized (**HG**) are specialty finishes. Pricing is located in the Specialty Strut Section of the Anvil-Strut price book.



PROJECT INFORMATION	APPROVAL STAMP
Project:	Approved
Address:	Approved as noted
Contractor:	Not approved
Engineer:	Remarks:
Submittal Date:	
Notes 1:	
Notes 2:	

Cushion Clamp Assembly Figs. AS 004OD through AS 106P

Tube Series

Part Number	O.D. Size	A	B	C	Std Pkg	Wt/100 pcs
AS 004OD	1/4"	0.25	0.62	0.98	25	10
AS 006ODN	3/8"	0.37	0.82	1.13	25	11
AS 008ODN	1/2"	0.50	0.94	1.34	25	13
AS 010ODN	5/8"	0.62	1.06	1.54	25	14
AS 012ODN	3/4"	0.75	1.20	1.68	25	14
AS 014ODN	7/8"	0.87	1.31	1.82	25	15
AS 016OD	1"	1.00	1.44	1.95	25	17
AS 018ODN	1 1/8"	1.12	1.57	2.08	20	18
AS 020OD	1 1/4"	1.25	1.70	2.21	20	18
AS 022ODN	1 3/8"	1.37	1.82	2.34	20	20
AS 024OD	1 1/2"	1.50	1.95	2.47	20	33
AS 026ODN	1 5/8"	1.62	2.07	2.60	20	35
AS 028OD	1 3/4"	1.75	2.20	2.73	20	37
AS 032OD	2"	2.00	2.45	3.04	10	41
AS 034OD	2 1/8"	2.12	2.57	3.23	10	46
AS 040OD	2 1/2"	2.50	2.94	3.79	10	49
AS 042OD	2 5/8"	2.62	3.07	3.92	5	51
AS 048OD	3"	3.00	3.57	4.42	5	57
AS 050OD	3 1/8"	3.12	3.57	4.42	5	60
AS 058OD	3 5/8"	3.62	4.20	5.11	5	70
AS 066OD	4 1/8"	4.12	4.57	5.54	5	94
AS 082OD	5 1/8"	5.12	5.57	6.54	5	125
AS 098OD	6 1/8"	6.12	6.57	7.54	5	130

Std Pkg & Wt/100 pcs: See charts above.

Specifications

Materials:

Clamp: 1008-1018 Carbon Steel

Cushion: High Strength TPE

Locknut: Nylon Insert

Service Temperature:

-65°F to 275°F

Approvals:

UL 2043 Fire Test for Heat and

Visible Smoke Release

25/50 Flame Spread/Smoke Development Index

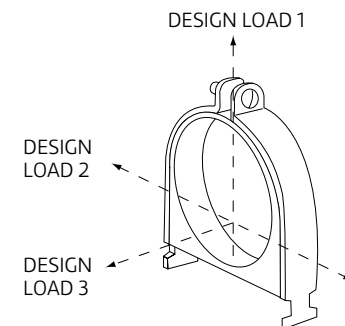
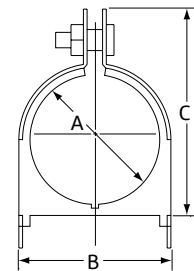
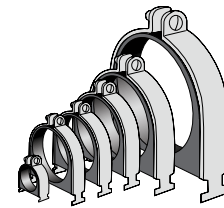

Cushion Clamp Assembly Figs. AS 004OD through AS 106P

Tube Series

Copper & Steel Tube O.D. Size	Design Load 1 (lbs)	Design Load 2 (lbs)	Design Load 3 (lbs)
1/4"	400	50	50
3/8"	400	50	50
1/2"	400	50	50
5/8"	400	50	50
3/4"	600	75	75
7/8"	600	75	75
1"	600	75	75
1 1/8"	600	75	75
1 1/4"	600	75	75
1 3/8"	600	75	75
1 1/2"	600	75	75
1 5/8"	600	75	75
1 3/4"	800	125	125
1 7/8"	800	125	125
2"	800	125	125
2 1/8"	800	125	125
2 1/4"	800	125	125
2 3/8"	800	125	125
2 1/2"	800	125	125
2 5/8"	800	125	125
3"	800	125	125
3 1/8"	800	125	125
3 5/8"	1000	200	150
4 1/8"	1000	200	150
6 1/8"	1000	200	150

Std Pkg & Wt/100 pcs: See charts above.

Specifications

Materials:

Clamp: 1008-1018 Carbon Steel

Cushion: High Strength TPE

Locknut: Nylon Insert

Service Temperature:

-65°F to 275°F

Approvals:

UL 2043 Fire Test for Heat and

Visible Smoke Release

25/50 Flame Spread/Smoke Development Index

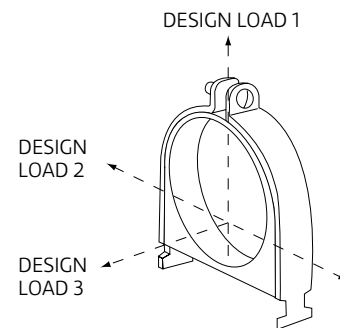
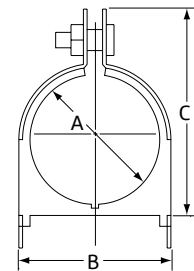
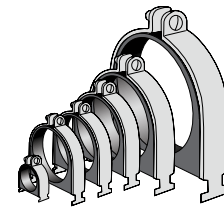

Cushion Clamp Assembly Figs. AS 004OD through AS 106P

Pipe Series

Part Number	O.D. Size	A	B	C	Std Pkg	Wt/100 pcs
AS 009P	1/4" Pipe	0.54	0.98	1.34	25	13
AS 011P	3/8" Pipe	0.67	1.13	1.54	25	14
AS 014P	1/2" Pipe	0.84	1.29	1.82	25	15
AS 017P	3/4" Pipe	1.05	1.50	2.08	20	17
AS 021P	1" Pipe	1.31	1.76	2.34	20	19
AS 027P	1 1/4" Pipe	1.66	2.17	2.73	20	35
AS 030ODP	1 1/2" Pipe	1.90	2.35	2.86	20	39
AS 038ODP	2" Pipe	2.37	2.82	3.67	10	47
AS 046ODP	2 1/2" Pipe	2.87	3.32	4.17	5	55
AS 056ODP	3" Pipe	3.50	3.95	4.79	5	55
AS 064ODP	3 1/2" Pipe	4.00	4.45	5.42	5	88
AS 072ODP	4" Pipe	4.50	4.95	5.92	5	110
AS 089P	5" Pipe	5.56	6.01	6.92	5	130
AS 106P	6" Pipe	6.62	7.07	8.23	5	140

Pipe Series

Pipe Sizes (Nominal)	Design Load 1 (lbs)	Design Load 2 (lbs)	Design Load 3 (lbs)
1/4"	400	50	50
3/8"	600	75	75
1/2"	600	75	75
3/4"	600	75	75
1"	600	75	75
1 1/4"	800	125	125
1 1/2"	800	125	125
2"	800	125	125
2 1/2"	800	125	125
3"	1000	200	150
3 1/2"	1000	200	150
4"	1000	200	150
5"	1000	200	150
6"	1000	200	150

Std Pkg & Wt/100 pcs: See charts above.

Specifications

Materials:

Clamp: 1008-1018 Carbon Steel
Cushion: High Strength TPE
Locknut: Nylon Insert

Service Temperature:

-65°F to 275°F

Approvals:

UL 2043 Fire Test for Heat and Visible Smoke Release
25/50 Flame Spread/Smoke Development Index

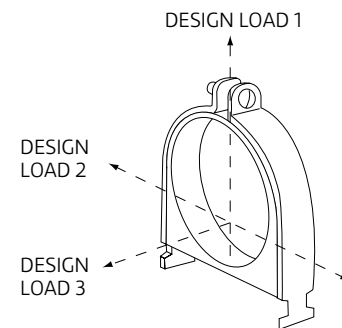
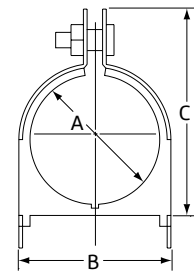
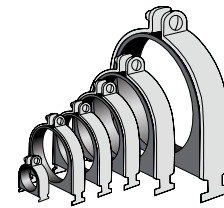

Continuous Threaded Rod Fig. 146 (Formerly Afcon Fig. 650)

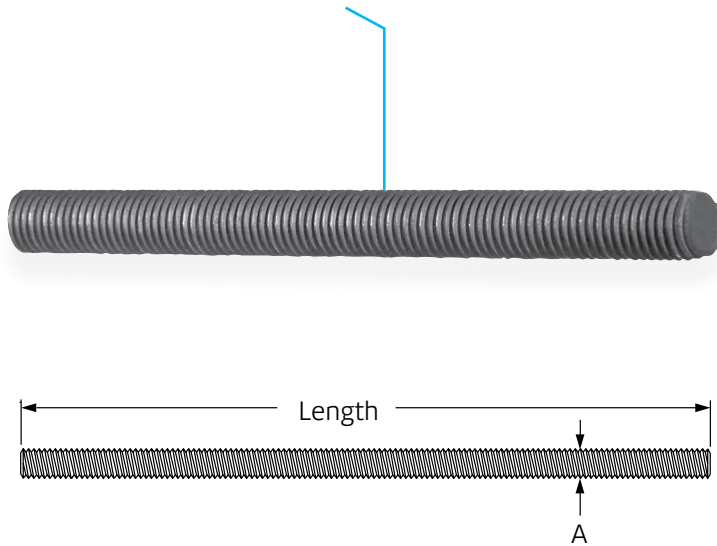

Size Range: ¼" through 1½" stocked in six, ten, and twelve foot lengths. Other even foot lengths can be furnished to order.

Material: Carbon steel or Stainless Steel Gr 304

Threads: National Coarse (USS), rod threaded complete length.

Finish: Plain or Zinc Plated (Hot-Dip Galvanized optional)

Maximum Temperature: Zinc Plated 450°F, Stainless Steel 650°F

Approvals: Complies with MSS SP-58.

Ordering: Specify rod diameter and length, figure number, name and finish.

Note: The acceptability of galvanized coatings at temperatures above 450°F is at the discretion of the end user.

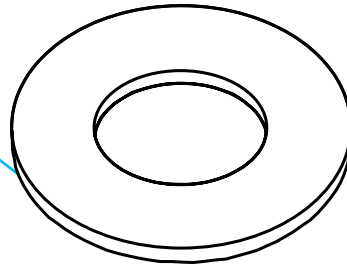

Fig. 146: Dimensions (in) • Loads (lbs) • Weight (lbs)

Rod Size A	Threads per Inch	Max Load		Weight per Ft.
		650° F		
¼	20	240		0.12
⅜	16	730		0.30
½	13	1,350		0.53
⅝	11	2,160		0.84
¾	10	3,230		1.20
⅞	9	4,480		1.70
1	8	5,900		2.30
1¼	7	9,500		3.60
1½	6	13,800		5.10

PROJECT INFORMATION	APPROVAL STAMP
Project:	Approved
Address:	Approved as noted
Contractor:	Not approved
Engineer:	Remarks:
Submittal Date:	
Notes 1:	
Notes 2:	

Flat Washer
Figs. AS 209, AS 3500,
AS 211, AS 83, AS 209,
AS 6108, AS 230



Description

Anvil-Strut Hardware, when used in conjunction with Anvil-Strut Channel and Nuts, provides a superior grip between channels and fittings.

Seismic Rod Stiffener

AS 3500 EG, ZTC

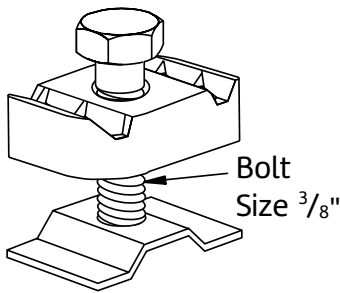

Size	Wt./100 Pcs.
3/8" - 5/8"	16

Std Pkg: 25 - Wt/100 pcs: See chart above.

Lock Washer

AS 211 EG

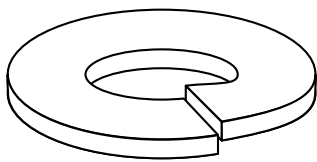

Size	Wt./100 Pcs.
1/4"	0.3
3/8"	0.7
1/2"	1.5

Std Pkg: 100 - Wt/100 pcs: See chart above.

LEGEND:

GR: Powder Coated Supr-Green **EG:** Electro-Galvanized **PG:** Pre-Galvanized **AL:** Aluminum
HG: Hot Dipped Galvanized **PL:** Plain **SS:** Stainless Steel
ZTC: Zinc Trivalent Chromium Stainless Steel (**SS**), Zinc Trivalent Chromium (**ZTC**) and Hot Dipped Galvanized (**HG**) are specialty finishes. Pricing is located in the Specialty Strut Section of the Anvil-Strut price book.



PROJECT INFORMATION	APPROVAL STAMP
Project:	Approved
Address:	Approved as noted
Contractor:	Not approved
Engineer:	Remarks:
Submittal Date:	
Notes 1:	
Notes 2:	

Flat Washer

Figs. AS 209, AS 3500, AS 211, AS 83, AS 209, AS 6108, AS 230

Hexagon Nut

AS 83 EG

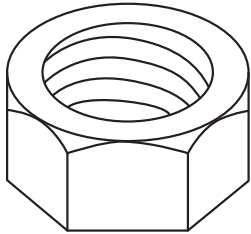

Size	Std. Pkg.	Wt./100 Pcs.
1/4"	500	0.6
3/8"	500	1.6
1/2"	100	4.8
5/8"	50	7.0
3/4"	50	12.0

Std Pkg & Wt/100 pcs: See chart above.

Flat Washer

AS 209 EG

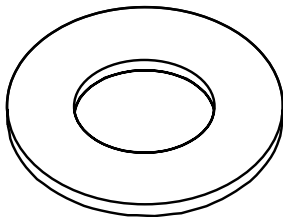

Size	Std. Pkg.	Wt./100 Pcs.
1/4"	200	0.7
3/8"	100	1.5
1/2"	100	3.5
5/8"	100	8.0
3/4"	100	11.0

Std Pkg & Wt/100 pcs: See chart above.

Square Nut

AS 6108 EG

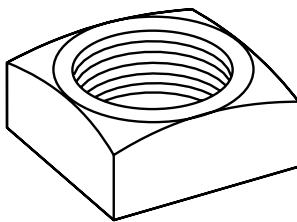

Size	Std. Pkg.	Wt./100 Pcs.
1/4"	100	0.9
5/16"	100	1.6
3/8"	100	2.7
1/2"	100	5.8

Std Pkg & Wt/100 pcs: See chart above.

Square Nut

AS 230 EG

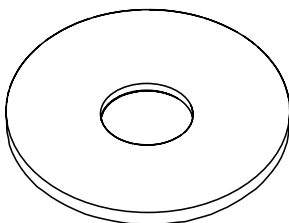

Size	Std. Pkg.	Wt./100 Pcs.
1/4"	100	3.3
3/8"	100	3.0
1/2"	100	2.8

Std Pkg & Wt/100 pcs: See chart above.

LEGEND:

GR: Powder Coated Supr-Green **EG:** Electro-Galvanized **PG:** Pre-Galvanized **AL:** Aluminum
HG: Hot Dipped Galvanized **PL:** Plain **SS:** Stainless Steel
ZTC: Zinc Trivalent Chromium Stainless Steel (**SS**), Zinc Trivalent Chromium (**ZTC**) and Hot Dipped Galvanized (**HG**) are specialty finishes. Pricing is located in the Specialty Strut Section of the Anvil-Strut price book.

3.3.12 HDI+, HDI-L+, AND HDI DROP IN ANCHORS

PRODUCT DESCRIPTION

HDI+, HDI-L+, and HDI Drop-in anchors

Anchor System	Features and Benefits
	<ul style="list-style-type: none"> Anchor, setting tool and Hilti drill bit form a matched tolerance system to provide reliable fastenings Allows shallow embedment without sacrificing performance Lip allows accurate flush surface setting, independent of hole depth for the HDI-L+ Ideal for repetitive fastenings with threaded rods of equal length
	<ul style="list-style-type: none"> HDI+ and HDI-L+ have an innovative stepped plug that reduces number of hammer blows by up to 50% HDI+ and HDI-L+ can be installed with the new HDI+ Setting Tool system (stop drill bit and machine setting tool) for improved productivity

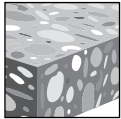

Uncracked concrete



Fire sprinkler listings

Approvals/Listings	
FM (Factory Mutual)	Pipe hanger components for automatic sprinkler systems HDI+ 3/8, HDI-L+ 3/8, HDI+1/2, HDI-L+ 1/2, HDI 5/8 and HDI 3/4
UL and cUL (Underwriters Laboratory)	Pipe hanger equipment for fire protection services HDI+ 3/8, HDI-L+ 3/8, HDI+1/2, HDI-L+ 1/2, HDI 5/8 and HDI 3/4



INSTALLATION PARAMETERS

Table 1 - Hilti HDI+, HDI-L+ and HDI specifications¹

Setting Information	Symbol	Units	HDI+ and HDI-L+			HDI	
			1/4	3/8	1/2	5/8	3/4
Insert thread	d	UNC	1/4-20	3/8-16	1/2-13	5/8-11	3/4-10
Nominal bit diameter	d _{bit}	in.	3/8	1/2	5/8	27/32	1
Nominal embedment	h _{nom}	in.	1	1-9/16	2	2-9/16	3-3/16
Anchor length	ℓ	(mm)	(25)	(40)	(51)	(65)	(81)
Hole depth	h _o						
Useable thread length	ℓ _{th}	in. (mm)	7/16 (11)	5/8 (15)	11/16 (17)	7/8 (22)	1-3/8 (34)
Installation torque	T _{inst}	ft-lb (Nm)	4 (5)	11 (15)	22 (30)	37 (50)	80 (109)
Minimum slab thickness	h	in. (mm)	3 (76)	3-1/8 (79)	4 (102)	5-1/8 (130)	6-3/8 (162)

¹ HDI+ and HDI-L+ are available in 1/4-, 3/8- and 1/2-in. The HDI is available in 5/8- and 3/4-in.

MATERIAL SPECIFICATIONS

HDI+, HDI-L and HDI anchors are manufactured from mild carbon steel. Anchor bodies are zinc plated in accordance with ASTM B633, AC 1, Type III

HDI stainless steel anchors are manufactured from AISI Type 303 stainless steel

DESIGN DATA IN CONCRETE USING ALLOWABLE STRESS DESIGN

Table 2 - Hilti HDI+, HDI-L+ and HDI carbon steel allowable loads in concrete^{1,2}

Anchor type	Nominal anchor diameter in.	$f'_c = 2,000$				$f'_c = 4,000$				$f'_c = 6,000$			
		Tension, lb (kN)		Shear, lb (kN)		Tension, lb (kN)		Shear, lb (kN)		Tension, lb (kN)		Shear, lb (kN)	
HDI+	1/4	385	(1.7)	450	(2.0)	510	(2.3)	625	(2.8)	640	(2.8)	700	(3.1)
	3/8	635	(2.8)	965	(4.3)	920	(4.1)	1,250	(5.6)	1,260	(5.6)	1,500	(6.7)
	1/2	945	(4.2)	1,500	(6.7)	1,605	(7.1)	2,125	(9.5)	1,950	(8.7)	2,500	(11.1)
HDI+	5/8	1,875	(8.3)	2,500	(11.1)	2,920	(13.0)	3,250	(14.5)	3,715	(16.5)	3,750	(16.7)
	3/4	2,500	(11.1)	3,875	(17.2)	4,065	(18.1)	5,000	(22.2)	5,565	(24.8)	5,500	(24.5)

Table 3 - Hilti HDI+, HDI-L+ and HDI carbon steel ultimate loads in concrete¹

Anchor type	Nominal anchor diameter in.	$f'_c = 2,000$				$f'_c = 4,000$				$f'_c = 6,000$			
		Tension, lb (kN)		Shear, lb (kN)		Tension, lb (kN)		Shear, lb (kN)		Tension, lb (kN)		Shear, lb (kN)	
HDI+	1/4	1,535	(6.8)	1,800	(8.0)	2,040	(9.1)	2,500	(11.1)	2,555	(11.4)	2,800	(12.5)
	3/8	2,540	(11.3)	3,850	(17.1)	3,685	(16.4)	5,000	(22.2)	5,035	(22.4)	6,000	(26.7)
	1/2	3,780	(16.8)	6,000	(26.7)	6,425	(28.6)	8,500	(37.8)	7,810	(34.7)	10,000	(44.5)
HDI+	5/8	7,500	(33.4)	10,000	(44.5)	11,685	(52.0)	13,000	(57.8)	14,865	(66.1)	15,000	(66.7)
	3/4	10,000	(44.5)	15,500	(68.9)	16,260	(72.3)	20,000	(89.0)	22,250	(99.0)	22,000	(97.9)

- The shear tests were conducted with SAE Grade 5 bolts with minimum yield strength of 85 ksi and minimum tension strength of 120 ksi. Shear testing for the 1/4-in. models were conducted with SAE Grade 8 bolts with minimum yield strength of 120 ksi and minimum tension strength of 150 ksi in 6,000 psi concrete. High-strength bolts were used to force concrete failure modes. When using steel bolts with a lower tensile strength, steel failure must be considered.
- Allowable loads calculated with a factor of safety of 4.

Table 4 - Hilti HDI+, HDI-L+ and HDI carbon steel allowable loads in lightweight concrete and lightweight concrete poured over metal deck^{1,2,3,4}

Anchor type	Nominal anchor diameter in.	3,000 psi lightweight concrete over metal deck											
		3,000 psi lightweight concrete				Upper flute				Lower flute			
		Tension, lb (kN)		Shear, lb (kN)		Tension, lb (kN)		Shear, lb (kN)		Tension, lb (kN)		Shear, lb (kN)	
HDI+	1/4	465	(2.1)	340	(1.5)	530	(2.4)	335	(1.5)	375	(1.7)	250	(1.1)
	3/8	720	(3.2)	940	(4.2)	810	(3.6)	1,010	(4.5)	500	(2.2)	500	(2.2)
	1/2	1,035	(4.6)	1,700	(7.6)	1,035	(4.6)	1,755	(7.8)	625	(2.8)	750	(3.3)
HDI+	5/8	1,465	(6.5)	2,835	(12.6)	-	-	-	-	875	(3.9)	875	(3.9)
	3/4	2,075	(9.2)	3,680	(16.4)	-	-	-	-	1,250	(5.6)	1,000	(4.4)

- The shear tests were conducted with SAE Grade 5 bolts with minimum yield strength of 85 ksi and minimum tension strength of 120 ksi. Shear testing for the 1/4-in. models were conducted with SAE Grade 8 bolts with minimum yield strength of 120 ksi and minimum tension strength of 150 ksi in 6,000 psi concrete. High-strength bolts were used to force concrete failure modes. When using steel bolts with a lower tensile strength, steel failure must be considered.
- Minimum compressive strength of structural lightweight concrete is 3,000 psi.
- See figure 1 for typical details.
- Allowable loads calculated with a factor of safety of 4.

Table 5 - Hilti HDI stainless steel allowable loads in concrete^{1,2,3}

Nominal anchor diameter in.	Nominal anchor	$f'_c = 4,000$				$f'_c = 6,000$			
		Tension, lb (kN)		Shear, lb (kN)		Tension, lb (kN)		Shear, lb (kN)	
HDI+	1/4	480	(2.1)	600	(2.7)	740	(3.3)	600	(2.7)
	3/8	1,040	(4.6)	1,230	(5.5)	1,460	(6.5)	1,230	(5.5)
	1/2	1,840	(8.2)	2,760	(12.3)	2,410	(10.7)	2,760	(12.3)
HDI+	5/8	2,630	(11.7)	4,510	(20.1)	3,770	(16.8)	4,510	(20.1)
	3/4	3,830	(17.0)	5,580	(24.8)	5,030	(22.4)	5,580	(24.8)

Table 6 - Hilti HDI stainless steel ultimate loads in concrete^{1,2}

Nominal anchor diameter in.	Nominal anchor	$f'_c = 4,000$				$f'_c = 6,000$			
		Tension, lb (kN)		Shear, lb (kN)		Tension, lb (kN)		Shear, lb (kN)	
HDI+	1/4	1,930	(8.6)	2,400	(10.7)	2,950	(13.1)	2,400	(10.7)
	3/8	4,170	(18.5)	4,920	(21.9)	5,850	(26.0)	4,920	(21.9)
	1/2	7,350	(32.7)	11,040	(49.1)	9,630	(42.8)	11,040	(49.1)
HDI+	5/8	10,540	(46.9)	18,040	(80.2)	15,100	(67.2)	18,040	(80.2)
	3/4	15,340	(68.2)	22,320	(99.3)	20,130	(89.5)	22,320	(99.3)

- Stainless steel models available in HDI version only.
- Shear testing conducted with 18-8 stainless steel bolts.
- Allowable loads calculated with a factor of safety of 4.

Figure 1 - Installation of Hilti HDI+ and HDI drop-in anchor in the soffit of concrete over metal deck floor and roof assemblies W – deck

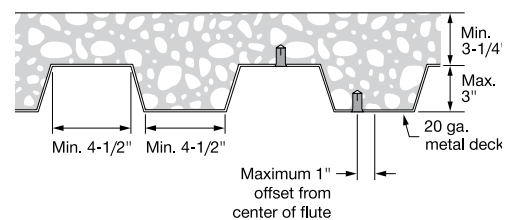

Combined shear and tension loading

$$\left(\frac{N_d}{N_{rec}} \right)^{5/3} + \left(\frac{V_d}{V_{rec}} \right)^{5/3} \leq 1.0$$

Anchor spacing and edge distance guidelines

Anchor spacing adjustment factors

- s = Actual Spacing
- $s_{min} = 2.0 h_{nom}$
- $s_{cr} = 3.5 h_{nom}$

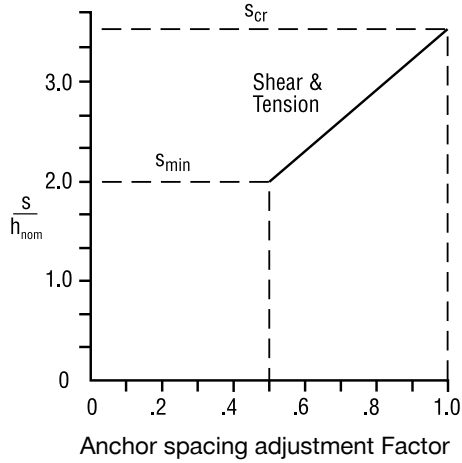

Edge distance adjustment factors

- c = Actual edge distance
- $c_{min} = 2.0 h_{nom}$
- $c_{cr} = 3.0 h_{nom}$

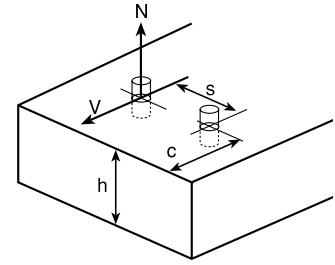
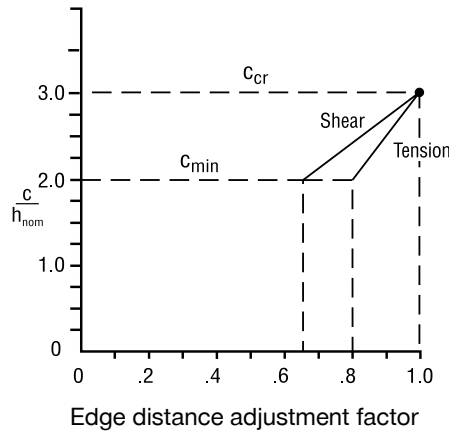

Influence of anchor spacing and edge distance f_A and f_R

Anchor Size		h_{nom}	
in.	(mm)	in.	(mm)
1/4	(6.4)	1	(25)
3/8	(9.5)	1-9/16	(40)
1/2	(12.7)	2	(51)
5/8	(15.8)	2-9/16	(65)
3/4	(19.1)	3-3/16	(81)

h_{nom} = nominal embedment depth

Table 7 - Load adjustment factors for Hilti HDI drop-in anchors in concrete

Load adjustment factors for anchor spacing f_A							Load adjustment factors for edge distance f_R											
Tension/shear loads							Tension f_{RN}						Shear f_{RV}					
Spacing s		Anchor diameter					Edge distance c		Anchor diameter				Anchor diameter					
in.	(mm)	1/4	3/8	1/2	5/8	3/4	in.	(mm)	1/4	3/8	1/2	5/8	3/4	1/4	3/8	1/2	5/8	3/4
2	(51)	.50					2	(51)	.80					.65				
2-1/2	(64)	.67					2-1/2	(64)	.90					.83				
3	(76)	.83	.50				3	(76)	1.0	.80				1.0	.65			
3-1/2	(89)	1.0	.58				3-1/2	(89)		.85					.73			
4	(102)		.69	.50			4	(102)		.91	.80				.85	.65		
4-1/2	(114)		.79	.58			4-1/2	(114)		.98	.85				.96	.74		
5	(127)		.90	.67	.50		5	(127)		1.0	.90	.80			1.0	.83	.65	
5-1/2	(140)		1.0	.75	.55		5-1/2	(140)			.95	.83				.91	.70	
6	(152)			.83	.61	.50	6	(152)			1.0	.87				1.0	.77	
7	(178)			1.0	.74	.57	6-1/2	(165)				.91	.80				.84	.65
8	(203)				.87	.67	7	(178)				.95	.84				.91	.72
9	(229)				1.0	.77	8	(203)				1.0	.90				1.0	.83
10	(254)					.88	9	(229)					.96					.94
11	(279)					.98	10	(254)					1.0					1.0
12	(305)					1.0												

$s_{min} = 2.0 h_{nom}$ $s_{cr} = 3.5 h_{nom}$ $f_A = 0.33 \frac{s}{h_{nom}} - 0.17$ for $s_{cr} > s > s_{min}$	$c_{min} = 2.0 h_{nom}$ $c_{cr} = 3.0 h_{nom}$ $f_{RN} = 0.2 \frac{c}{h_{nom}} + 0.4$ for $c_{cr} > c > c_{min}$	$c_{min} = 2.0 h_{nom}$ $c_{cr} = 3.0 h_{nom}$ $f_{RV} = 0.35 \frac{c}{h_{nom}} - 0.05$ for $c_{cr} > c > c_{min}$
---	--	--

INSTALLATION INSTRUCTIONS

Manufacturer's Printed Installation Instructions (MPII) are included with each product package. They can also be viewed or downloaded at www.hilti.com. Because of the possibility of changes, always verify that downloaded MPII are current when used. Proper installation is critical to achieve full performance. Training is available on request. Contact Hilti Technical Services for applications and conditions not addressed in the MPII.

ORDERING INFORMATION¹

HDI+, HDI-L+ and HDI

Carbon steel (Interior Use)

Description	Description	Anchor thread size	Qty / box
HDI+ 1/4	HDI-L+ 1/4	1/4	100
HDI+ 3/8	HDI-L+ 3/8	3/8	50
HDI+ 1/2	HDI-L+ 1/2	1/2	50
HDI 5/8	-	5/8	25
HDI 3/4	-	3/4	25

HDI-SS anchors

Stainless steel (Exterior Use)

Description	Anchor thread size	Qty / box
HDI 1/4 SS303	1/4	100
HDI 3/8 SS303	3/8	50
HDI 1/2 SS303	1/2	50
HDI 5/8 SS303	5/8	25
HDI 3/4 SS303	3/4	25

Setting tools for HDI and HDI-SS anchors

Description	Anchor thread size
HST 5/8 Setting Tool	5/8
HST 3/4 Setting Tool	3/4



3.3.12

Setting Tools for HDI+ and HDI-L+

Anchor thread size	Description
1/4	HST 1/4 Setting tool
	HSD-MM 1/4 (TE-C-24D6 1/4 Setting tool)
	HDI+ Setting Tool includes a TE-CX 3/8x1 carbide bit
3/8	HST 3/8 Setting tool
	HSD-MM 3/8 (TE-C-24SD10 3/8 Setting tool)
	HDI+ Setting Tool includes a TE-CX 1/2x1-9/16 carbide bit
1/2	HST 1/2 Setting tool
	HSD-MM 1/2 (TE-C-24SD12 1/2 Setting tool)
	HDI+ Setting Tool includes a TE-CX 5/8x2 carbide bit





¹ All dimensions in inches

3.3.5 KWIK BOLT TZ EXPANSION ANCHOR

PRODUCT DESCRIPTION

KWIK Bolt TZ carbon steel and stainless steel anchors

Anchor System	Features and Benefits
<div style="display: flex; justify-content: space-around;"> <div style="text-align: center;">  <p>Carbon Steel KB-TZ</p> </div> <div style="text-align: center;">  <p>Stainless Steel KB-TZ</p> </div> </div>	<ul style="list-style-type: none"> • Used with Hilti Dust Removal System (DRS) for dustless drilling and installation (compliant with Table 1 of OSHA 1926.1153 regulations for silica dust exposure). • Accurate SafeSet™ installation when using the Hilti SIW-6AT-A22 impact wrench and the SI-AT-A22 Adaptive Torque Module • Product and length identification marks facilitate quality control after installation. • Through fixture installation and variable thread lengths improve productivity and accommodate various base plate thicknesses. • Type 316 stainless steel wedges provide superior performance in cracked concrete.
<div style="text-align: center;">  <p>Hilti SIW-6AT-A22 impact wrench and the SI-AT-A22 Adaptive Torque Module</p> </div>	<ul style="list-style-type: none"> • Ridges on expansion wedges provide increased reliability. • Mechanical expansion allows immediate load application. • Raised impact section (dog point) prevents thread damage during installation. • Bolt meets ductility requirements of ACI 318-14 Section 2.3. • ACI 349-01 Nuclear Design Guide is available. Call Hilti Technical Support.

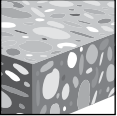

Uncracked concrete

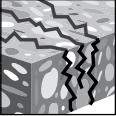

Cracked concrete

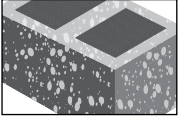

Grout-filled concrete masonry

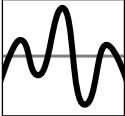

Seismic Design Categories A-F



Hollow Drill Bit with Adaptive Torque Tool (AT)



Profis Anchor design software

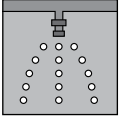

Fire sprinkler listings

Approvals/Listings	
ICC-ES (International Code Council) - 2018 International Building Code / International Residential Code (IBC/IRC) - 2015 National Building Code of Canada (NBC-C)	ESR-1917 in concrete per ACI 318-14 Ch. 17 / ACI 355.2/ ICC-ES AC193 ESR-3785 in grout-filled CMU per ICC-ES AC01 ELC-1917 in concrete per CSA A23.3-14 / ACI 355.2
City of Los Angeles	2017 LABC Supplement (within ESR-1917) RR 26057 grout-filled CMU
Florida Building Code	2010 FBC with HVHZ
FM (Factory Mutual)	Pipe hanger components for automatic sprinkler systems 3/8 through 3/4
UL and cUL (Underwriters Laboratory)	Pipe hanger equipment for fire protection services for 3/8 through 3/4



MATERIAL SPECIFICATIONS

Carbon steel with electroplated zinc

Carbon steel KB-TZ anchors have the following minimum bolt fracture loads.¹

Anchor diameter (in.)	Shear (lb)	Tension (lb)
3/8	NA	6,744
1/2	7,419	11,240
5/8	11,465	17,535
3/4	17,535	25,853

Carbon steel anchor components plated in accordance with ASTM B633 to a minimum thickness of 5 µm.

Nuts conform to the requirements of ASTM A563, Grade A, Hex.

Washers meet the requirements of ASTM F844.

Expansion sleeves (wedges) are manufactured from type 316 stainless steel

Stainless steel

Stainless steel KB-TZ anchors are made of type 304 or 316 material and have the following minimum bolt fracture loads.¹

Anchor diameter (in.)	Shear (lb)	Tension (lb)
3/8	5,058	6,519
1/2	8,543	12,364
5/8	13,938	19,109
3/4	22,481	24,729

All nuts and washers for type 304 anchors are made from type 304 stainless.

All nuts and washers for type 316 anchors are made from type 316 stainless.

Nuts meet the dimensional requirements of ASTM F594.

Washers meet the dimensional requirements of ANSI B18.22.1, Type A, plain.

Expansion sleeve (wedges) are made from type 316 stainless steel.

¹ Bolt fracture loads are determined by testing in a universal tensile machine for quality control at the manufacturing facility. These loads are not intended for design purposes. See tables 4 and 16 for the steel design strengths of carbon steel and stainless steel, respectively.

INSTALLATION PARAMETERS

Figure 1 - Hilti KWIK Bolt TZ specifications

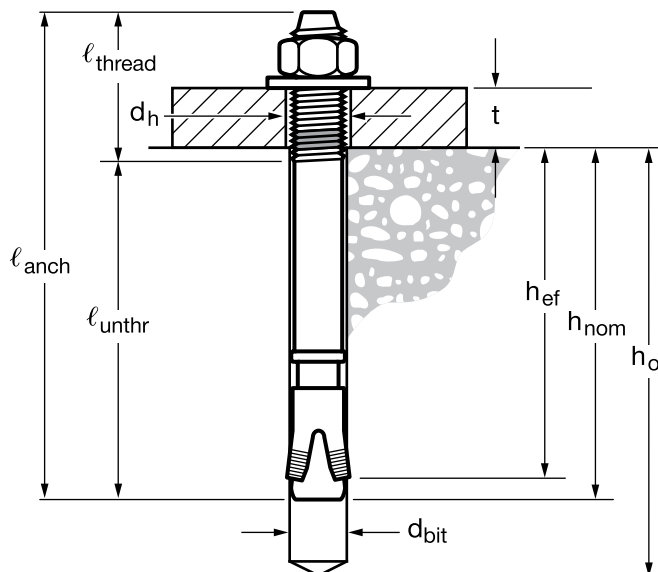

DURA-BLOK rooftop supports

BRTS-18

B-LINE
SERIES

DURA-BLOK™

A complete rooftop support solution

EATON

Powering Business Worldwide

DURA-BLOK rooftop solutions support



DURA-BLOK™ supports are made of 100% recycled rubber and are designed to provide an economical way to support pipes, HVAC systems, rooftop walkway systems, ducting, conduit, cable tray, and more.

FEATURES & BENEFITS

- Made from 100% recycled rubber
- Qualifies for LEED credits
- Reflective strip on both sides allow for easy product visibility
- Channel is through bolted on all sizes for added strength
- 1" gap between blocks allows water to flow freely around longer assemblies
- No roof penetration required
- Product composition is not sharp or abrasive; helping to extend the roof life
- Resistant to freeze/thaw
- Dampens vibration
- No need for supplemental rubber pad
- Will not float or blow away
- UV resistant
- Suitable for any type roofing material or other flat surface
- For sloped roofs see adjustable hinge fitting (B634)
- Open ends allows for easier adjustments to DBE, DBR, and DBM series
- Drainage channel through center of block

Components & accessories



CLDP10 Load Distribution Plate

Material - steel

Increases ultimate uniform load capacity on DBE & DBR Series supports to 500 lbs. (2.22kN)

UPC/Part #	Cat. #	Thickness	Width	Length	Weight Each
782051 36110	CLDP10	11 Ga. (3.0mm)	1 7/8" (41mm)	9.5" (241mm)	0.53 (0.24kg)



Loosen hex nuts and slide plate under the flat washers



Retighten the hex nuts with plate in place

Compatible components

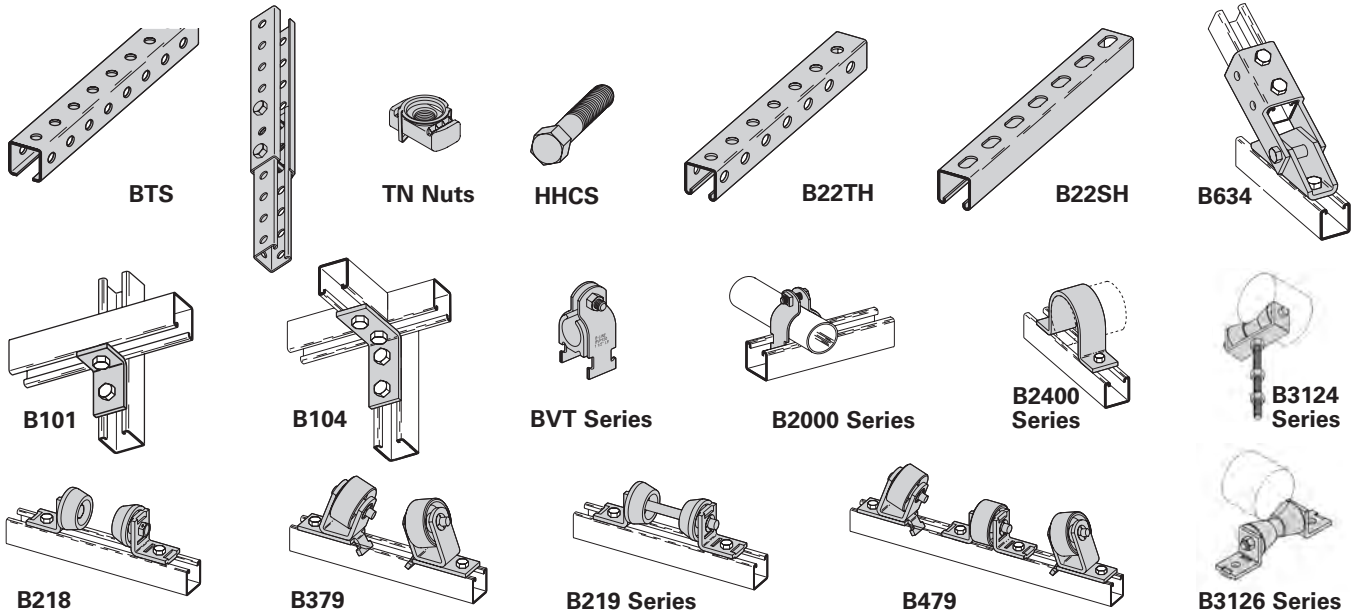

See Eaton's B-Line series Strut Systems Catalog for more information.

Rooftop applications



DB Series

Base with Galv. Channel - 1" (25mm) high

Dimensions - 5" (127mm) High x 6" (152mm) Wide x Length (overall length)

Ultimate Load Capacity - (uniform load) *

DB5 = 200 lbs. (0.89kN)
 DB10 = 500 lbs. (2.22kN)
 DB20 = 1,000 lbs. (4.45kN)

DB30 = 1,500 lbs. (6.67kN)
 DB40 = 2,000 lbs. (8.89kN)
 DB48 = 2,500 lbs. (11.12kN)

UPC/Part #	Cat. #	Height	Width	Overall Length	Weight Each
782051 50035	DB5	5" (127mm)	6" (152mm)	4.8" (122mm)	2.75 (1.25kg)
782051 49972	DB10	5" (127mm)	6" (152mm)	9.6" (244mm)	5.28 (2.39kg)
782051 49974	DB20	5" (127mm)	6" (152mm)	20.2" (513mm)	10.63 (4.82kg)
782051 50021	DB30	5" (127mm)	6" (152mm)	30.8" (782mm)	15.99 (7.25kg)
782051 50022	DB40	5" (127mm)	6" (152mm)	41.4" (1052mm)	21.34 (9.68kg)
782051 50023	DB48	5" (127mm)	6" (152mm)	52.0" (1321mm)	26.70 (12.4kg)



DB10



DB6 Series

Base with 12 ga. (2.6mm) Galv. Channel - 2 1/16" (62mm) high

Dimensions - 6 7/16" (163mm) High x 6" (152mm) Wide x Length (overall length)

Ultimate Load Capacity - (uniform load) *

DB610 = 500 lbs. (2.22kN)
 DB620 = 1,000 lbs. (4.45kN)
 DB630 = 1,500 lbs. (6.67kN)

DB640 = 2,000 lbs. (8.89kN)
 DB648 = 2,500 lbs. (11.12kN)

UPC/Part #	Cat. #	Height	Width	Overall Length	Weight Each
782051 50024	DB610	6 7/16" (163mm)	6" (152mm)	9.6" (244mm)	6.36 (2.88kg)
782051 50025	DB620	6 7/16" (163mm)	6" (152mm)	20.2" (513mm)	12.90 (5.85kg)
782051 50026	DB630	6 7/16" (163mm)	6" (152mm)	30.8" (782mm)	19.45 (8.82kg)
782051 50027	DB640	6 7/16" (163mm)	6" (152mm)	41.4" (1052mm)	26.00 (11.79kg)
782051 50028	DB648	6 7/16" (163mm)	6" (152mm)	52.0" (1321mm)	32.55 (14.76kg)



DB630



DB10 Series

Two (2) Bases with 12 ga. (2.6mm) Galv. Channel - 1 5/8" (41mm) high

Dimensions - 6 7/16" (143mm) High x 6" (152mm) Wide x Length (bridge length - see below)

Ultimate Load Capacity - 1,000 lbs. (4.45kN) (uniform load) *

UPC/Part #	Cat. #	Height	Individual Base Length	Bridge Length	Weight Each
782051 50029	DB10-28	5 5/8" (143mm)	9.6" (244mm)	28" (711mm)	2.75 (1.25kg)
782051 50031	DB10-36	5 5/8" (143mm)	9.6" (244mm)	36" (914mm)	5.28 (2.39kg)
782051 50032	DB10-42	5 5/8" (143mm)	9.6" (244mm)	42" (1067mm)	10.63 (4.82kg)
782051 50033	DB10-50	5 5/8" (143mm)	9.6" (244mm)	50" (1270mm)	15.99 (7.25kg)
782051 50034	DB10-60	5 5/8" (143mm)	9.6" (244mm)	60" (1524mm)	21.34 (9.68kg)



DB10-36

* For Roof Loading, Consult Roofing Manufacturer or Engineer. As with most commercial roofs, the weakest point may be the insulation board beneath the rubber membrane.

PART 1 GENERAL

1.01 SECTION INCLUDES

- A. The work covered by this specification consists of furnishing all labor, equipment, materials and accessories, and performing all operations required for the correct installation of recycled rubber pipe [conduit] supports for mechanical piping [electrical conduit] systems.

1.02 REFERENCES

- A. ASTM A653 G90 SS Gr. 33 - Specification for Steel Sheet, Zinc Coated (Galvanized) by the Hot Dipped Process
- B. ASTM B633 - Specification for Electrodeposited Coatings of Zinc on Iron and Steel
- C. ASTM C531 – Test Method for Linear Shrinkage and Coefficient of Thermal Expansion of Chemical Resistant Mortars, Grouts, Monolithic Surfaces, and Polymer Concretes
- D. ASTM C642 – Test Method for Specific Gravity, Absorption, and Voids in Hardened Concrete
- E. ASTM C672 – Test Methods for Scaling Resistance of Concrete Surfaces Exposed to Deicing Chemicals
- F. ASTM D412 – Test Methods for Vulcanized Rubber and Thermoplastic Elastomers – Tension
- G. ASTM D395 – Standard Test Methods for Rubber Property – Compression Set
- H. ASTM D573 – Test Method for Rubber – Deterioration in an Air Oven
- I. ASTM D746 – Test Method for Brittleness Temperature of Plastics and Elastomers by Impact
- J. ASTM D2240 – Test Method for Rubber Property – Durometer Hardness
- K. NFPA 70 – National Electrical Code

1.03 QUALITY ASSURANCE

- A. Rubber / steel pipe supports shall be manufactured under a strict quality control program assuring quality product delivered to the jobsite. Pipe supports that are damaged shall not be installed.
- B. Workmanship: All pipe [conduit] supports to be installed by a qualified piping [electrical] contractor and installed in accordance with manufacturer's recommendations.
 - 1. All work shall comply with all applicable federal, state, and local codes and laws having jurisdiction.
 - 2. All work shall conform to accepted industry and trade standards for pipe support [conduit] installations.

PART 2 PRODUCTS

2.01 ACCEPTABLE MANUFACTURERS

- A. Manufacturer: Subject to compliance with these specifications, pipe support systems shall be DURA-BLOK™ design as supplied by Eaton [or engineer approved equal].

2.02 MATERIALS

- A. Curb base must be made of 100% recycled rubber and polyurethane prepolymer with a uniform load capacity of 500 pounds per linear foot of support.* In addition, each base to have a reflective red stripe. (*See 3.01(C))
- B. Dimensions: 6-inches wide by [4] [5.0] [6.75] inches tall by [9.6] [20.2] [30.8] [41.4] [52.0] inches long.
- C. Steel frame: Steel, strut galvanized per ASTM A653 or strut galvanized per ASTM A653 for bridge series.
- D. Attaching hardware: Zinc-plated threaded rod, nuts and attaching hardware per ASTM B633.

- E. Any products claiming to be a similar, like, or equal must demonstrate (meet or exceed) the same physical and performance characteristics as specified below:

- 1. Density: 0.52 oz/cu in ASTM D575
- 2. Durometer Hardness: 67.2A ± 1 ASTM D575
- 3. Tensile Strength: 231 psi minimum ASTM D575
- 4. Compression Deformation: 5% at 70psi and 72°F ASTM D575
- 5. Brittleness at Low Temp: -50°F ASTM D746
- 6. Weathering: 70 hours at 120°F ASTM D573
 - a. Hardness retained: 100% (±5%)
 - b. Compressive strength: 100% (±5%)
 - c. Tensile strength: 100% (±5%)
 - d. Elongation retained: 100% (±5%)

2.03 TYPE OF ROOFTOP SUPPORTS

- A. Rubber block supports – DURA-BLOK™ model # [DBP] [DMB] base dimensions: 6-inch wide by 4-inch tall by [9.6] [4.8]-inch length. Accessories are fastened directly into rubber material with weather resistant type 12 lag screws.
- B. Continuous block channel supports – DURA-BLOK DB Series or DB6 Series: Dimensions 6-inch wide bt [5.0] [6.5]-inch tall bt [9.6] [20.2] [30.8] [41.4] [52.0]-inch length. Assembly has 1" gaps between blocks for free flow of water. Standard strut accessories can be used for attachment.
- C. Bridge channel supports – DURA-BLOK DB10 Series; Dimensions 6-inch wide by 5½ -inch tall by [28.0] [36.0] [42.0] [50.0] [60.0]-inch length. Standard strut accessories can be used for attachment.
- D. Extendible height support – DURA-BLOK model DBE 10-[8][12][16], height to suit application: 8-inch, 12-inch or 16-inch (200 pound maximum load). Base to be 9.6 inches in length or otherwise specified sizes available. Heavier loads, may require CLDP load distribution plate.
- E. Roller supports– DURA-BLOK DBR10 Series & DBR Series: DBR10 Series is sized for pipe up to 3½ inches, with vertical adjustment up to 12 inches. DBR Series is sized for [2-3½] [4-6] [8-10] [12-14] [16-20]-inch pipe sizes.
- F. Elevated single pipe supports– DURA-BLOK DBM Series: [Copper] or [Steel] pipe sizes [½] [¾] [1] [1¼] [1½] [2]-inch.

PART 3 EXECUTION

3.01 INSTALLATION

- A. Install in accordance with manufacturer's instructions and recommendations.
- B. If gravel top roof, gravel must be removed around and under pipe support.
- C. Always consult roofing manufacturer for roof membrane compression capacities. If necessary, a compatible sheet of roofing material (rubber pad) may be installed under rooftop support to disperse concentrated loads and add further membrane protection.
- D. Gas pipe spacing subject to local gas authorities.
- E. Use properly sized clamps to suit pipe [conduit] sizes.

For more information, visit
cooperblineline.com/dura-blok



Eaton
1000 Eaton Boulevard
Cleveland, OH 44122
United States
Eaton.com

© 2018 Eaton
All Rights Reserved
Printed in USA
Publication No. BR300001EN
June 2018 (15M) BRTS-18

B-Line Division
509 West Monroe Street
Highland, IL 62249
Eaton.com
Phone: 800-851-7415

www.cooperblineline.com/contactus

Eaton is a registered trademark.

All other trademarks are property
of their respective owners.

Follow us on social media to get the
latest product and support information.

