

Quality People. Building Solutions.

Comfort Systems USA (Arkansas), Inc.
P.O. Box 16620
Little Rock, AR 72231
Phone 501-834-3320
Fax 501-834-5416

Date: 7/20/2023

Return Request: 7/30/2023

Project: Beebe Restrooms

Supplier: Airetech

Manufacturer: Greenheck

Submittal: Ceiling Exhaust Fan

Submittal Number:

Drawing # and Installation: MP Drawings

ARCHITECT

Lewis Architects Engineers
11205 Huron Lane Suite 104
Little Rock, AR 72211
501-223-9302

ENGINEER

Lewis Architects Engineer
11205 Huron Lane Suite 104
Little Rock, AR 72211
501-223-9302

GENERAL CONTRACTOR

Nabholz
612 Garland
Conway, AR 72032
501-505-5800

MECHANICAL SUBCONTRACTOR

Comfort Systems USA (Arkansas), Inc.
9924 Landers Rd.
N. Little Rock, AR 72117
501-834-3320

Notes:

chowell@comfortar.com

9924 Landers Rd.
No. Little Rock, AR 72117

Installation, Operation and Maintenance Manuals

Job Title: Beebe School District Reno and Add

Engineer: Lewis AE

Elevation: (ft) 256

Date: 11/15/2023

Submitted By: Dustin Easterly

AIRETECH CORPORATION - 2364

7631 NORTSHORE PL

NORTH LITTLE ROCK, AR 72118

US

Phone: (501)280-0404

Fax:

Email Address: forrest@airetechcorp.com



P.O. Box 410 Schofield, WI 54476 (715) 359-6171 FAX (715) 355-2399 www.greenheck.com

Job Name: Beebe School District Reno and Add

Product IOMs

Mark Name	Model Name
EF-1,2	SP

Installation, Operation and Maintenance Manual

Please read and save these instructions for future reference. Read carefully before attempting to assemble, install, operate or maintain the product described. Protect yourself and others by observing all safety information. Failure to comply with these instructions will result in voiding of the product warranty and may result in personal injury and/or property damage.

Direct Drive Ceiling Exhaust Fan

Designed for clean air applications where low sound levels are required. Many options and accessories are available such as lights, motion detectors, ceiling radiation dampers and speed controls.



Direct Drive Inline Exhaust Fan

Designed for clean air applications where low sound levels are required.



WARNING!

To reduce the risk of fire, electric shock, or injury to persons, observe the following:

- Suitable for use with solid state speed controls.
- Use this unit only in the manner intended by the manufacturer. If you have questions, contact the manufacturer.
- Before servicing or cleaning unit, switch power off at service panel and lock service disconnecting means to prevent power from being switched on accidentally. When the service disconnecting means cannot be locked, securely fasten a prominent warning device, such as a tag, to the service panel.
- Installation work and electrical wiring must be done by qualified person(s) in accordance with all applicable codes and standards, including fire-rated construction.
- Sufficient air is needed for proper combustion and exhausting of gases through the flue (chimney) of fuel burning equipment to prevent back drafting. Follow the heating equipment manufacturer's guideline and safety standards such as those published by the National Fire Protection Association (NFPA), and the American Society for Heating, Refrigeration and Air Conditioning Engineers (ASHRAE) and the local code authorities.
- When cutting or drilling into wall or ceiling, do not damage electrical wiring or other hidden utilities.
- Select models are acceptable for use over a bathtub or shower when installed in a GFCI protected branch circuit. (Up through size SP-A390)
- Never place a switch where it can be reached from a tub or shower.
- Ducted fans must always be vented to the outdoors.
- These fans are not recommended for cooking exhaust applications. They are designed primarily for low temperature, clean air applications only. The diagram shows the minimum distance these fans should be placed in relation to cooking equipment.
- Fan/Light combination not to be installed in a ceiling thermally insulated to a value greater than R40.

CAUTION!

- For general ventilating use only. Do not use to exhaust hazardous or explosive materials and vapors.

AVERTISSEMENT!

Pour réduire le risque d'incendie, de choc électrique ou de blessure corporelle, respecter ce qui suit:

- Appareil pouvant être utilisé avec un régulateur de vitesse à semi-conducteurs.
- Utiliser cet appareil exclusivement comme prévu par le fabricant. En cas de questions, communiquer avec le fabricant à l'adresse ou au numéro de téléphone figurant dans la garantie.
- Avant tout entretien ou nettoyage de l'appareil, couper l'alimentation sur le tableau électrique et verrouiller le dispositif de sectionnement pour empêcher toute mise sous tension accidentelle. Si le dispositif de sectionnement ne peut pas être verrouillé, attacher un moyen de mise en garde bien visible, tel qu'un panneau, au tableau électrique.
- La pose et le câblage électrique doivent être effectués par des personnes qualifiées en conformité avec les codes et normes en vigueur, y compris pour la résistance au feu du bâtiment.
- Une quantité d'air suffisante est nécessaire pour la bonne combustion et l'extraction des gaz brûlés par le conduit d'évacuation (cheminée) d'appareils à combustible afin d'éviter le refoulement. Veiller à suivre les indications du fabricant du matériel de chauffe, les normes de sécurité telles que celles publiées par la National Fire Protection Association (NFPA) et l'American Society for Heating, Refrigeration and Air Conditioning Engineers (ASHRAE) et la réglementation en vigueur.
- Lors de la découpe ou du perçage de murs ou plafonds, ne pas endommager les câbles électriques et autres conduites masquées.
- Certains modèles (jusqu'au modèle SP-A390 inclus) sont approuvés pour une installation au-dessus d'une baignoire ou d'une douche sous réserve d'être raccordés à un circuit de dérivation protégé par un DDFT.
- Ne jamais placer d'interrupteur à un emplacement à portée d'une baignoire ou d'une douche.
- Les caissons d'extraction à gaine doivent toujours être évacués vers l'extérieur.
- Ces caissons ne sont pas conseillés pour les applications d'aspiration de vapeurs de cuisson. Ils sont conçus essentiellement pour l'aspiration d'air propre à basse température. Le schéma indique la distance minimale de placement de ces caissons par rapport à l'équipement de cuisson.
- Le combiné ventilateur/luminaire ne devra pas être installé dans un plafond ayant une isolation thermique d'une valeur supérieure à R40.

ATTENTION!

- À utiliser pour la ventilation générale uniquement. Ne pas utiliser pour l'aspiration de matières et vapeurs dangereuses ou explosives.

Typical Installation

The ducting from this fan to the outside of the building has a strong effect on the air flow, noise and energy use of the fan. Use the shortest, straightest duct routing possible for best performance, and avoid installing the fan with smaller ducts than recommended. Insulation around the ducts can reduce energy loss and inhibit mold growth. Fans installed with existing ducts may not achieve their rated airflow.

Rigid metal duct is recommended for optimal fan performance.

Ensure duct joints and exterior penetrations are sealed with caulk or other similar material to create an air-tight path and to minimize building heat loss and gain and reduce the potential for condensation.

Place/wrap insulation around duct and/or fan to in order to minimize possible condensation buildup within the duct, as well as minimize building heat loss and gain.

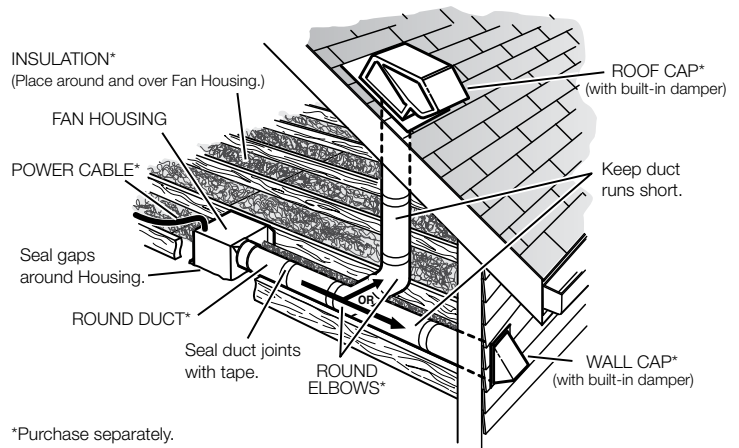

*Purchase separately.



Energy Star® Certified Fan Model/Size	Recommended Duct Dimensions
SP-A70, SP-A90, SP-A50-90-VG, SP-A90-130-VG, SP-B70, SP-B80, SP-B90	6 inch round
SP-A110, SP-A125, SP-A190	8 x 6 inch rectangular
SP-A200, SP-A250	8 x 8 inch rectangular

Other Installation Considerations

Ductwork and Noise

Fiberglass ductboard is a better choice than metal ductwork for reducing fan noise and is highly recommended for low sound applications. Where metal duct is used, sound transmission can be reduced with flexible duct connections between the fan and the duct.

Sound and Location

The location of these fans must be taken into consideration before installation. In critical sound installations, insulated ductwork, flexible duct connections or placing the fan in a remote section of ductwork are solutions to meeting the required fan sound levels.

Filters

The addition of an intake filter is highly recommended for these fans, even in clean air environments excess dirt can accumulate on wheels and motors causing reduced performance and imbalance.

Filters, once installed, should be checked and cleaned periodically to maintain performance.

Washable aluminum mesh filters specifically designed for these fans are available, please consult your representative for more information.

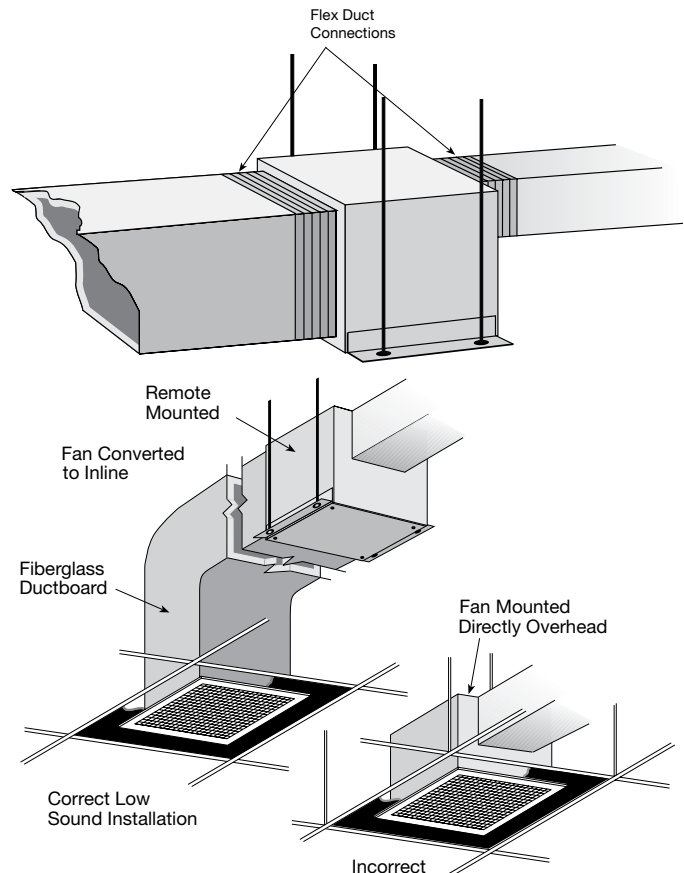

Prepare the Fan

Power Assembly

If power assembly (motor, wheel, and scroll) is not installed in housing, insert the electrical plug into fan socket, then slide scroll end of power assembly into fan housing. Attach by using two sheet metal screws provided.

A Model

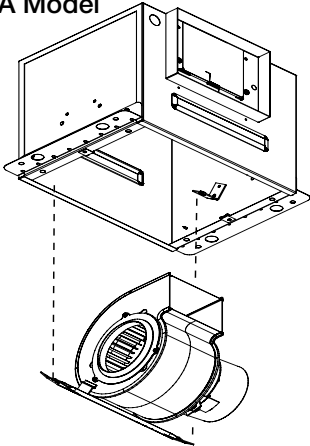

B Model

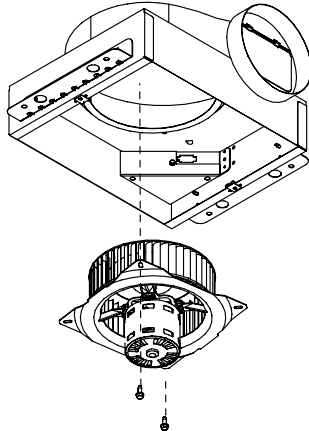

Remove Wiring Knockout

Remove either top or side wiring knockout, depending on wiring direction, by bending it back and forth to break tabs.

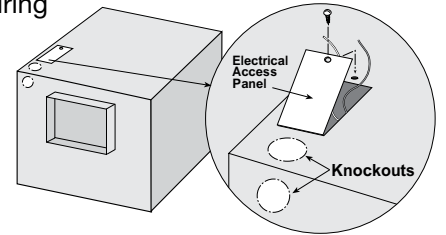

Ductwork

Check ductwork to see if the fan's discharge requires rotation from horizontal to vertical discharge.

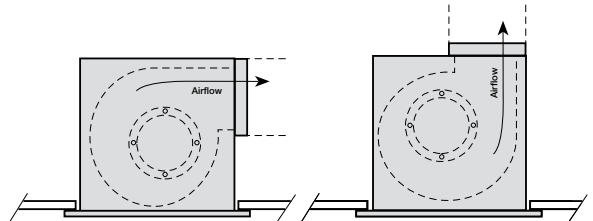

Fan Rotation

To rotate from horizontal to vertical discharge
A Models Only

A50-510, 710, 780 Models

Remove the two screws holding the power assembly in and pull power assembly out. Rotate power assembly 180 degrees and put back into fan. Use the same screws to reattach power assembly to fan housing. Flip fan over and remove the four screws holding the discharge duct and damper assembly. Exchange the assembly with plate mounted on top of fan, as shown in these illustrations.

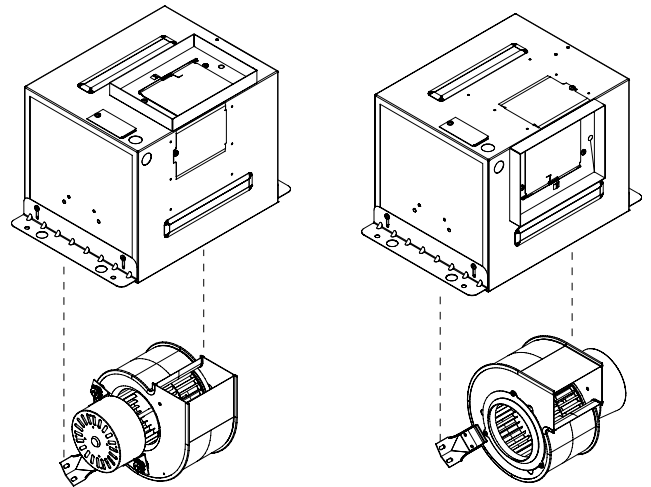

A700, 900-1500 Models

Remove the eight screws holding the access panel or collar as shown in picture. Rotate the fan housing so the discharge is facing up. Replace access panel or collar and screws.

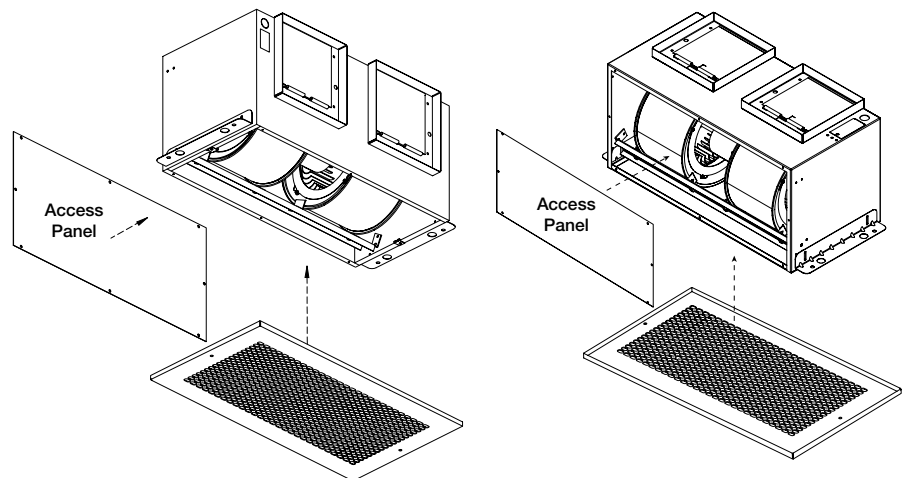

Ceiling Radiation Damper (CRD)

If fan is to be used in a fire resistive membrane ceiling, a ceiling radiation damper must be used.

If the ceiling radiation damper is already mounted to the fan from the factory, proceed to Install the Fan.

To mount the ceiling radiation damper to fan, make sure grille attachment tabs are facing down. Then place the inlet part of the fan into the ceiling radiation damper collar, and use self-tapping sheet metal screws (by others) to screw through the damper collar and into the fan housing. If the fan/light combination is being used, make sure ceiling

radiation damper has an electrical plug in it. The electrical plug must be inserted into the fan. Make sure the electrical wire will not interfere with damper operation as shown in figure below.

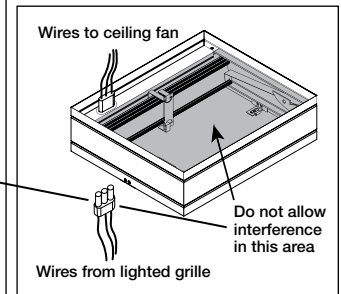
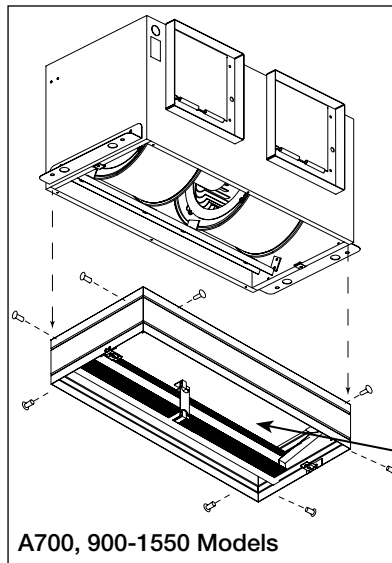
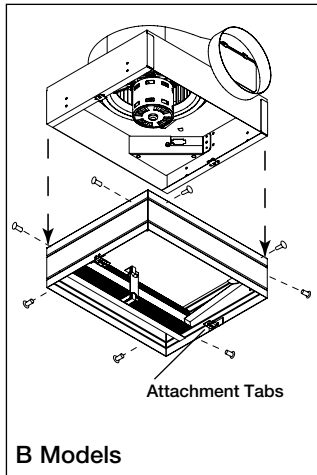
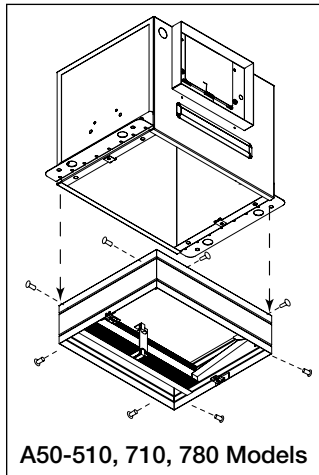

Discharge Installation A50-90 Models

1 Insert plastic duct tab into box slots.

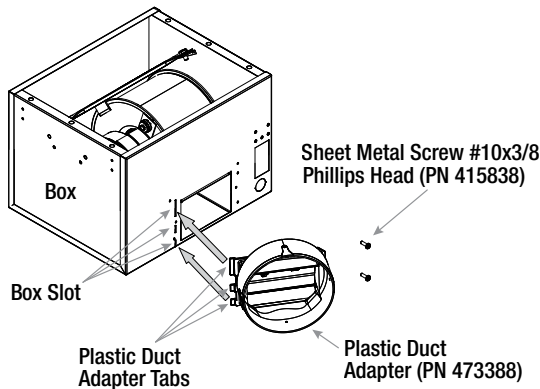

2 Rotate plastic duct adapter (PN 473388) until the screw tabs meet the box.

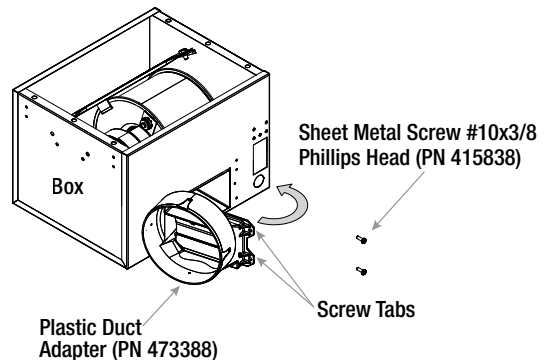

3 Install screws provided to secure discharge.

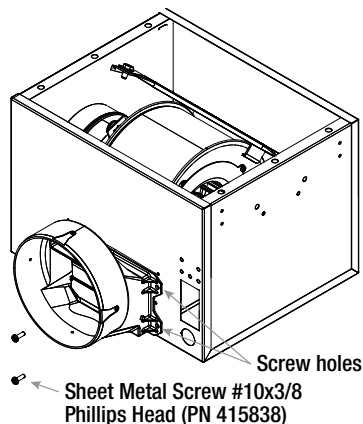

Discharge Installation for Ceiling and Inline Exhaust Models Sizes B50-200

1 Insert box scroll tab into box scroll slots.

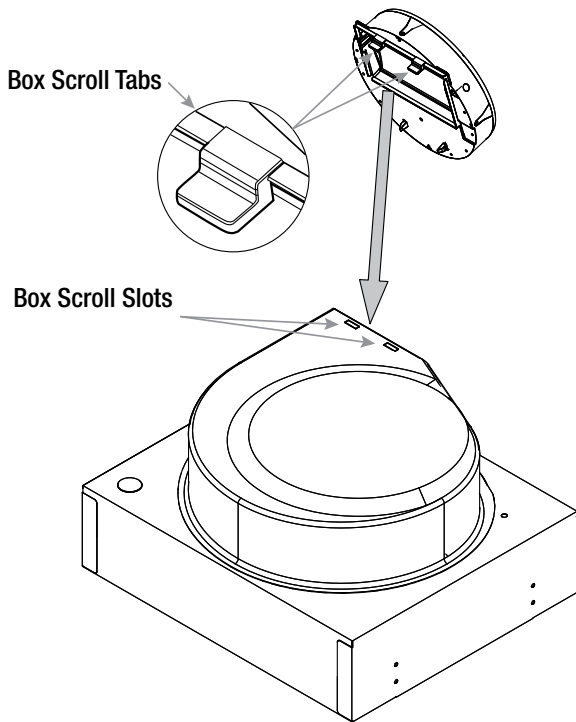

2 Rotate plastic duct adapter (PN 474433) until the two mounting tabs fully engage into the two box mounting slots.

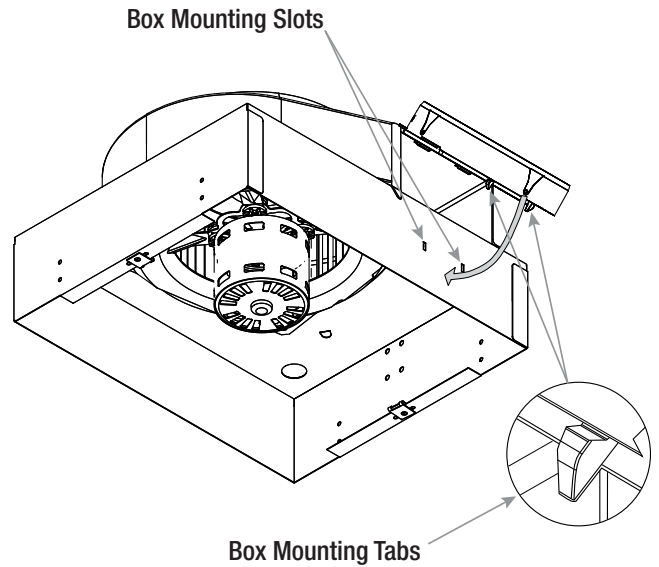

3 **OPTIONAL**
Align the pins on the TR 6x4 adaptor to the duct pin hole on the 6-inch duct. Push until the adaptor snaps into place.

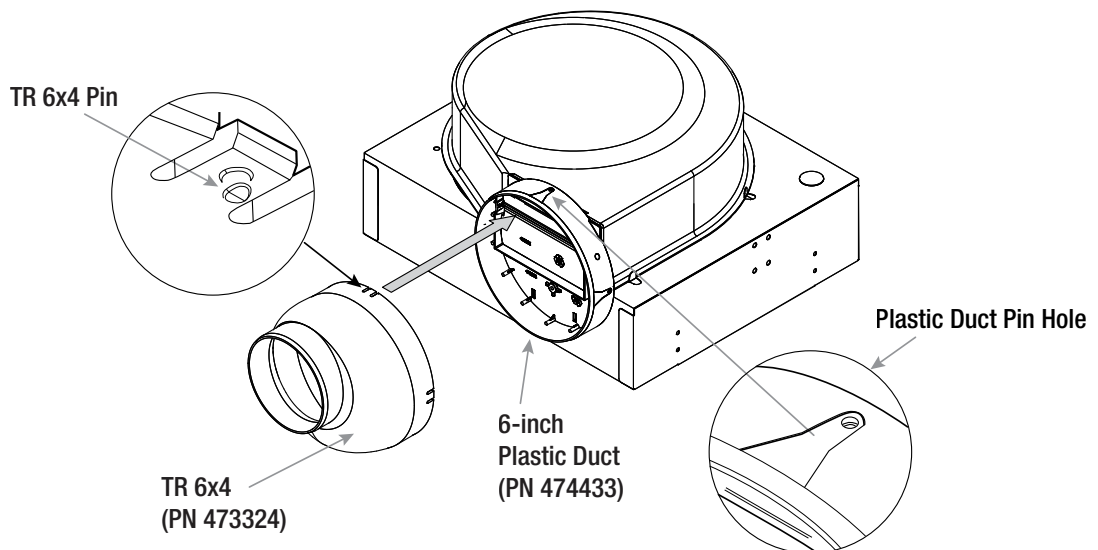

Install the Fan

- For best performance, choose a location with the shortest possible duct run and minimum number of elbows. Do not mount near cooking equipment, as shown in Fig. 1.

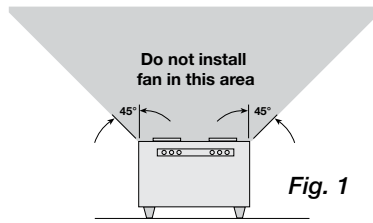

Fig. 1

- Attach adjustable mounting brackets to fan, but leave the screws loose until proper height is determined, shown in Fig. 2. Cut hole to dimensions shown in table below:

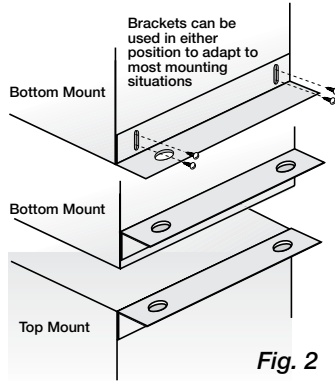

Fig. 2

Ceiling Openings		
Ceiling Exhaust Sizes	Fan or Fan/Light	Fan/CRD
A50, A70, A90, A50-90-VG, A90-130-VG, A110, A125, A190	10 ⁷ / ₈ x 13 ³ / ₈	11 ¹ / ₈ x 13 ⁷ / ₁₆
A200, A250, A290, A390	12 ¹ / ₈ x 14 ¹ / ₄	12 ¹ / ₄ x 14 ³ / ₈
A700	23 ³ / ₄ x 11 ³ / ₄	24 ¹ / ₈ x 12 ¹ / ₄
A410, A510, A510-VG, A710, A710-VG, A780	14 ³ / ₄ x 18 ³ / ₈	14 ⁷ / ₈ x 18 ⁷ / ₁₆
A900, A1050, A1410, A1550	14 ³ / ₄ x 24	14 ⁷ / ₈ x 24 ¹ / ₈
B50 - 200	14 ¹ / ₈ x 11 ³ / ₄	14 ³ / ₈ x 12 ¹ / ₄

NOTE

Model sizes A50-90 are standard with a round duct. Should any model A110-190 require a round duct, Model RDC (Round Duct Connector) may be ordered from manufacturer for field installation.

For Frame Construction:

Position unit between joists. Position brackets such that bottom edge of housing will be flush with finished ceiling, and tighten the adjustable mounting brackets, shown in Fig. 3.

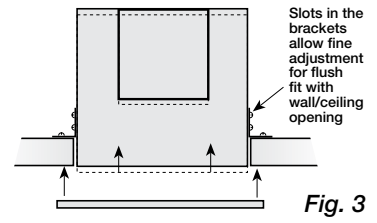

Fig. 3

For Hanging Installations:

Use manufacturer's optional vibration isolator kit Part Number VI Kit. Using the fan's standard adjustable mounting brackets and 10 by 32 threaded rod (by others), hang unit as shown in Fig. 4.

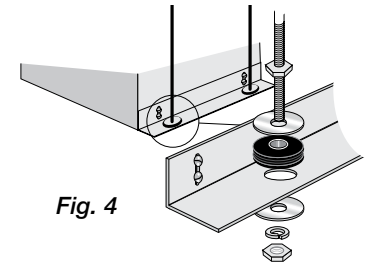

Fig. 4

- Installation of ductwork is critical to the performance of the fan, shown in Fig. 5. Straight ductwork (1) or ductwork that turns in the same direction as the wheel (2) is recommended. Ductwork turning opposite the wheel direction (3) will cause turbulence and back pressure resulting in poor performance.

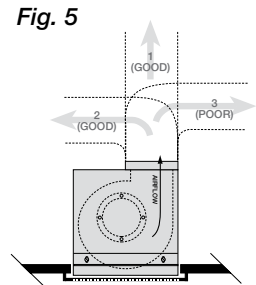

Fig. 5

- Slide ductwork over the fan's discharge collar and securely attach it with sheet metal screws.

Make sure the screws do not interfere with damper operation. Check damper to make sure it opens freely.

Wire the Fan

- Remove wiring cover. If fan/accessory combination is being used, make sure the fan plug is connected to the fan receptacle and the accessory plug is connected to the accessory receptacle, shown in Fig. 6. Using proper wire connectors, wire the fan as shown in Fig. 7a. For wiring of light proceed to Fig. 7b.

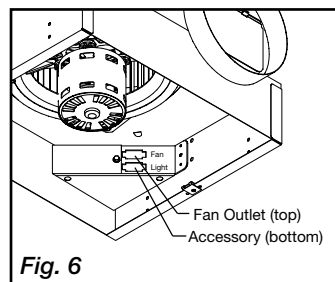

Fig. 6

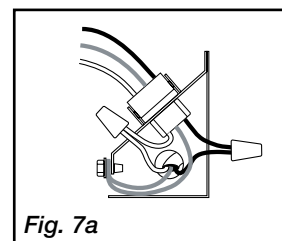

Fig. 7a

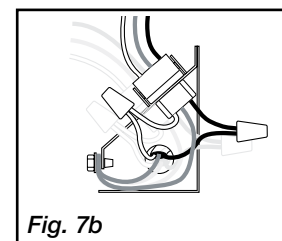

Fig. 7b

115 & 277 Volt
Black wire is "Hot"
White wire is "Neutral"
Green wire is "Ground"

220 - 240 Volt
Black wire is "Hot"
White wire is "Hot"
Green wire is "Neutral/Ground"

- Push all wiring into the unit's cover and replace wiring cover.

A50-90-VG and A90-130-VG Fan Models

These fan models utilize an internal switch to set the fan to run at one of three flows. Please set three position switch to desired airflow when installing unit.

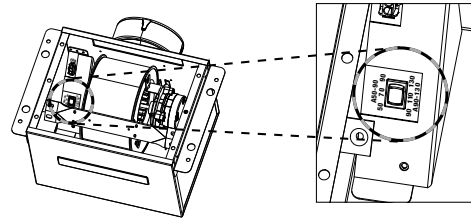

Whole House Ventilation Two-Speed Operation

A90 and 110, B50, 80 and 110 Models

1. Install fan per standard instructions.
2. Fan will operate at the certified airflow rate when wall switch or integrated sensor is activated.
3. Fan will operate at user set low speed when wall switch or integrated sensor is off.
 - a. User defined flow rate can be set by adjusting the dial pre-installed in the fan. Airflow is dependent on overall static pressure in the ductwork. Airflow will need to be verified with a measuring device.
4. When servicing fan, ensure the circuit is shut off at the breaker.

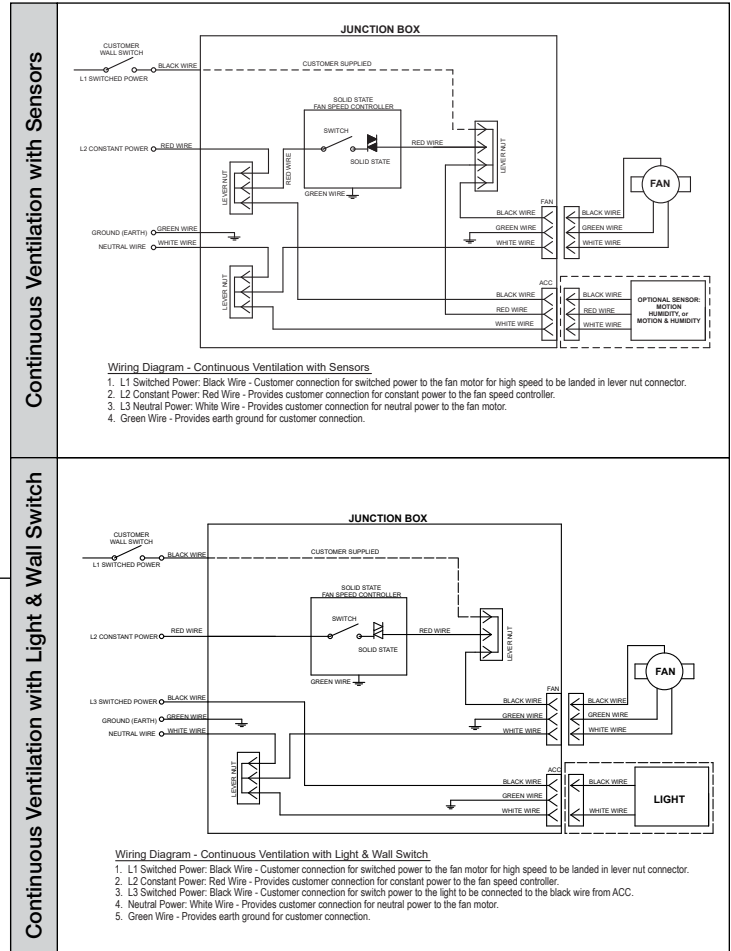
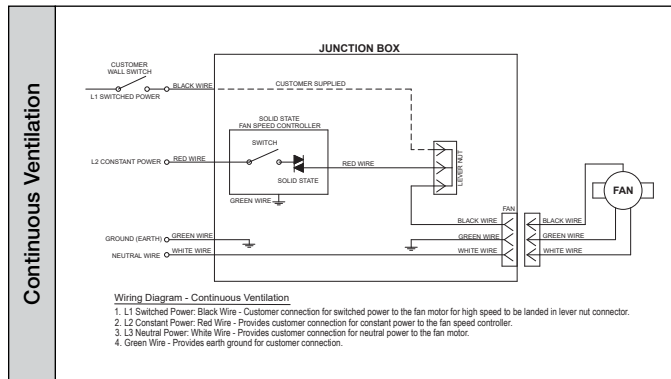

Attach the Grille

1. If lighted grille is being used, plug wire from lighted grille into accessory socket.
If lighted grille and ceiling radiation damper are being used, plug wire from lighted grille into ceiling radiation damper socket. Do not plug wire directly into the fan socket. Make sure the wire does not interfere with the ceiling radiation damper operation.
2. Attach grille with two screws provided. Make sure not to over tighten; over tightening will damage grille.
3. Slide attachment screw covers over the attachment screws, shown in Figure 8 and 9.
4. If lighted grille is being used, install light bulb(s) into light socket(s). For fluorescent lights, use 27W GU24 bulbs. For LED lights, use 10W GU24 bulbs. Manufacturer has replacement 27W GU24 bulbs, call 1-800-355-5354 to order.

5. If lighted grille is being used, snap lens into place, by pushing on the outside edges of lens, shown in Fig. 9. To remove lens, use a small screw driver and pry on one side of lens.
6. Turn on power and check fan and light operation.

Fig. 8

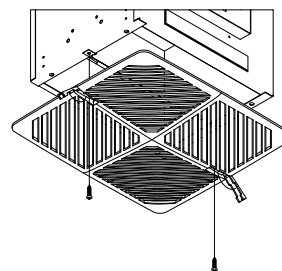
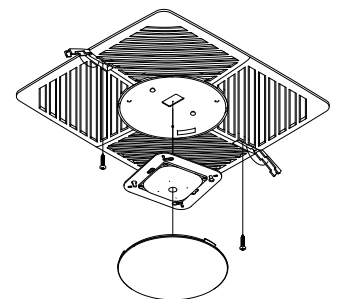
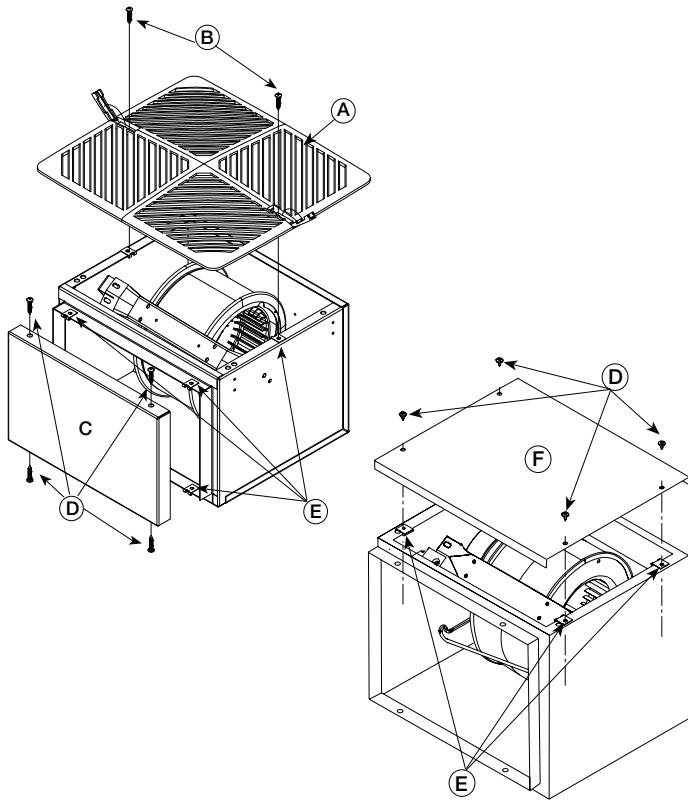

Fig. 9



Converting from Ceiling to Cabinet Design for Ceiling Exhaust Fans



All convertible sizes will be shipped with grille and duct collar cover. Note, this applies only to fans originally ordered as convertible.

Conversion Kit Parts List

- Qty. of 1 Blower Box Cover

Tools Required

- Phillips Head Screwdriver

- Step 1: Remove grille (A) by removing the two grille screws (B).
- Step 2: Remove duct collar cover (C) by removing the four duct collar screws (D).
- Step 3: Discard grille (A), two grille screws (B), and duct collar cover (C).
- Step 4: Remove the six (6) tinnerman clips (E) by twisting them to one side and pulling straight out. Discard two of the six tinnerman clips.
- Step 5: Insert the remaining four tinnerman clips (E) on grille opening side.
- Step 6: Place blower box cover (F) over tinnerman clips (E), which were inserted in step 5.
- Step 7: Screw the blower box cover (F) into place with four blower box cover screws (D).

General Maintenance Suggestions

Ceiling exhaust fans require very little maintenance, but since small problems over time left unchecked could lead to loss of performance or early motor failure, we do recommend that the unit be inspected periodically (once or twice a year).

The fan motor and wheel should be checked for dust and dirt accumulations. Dirt buildup can lead to loss of performance and motor overheating. Cleaning can be accomplished by brushing off any dust that may have accumulated. Even filtered units can accumulate build-up and should be checked when cleaning filters.

The motor should be checked for lubrication at this time. Lubricate only those motors which have an oil hole provided. A few drops of all purpose oil (SAE 20) will be sufficient.

Our Commitment

As a result of our commitment to continuous improvement, Greenheck reserves the right to change specifications without notice.

Specific Greenheck product warranties are located on greenheck.com within the product area tabs and in the Library under Warranties.

Greenheck's Centrifugal Ceiling and Cabinet Exhaust Fans catalog provides additional information describing the equipment, fan performance, available accessories, and specification data.

AMCA Publication 410-96, Safety Practices for Users and Installers of Industrial and Commercial Fans, provides additional safety information. This publication can be obtained from AMCA International, Inc. at www.amca.org.



Phone: 715.359.6171 • Fax: 715.355.2399 • Parts: 800.355.5354 • E-mail: gfcinfo@greenheck.com • Website: www.greenheck.com

Installation, Operation and Maintenance Manual

Please read and save these instructions for future reference. Read carefully before attempting to assemble, install, operate or maintain the product described. Protect yourself and others by observing all safety information. Failure to comply with these instructions will result in voiding of the product warranty and may result in personal injury and/or property damage.



Motion Sensor
Part No. 880689



**Motion + Humidity
Combination Sensor**
Part No. 880690



Humidity Sensor
Part No. 386429

General Safety Information

Only qualified personnel should install this product. Personnel should have a clear understanding of these instructions and should be aware of general safety precautions. Improper installation can result in electric shock, possible injury due to coming in contact with moving parts, as well as other potential hazards. If more information is needed, contact a licensed professional engineer before proceeding with installation.

1. Follow all local electrical and safety codes, as well as the National Electrical Code (NEC) and the National Fire Protection Agency (NFPA), where applicable. Follow the Canadian Electric Code (CEC) in Canada.
2. Motor must be securely and adequately grounded.
3. Do not allow the power cable to kink or come in contact with oil, grease, hot surfaces or chemicals. Replace cord immediately if damaged.
4. Verify that the power source is compatible with the equipment.

DANGER

Always disconnect, lock and tag power source before installing or servicing. Failure to disconnect power source can result in fire, shock or serious injury.

CAUTION

When servicing the fan, motor may be hot enough to cause pain or injury. Allow motor to cool before servicing.

CAUTION

Precaution should be taken in explosive atmospheres.

DANGER

Pour écarter les risques d'incendie, de choc électrique ou de blessure grave, veiller à toujours débrancher, verrouiller et étiqueter la source de courant avant l'installation ou l'entretien.

ATTENTION

Lors de toute intervention sur la soufflante, le moteur peut être suffisamment chaud pour provoquer une douleur voire une blessure. Laisser le moteur refroidir avant toute maintenance.

ATTENTION

Faire preuve de précaution dans les atmosphères explosives.

Receiving

Upon receiving the product, check to ensure all items are accounted for by referencing the delivery receipt or packing list. Inspect each crate or carton for shipping damage before accepting delivery. Alert the carrier of any damage detected. The customer will make notification of damage (or shortage of items) on the delivery receipt and all copies of the bill of lading which is countersigned by the delivering carrier. If damaged, immediately contact your Representative. Any physical damage to the unit after acceptance is not the responsibility of the manufacturer.

Unpacking

Verify that all required parts and the correct quantity of each item have been received. If any items are missing, report shortages to your local representative to arrange for obtaining missing parts. Sometimes it is not possible that all items for the unit be shipped together due to availability of transportation and truck space. Confirmation of shipment(s) must be limited to only items on the bill of lading.

Handling

The sensor amperage and voltage ratings must be checked for compatibility to supply voltage prior to final electrical connection. Wiring must conform to local and national codes. Consult local code authorities for specific requirements.

Storage

Product is protected against damage during shipment. If the product cannot be installed and operated immediately, precautions need to be taken to prevent deterioration of the product during storage. The user assumes responsibility of the product and accessories while in storage. The manufacturer will not be responsible for damage during storage. These suggestions are provided solely as a convenience to the user.

Indoor Only

Do not store this product outdoors. The ideal environment for the storage of product is indoors, above grade, in a low humidity atmosphere which is sealed to prevent the entry of blowing dust, rain or snow. Temperatures should be evenly maintained between 30° to 110°F (-1° to 43°C) (wide temperature swings may cause condensation and “sweating” of metal parts). All accessories must be stored indoors in a clean, dry atmosphere.

Remove any accumulations of dirt, water, ice or snow and wipe dry before moving to indoor storage. Allow cold parts to reach room temperature to avoid “sweating” of metal parts. To dry parts and packages, use a portable electric heater to get rid of any moisture buildup. Leave coverings loose to permit air circulation and to allow for periodic inspection. The product should not be stored on the floor.

Inspection & Maintenance During Storage

While in storage, inspect product once per month. Keep a record of inspection and maintenance performed. If moisture or dirt accumulations are found on parts, the source should be located and eliminated.

Removing From Storage

As parts are removed from storage to be installed in their final location, they should be protected and maintained in a similar fashion until the fan equipment goes into operation.

Installation and Setup Guide

This guide provides instructions for how to install, wire, set and service ceiling fan sensor packages. When installed, this system is capable of automatically signaling the fan to run when desired conditions are met in the space.

Integrated Humidity Sensor

SP-A, sizes 50 to 390, new install or retrofit*, available in 115 volt only

1. For best performance of the humidity sensor, the fan will need to be located as close to the humidity source as acceptable per the fan’s instructions.
2. If sensor is not pre-installed, remove sensor from package, snap onto blower support bracket and slide sensor over the rivets as shown in Fig. 1.

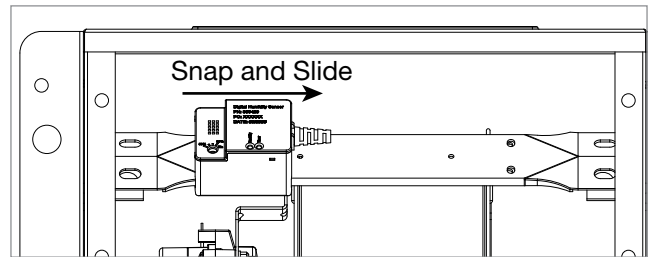

Fig. 1

NOTE

Sensor to be installed after ceiling finish is completed to prevent damage to sensor.

*Integrated humidity sensor (Part No. 386429) is not suitable for use in a retrofit application where the fan is installed directly above a bathtub or shower.

3. Avoid any kinking and/or sharp edges; route sensor cable underneath scroll and plug into “ACC” receptacle on junction box.
 - a. If fan is not equipped with “ACC” receptacle, remove motor connector from “FAN” female receptacle and plug included accessory adapter into “FAN” female receptacle.
 - b. Plug motor into “FAN” receptacle and sensor into “ACC” receptacle of accessory adapter.

- Set relative humidity based on desired performance. The lower the setting, the more sensitive the fan will be to changes in humidity levels as shown in Fig. 2.

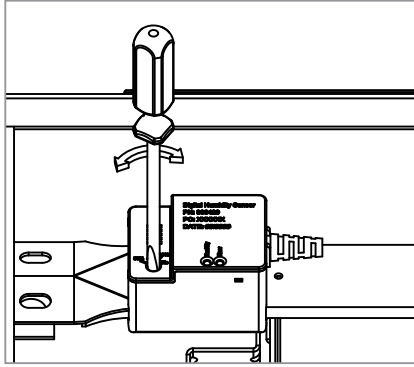

Fig. 2

SP-B, sizes 50 to 200, factory install only, available in 115 volt only

- For best performance of the humidity sensor, the fan will need to be located as close to the humidity source as acceptable per the fan's instructions.
- Set relative humidity based on desired performance. The lower the setting, the more sensitive the fan will be to changes in humidity levels. See Fig. 3.

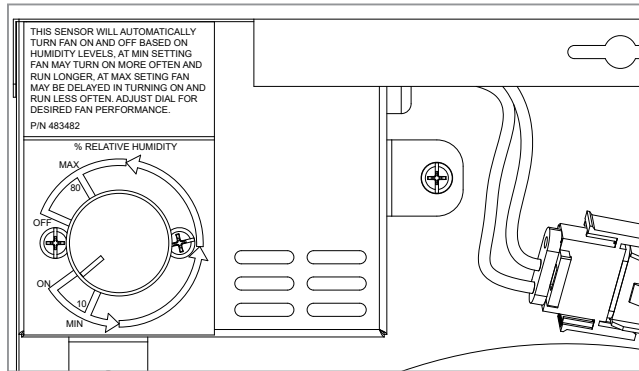
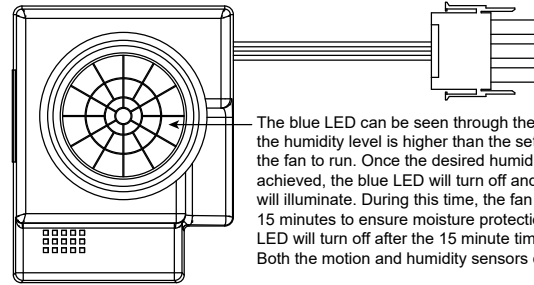
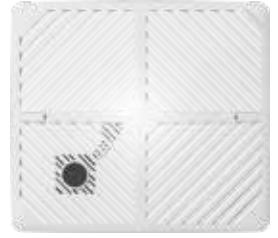

Fig. 3

Motion Sensor or Motion/Humidity Combination Sensor

- For best performance, position fan to not pick up unintended motion. Sensing diameter is set to 6 feet when installed in 8 foot ceilings.
- Adjust time delay as needed: 1, 2, 5, 10, 20 or 30 minutes.
- Avoid any kinking and/or sharp edges. Plug grille into "ACC" receptacle on junction box.
 - If fan is not equipped with "ACC" receptacle, remove motor connector from "FAN" female receptacle and plug included accessory adapter into "FAN" female receptacle.
 - Plug motor into "FAN" receptacle and sensor into "ACC" receptacle of accessory adapter.



The blue LED can be seen through the lens to indicate the humidity level is higher than the set point, enabling the fan to run. Once the desired humidity level is achieved, the blue LED will turn off and the green LED will illuminate. During this time, the fan will remain on for 15 minutes to ensure moisture protection. The green LED will turn off after the 15 minute timer is completed. Both the motion and humidity sensors can be disabled.

Front of Sensor

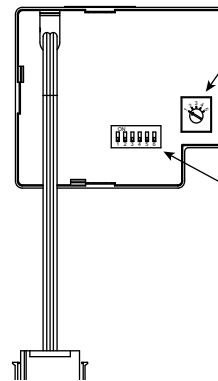

HUMIDITY SENSOR ADJUSTMENT:
 POSITION 1: 50% RELATIVE HUMIDITY
 POSITION 2: 60% RELATIVE HUMIDITY
 POSITION 3: 70% RELATIVE HUMIDITY
 POSITION 4: 80% RELATIVE HUMIDITY
 POSITION 5: DISABLE HUMIDITY SENSOR

TIME DELAY DIPSWITCH
 SWITCH 1 ON: 1 MINUTE
 SWITCH 2 ON: 2 MINUTES (DEFAULT)
 SWITCH 3 ON: 5 MINUTES
 SWITCH 4 ON: 10 MINUTES
 SWITCH 5 ON: 20 MINUTES
 SWITCH 6 ON: 30 MINUTES

SWITCHES 2, 4, & 6 ON: DISABLE MOTION SENSOR
 SWITCHES 1, 3, & 5 ON: TEST MODE (10 SECOND DELAY)

Back of Sensor

Wiring Diagram for Wall Switch Sensor Override

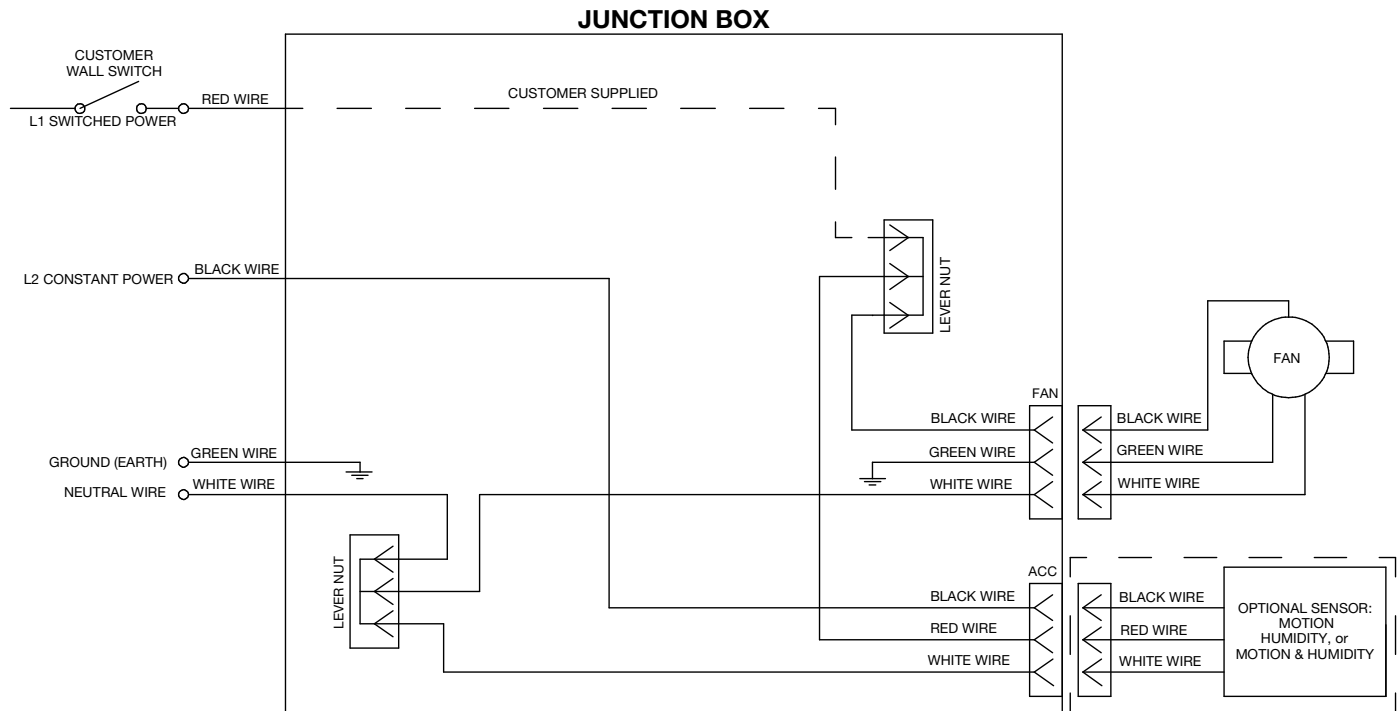

1. L1 Switched Power: Red Wire - Customer connection for switched power to the fan motor for high speed to be landed in lever nut connector.
2. L2 Constant Power: Black Wire - Provides customer connection for constant power to the motion sensor.
3. L3 Neutral Power: White Wire - Provides customer connection for neutral power to the fan motor.
4. Green Wire: Provides earth ground for customer connection.

Our Commitment

As a result of our commitment to continuous improvement, Greenheck reserves the right to change specifications without notice.

Product warranties can be found online at Greenheck.com, either on the specific product page or in the literature section of the website at Greenheck.com/Resources/Library/Literature.

Greenheck's Centrifugal Ceiling Exhaust and Inline Cabinet Fans catalog provides additional information describing the equipment, fan performance, available accessories, and specification data.

AMCA Publication 410-96, Safety Practices for Users and Installers of Industrial and Commercial Fans, provides additional safety information. This publication can be obtained from AMCA International, Inc. at www.amca.org.



Model: SP-B110

Alternate for Cook Gemini

Ceiling Exhaust Fan

Tags: EF-1 EF-2

Standard Construction Features:

- Corrosion resistant galvanized steel scroll and housing - White designer non-yellowing grille - Round outlet duct collar with integral backdraft damper - Single inlet forward curved wheel - Plug type disconnect - Adjustable mounting brackets

Selected Options & Accessories:

- Motor rated for continuous use
- Motor with Thermal Overload
- Motor with CSA Approval
- Motor with 40 Degree C Ambient Temperature
- UL/cUL 507 Listed - Electric Fan
- Solid State Speed Control, 6 Amp, Shipped Loose
- Round Hooded Wall Cap, (PN: WC-6) Shipped Loose
- ~~1 Function Switch, Single Pole Rocker (PN: 872243), Shipped Loose~~
- Round Duct Connection
- Isolation Kit, (PN: VI KIT-SP/CSP), Shipped Loose
- Adjustable easy installation mounting bracket
- Aluminum Grille with White Enamel Finish, (PN: 504879)
- Polypropylene Wheel Material
- Can Be Used to Comply with: ASHRAE 62.2 and Washington State Energy Code

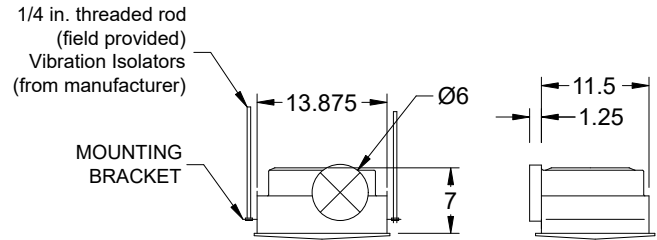
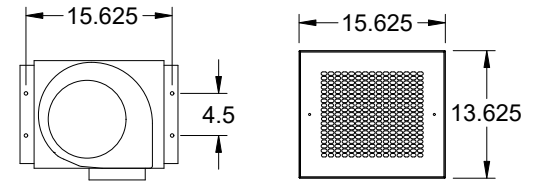

Dimensional	
Quantity	2
Weight w/o Acc's (lb)	10
Weight w/ Acc's (lb)	16

Performance	
Requested Volume (CFM)	75
Actual Volume (CFM)	75
Total External SP (in. wg)	0.3
Fan RPM	755
* FLA (A)	1.15
Elevation (ft)	256
Airstream Temp.(F)	70
Air Density (lb/ft3)	0.074
Sones	0.6

Motor	
Motor Mounted	Yes
** Input Watts (W)	80
Voltage/Cycle/Phase	115/60/1
Enclosure	ODP

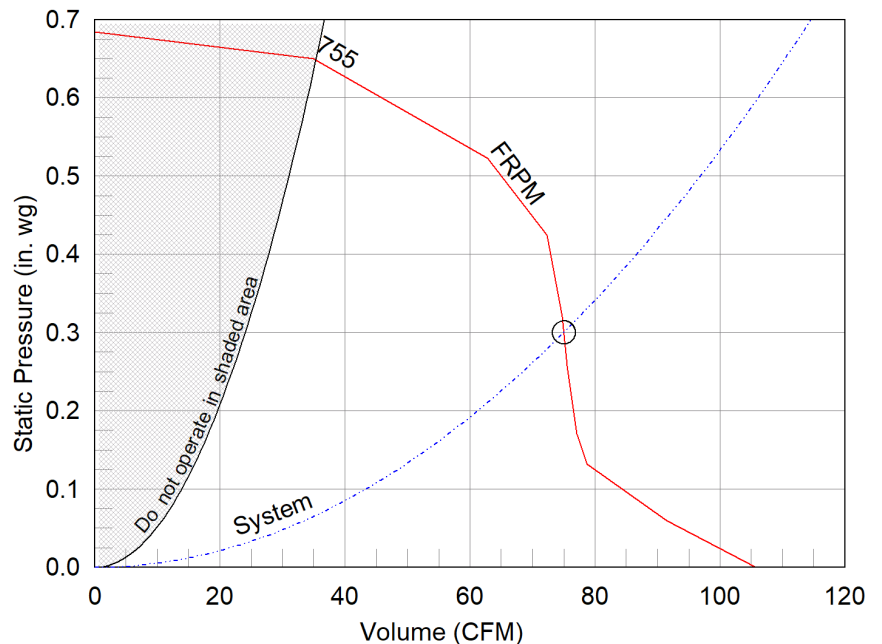

- Operating point at Total External SP
- Fan curve
- - - System curve

Notes:

- All dimensions shown are in units of in.
- *FLA is approximate and will vary slightly with the motor.
- Sones - calculated using AMCA 301 at 5 ft
- ** Wattage is shown at free air.
- ** Wattage is approximate and may vary between motors.



Round Duct Connector

Model: RDC

Standard Construction Features:

-Constructed of Polypropylene - Replaces the square discharge duct connector and damper using the existing mounting holes

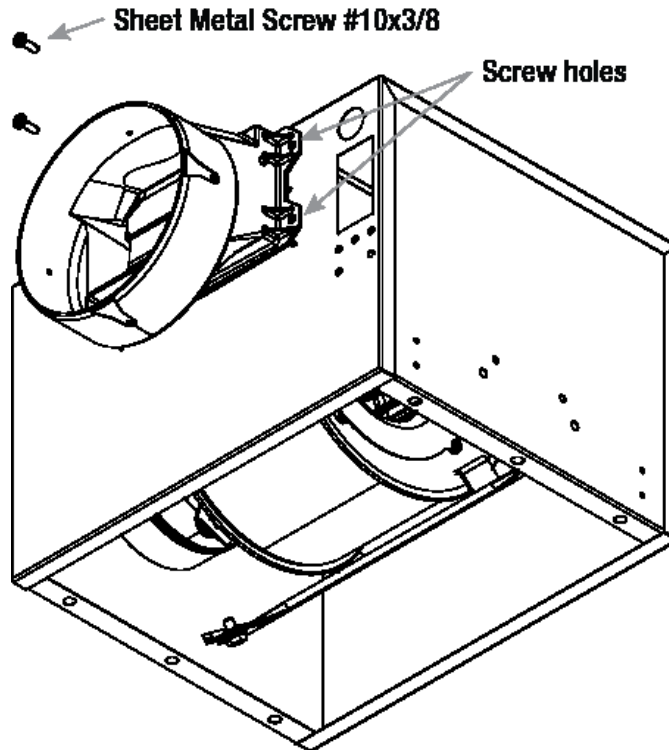

Notes: All dimensions shown are in units of in.

Discharge Accessory

Type: Wall Cap - Rnd

Standard Construction Features:

- Aluminum construction - Designed for outside wall application - Built in damper

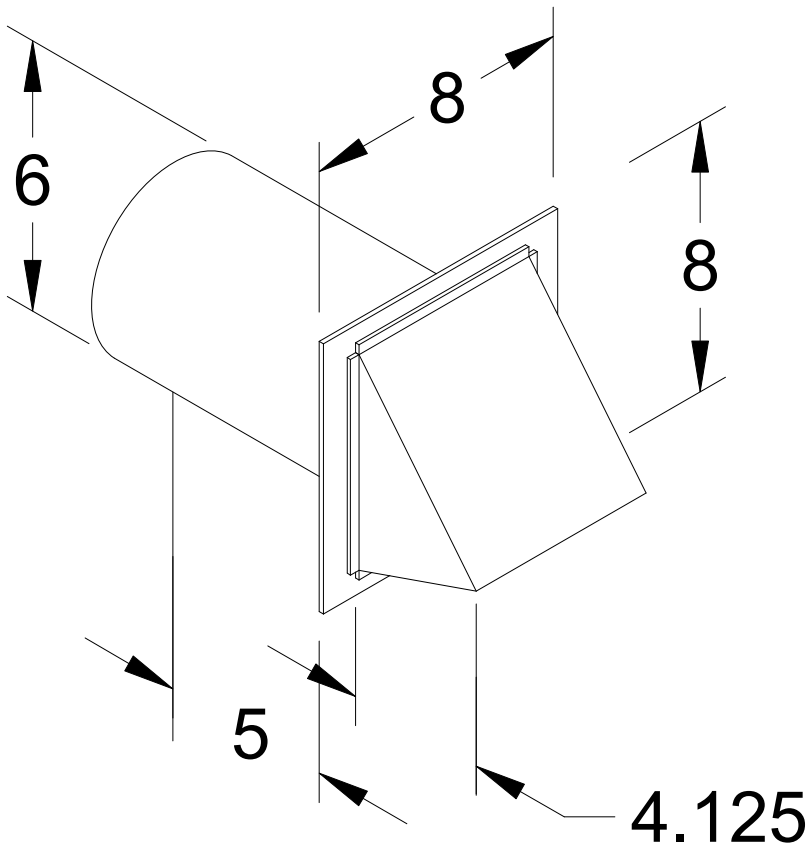

Notes: All dimensions shown are in units of in.

Isolation Kit
Type: Hanging

Standard Construction Features:

- Neoprene vibration isolation for hanging installation - Kit includes four isolators and all hardware necessary for mounting one unit except for the 0.25 in. x 20 in. threaded rod to be supplied by others - Fan mounting brackets include prepunched mounting holes for ease of installation

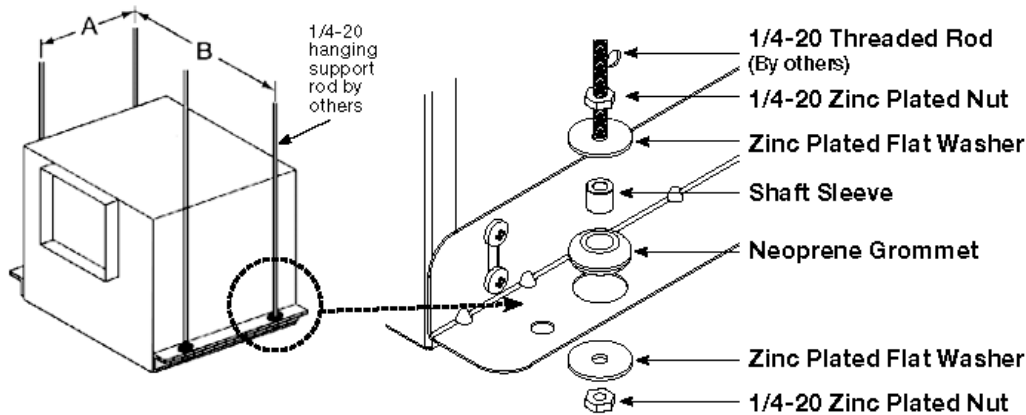

Unit Size	A	B
B50-B200	4 1/2 (114)	15 5/8 (397)
A50-A190	5 1/2 (140)	14 5/8 (371)
A200-A390	6 3/4 (171)	15 1/2 (394)
A410, A510, A710, A780	9 1/4 (235)	19 5/8 (498)
A700	5 1/2 (140)	25 1/8 (638)
A900 - A1050, A1410 - A1550	9 1/4 (235)	25 3/8 (645)
A1750, A2150	9 1/4 (235)	36 3/4 (933)
A3600	9 1/4 (235)	48 5/8 (1235)
All dimensions shown in inches (millimeters).		

Description	Qty
Neoprene Grommets	4
1 x 32 Zinc Plated Nuts	8
Zinc Plated Flat Washers	8
3/8 x 3/16 Shaft Sleeves	4

Manual Switch
Model: 1 Function

Standard Construction Features:

Single pole rocker switch assembly with plate cover, rated for 120/277V, 15A, UL Listed.

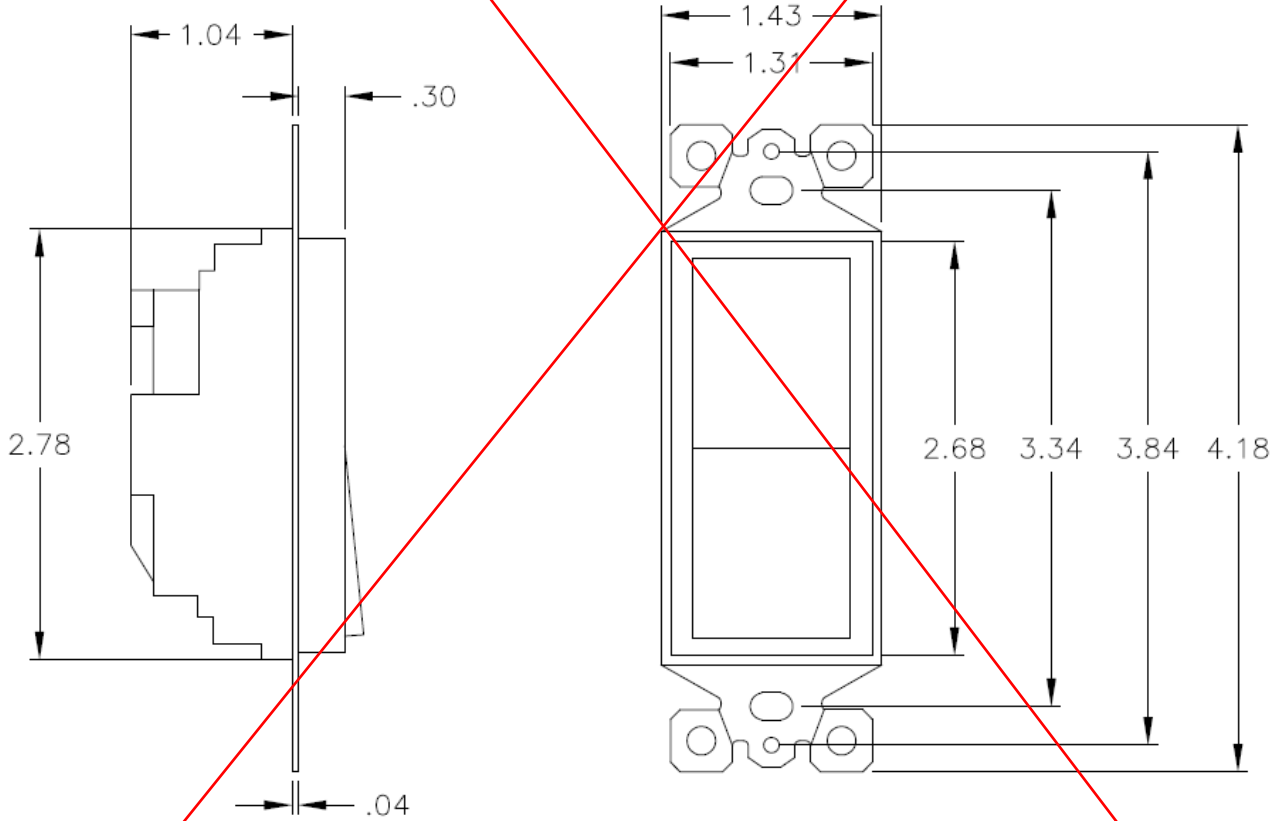

Notes: All dimensions shown are in units of in.