

Quality People. Building Solutions.

Comfort Systems USA (Arkansas), Inc.
P.O. Box 16620
Little Rock, AR 72231
Phone 501-834-3320
Fax 501-834-5416

Date: 10/4/2022

Return Request: 10/10/2022

Project: ATU – Jones Hall

Supplier: Airetech

Manufacturer: Greenheck

Submittal: Packaged HVAC Units (VAU-1)

Submittal Number: 23 74 13-01

Drawing # and Installation: Mechanical Drawings

ARCHITECT

SCM Architects
1400 Kirk Rd. Suite 220
Little Rock, AR 72223
501-224-3055

ENGINEER

Pettit & Pettit
201 E. Markham, Suite 400
Little Rock, AR 72201
501-374-3731

GENERAL CONTRACTOR

Alessi Keyes Construction
10623 Maumelle Blvd.
N. Little Rock, AR 72113
501-225-6699

MECHANICAL SUBCONTRACTOR

Comfort Systems USA (Arkansas), Inc.
9924 Landers Rd.
N. Little Rock, AR 72117
501-834-3320

Notes:

CSUSA PROJECT NO.

22-620

sean@comfortar.com

ALESSI KEYES CONSTRUCTION
REVIEWED FOR GENERAL COMPLIANCE
WITH CONTRACT DOCUMENTS
Charley Dawson 10/17/2022

9924 Landers Rd.
No. Little Rock, AR 72117

Installation, Operation and Maintenance Manuals

Job Title: ATU Jones Hall VAU

Job Site: ARKANSAS TECH UNIVERSITY
203 WEST O STREET

RUSSELLVILLE, AR 72801
United States

Customer PO#: ATU JONES HALL

Engineer: Pettit

Elevation: (ft) 338

Date: 1/10/2023

Submitted By: Forrest Moseley

Agent Order#: 71022FM02

AIRETECH CORPORATION

7631 NORTSHORE PL

NORTH LITTLE ROCK, AR 72118

US

Phone: (501)280-0404

Fax: (501)280-9200

Email Address: lizzy.amador@airetechcorp.com



P.O. Box 410 Schofield, WI 54476 (715) 359-6171 FAX (715) 355-2399 www.greenheck.com

C:\Users\lizzy.amador.AIRETECHCORP\Airetech Corporation\Airetech - LR-Sales\Greenheck\Jobs\ATU Jones Hall VAU.gfcj

Job Name: ATU Jones Hall VAU

Product IOMs

Mark Name	Model Name
VAU-1	RVE

Installation, Operation and Maintenance Manual

Please read and save these instructions for future reference. Read carefully before attempting to assemble, install, operate or maintain the product described. Protect yourself and others by observing all safety information. Failure to comply with these instructions will result in voiding of the product warranty and may result in personal injury and/or property damage.



Technical Support
Call: 1-866-478-2574
Email: DOAS@greenheck.com



General Safety Information

This appliance is not intended for use by persons (including children) with reduced physical, sensory or mental capabilities, or lack of experience and knowledge, unless they have been given supervision or instruction concerning use of the appliance by the person responsible for their safety. Children should be supervised to ensure they do not play with this appliance. Personnel should have a clear understanding of these instructions and should be aware of general safety precautions. Improper installation can result in electric shock, possible injury due to coming in contact with moving parts, as well as other potential hazards. Other considerations may be required if high winds or seismic activity are present. If more information is needed, contact a licensed professional engineer before moving forward.

1. Follow all local electrical and safety codes, as well as the National Electrical Code (NEC), the National Fire Protection Agency (NFPA), where applicable. Follow the Canadian Electrical Code (CEC) in Canada.
2. All moving parts must be free to rotate without striking or rubbing any stationary objects.
3. Unit must be securely and adequately grounded.
4. Do not spin wheel faster than maximum cataloged fan RPM. Adjustments to fan speed significantly affect motor load. If the fan RPM is changed, the motor current should be checked to make sure it is not exceeding the motor nameplate amps.
5. Verify that the power source is compatible with the equipment.
6. Never open access doors to the unit while it is running.

WARNING

The roof lining contains high voltage wiring. To prevent electrocution, do not puncture the interior or exterior panels of the roof.

DANGER

- Always disconnect power before working on or near this equipment. Lock and tag the disconnect switch or breaker to prevent accidental power up.
- If this unit is equipped with optional gas accessories, turn off gas supply whenever power is disconnected.

CAUTION

This unit is equipped with a compressed refrigerant system. If a leak in the system should occur, immediately evacuate the area. An EPA Certified Technician must be engaged to make repairs or corrections. Refrigerant leaks may also cause bodily harm.

CAUTION

When servicing the unit, the internal components may be hot enough to cause pain or injury. Allow time for cooling before servicing.

Table of Contents

General Safety Information	1
Receiving, Handling, Storage	3
Product Overview	4
Subassemblies	5
Installation	7
Recommended Electrical and	
Gas Supply Entry Locations	13
Piping Installation	14
Electrical Information.	15
Control Center Components.	16
Component Operation.	17
Optional Component Operation	17
Factory-Installed Refrigeration System.	21
Start-Up Components.	25
Optional Polymer Energy Wheel	28
Optional Aluminum Energy Wheel	30
Optional Energy Core	31
Troubleshooting.	32
Routine Maintenance	38
Reference	
Venting Connection Locations	41
Rated Airflow.	43
Our Commitment.	Backcover



Receiving

This product may have been subject to road salt during transit. If so, immediately wash off all visible white residue from all exterior surfaces. Upon receiving the product, check to ensure all line items are accounted for by referencing the delivery receipt or packing list. Inspect each crate or carton for shipping damage before accepting delivery. Alert the carrier if any damage is detected, **do not refuse shipment**. The customer shall make notation of damage (or shortage of items) on the delivery receipt and all copies of the bill of lading which should be countersigned by the delivering carrier. If damaged, immediately contact your manufacturer's representative. Any physical damage to the unit after acceptance is not the responsibility of the manufacturer.

Handling

Units are to be rigged and moved by the lifting brackets provided. Location of brackets varies by model and size. Handle in such a manner as to keep from scratching or chipping the coating. Damaged finish may reduce ability of unit to resist corrosion.

Unpacking

Verify that all required parts and the correct quantity of each item have been received. If any items are missing, report shortages to your local representative to arrange for obtaining missing parts. Sometimes it is not possible that all items for the unit be shipped together due to availability of transportation and truck space. Confirmation of shipment(s) must be limited to only items on the bill of lading.

Storage

Units are protected against damage during shipment. If the unit cannot be installed and operated immediately, precautions need to be taken to prevent deterioration of the unit during storage. The user assumes responsibility of the unit and accessories while in storage. The manufacturer will not be responsible for damage during storage. These suggestions are provided solely as a convenience to the user.

The ideal environment for the storage of units and accessories is indoors, above grade, in a low humidity atmosphere which is sealed to prevent the entry of blowing dust, rain, or snow. Units designed for outdoor applications may be stored outdoors. All accessories must be stored indoors in a clean, dry atmosphere.

Indoor

Maintain temperatures evenly to prevent condensation. Remove any accumulations of dirt, water, ice, or snow and wipe dry before moving to indoor storage. To avoid condensation, allow cold parts to reach room temperature. Leave coverings loose to permit air circulation and to allow for periodic inspection.

The unit should be stored at least 3½ in. (89 mm) off the floor. Clearance should be provided to permit air circulation and space for inspection.

Outdoor

The unit should be placed on a level surface to prevent water from leaking into the unit. The unit should be elevated so that it is above water and snow levels. Ensure sufficient support to prevent unit from settling into soft ground. Locate parts far enough apart to permit air circulation, sunlight, and space for periodic inspection. To minimize water accumulation, place all unit parts on blocking supports so that rain water will run off.

Do not cover parts with plastic film or tarps as these cause condensation of moisture from the air passing through heating and cooling cycles.

Inspection and Maintenance

While in storage, inspect units once per month. Keep a record of inspection and maintenance performed.

If moisture or dirt accumulations are found on parts, the source should be located and eliminated. At each inspection, rotate the fan wheel by hand ten to fifteen revolutions to distribute lubricant on motor. If paint deterioration begins, consideration should be given to touch-up or repainting. Units with special coatings may require special techniques for touch-up or repair.

Machined parts coated with rust preventive should be restored to good condition promptly if signs of rust occur. Immediately remove the original rust preventive coating with petroleum solvent and clean with lint-free cloths. Polish any remaining rust from surface with crocus cloth or fine emery paper and oil. Do not destroy the continuity of the surfaces. Wipe thoroughly clean with Tectyl® 506 (Ashland Inc.) or the equivalent. For hard to reach internal surfaces or for occasional use, consider using Tectyl® 511M Rust Preventive, WD-40® or the equivalent.

Removing from Storage

As units are removed from storage to be installed in their final location, they should be protected and maintained in a similar fashion until the equipment goes into operation.

Prior to installing the unit and system components, inspect the unit assembly to make sure it is in working order.

1. Check all fasteners, set screws on the fan, wheel, bearings, drive, motor base, and accessories for tightness.
2. Rotate the fan wheel(s) by hand and assure no parts are rubbing.

Product Overview

A horizontally configured High Percentage Outdoor Air unit designed for installation either indoors or outdoors. Each unit has multiple options for cooling and/or heating. The unit is designed to replace air that is exhausted from the building and also heat and cool, as needed. The air volume produced by the unit is constant, but can be optionally modulated to provide a variable air volume (VAV) and recirculation is also offered as an option.

Cooling

Units have the following cooling options available:

- Packaged DX
- Split DX (thermal expansion valve is field-provided)
Not available on housing sizes 10, 75/150, 110/145/180.
- Chilled water coil
- Air-source heat pump (ASHP)
Not available on housing sizes 10, 75/150, 110/145/180.

Packaged DX and air-source heat pumps are shipped fully charged with refrigerant and are ready for operation upon arrival.

Heating

There are four different optional heat sources that can be ordered for this unit:

- Indirect gas-fired furnace with one or two sets of heat exchangers
- Electric heat with infinitely variable SCR control
- Hot water coil
- Air-source heat pump (ASHP)
Not available on housing sizes 10, 75/150, 110/145/180.

Airflow Arrangement

The unit is capable of Constant Air Volume (CAV), Variable Air Volume (VAV), 100% Outdoor Air and have recirculating air options.

Safety Listing

Models are listed per ANSI/UL 1995, Heating and Cooling Equipment and are ETL Certified.

Models and Capacities

Model	Cooling Capacity
RV-10	3 to 7 tons
RV-25	5 to 15 tons
RV-45	15 to 30 tons
RV-75	25 to 50 tons
RV-110	30 to 70 tons
RVE-40	5 to 15 tons
RVE-85	15 to 30 tons
RVE-150	25 to 50 tons
RVE-180	30 to 70 tons
RVC-35	5 to 15 tons
RVC-65	15 to 30 tons
RVC-145	30 to 70 tons

Subassemblies

Blower - Either one, two, or three plenum-type fans. All units are equipped with a plenum fan for Supply Air and a second may be selected for Exhaust (Relief) Air.

Coils - Evaporator coil (optional)
Condenser coil (optional, packaged DX only)
Indoor coil (optional, air-source heat pump only)
Outdoor coil (optional, air-source heat pump only)
Water coil (optional)
Reheat coil (optional)

Compressors - Each unit having packaged DX will have either one, two, three, or four refrigerant compressors. Optionally, one of the compressors may be a digital or inverter scroll type compressor. Air-source heat pump units will have one inverter scroll compressor and may contain a second staged compressor.

Dampers - Motorized intake air damper, optional motorized recirculating damper. Optional return air damper. Optional gravity-type exhaust damper.

Optional Barometric Relief Damper - Used during economizer mode of the unit when building pressure increases, relief damper will open due to over pressurization.

Electric Heater - An SCR controlled electric heater (not shown) is available on the units. It has its own control panel and may require a separate power supply. See unit-specific wiring diagram.

Supply Filters - Housing size 110/145/180 is available with a filter bank depth of either 2, 4 or 6-inch. All other housings are available with a filter bank depth of either 2 or 4-inch.

Indirect Gas-Fired Furnace - Housing sizes 10, 25/35/40 and 45/65/85, use furnace model PVG. Housing sizes 75/150 use furnace models PVG 600-800 or HMA 1000-1200. Housing sizes 110/145/180 use furnace model HMA 600-1200.

Packaged DX System - Any unit may be ordered with a packaged DX system. Housing size 10 will use one compressor; housing size 25/35/40 will include one compressor; housing size 45/65/85 will include two compressors; housing size 75/150 will include one or two compressors; housing size 110/145/180 will include four compressors; a condenser coil(s) and evaporator coil(s) and all required components. Units that have packaged DX are charged with R410A refrigerant. Do not use tools or parts designed for other refrigerants on these units.

Air-Source Heat Pump - Units having an air-source heat pump will include either one or two compressors, an indoor and outdoor coil, and all required components. Air-source heat pump units are charged with R410A refrigerant. Do not use tools or parts designed for other refrigerants on these units. Not available on housing sizes 10, 75/150, 110/145/180.

Split DX - The unit may be ordered with a split DX system for connection to a building cooling system. Thermal expansion valve (TXV) is field-provided. Not available on housing sizes 10, 75/150, 110/145/180.

Vestibule - Some units may be ordered with a factory-assembled vestibule that is to be field-attached to the side of the unit. See lifting instructions.

Subassemblies

RV AND RVE

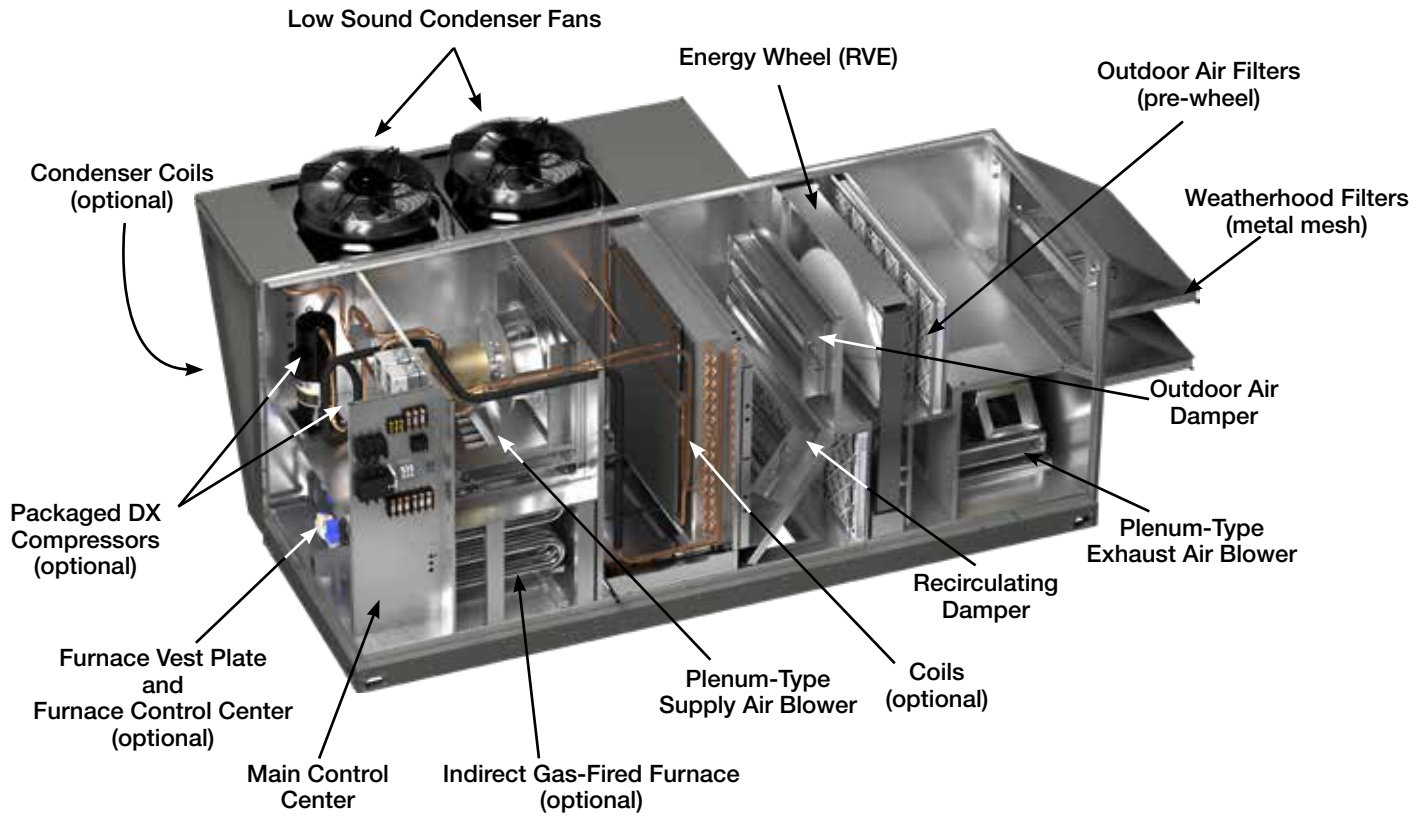

RVC

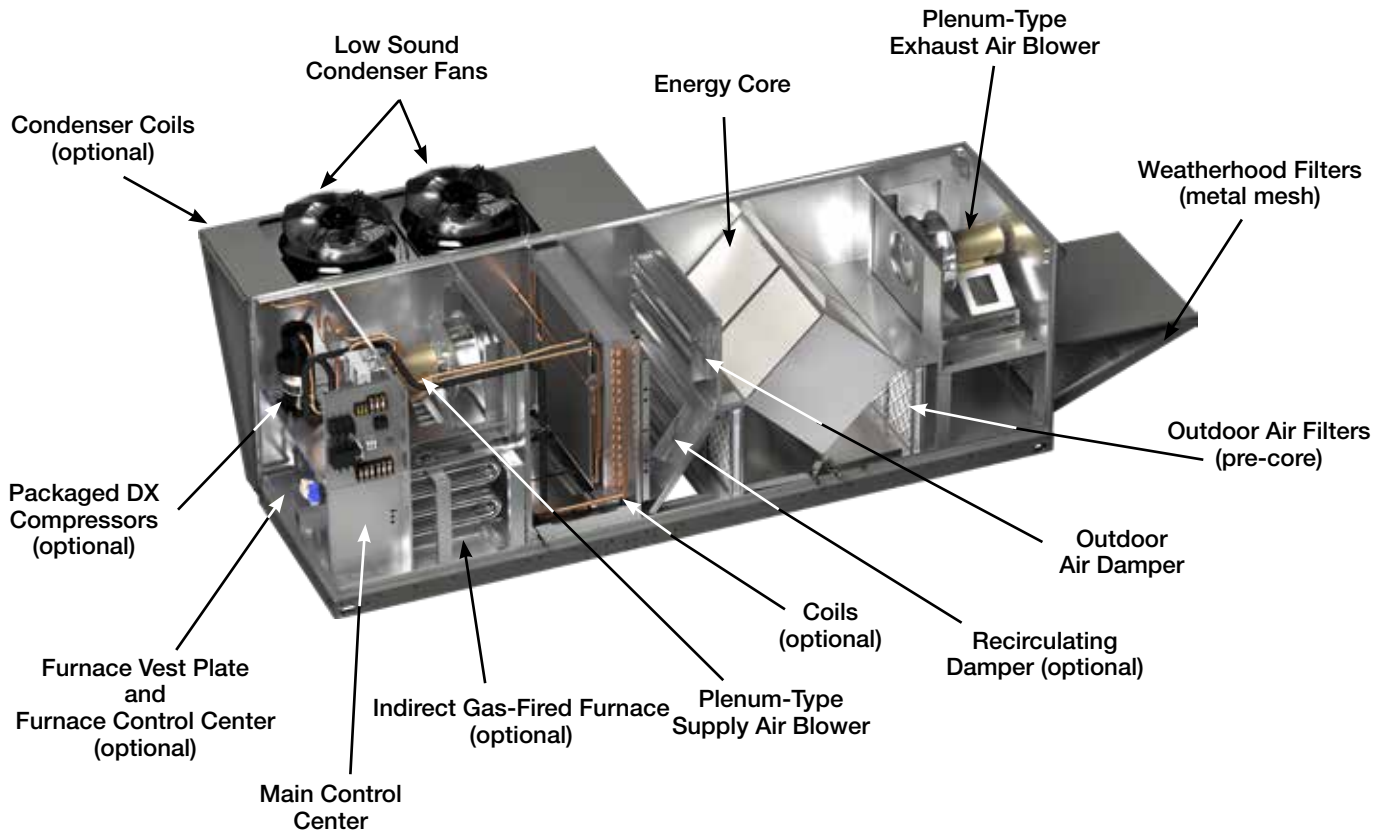

Installation

Typical Unit Weights and Dimensions

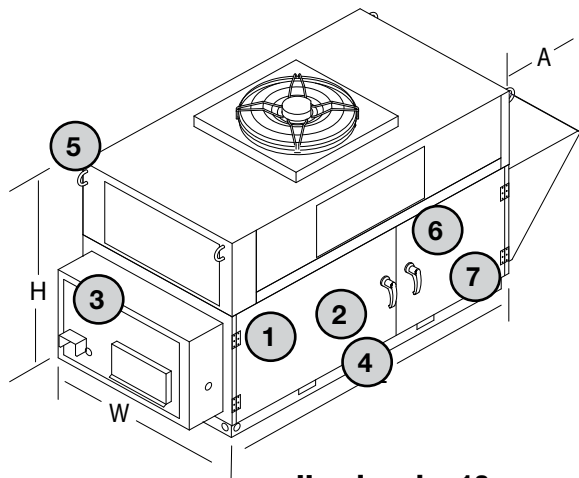

Housing size 10

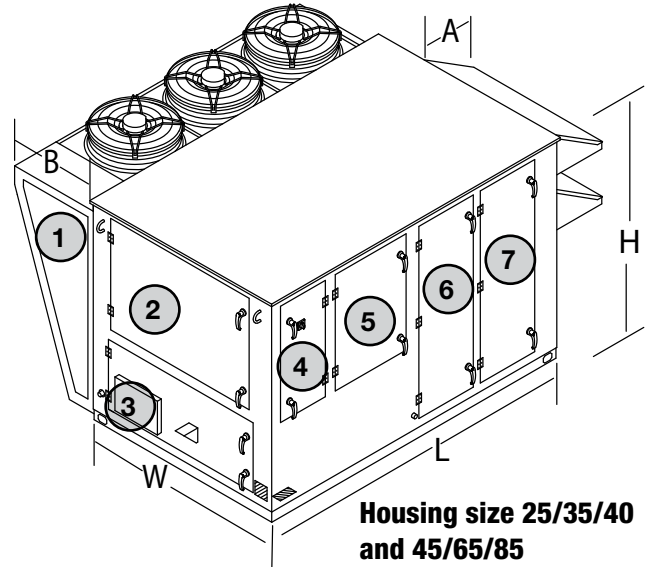

**Housing size 25/35/40
and 45/65/85**

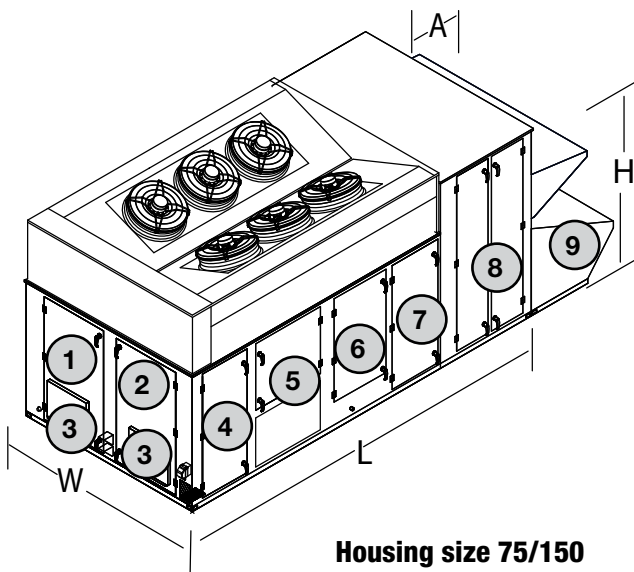

Housing size 75/150

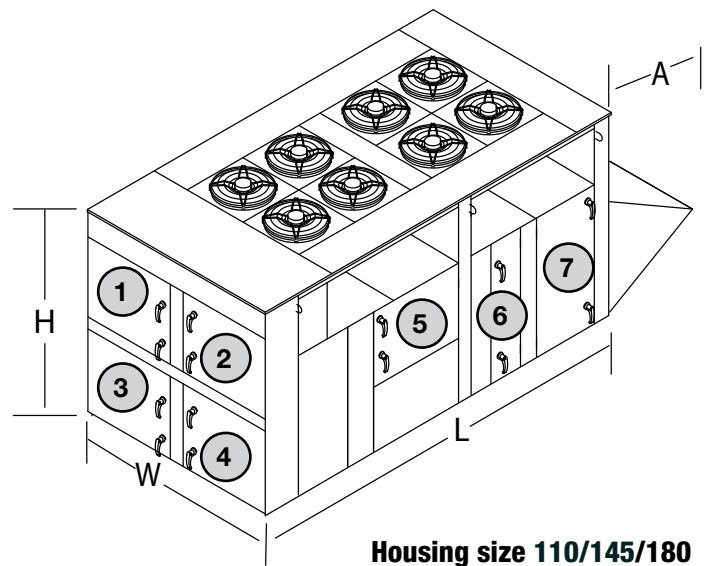

Housing size 110/145/180

Component Access	
1	Optional Inverter Compressor VFD
2	Optional Compressor/Electrical
3	Optional Gas Furnace/Optional Electric Heater
4	Electrical
5	Supply Blower
6	Coil
7	Filters
8*	Exhaust Blower/Optional Electric Preheat
9	Powered Exhaust Blower Section

* When a powered exhaust fan (or RVE/RVC) is selected, door 8 will be to the immediate right of door 7.

Installation

Typical Unit Weights and Dimensions

Model	Nominal tonnage (tons)	Height (H)	Width (W)	Length (L)	Intake (A)	Condensing Section (B)	Nominal weight (lbs)	Outdoor Intake	Supply Discharge	Return Intake	Exhaust Discharge
RV-10	3-7	58.1	44.0	82.2 ⁹	22.3	NA	1,180	End	Bottom or Side	Bottom or End ²	NA
RV-25	5-15	59.3	52.5	98.6 ⁶ /149.5 ⁷	22.1	30.1	2,700			Bottom, End ¹¹ or Side ¹	End ³ or Side ¹
RV-45	15-30	72.5	68.2	109 ⁶ /163.2 ⁷	27.1	30.1	4,375			Bottom, End ¹¹ or Side ¹	End
RV-75	25-50	101.3	98	155.2 ⁶ /188 ⁴	39/48.4 ⁸	NA	6,500			Bottom or End ¹⁰	Side
RV-110	30-70	99.5	96	185	45.3	NA	7,950				
RVE-40	5-15	59.3	52.5	149.5/180.5 ⁴	22.1	30.1	3,400	End	Bottom or Side	Bottom, or Side ¹	Side ¹
RVE-85	15-30	72.5	68.2	163.2/197.2 ⁴	27.1	30.1	4,800			Bottom or Side	End
RVE-150	25-50	101.3	98	199.6 ⁵ /233.8 ⁴	48.4	NA	8,000				
RVE-180	30-70	99.5	96	263 ⁵ /307 ⁴	45.3	NA	10,450				
RVC-35	5-15	59.3	52.5	180.5	40	30.1	3,800	End	Bottom or Side	Bottom	Side
RVC-65	15-30	72.5	68.2	197.2	38	30.1	5,675			Bottom or Side	
RVC-145	30-70	99.5	96	308.8 ⁵ /353 ⁴	46	NA	12,000				

All dimensions are shown in inches. Weight is shown in pounds and includes largest supply and exhaust fans, PDX with reheat, largest indirect-gas fired furnace, and all dampers. Actual weights will vary based on the unit configuration.

¹ Only available with powered exhaust

² Only available without barometric relief

³ Only available with barometric relief

⁴ Length with side return

⁵ Length with bottom return

⁶ Length with bottom or end return

⁷ Length with powered exhaust

⁸ Length with powered exhaust bumpout

⁹ Optional indirect gas-fired furnace bumpout length is additional 13.3 inches

¹⁰ Only available without powered exhaust

¹¹ Only available without powered exhaust and without barometric relief

Installation

Service Clearances

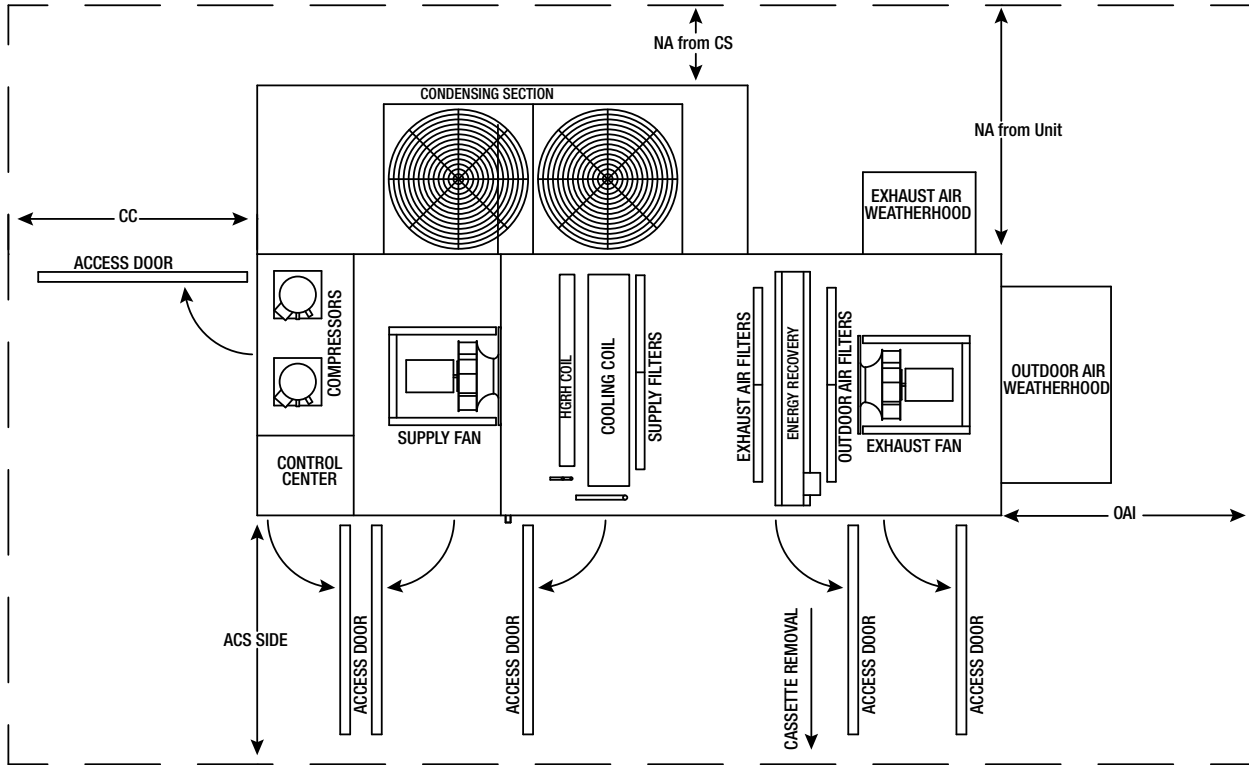

Model	ACS Access Side	CC Control Cabinet End		OAI Outdoor Air Intake		*NA from Unit	NA from Condensing Section	NA from Piping Vestibule (not shown)
		Other	Indoor Mounted with IG Furnace	Outdoor Mounted	Indoor Mounted			
RV-10	50	42	NA	36	NA	24	NA	NA
RV-25	40	42	72	42	18	24	18	30
RV-45	36	58	72	54	18	24	18	30
RV-75	48	48	NA	87	NA	48	NA	NA
RV-110	48	48	NA	93	NA	48	NA	NA
RVE-40	40	42	72	42	18	24	18	30
RVE-85	36	58	72	54	18	24	18	30
RVE-150	48	48	NA	87	NA	48	NA	NA
RVE-180	48	48	NA	93	NA	48	NA	NA
RVC-35	40	42	NA	88	NA	24	18	30
RVC-65	36	58	NA	82	NA	24	18	30
RVC-145	48	48	NA	93	NA	48	NA	NA

All dimensions are shown in inches.

*No condensing section or piping vestibule, or unit has top condensing section.

Installation

Additional Clearances for Packaged DX Units

Packaged DX units require additional clearance because they must have unrestricted air movement around the condenser coil and condenser fans. Hot air is being discharged from the condenser fans during operation. Enough clearance must be provided to avoid recirculation or coil starvation. When equipped with condenser coils, the unit should never be placed under an overhang or inside a building. A minimum of 48 inches above the condenser fans is acceptable, but unobstructed is strongly recommended.

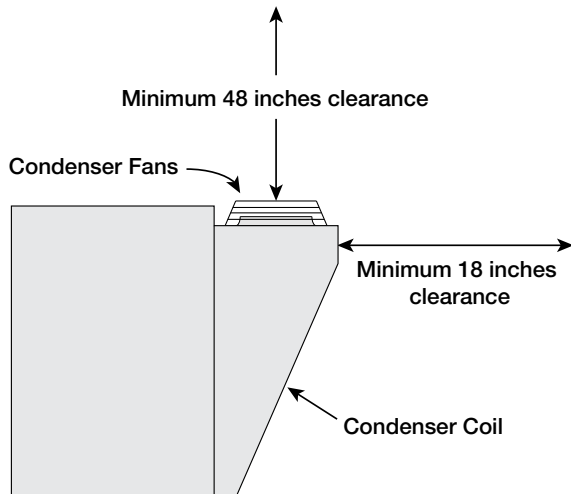

End view of rooftop unit with Packaged DX

Additional Clearances for Air Source Heat Pump

IMPORTANT

Air-source heat pumps are equipped with a defrost cycle to remove ice from the outdoor coil. During defrost cycles, melted water may drip from the bottom of the refrigeration section under the outdoor coil. In cold climates, proper drainage/heat tape must be installed under the outdoor coil to prevent the buildup of ice on the roof.

Air-source heat pump units require additional clearance because they must have unrestricted air movement around the outdoor coil and outdoor fans. Enough clearance must be provided to avoid recirculation or coil starvation. Air-source heat pump units should never be placed under an overhang or inside a building. A minimum of 48-inches above the outdoor fans is acceptable, but unobstructed is strongly recommended.

Handling Concerns for Packaged DX or Air-Source Heat Pump

Units with PDX or ASHP have a system that is pressurized with refrigerant. If damage occurs, the refrigerant could leak into the atmosphere or cause bodily harm due to the extreme cold nature of expanding refrigerant. Use protective equipment such as gloves and safety glasses to minimize or prevent injury in case of a system leak during installation.

Before Lifting

Before lifting, be sure that all shipping materials have been removed from the unit.

Vestibule

Determine whether or not the unit has a vestibule that must be field-attached to the side of the unit. Vestibules are shipped assembled but detached from the unit. They have lifting lugs on them so they can also be lifted by crane, but the installed location of the unit may make it preferable to install the vestibule on the unit prior to lifting.

Field Power Access

Determine where high voltage and low voltage wiring is to be brought into the cabinet. If wiring is to be brought into the cabinet through the floor, see Alternate Supply Entry Locations in this manual. If unit is to be installed on a roof, cut access openings in the roof deck as needed.

Installation

Lifting

1. Ensure that all shipping materials have been removed from unit.
2. To assist in determining rigging requirements, weights are provided in the Unit Weights & Dimensions section of this manual.
3. Unit must be lifted by all lifting lugs provided at top for all housing sizes except the 75/150 which must be lifted from the bottom.
4. Spreader bars must span the unit to prevent damage to the cabinet by the lift cables.

WARNING

Spreader bars are required to prevent damage to the cabinet, failure to do so can result in damage that is the installer's responsibility.

5. Never rest the spreader bar on the unit.
6. Always test-lift the unit to check for proper balance and rigging before hoisting to desired location.
7. Never lift unit by weatherhood.
8. Never lift units in windy conditions.
9. Preparation of curb and roof openings should be completed prior to lifting unit to the roof.
10. Check to be sure that gasketing (supplied by others) has been applied to the top of the curb prior to lifting the unit and setting on the curb.
11. Do not use forklifts for handling unit on housing sizes 25/35/40, 45/65/85, 75/150, or 110/145/180.
12. If using forklift on housing 10, use forks with 48-inch length and ensure forks extend to opposite side of unit using factory-installed forklift pockets at unit base.



Roof Curb Mounting

Roof curb details, including duct locations and dimensions, are to be found in the roof curb assembly instructions.

Rooftop units require curbs to be mounted first. The duct connections must be located so they will be clear of structural members of the building.

1. Factory-supplied roof curbs. Roof curbs are model GKD which are shipped in a knockdown kit (includes duct adapters) and require field assembly (by others) on all units except RV-110, RVE-180 and RVC-145 which are shipped assembled. Assembly instructions are included with the curb kit.

2. Install curb. Locate curb over roof opening and fasten in place. Check that the diagonal dimensions are within $\pm 1/8$ inch of each other and adjust as necessary. For proper coil drainage and unit operation, it is important that the installation be level. Shim the curb as required to level. Install gasketing on top surface of curb (provided by others).

3. Install ductwork. Installation of all ducts should be done in accordance with SMACNA and AMCA guidelines. Duct adapters are provided to support ducts prior to setting the unit.

4. Set the unit. Lift unit to a point directly above the curb and duct openings. Guide unit while lowering to align with duct openings. Roof curbs fit inside the unit base. Make sure the unit is properly seated on the curb and level.

5. Fasten the unit. Fasten the unit to the curb/equipment support(s) using appropriate methods. The installer is responsible for determining appropriate support and fastening methods to ensure compliance with all applicable codes.

6. Install vestibule. If unit was ordered with a vestibule and it has not yet been attached to the unit, caulk and attach the vestibule at this time.

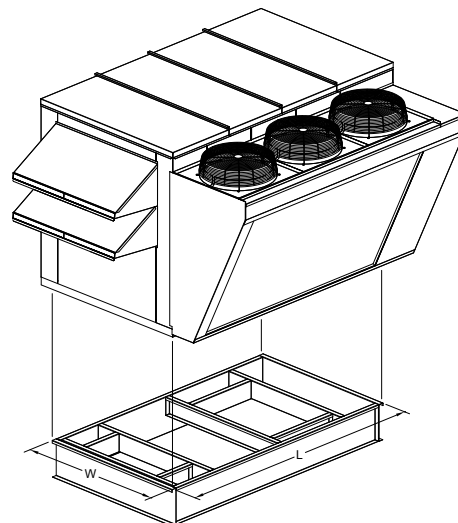

Typical Unit with Condensing Section and Factory-Supplied Curb Kit

Installation

Optional Piping Vestibule

If the unit was ordered with the vestibule, the NA (Non-Access side) clearance dimension must be measured from the vestibule.

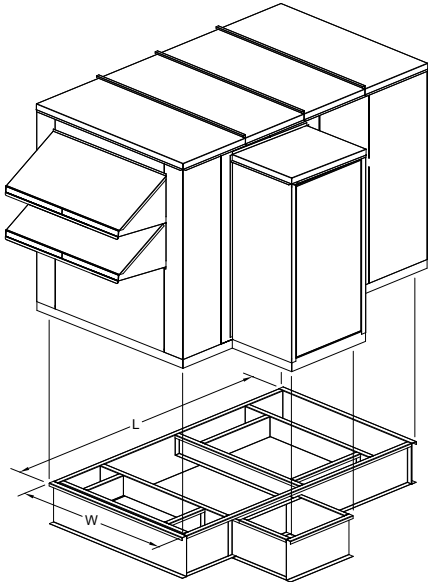

Typical Unit with Piping Vestibule and Factory-Supplied Curb Kit

Rail Mounting and Layout

- The units may be installed on rails provided and installed by others. Ensure that rails are designed to handle the weight of the unit and provide proper load distribution on building supports.
- Make sure that rail positioning does not interfere with the openings on the unit.
- Rails should run the width of the unit and extend beyond the unit a minimum of 12 inches on each side.
- Set unit on rails.

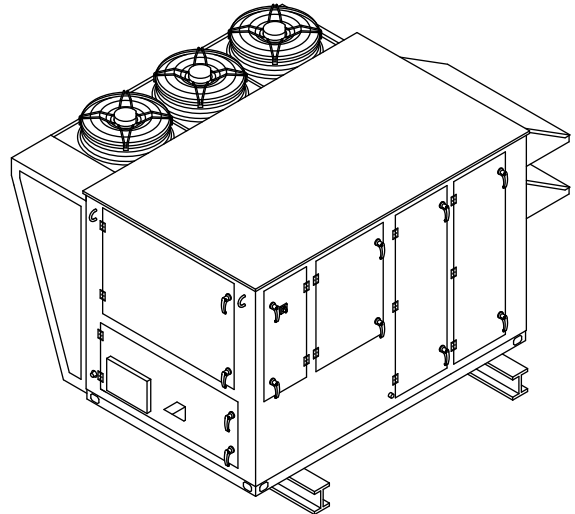

Typical Unit Installed on Rails Supplied by Others

Ductwork Configurations

NOTE

Downblast Discharge Ductwork - whenever downblast discharge is used, the ductwork directly beneath the unit must be connected with either a "T" or an "L" configuration and the area directly beneath the heat source **must not have any openings** such as louvers or grates.

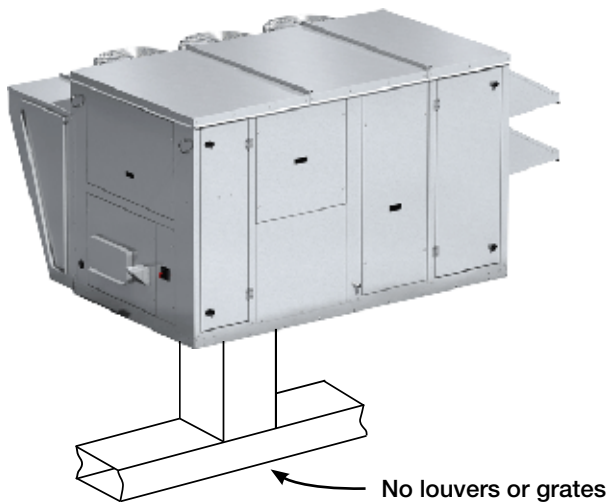

Recommended Electrical and Gas Supply Entry Locations

Manufacturer recommends that electrical service and gas supply be brought into the cabinet through the end wall, as shown below. There are three penetrations into the cabinet that are required; one for high voltage supply wiring, one for low voltage control wiring and one for either gas supply or high voltage supply wiring for an electric heater.

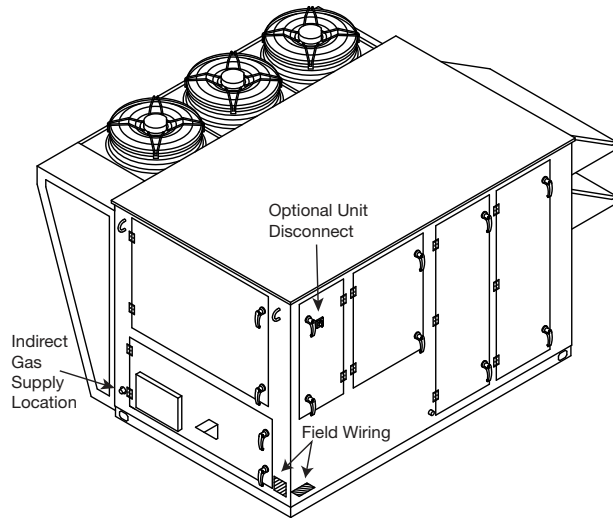

Recommended Gas and Electric Supply Entry Locations

Alternate Supply Entry Locations

Each installation is unique and as a result, alternate entry locations may be field-located. Before using any alternate entry location, verify the suitability of the location and ensure the use of an alternate location does not interfere with unit wiring, components or functionality.

Gas Connections

If this unit is equipped with an indirect gas-fired furnace, connection to an appropriate gas supply line will be required. For complete information on installation procedures for the optional gas furnace, refer the PVF/PVG Indirect Gas-Fired Heat Module Installation, Operation, and Maintenance Manual.

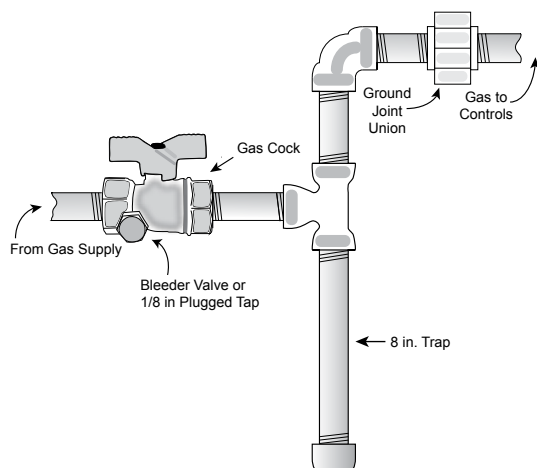

Typical Gas Supply Piping Connection

Optional Gas Piping

Units with indirect gas-fired furnaces require field-supplied and installed gas supply piping.

Housing Size	Total Heating Capacity (Input in MBH)	Gas Connection Size	Max Gas Pressure
10	75	3/4" NPT	14 in. wg.
	100		
	150		
	200		
25/35/40	100	3/4" NPT	14 in. wg.
	200		
	300		
45/65/85	300	3/4" NPT	14 in. wg.
	400		
	500		
75/150	600	3/4" NPT	14 in. wg.
	800		
	1000	1" NPT	
	1200		
110/145/180	600	1" NPT	13.5 in. wg.
	800		
	1000	2" NPT	
	1200		

WARNING

Never drill holes in the roof of the unit! There is high voltage wiring located between the inner and outer roof panels. Damage to the wiring could cause severe bodily harm or death.

NOTE

110/145/180 gas furnaces are designed for gas pressure of 5-13.5 in. wg for natural gas (6-inch minimum on single 500 and 600 MBH furnaces) and 11-13.5 in. wg for LP. If the gas pressure at the job location is greater than 13.5 in. wg, an additional regulator is required to reduce pressure. For other RV/RVE/RVC models, reference the *Model PVF and PVG IOM*.

Piping Installation

Optional Coil Piping

Factory-installed cooling and heating components are mounted in the coil section of the unit. The coil section is downstream of the energy wheel on the supply air side of the unit. Note the coil connection locations on the picture. Coil connections are located external to the unit.

Note: DX coil liquid connection is internal to units.

Water Coils

1. Piping should be in accordance with accepted industry standards. Pipework should be supported independently of the coils. When installing couplings, do not apply undue stress to the connection extending through the unit. Use a backup pipe wrench to avoid breaking the weld between coil connection and header.
2. Connect the water supply to the bottom connection on the air leaving side and the water return to the top connection on the air entering side. Connecting the supply and/or return in any other manner will result in very poor performance. Be sure to replace factory-installed grommets around coil connections if removed for piping. Failure to replace grommets will result in water leakage into the unit and altered performance.
3. Water coils are not normally recommended for use with entering air temperatures below 40°F. No control system can be depended on to be 100% safe against freeze-up with water coils. Glycol solutions or brines are the only safe media for operation of water coils with low entering air conditions. If glycol or brine solutions are not used, coils must be drained when freezing conditions are expected. **If required, vent and drain connections must be field-piped, external to the unit.**
4. Pipe sizes for the system must be selected on the basis of the head (pressure) available from the circulation pump. The velocity should not exceed 6 feet per second and the friction loss should be approximately 3 feet of water column per 100 feet of pipe.
5. For chilled water coils, the condensate drain pipe should be sized adequately to ensure the condensate drains properly. Refer to Drain Trap section.

Direct Expansion (DX) Coils (Split DX)

1. Piping should be in accordance with accepted industry standards. Pipework should be supported independently of the coils. Undue stress should not be applied at the connection to coil headers.
2. The condensate drain pipe should be sized adequately to ensure the condensate drains properly. Refer to Condensate Drain Trap section.
3. When connecting suction and liquid connections make sure the coil is free from all foreign material. Make sure all joints are tight and free of leakage. Be sure to replace factory-installed grommets around coil connections if removed for piping.
4. Manufacturer does not supply compressor, condensing units, or thermal expansion valve (TXV) with standard models. For further instruction on DX coil installation and operation contact your compressor and/or condenser manufacturer.

Condensate Drain Trap

This unit is equipped with a stainless steel condensate pan with a stainless steel connection is installed underneath the cooling coil. It is important that the condensate pan drain connection must be fitted with a P trap to ensure proper drainage of condensate while maintaining internal static pressures and to prevent migration of sewer gas back into the unit.



A P trap assembly (kit) is supplied with each unit, except for housing 110/145/180, and is to be assembled and installed as local conditions require and according to the assembly instructions provided with the P trap. If local and area codes permit, the condensate may be drained back onto the roof, but a drip pad should be provided beneath the outlet. If local and area codes require a permanent drain line, it should be fabricated and installed in accordance with Best Practices and all codes.

In some climates, it will be necessary to provide freeze protection for the P trap and drain line. The P trap should be kept filled with water or glycol solution at all times and it should be protected from freezing to protect the P trap from damage. If severe weather conditions occur, it may be necessary to fabricate a P trap and drain line of metal and install a heat tape to prevent freezing.

RVC units with polymer membrane cores include drain pans installed underneath the cores. The factory-installed drain caps should only be removed during cleaning. Do not install drain traps on the core drain pans.

Condensate Overflow Switch

This unit is equipped with an optional factory-mounted condensate overflow switch. In the event that a high level of condensate is detected, the microprocessor controller will trigger an alarm and shutdown the unit.

Electrical Information

WARNING

The roof lining contains high voltage wiring. To prevent electrocution, do not puncture the interior or exterior panels of the roof.

WARNING

To prevent injury or death due to electrocution or contact with moving parts, lock disconnect switch open. For units with a gas furnace, if you turn off the power supply, turn off the gas.

IMPORTANT

Before connecting power to the unit, read and understand the following instructions and wiring diagrams. Complete wiring diagrams are attached on the inside of the control center door(s).

IMPORTANT

All wiring should be done in accordance with the latest edition of the National Electric Code ANSI/NFPA 70 and any local codes that may apply. In Canada, wiring should be done in accordance with the Canadian Electrical Code.

IMPORTANT

The equipment must be properly grounded and bonded. Any wiring running through the unit in the airstream must be protected by metal conduit, metal clad cable or raceways.

CAUTION

If replacement wire is required, it must have a temperature rating of at least 105°C, except for an energy cut-off or sensor lead wire which must be rated to 150°C.

DANGER

High voltage electrical input is needed for this equipment. This work should be performed by a qualified electrician.

CAUTION

Any wiring deviations may result in personal injury or property damage. Manufacturer is not responsible for any damage to, or failure of the unit caused by incorrect final wiring.

Determine the Size of the Main Power Lines

The unit's nameplate states the voltage and the unit's MCA. The main power lines to the unit should be sized accordingly. The nameplate is located on the outside of the unit on the control panel side.

Determine the Size of Electric Heater Wiring

An optional electric heater may require a separate power supply. The power connection should be made to the factory-provided electric heater disconnect and must be compatible with the ratings on the nameplate, supply power voltage, phase and amperage. Consult ANSI/NFPA 70 and CSA C22.1 for proper conductor sizing.

Provide the Opening(s) for the Electrical Connections

Electrical openings vary by unit size and arrangement and are field-supplied.

Connect the Power Supplies

Connect the main power lines and electric heater power lines to the disconnect switches or terminal blocks and main grounding lug(s). Torque field connections to manufacturer's recommendations.

Wire the Optional Convenience Outlet

The convenience outlet requires a separate 115V power supply circuit. The circuit must include short circuit protection which may need to be supplied by others.

Connect Field-Wired Low Voltage Components

Most factory-supplied electrical components are prewired. To determine what electrical accessories require additional field-wiring, refer to the unit-specific wiring diagram located on the inside of the control center access door.

The low voltage control circuit is 24 VAC and control wiring should not exceed 0.75 ohms.

Control wires should not be run inside the same conduit as that carrying the supply power. Make sure that field-supplied conduit does not interfere with access panel operation. All low voltage wiring should be run in conduit wherever it may be exposed to the weather.

If wire resistance exceeds 0.75 ohms, an industrial-style, plug-in relay should be added to the unit control center and wired in place of the remote switch (typically between terminal blocks R and G on the terminal strip. The relay must be rated for at least 5 amps and have a 24 VAC coil. Failure to comply with these guidelines may cause motor starters to "chatter" or not pull in which can cause contactor failures and/or motor failures.

Field-Provided Disconnect

If field-installing an additional disconnect switch, it is recommended that there is at least four feet of service room between the switch and system access panels. When providing or replacing fuses in a fusible disconnect, use dual element time delay fuses and size according to the rating plate.

Control Center Components

Main Control Center Components

Image represents a typical installation for RVE-40 or RVE-85. Components and locations will vary on other models.

Electrical Cabinet

1. Power distribution block; high voltage supply is terminated here
2. Fuse holders
3. Phase monitor
4. Unit Disconnect
5. Condensing fan motor contactors
6. Wheel motor contactor
7. Compressor motor contactors

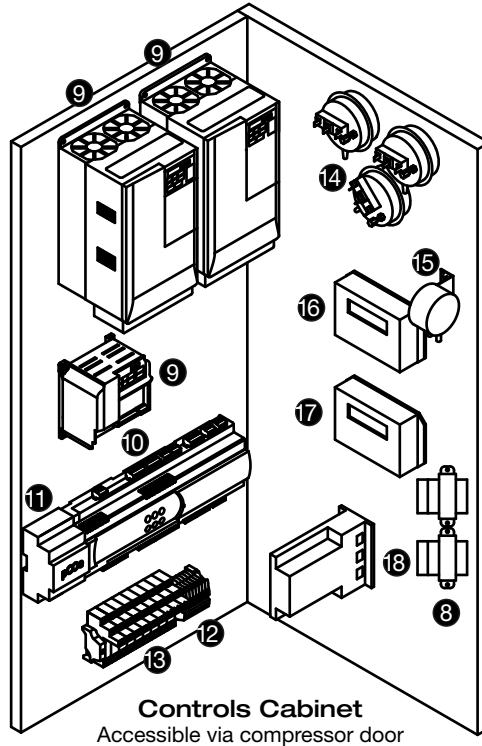

Controls Cabinet
Accessible via compressor door

Electrical Cabinet
Accessible via control center door

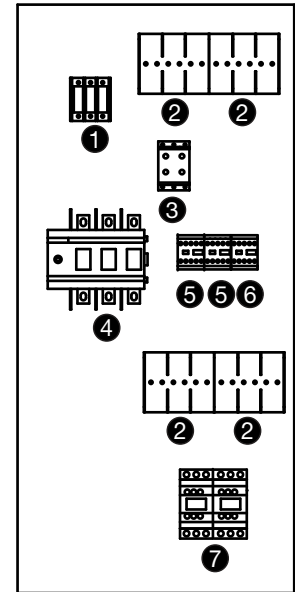

Controls Cabinet

8. Transformer
9. VFDs
10. Microprocessor controller
11. Monitoring points
12. Low voltage terminal strip
13. Relays
14. Dirty filter switches
15. Wheel pressure switch
16. Outdoor airflow monitor
17. Exhaust airflow monitor
18. Digital scroll controller

Optional Indirect Gas-Fired Furnace

Note: In some models, two furnaces are installed to provide greater output. When two furnaces are installed, they are in parallel and both will operate at the same time and the same output. Both furnaces will have identical controls.

1. Single-stage valve
2. Modulating valve
3. PCOE expansion board
4. Ignition controller
5. Transformer
6. Combustion blower
7. Burner manifold
8. Collector box

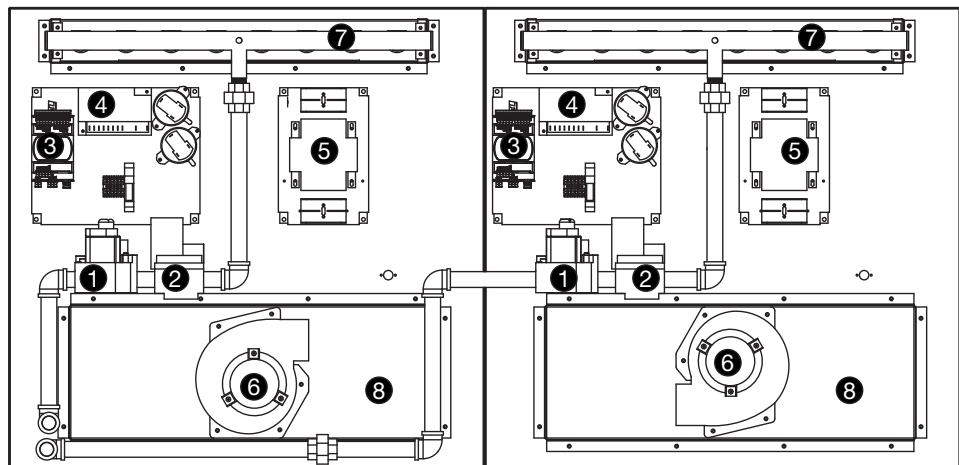

For further information on the optional furnace and its control center, see the Indirect Gas-Fired Heat IOM shipped with the unit.

Component Operation

Phase Monitor

The unit control circuitry includes a phase monitor that constantly checks for phase reversal, phase imbalance, loss of phase or a power brownout. When it detects a fault, it cuts off the 24 VAC that goes to the low voltage terminal strip, thereby shutting off all motors.

Variable Frequency Drive (VFD)

If a VFD was provided and installed at the factory, it has been pre-set to control the speed of the blower motor for optimum performance. The motor speed needs to be verified during test and balance of the unit.

If the system was configured for Constant Air Volume (CAV), the VFD will operate in an ON/OFF fashion and the speed of the motor will not change. If the system was configured for Variable Air Volume (VAV), the microprocessor will constantly monitor operating conditions and provide a signal to the VFD, changing the VFD output as needed.

The VFD may alternatively be connected to an external signal such as provided by a BMS and be operated by a 0-10 VDC input.

Supply Fan VFD Sequence

Optional Room CO₂ Sensor: The microprocessor will modulate the supply fan based on a comparison of the CO₂ set point to the actual CO₂ levels reported from the sensor. Mechanical high static protection cutoffs must be installed by others to protect the system and equipment from over-pressurization.

Optional Duct Static Pressure Sensor: The microprocessor will modulate the supply fan based on a comparison of the duct static pressure set point to the actual duct static pressure level reported from the sensor. Mechanical high static protection cutoffs must be installed by others to protect the system and equipment from over-pressurization. The manufacturer does not assume responsibility for this.

Optional Building Static Pressure Sensor: The supply fan is modulated based upon the signal from a building static pressure sensor. The microprocessor will modulate the supply fan based on a comparison of the building static pressure set point to the actual building static pressure level reported from the sensor.

Optional Single Zone VAV: The microprocessor will use a space mounted temp sensor to vary heating and cooling capacity and the airflow delivered by the fan to maintain room-air temp at a desired set point.

Optional 0-10 VDC by others to VFD: Supply fan is modulated by a 0-10 VDC, field-provided by others.

Optional Component Operation

Exhaust Fan VFD Sequence

Optional Building Static Pressure Sensor: The exhaust fan is modulated based upon the signal from a building static pressure sensor. The microprocessor will modulate the exhaust fan based upon a comparison of the building static pressure level reported from the sensor.

Optional Outdoor Air Damper Tracking: The microprocessor will proportionally modulate the exhaust fan based upon the outdoor air damper position.

Optional Supply Tracking: The microprocessor will proportionally modulate the exhaust fan based upon the supply fan.

Optional 0-10 VDC by Others to VFD: The supply fan is modulated by a 0-10 VDC provided by others in the field.

Outdoor Air and Recirculated (Recirc) Air Damper Sequence

Optional Room CO₂ Sensor: The microprocessor will proportionally modulate the OA/RA dampers based upon a comparison of the CO₂ set point to the actual CO₂ level reported from the sensor. As the CO₂ level rises, the controller will proportionally modulate the outdoor air damper open, between the minimum and maximum OA position.

Optional Building Pressure: The OA/RA dampers will modulate based upon the signal from a building static pressure sensor. The controller will modulate the dampers, between the minimum and maximum OA positions, based upon a comparison of the building static pressure set point to the actual building static pressure level reported from the sensor.

Exhaust Fan Only Power

The exhaust fan will have a dedicated power circuit where in the case of a power outage, the exhaust fan will still run. A phase monitor will detect an outage or power loss and open the contact, disconnecting all power to the unit and controller. An external signal will need to be sent to a relay to power the exhaust fan, enabling the fan to run at a maximum speed. This sequence is NOT to be used for high temperature exhaust applications.

Service Lights

Service lights provide light to each of the compartments in the energy recovery unit. The lights are wired into the service outlet receptacle on the outside of the unit. The switch to turn on the lights is located in the unit control center. The service outlet and lights require a separate power source to allow for power to the lights when the unit main disconnect is off for servicing.

Optional Component Operation

Electronically Commutated (EC) Condenser Fans with Inverter Scroll or Digital Scroll Compressors

The EC condenser fan(s) will modulate up and down to maintain the optimal liquid line pressure using built in control sequences within the factory controller. One pressure transducer is provided with each refrigeration circuit for monitoring and the factory controller will ramp condenser fan(s) up or down based on the condenser set point.

Economizer Fault Detection Diagnostics

Provides the status and faults of the air economizer to indicate proper economizer sequence operation. This assures the benefits of free cooling when outdoor conditions are suitable for economizer functions. The fault detection diagnostics system will indicate when free cooling is available and if the outside air damper and recirculation damper are reacting properly. If the dampers are not functioning correctly an alarm will be generated.

Air-Source Heat Pump

Operating Conditions and Limitations

To operate in Cooling mode, the following conditions must be true:

1. Supply air temperature above minimum low supply temperature limit (35°F)
2. Outside air temperature above the cooling ambient lockout (55°F, adj.)

To operate in Heating mode, the following conditions must be true:

1. Supply air temperature below maximum high supply temperature limit (120°F)
2. Supply air temperature above 35°F
3. Outside air temperature above the low ambient lockout (10°F, adj.)

For more information on air-source heat pump operation, reference the supplemental *Reference Guide for Microprocessor Controller*.

IMPORTANT

Air-source heat pumps are equipped with a defrost cycle to remove ice from the outdoor coil. During defrost cycles, melted water may drip from the bottom of the refrigeration section under the outdoor coil. In cold climates, proper drainage/heat tape must be installed under the outdoor coil to prevent the buildup of ice on the roof.

IMPORTANT

Melted water from snow accumulation on the unit roof can be sucked into outdoor fans, resulting in ice formation on fan blades under certain conditions. Remove snow accumulation from the unit roof and outdoor coil section after snow storms.

Airflow Monitor

IMPORTANT

For the outdoor airflow monitoring device to perform as intended, field calibration is required. Calibration of the airflow monitoring device requires an independent measurement of airflow and should be performed when the system undergoes test and balance.

A factory-wired, mounted, and powered airflow monitoring system is provided in the outdoor, supply, and/or exhaust air streams. The airflow control system displays outdoor, supply, and/or exhaust air in actual cubic feet per minute (CFM) at factory controller or can be read by a building management system if communication is established.

Operation

Outdoor airflow monitoring is accomplished using two thermal dispersion sensors that accurately measure airflow velocity down to zero feet per minute (fpm). The airflow controller takes the average measurement for two sensor configurations, and determines the outdoor airflow rate based on the effective intake area. Field calibration of the outdoor airflow monitoring device determines the effective intake area of the unit. For additional information on how to navigate through the outdoor airflow controller menus, refer to technical manuals from GreenTrol® Automation Inc. at www.greentrol.com.

Supply and/or exhaust airflow monitoring is accomplished by measuring the pressure drop across the fan inlet venture. The airflow is then calculated by the factory controller based on the measured pressure drop and a K-Factor specific for each fan size.

Hot Gas Reheat Valve

Units equipped with a reheat coil use a three-way valve with actuator to control the supply air discharge temperature of the unit during dehumidification mode. The unit controller provides a 0-10 VDC signal to control the amount of reheat to meet the supply temperature set point.

Controls by Others

The reheat coil needs to be purged to ensure adequate oil return. It is recommended that every six hours of reheat compressor run time should initiate a six minute purge cycle. During the purge cycle, the reheat valve should be modulated to 100% open to the reheat coil.

Optional Component Operation

VFD Compressor

If the VFD compressor option is included, the compressor VFD is mounted in the end of the condensing section. Condensing section internal components are accessible via the access panel on the side of the condenser coil.

Envelope Control

The unit controller tracks the operating point of the VFD compressor within the operating envelope at all times. If the operating point is out of the envelope, the controller will take action to bring it back in. If unsuccessful, the controller will shut down the compressor. DO NOT operate the compressor VFD in hand mode because the envelope control safeties will not be in place. Refer to the controls IOM for more information on envelope control.

Electronic Expansion Valve

An electronic expansion valve is provided on the VFD compressor circuit to ensure tight superheat control throughout the compressor modulation band. The EXV acts as a liquid line solenoid valve when the compressor is off to prevent refrigerant migration.

Crankcase Heat

The VFD compressor will be heated by the compressor stator. To ensure optimal performance and reliability, do not disable stator heat. All other compressors will be provided with a crankcase heater.

Oil Return Management

The compressor VFD has an oil return purge cycle such that if the compressor has been operating below a set RPM for a set period of time, the VFD will accelerate the compressor to ensure sufficient lubrication.

DO NOT disable the oil return management function.

DO NOT operate the compressor VFD in hand mode because the oil return management will not be operational.

Ultraviolet Germicidal Irradiation (UVGI)

UV-C lights are mounted downstream of the cooling coil, provide coil surface and drain pan disinfection. The lights are factory powered and are on when the supply blower is running. A kill switch on the coil access door turns the lights off when that door is open.

Needlepoint Bipolar Ionization (NPBI®)

Needlepoint bipolar ionizers are mounted on the fan inlet cone(s) and provide air disinfection. The ionizers are factory-powered and are on when there is power to the unit disconnect.

Frost Control

Extremely cold outdoor air temperatures can cause moisture condensation and frosting on the energy recovery device. Frost control is an optional feature that will prevent/control frosting.

Energy Core

Available options are:

1. Energy core bypass frost control
2. Timed exhaust frost control
3. Electric preheat frost control

Energy core bypass frost control includes a temperature sensor that is factory installed in the exhaust airstream. When the exhaust air temperature is below set point, the bypass damper modulates to maintain an exhaust air temperature set point. This sequence is included whenever a bypass damper is selected and functions independently of the additional frost control sequences listed below.

Timed exhaust frost control includes a temperature sensor that is factory installed in the exhaust airstream. When the exhaust air temperature is below set point, the supply fan turns off while the exhaust fan remains on.

Electric preheat frost control includes an electric heater (at outdoor air intake) and an outdoor air temperature sensor that is factory installed in the outdoor airstream. When the outdoor air temperature is below set point, the electric preheater energizes. Use the test procedure in the Optional Start-Up Accessories section for troubleshooting.

Polymer Energy Wheel

Available options are:

1. Timed exhaust frost control
2. Electric preheat frost control
3. Modulating wheel frost control

These options are provided with a thermodisc mounted in the outdoor air intake compartment and a pressure sensor to monitor pressure drop across the energy wheel. An outdoor air temperature below set point and an increase in pressure drop indicate that frost is occurring. Both the pressure sensor and the outdoor air thermodisc must trigger to initiate frost control. The two sensors together ensure that frost control is only initiated during a real frost condition.

Timed exhaust frost control includes a timer in addition to the thermodisc and wheel pressure sensor. When frost control is initiated, the timer will turn the supply blower off. The default timer setting will shut down the supply fan for 5 minutes every 30 minutes, allowing warm exhaust to defrost the energy wheel. Use the test procedure in the Optional Start-Up Accessories section for troubleshooting.

Optional Component Operation

Electric preheat frost control includes an electric heater (at outdoor air intake) in addition to the thermodisc and wheel pressure sensor. When frost control is initiated, the electric preheater will turn on and warm the air entering the energy wheel. Use the test procedure in the Optional Start-Up Accessories section for troubleshooting.

Modulating wheel frost control includes a variable frequency drive (VFD) in addition to the thermodisc and wheel pressure sensor. When frost control is initiated, the VFD will reduce the wheel speed, reducing effectiveness and preventing condensation and frosting. If the outdoor air temperature is greater than the frost threshold temperature **OR** the pressure differential is less than the set point, the wheel will run at full speed. If the outdoor air temperature is less than set point **AND** the pressure differential is greater than the set point, the wheel will run at reduced speed until the pressure differential falls below the set point. The VFD will be fully programmed at the factory.

Aluminum Energy Wheel

Available options are:

1. Modulating wheel frost control
2. Modulating wheel with electric preheat frost control

These options are provided with a temperature sensor mounted in the exhaust air discharge compartment. Frost control will initiate when the exhaust air temperature is below set point.

Modulating wheel frost control includes a variable frequency drive (VFD) in addition to the exhaust air temperature sensor. When frost control is initiated, the VFD will modulate the wheel speed to maintain exhaust air temperature set point. The VFD will be fully programmed at the factory.

Modulating wheel with electric preheat frost control includes a variable frequency drive (VFD) and electric heater (at outdoor air intake) in addition to the exhaust air temperature sensor. When frost control is initiated, the VFD will modulate the wheel speed to maintain exhaust air temperature set point. The electric heater will turn on when the outdoor air temperature is below set point. The VFD will be fully programmed at the factory.

Rotation Sensor

The rotation sensor monitors energy wheel rotation. If the wheel should stop rotating, the sensor will close a set of contacts in the unit control center. Field-wiring of a light (or other alarm) between terminals R and 12 in the unit control center will notify maintenance personnel when a failure has occurred.

Dirty Filter Sensor

Dirty filter sensors monitor pressure drop across the outdoor air filters, exhaust air filters, or both. If the pressure drop across the filters exceeds the set point, the sensor will close a set of contacts in the unit control center. Field-wiring of a light (or other alarm) to these contacts will notify maintenance personnel when filters need to be replaced. The switch has not been set at the factory due to external system losses that will affect the switch. This switch will need minor field adjustments after the unit has been installed with all ductwork complete. The dirty filter switch is mounted in the exhaust inlet compartment next to the unit control center or in unit control center.

Microprocessor Control

The microprocessor controller is specifically designed and programmed to optimize the performance of the unit with supplemental heating and cooling. This option ensures that the outdoor air is conditioned to the desired discharge conditions. The controller and accompanying sensors are factory-mounted, wired and programmed. Default settings are pre-programmed, but are easily field-adjustable.

The microprocessor controller can be interfaced with a Building Management System through, BACnet® or ModBus.

Please refer to the Installation, Operation and Maintenance manual for detailed information.

Unoccupied Recirculation Damper

The unoccupied recirculation option provides a recirculation damper from the return air intake to the supply airstream. If equipped with a room temperature and/or relative humidity sensor, the unit can cycle on to maintain unoccupied room set points if there is a call for unoccupied heating, cooling, or dehumidification. During the unoccupied mode, the supply and exhaust (if equipped) fans will be off unless there is a call for cooling, heating, or dehumidification in the space.

Factory-Installed Refrigeration System Components

Packaged DX Cooling with Three Way Hot Gas Reheat

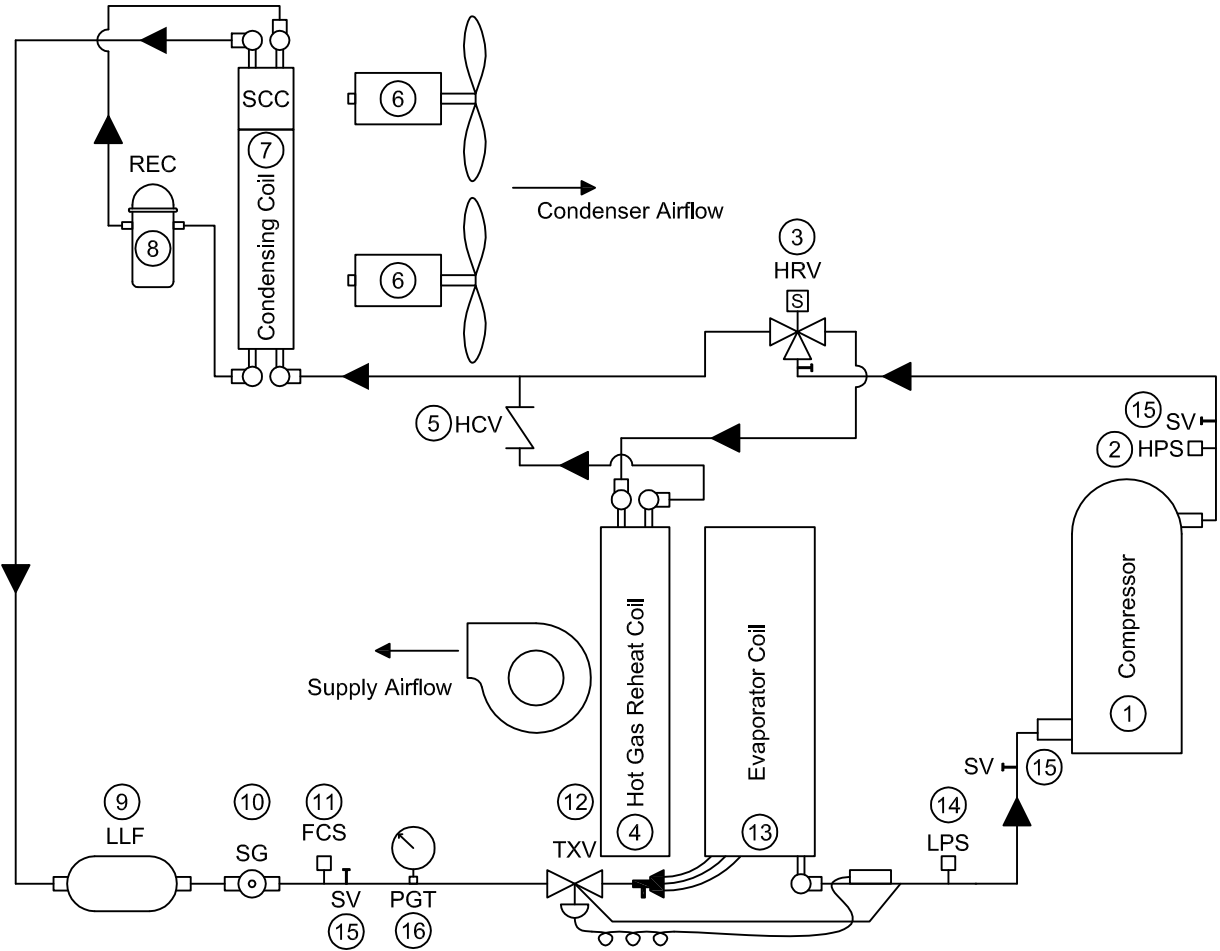

Factory-Installed Refrigeration System Components

Packaged DX Cooling with Three Way Hot Gas Reheat

1. **Compressor**
2. **High Limit Pressure Switch**

The switch opens when refrigerant pressure increases above the set point in the discharge line. A manual reset is then required.
3. **Hot Gas Reheat Valve (optional)**

Units equipped with a reheat coil use a three-way valve with actuator to control the supply air discharge temperature of the unit during dehumidification mode. The unit controller provides a 0-10 VDC signal to control the amount of reheat to meet the supply temperature set point
4. **Hot Gas Reheat Coil (Optional)**
5. **Hot Gas Reheat Check Valve (Optional)**
6. **Condenser Fans**
7. **Condensing Coil**
8. **Liquid Receiver (Optional)**
9. **Liquid Line Filter Drier**
10. **Sight Glass**
11. **Fan Cycle Switch(es)**

The switch(es) open or close based on liquid refrigerant pressure to control the condensing fans to maintain liquid pressure.
12. **Thermostatic Expansion Valve (TXV)**

Each unit is equipped with a TXV on each refrigerant circuit. The valve controls the flow of liquid refrigerant entering the evaporator coil by maintaining a constant, factory-set superheat of 10°F. The valve is adjustable and is located on the side of the evaporator coil and can be accessed through the coil access panel.
13. **Evaporative Coil**
14. **Low Limit Pressure Switch**

The switch is installed on the suction line and disables the DX system when the suction pressure drops below the set point. The switch will auto reset when the pressure rises above the auto-reset set point.
15. **Service Access Ports**
16. **Pressure Gauge & Transducer (Optional EC condenser fans only)**

See Optional Electronically Commutated (EC) Condenser Fans under the component operation.

Factory-Installed Refrigeration System Components

Air-Source Heat Pump with Three Way Hot Gas Reheat

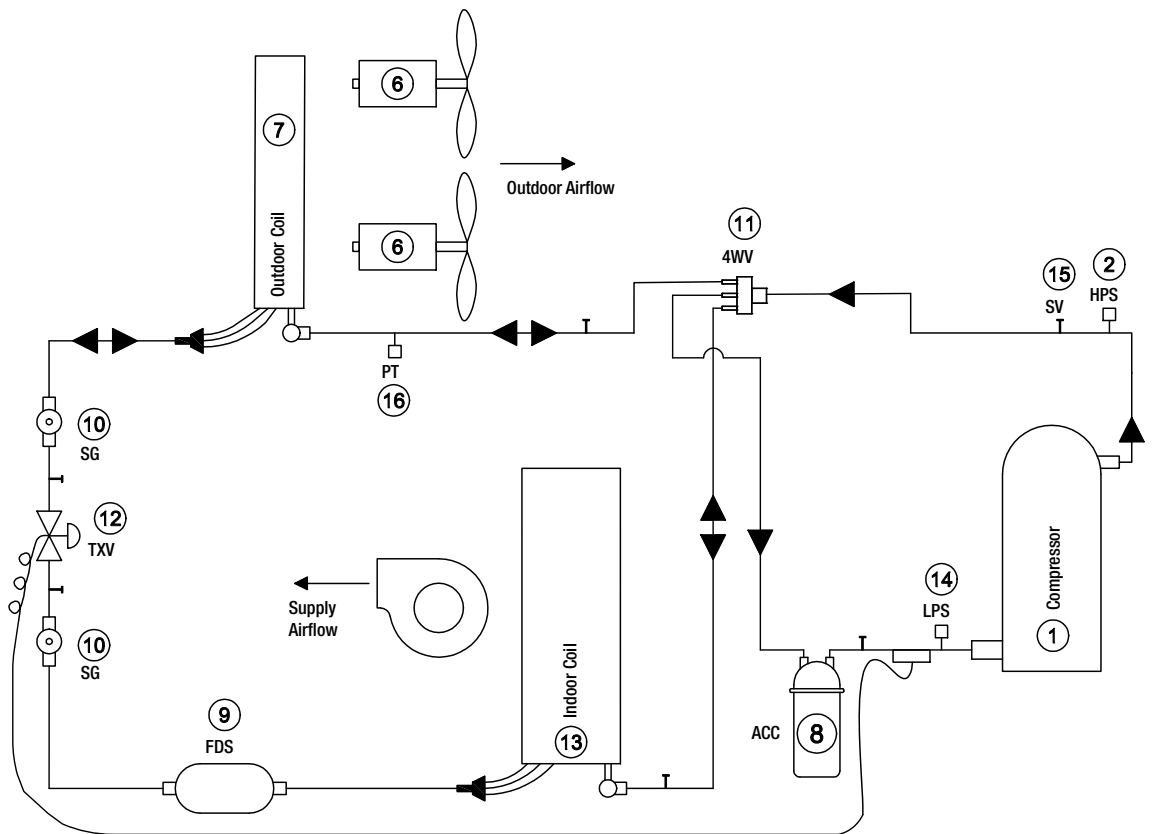
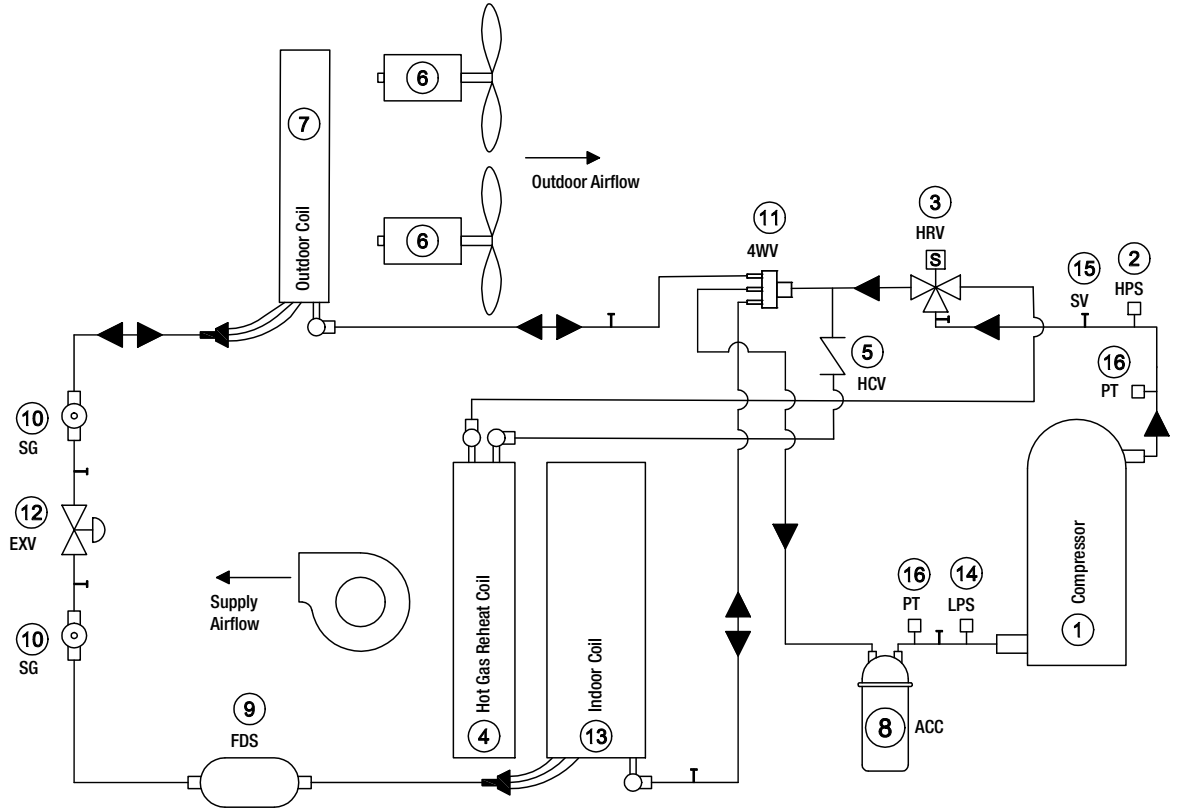

Factory-Installed Refrigeration System Components

- 1. Compressor**
- 2. High Limit Pressure Switch**

The switch opens when refrigerant pressure increases above the set point in the discharge line. A manual reset is then required.
- 3. Hot Gas Reheat Valve (optional)**

Units equipped with a reheat coil use a three-way valve with actuator to control the supply air discharge temperature of the unit during dehumidification mode. The unit controller provides a 0-10 VDC signal to control the amount of reheat to meet the supply temperature set point
- 4. Hot Gas Reheat Coil (Optional)**
- 5. Hot Gas Reheat Check Valve (Optional)**
- 6. Outdoor Fans**
- 7. Outdoor Coil**
- 8. Refrigeration Accumulator**
- 9. Liquid Line Filter Drier**
- 10. Sight Glass**
- 11. Four Way Reversing Valve**

Each compressor circuit is equipped with a reversing valve to reverse the direction of refrigerant flow, switching the unit between heating and cooling mode.
- 12. Electronic Expansion Valve (EXV) or Thermostatic Expansion Valve (TXV)**

An expansion valve is provided on each refrigerant circuit. This valve controls the flow of liquid refrigerant entering the indoor and outdoor coils by maintaining a constant superheat. The TXV is adjustable. Both the EXV and TXV are located on the side of the outdoor coil and can be accessed through the refrigeration system access panel.
- 13. Indoor Coil**
- 14. Low Limit Pressure Switch**

The switch is installed on the suction line and disables the DX system when the suction pressure drops below the set point. The switch will auto reset when the pressure rises above the auto-reset set point.
- 15. Service Access Ports**

Typical port locations are shown. Additional valves may be present in the system.
- 16. Refrigerant Pressure Transducers**

Start-Up Components

Fan

The fan should be checked for free rotation. If any binding occurs, check for concealed damage and foreign objects in the fan housing.

CAUTION

When operating conditions of the fan are to be changed (speed, pressure, temperature, etc.), consult manufacturer to determine if the unit can operate safely at the new conditions.

Supply Fan (Plenum Type)

The unit contains one or two plenum supply fans located on the end of the unit opposite the outdoor air intake and may optionally have a relief air blower which is referred to as an exhaust blower in this document. Efficient fan performance can be maintained by having the correct offset.

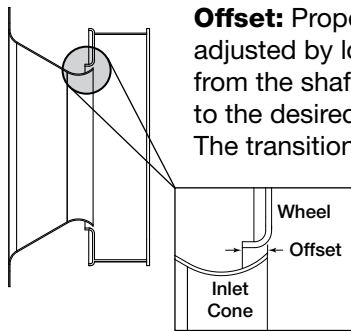

Offset: Proper offset, or overlap, is adjusted by loosening the wheel hub from the shaft and moving the wheel to the desired position along the shaft. The transition between the inlet cone and the wheel should be as shown; there is a smooth feel to the profile when moving one component to the other.

Fan Size	Offset (inches)	Tolerance (inches)
ER35C	5/32	± 1/32
ER45C	3/16	± 1/32
ER50C	13/64	± 1/32
ER56C	1/4	± 1/32
PDL-355	5/32	± 1/32
PRM-450	3/16	± 1/32
PRM-560	15/64	± 1/32

Refer to the respective Installation, Operation and Maintenance Manual shipped with this unit for additional start-up and maintenance information regarding the plenum fan.

Fan Wheel Rotation Direction

Check for proper wheel rotation by momentarily energizing the fan. Rotation is determined by viewing the wheel from the drive side and should match the rotation decal affixed to the fan housing.

If the wheel is rotating the wrong way, direction can be reversed by interchanging any two of the three electrical leads. Check for unusual noise, vibration or overheating of the bearings. Refer to the Troubleshooting portion of this manual if a problem develops.

Supply/Exhaust Fan

The optional exhaust fan is a direct-drive plenum type. Fan speed is controlled by a VFD which, in turn, is controlled by the microprocessor controller or by an external signal. Motor speed will be set on the VFD during the unit Test and Balance, but after that, the VFD will not normally be changed. Always check the motor amperage rating shown on the motor nameplate when changing the fan RPM. All access doors must be installed except the control center door.

Vibration

Vibration Causes

- Off axis or loose components
- Drive component unbalance
- Poor inlet / outlet conditions
- Foundation stiffness

Excessive vibration may be experienced during initial start-up. Left unchecked, excessive vibration can cause a multitude of problems,

including structural and/or component failure. The most common sources of vibration are listed.

Many of these conditions can be discovered by careful observation. Refer to the Troubleshooting section of this manual for corrective actions. If observation cannot locate the source of vibration, a qualified technician using vibration analysis equipment should be consulted.

Generally, fan vibration and noise is transmitted to other parts of the building by the ductwork. To eliminate this undesirable effect, the use of flexible connectors is recommended.

Discharge Air Temperature Sensor

Units are supplied with a Discharge Air Temperature Sensor that is to be field-installed prior to unit start-up. The sensor is to be installed at least three duct diameters downstream of the heat exchanger. The sensor must be connected directly to the microprocessor controller. All other sensors and low voltage devices are to be connected to the low voltage terminal strip in the control center. The discharge air sensor is shipped loose and can be found in the unit's control center. See the unit-specific wiring diagram for connection locations.



Typical Discharge Air Temperature Sensor

Start-up Components

Airflow Monitoring

For additional information on how to navigate through the airflow controller menus, refer to technical manuals from GreenTrol® Automation Inc. at www.greentrol.com. Also refer to the Greenheck Reference Guide for Microprocessor Controller.

Display and Navigation

The LCD screen will by default show the current airflow that is being measured. To enter the menu to set up the monitoring station the user must remove the front cover of the GreenTrol to uncover the navigation buttons. Press and hold the UP and DOWN keys at the same time for 3 seconds to enter the menu.

Enter Button Function - The ENTER button allows the user to go into the selected menu or function, as well as save the selected value.

Up/Down Button Function - The UP/DOWN buttons are used to navigate the menu and to change values in the menu.

Esc Button Function - The ESC button allows the user to exit the current menu or function.

Field Calibration

1. Press UP/DOWN = Setup
2. Press DOWN/ENTER = Setup Wizard
3. Scroll Down to Field Adjust and press ENTER
4. Run FAK wizard and press ENTER
5. Set FAW Int and press ENTER
6. FAW INT = 300 and press ENTER
7. Set number of flows and press ENTER
8. Set flow and press ENTER
9. Set flow to actual CFM measured by Test and Balance and press ENTER
10. Wait for calibration before cycling power
11. Proceed to Communication Setup

Communication Setup

1. Press the UP and DOWN keys at the same time for 3 seconds
2. When SETUP appears on the screen press ENTER
3. Scroll DOWN (twice) to the NETWORK menu and press ENTER
4. When NETOUT appears on the screen, press ENTER; when SET NETOUT appears on the screen, press ENTER again
5. Scroll UP or DOWN to set the NETOUT = MODBUS and then press ENTER
6. Scroll DOWN to NETADDR and press ENTER, when SET NETADDR appears on the screen press ENTER again
7. Scroll UP or DOWN to set the NETADDR to the same address that was listed for the airflow monitor in the microprocessor. For instance, the Outdoor Airflow Monitor screen above has an address of 31. Then press ENTER.
8. Scroll DOWN to NETBAUD and press ENTER, when SET NETBAUD appears on the screen, press ENTER again
9. Scroll UP or DOWN until NETBAUD = 19200, then press ENTER
10. Scroll down to PARITY and press ENTER, when SET PARITY appears on the screen press ENTER again
11. Scroll UP or DOWN until PARITY = NONE2, then press ENTER
12. Once the address is set and the communication wires are connected, "Status" LED should be a steady green and the "RS485" LED should be a quick blinking green LED.

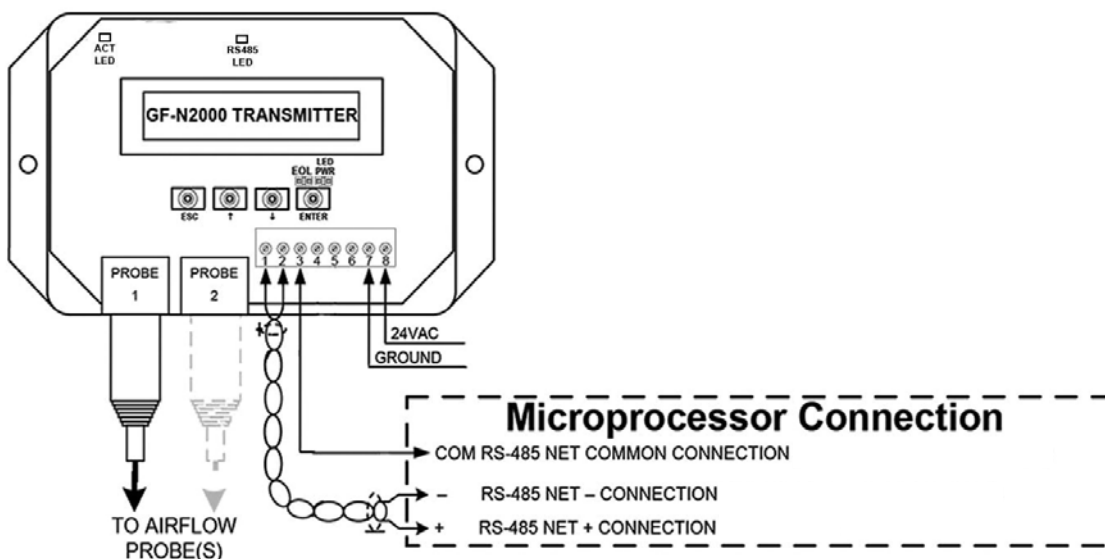

Start-up Components

Optional Dirty Filter Switch

To adjust the switch, the unit must be running with all of the access doors in place, except for the compartment where the switch is located (exhaust intake compartment). The adjusting screw is located on the top of the switch.

1. Open the filter compartment and place a sheet of plastic or cardboard over 50% of the filter media.

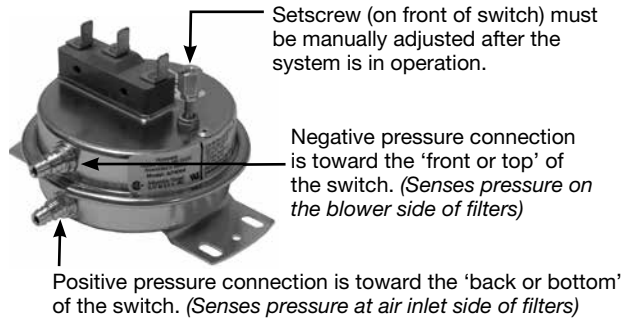

2. Replace the filter compartment door.
3. Check to see if there is power at the alert signal leads (refer to electrical diagram).
4. Whether there is power or not, turn the adjustment screw on the dirty filter gauge (clockwise if you did not have power, counterclockwise if you did have power) until the power comes on or just before the power goes off.
5. Open the filter compartment and remove the obstructing material.
6. Replace the door and check to make sure that you do **not** have power at the alert signal leads. The unit is now ready for operation.

Optional Polymer Energy Wheel

Start-Up

If selected, the energy wheel is installed in the unit with one half of the wheel in the outdoor airstream and one half in the exhaust airstream. The energy wheel includes air seals to minimize leakage between airstreams.

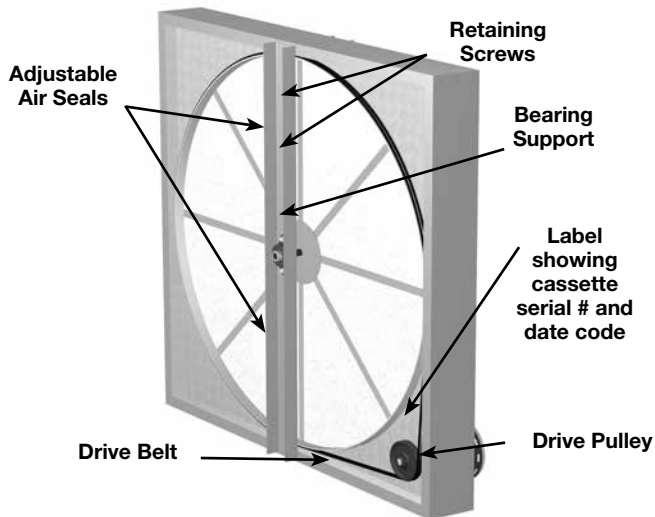

Drive Belt

Inspect the drive belt. Make sure the belt rides smoothly in the pulley and around the outside of the wheel. Note the directional arrow and data information shown in the image.

Adjust the Air Seals (Polymer wheels only)

The information below only applies to polymer wheels, which require air seal adjustment at the time of start-up for proper performance. Aluminum wheel air seals are factory-set and do not require field adjustment.

Make sure the unit power supply is locked out. Disconnect the wiring to the wheel module and pull the wheel cassette out of the cabinet on its tracks. Large cassettes are not removable. Then slowly rotate the wheel by hand to make sure there is no binding or misalignment.

There is a perimeter seal located around the outside of the wheel and a diameter seal across the face of the wheel on both sides. Check to make sure that all air seals are secure and in good condition.

Adjust the air seals by loosening all the air seal retaining screws on the bearing support. Using a piece of paper as a feeler gauge, adjust the seals so they almost touch the face of the wheel while tugging slightly on the paper. When the wheel is rotated, there should be a slight tug on the paper. Tighten the screws, repeat the steps on the other set of seals.

Push the wheel cassette back into the unit and plug in the power connector. Turn the main power supply back on and then observe the operation of the wheel by opening the wheel access door slightly. Remove filters if necessary to observe the wheel.

Sequence of Operation

Optional Economizer - The economizer will be locked out when: the outside air is below economizer lockout; the unit is operating in dehumidification mode; or there is a call for heating.

- **Stop Wheel:** When economizer mode is enabled and there is a signal for cooling, the wheel will stop rotating to allow free cooling.
- **Modulate Wheel:** When economizer mode is enabled and there is a signal for cooling, the wheel VFD modulates wheel speed to maintain the discharge temperature set point.

Optional Frost Control

The microprocessor controller will output a signal when wheel frosting is occurring which is determined by a temperature set point and wheel pressure drop increase.

- **Preheat:** When frosting is occurring, the preheater is energized to defrost the wheel. Once the pressure drop decreases below the set point, the preheater is de-energized.
- **Timed Exhaust:** When frosting is occurring, the supply blower is cycled off. The exhaust blower shall continue to run, allowing the warm exhaust air to defrost the wheel. After the 5 minute cycle, the supply fan is re-energized to continue normal operation.
- **Modulating Wheel:** When frosting is occurring, the wheel VFD will reduce wheel speed to prevent condensation and frosting. If the outdoor air temperature is greater than the frost threshold temperature OR the pressure differential is less than the set point, the wheel will run at full speed. If the outdoor air temperature is less than the frost threshold temperature AND the pressure differential is greater than the set point, the wheel will run at reduced speed until the pressure differential falls below the set point. The temperature and pressure differential set points are set at the factory, but are field-adjustable. The VFD will be fully programmed at the factory.

Optional Polymer Energy Wheel

Maintenance

WARNING

Whenever performing maintenance or inspections, always disconnect the power source.

Inspection

The wheel should be inspected semiannually in accordance with the maintenance schedule. Maintenance of the wheel consists mainly of inspecting the wheel for cleanliness and then checking the drive motor, belt, and pulley for wear. If the wheel appears dirty, the wheel should be disassembled and cleaned.

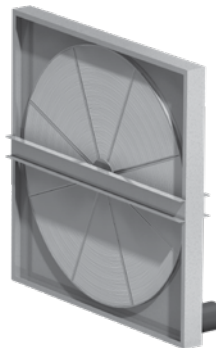

Energy Wheel Cassette

The wheel rotates through two airstreams moving in opposite directions, which means the wheel is self-cleaning, up to a point. If the wheel media becomes blocked by dirt or dust, or if the media collects a layer of smoke residue or an oily film, the energy transfer efficiency drops.

The main factor in the frequency of cleaning is the cleanliness of the air. If air filters are not changed frequently, the wheel will collect contaminants and will then have to be cleaned.

Wheel Disassembly

Wheels are part of a cassette that may be pulled from the unit for easy access. There may be a small damper assembly or other component that blocks removal of the cassette. Before sliding out the cassette or any other component, disconnect any power supply cord and secure it so it cannot jam or otherwise get damaged.

Each wheel has removable segments that hold the coated layers of media and each segment is held in place with two retaining clips located on the outer rim of the wheel. When removing more than one segment, remove them in sequence from opposite sides of the wheel (180 degrees apart) to reduce the imbalance. Secure the wheel against rotation. Carefully release the two retaining clips and swing them fully open. The segment can now be removed by pushing the face of the segment close to the outer rim of the wheel. Wheel segments are built to close tolerances and the segment may have to be jiggled to remove it. Do not use a hammer or otherwise force the segment because these are high value items and are not built to withstand abuse.



Segment Retaining Clip

Whenever retaining clips are opened, they should be closed as soon as possible. If the wheel should rotate when a clip is open, the clip will jam against the bearing support bar and could cause damage.

Cleaning

Maintenance or cleaning of the wheel segments should be done with the segments removed from the wheel cassette to avoid splashing liquids or cleaning agents inside the cabinet. If the energy wheel appears excessively dirty, it should be cleaned to ensure maximum operating efficiency. Only excessive buildup of foreign materials needs to be removed.

DISCOLORATION AND STAINING OF ENERGY RECOVERY WHEEL DOES NOT AFFECT ITS PERFORMANCE.

Thoroughly spray the wheel matrix with a household cleaner such as Fantastik™ or the equivalent. Gently rinse with warm water and use a soft brush to remove any heavy accumulations. A detergent/water solution can also be used. Avoid aggressive organic solvents, such as acetone. Wheel segments can be soaked in the above solution overnight for removal of stubborn dirt or accumulations.

After cleaning is complete, shake excess water from the wheel or segments. Dry the wheel or segments before putting them back into the cassette.

Reassembly

When reinstalling the segments, be sure to install them with the correct face toward the motor side of the cassette. Note that one face of each segment is smooth and the other face has a reinforcing channel or support cut into the surface.



Wheel Segment (Pulley Side)

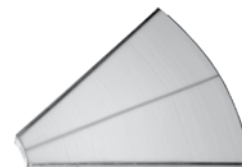

Wheel Segment (Motor Side)

Wheel Belt

Inspect belts each time filters are replaced. Belts that look chewed up or are leaving belt dust near the motor pulley may indicate a problem with the wheel. Be sure to inspect wheel for smooth and unrestricted rotation. If a belt requires replacement, contact the local manufacturer representative. Instructions for replacement will ship with the new belt.

Wheel Bearing

In the unlikely event that a wheel bearing fails, the bearing is behind a removable plate on the wheel support beam (slide cassette halfway out of cabinet to access). Contact the local manufacturer's representative for detailed instructions on how to replace the bearing.

Optional Aluminum Energy Wheel

Sequence of Operation

Optional Economizer

The economizer will be locked out when: the outside air is below economizer lockout; the unit is operating in dehumidification mode; or there is a call for heating.

- **Modulate Wheel:** When economizer mode is enabled and there is a signal for cooling, the wheel VFD modulates wheel speed to maintain the discharge temperature set point.

Optional Frost Control

The microprocessor controller will output a signal when wheel frosting is occurring which is determined by a temperature set point.

- **Modulating Wheel:** When frosting is occurring, the wheel VFD will modulate the wheel speed to maintain an exhaust air temperature set point. The VFD will be fully programmed at the factory.
- **Modulating Wheel with Electric Preheat:** When frosting is occurring, the wheel VFD will modulate the wheel speed to maintain a set point exhaust air temperature set point. The electric preheater will energize when the outdoor air temperature is below set point. The VFD will be fully programmed at the factory.

Maintenance

WARNING

Whenever performing maintenance or inspections, always disconnect the power source.

Inspection

The wheel should be inspected in accordance with the maintenance schedule. Maintenance of the wheel consists mainly of inspecting the wheel for cleanliness and then checking the drive motor, belt, and pulley for wear. If the wheel appears dirty, the wheel should be cleaned.

The wheel rotates through two airstreams moving in opposite directions, which means the wheel is self-cleaning up to a point. If the wheel media collects a layer of smoke residue or an oil film, the energy transfer efficiency drops.

The main factor in the frequency of cleaning is the cleanliness of the air. If air filters are not changed frequently, the wheel will collect contaminants and will then have to be cleaned.

Cleaning

Accumulation of dust or particles on the surface of the wheel can typically be vacuumed, purged with compressed air, or wiped from the surface. In cases when a more thorough cleaning is required, use the following procedure.

Liberally spray 409 cleaner onto a small section of the dirty side of the energy wheel, letting it foam to soften debris and residue. Blow approximately 90 psi of compressed air and from the opposite side of the wheel, catching the blown-off material on pre-placed drop cloths. Lightly sweep a soft sash paint brush across the face of the wheel to remove any leftover residue. A SLIGHT CLEANER SMELL MAY BE PRESENT FOR A SHORT TIME AFTER THE UNIT IS TURNED BACK ON. THIS SMELL WILL DISSIPATE QUICKLY.

Wheel Belt

Inspect belts each time filters are replaced. Belts that look chewed up or are leaving belt dust near the motor pulley may indicate a problem with the wheel. Be sure to inspect wheel for smooth and unrestricted rotation. If a belt requires replacement, contact the local manufacturer representative. Instructions for replacement will ship with the new belt.

Wheel Bearing

In the unlikely event that a wheel bearing fails, contact the local manufacturer's representative for detailed instructions.

Troubleshooting - Optional Energy Wheel

Symptom	Possible Cause	Corrective Action
Energy wheel does NOT turn	Air seals are too tight.	Refer to Adjust the Air Seals in the Optional Energy Wheel Start-Up section.
	Broken belt.	Replace.
	No power to wheel motor.	Make sure wheel drive is plugged in. Verify power is available.
Energy wheel runs intermittently	Wheel motor overloads are tripping due to rubbing between wheel and air seals.	Recheck air seals, make sure they are not too tight. See Adjust the Air Seals in the Optional Energy Wheel Start-Up section.

Optional Energy Core

WARNING

Energy core shall not be subjected to temperatures greater than 140°F. RVC-35 and RVC-65 models shall not be subjected to temperatures less than -40°F; and RVC-145 models shall not be subjected to temperatures less than -20°F. This will result in a damaged core and will not be covered by warranty.

WARNING

Running a single fan location when there is a high moisture content in the air moving through an energy core may result in damage to the fiber energy core. While this scenario (example: supply fan on, exhaust fan off) would not happen during normal operation with our microprocessor controls, it is advised against manually overriding a unit to run in this manner. Any damage resulting from this condition will not be covered by warranty.

Sequence of Operation

Optional Economizer

The economizer will be locked out when: the outside air is below economizer lockout; the unit is operating in dehumidification mode; or there is a call for heating.

- **Energy Core Bypass:** When economizer mode is enabled and there is a signal for cooling, the energy core bypass damper opens to bypass outdoor air around the core.

Optional Frost Control

The microprocessor controller will output a signal when core frosting is occurring.

- **Energy Core Bypass:** When the exhaust air temperature is below set point, the bypass damper modulates to maintain an exhaust air temperature set point. This sequence is included whenever a bypass damper is selected and functions independently of the additional frost control sequences listed below.
- **Timed Exhaust:** When the exhaust air temperature is below set point, the supply fan turns off while the exhaust fan remains on.
- **Preheat:** When the outdoor air temperature is below set point, the electric preheater energizes.

Maintenance

WARNING

Whenever performing maintenance or inspections, always disconnect the power source.

Inspection

A regular cleaning cycle must be established for the energy core to maintain optimum performance. In reasonably clean environments such as schools, offices

or retail stores, the energy core should be inspected annually and cleaned as needed. Failure to follow a regular cleaning cycle for the energy core can result in significant energy transfer performance losses.

Cleaning

Energy cores do not require removal to be cleaned.



Washing Fiber Membrane Core

Fiber Membrane Core

Gently vacuum the surfaces of the energy core to remove the dirt and debris that has accumulated.

WARNING

Do not wash, soak in water, or use detergents and/or cleaners on the fiber membrane core. This will result in a damaged core and will not be covered by the warranty.

Polymer Membrane Core

Use low pressure tap water to clean the energy core. A drain pan is installed underneath the core to collect waste water. Remove the factory-installed drain caps prior to cleaning. If the core is extremely dirty, use a mild detergent such as Dawn® in a solution no less than 1:100 parts soap to water, and then rinse with tap water until no more bubbles appear.

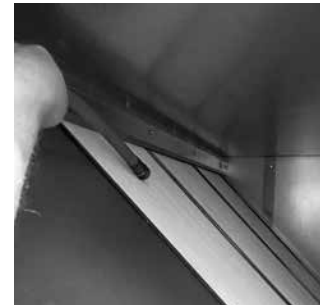

Washing Polymer Membrane Core

WARNING

Do not use a high pressure water source (pressure washer) or harsh, corrosive detergents. This will result in a damaged core and will not be covered by the warranty.

Troubleshooting – Alarms

Several of the electronic controls in the unit monitor the system for faults and will go into alarm, shutting down the unit or a single function within the unit.

Microprocessor Controller

The microprocessor is located in the main control center. If the microprocessor is in alarm condition, the Alarm button will blink red. Press the Alarm button to see the specific condition or to reset the microprocessor. Refer to the microprocessor IOM for detailed information on fault codes and see the unit-specific wiring diagram.

Phase Monitor

The phase monitor has two LED indicator lights, one red and one green. Green indicates proper operational status, red indicates the unit has detected a fault and is in alarm condition. The alarm LED will blink to show the specific fault and there is a chart printed on the monitor that shows the code for the blinking light. The phase monitor is self-resetting once the alarm condition is corrected. It is located in the main control center.

Variable Frequency Drive (VFD)

Variable frequency drives have a display screen that will show an alarm condition. If a fault such as a voltage spike occurs, the VFD will go into alarm and will not reset until a hard restart is performed. See the unit-specific manufacturer's manual supplied with the unit. VFDs are located in the main control center.

Optional Digital Scroll Compressor Controller

Present only if packaged DX with digital scroll option is selected. The controller has three LED indicator lights.

One is green, indicating that it has power, one is an alarm indicator that will flash a code for various alarm conditions and the third indicates whether the compressor is operating in a loaded or unloaded condition. See the manufacturer's unit-specific manual for further information.



See the Fault Code chart below. The Fault Code chart is also printed on the back of the controller. Note that if the controller generates either a Code 2 or a Code 4 Lockout, a manual reset must be performed. Manual Reset is accomplished by shutting off main power to the unit and then turning it back on.

Digital Scroll Compressor Controller Fault Codes			
Alert Code	System Condition	Diagnostic Alert Light	Action
Code 2*	High Discharge Temperature Trip	Blinks 2 Times	Lockout
Code 3	Compressor Protector Trip	Blinks 3 Times	Lockout
Code 4*	Locked Rotor	Blinks 4 Times	Lockout
Code 5	Demand Signal Loss	Blinks 5 Times	Lockout
Code 6	Discharge Thermistor Fault	Blinks 6 Times	Reduce Capacity
Code 7	Future	N/A	N/A
Code 8	Welded Contactor	Blinks 8 Times	Unload Compressor
Code 9	Low Voltage	Blinks 9 Times	Trip Compressor

*Protective faults that require manual reset.

Troubleshooting – Unit

Symptom	Possible Cause	Corrective Action
Blower fails to operate	Blown fuse or open circuit breaker.	Replace fuse or reset circuit breaker and check amps.
	Defective motor or capacitor.	Replace.
	Motor overloaded.	Reset VFD and check amps.
	Electrical.	Check for On/Off switches. Check for correct supply voltage. Check Control wiring.
Motor starters “chatter” or do not pull in	Control power (24 VAC) wiring run is too long. (Resistance should not exceed 0.75 ohms).	Shorten wiring run to mechanical room or install a relay to turn unit on/off. Consult factory for relay information. Increase wire gauge size so that resistance is 0.75 ohms or less.
	Incoming supply power is less than anticipated. Voltage supplied to starter coil must be within +10% / -15% of nominal voltage stated on the coil.	Need to increase supply power or use a special control transformer which is sized for the actual supply power.
Motor over amps	Static pressures are higher than design.	Check for dirty filters. Improve ductwork.
	Motor voltage incorrect.	Check motor wiring. Check motor nameplate versus supplied voltage.
	Motor horsepower too low.	See specifications and catalog for fan curves to determine if horsepower is sufficient.
	Shorted windings in motor.	Replace motor.
Low airflow (cfm)	Unit damper not fully open.	Adjust damper linkage or replace damper motor.
	System static pressure too high.	Improve ductwork to eliminate losses using good duct practices.
	Blower speed too low.	Check maximum motor RPM and compare with catalog data. Verify that external control wiring is in place if required.
	Fan wheels are operating backwards.	For 3-phase, see Direction of Fan Wheel Rotation Direction in Start-Up, Components section.
	Dirty filter.	Replace filters or follow cleaning procedures in Routine Maintenance section of this manual.
	Leaks in ductwork.	Repair.
High airflow (cfm)	Blower fan speed too high.	Check for correct maximum fan RPM. Decrease maximum fan speed if necessary in the VFD.
	Filter(s) not in place.	Install filters.
	Insufficient static pressure (Ps). (airflow resistance)	Induce Ps into system ductwork. Make sure grilles and access doors are installed. Decrease fan speed if necessary.
	Elbows or other obstructions may be obstructing fan outlet.	Correct or improve ductwork.
Excessive noise or vibration	Fan wheel rubbing on inlet.	Adjust wheel and/or inlet cone. Tighten wheel hub or bearing collars on shaft.
	Bearings.	Replace defective bearing(s). Lubricate bearings. Tighten collars and fasteners.
	Loose wheel on shaft.	Tighten wheel hub.
	Motor base or blower loose.	Tighten mounting bolts.
	Noise being transmitted by duct.	Make sure ductwork is supported properly. Make sure ductwork metal thickness is sized for proper stiffness. Check duct size at discharge to ensure that air velocities are not too high.

Always have a completed Pre-Start-Up Checklist and Start-Up Checklist prior to requesting parts or service information.

Troubleshooting – Refrigeration Circuit

TROUBLESHOOTING NOTE

Before any components are changed on the refrigeration system, the cause of the failure must be identified. Further problems will exist unless the true cause or problem is identified and corrected.

IMPORTANT

Do not release refrigerant to the atmosphere! If required service procedures include the adding or removing of refrigerant, the service technician must comply with all federal, state and local laws. The procedures discussed in this manual should only be performed by a qualified EPA Certified Technician.

NOTE: Unit is equipped with a phase loss/phase reversal control. If system does not start, check phase of electrical supply.

The first step in troubleshooting a refrigeration circuit is to examine the microprocessor controller and digital scroll compressor controller (if present) and see if there is a fault code. The next step is to check airflow conditions (e.g. improper ductwork, atypical wet bulb / dry bulb, etc.). After these steps have been eliminated, proceed with troubleshooting by following this guide.

Symptom	Possible Cause	Corrective Action
Compressor will not run or does not start	Open disconnect switch or circuit breaker.	Close switch and/or breaker.
	Compressor contactor not closing.	Check voltage to contactor coil, transformer, slave relay, system. Replace parts as necessary.
	Blown fuse or tripped breaker.	Check for reason and repair. Replace fuse after correcting problem.
	Low line voltage.	Check line voltage. If more than 10% from compressor marking, correcting is necessary.
	Compressor motor protector open.	Motor thermal protector automatically resets. Allow time (2 hours) for compressor to cool down so protector will reset. Restart and check for reason overheat occurred.
	Compressor defective.	Check motor for open circuit, short circuit, grounded windings, or burn out. Compressor may be seized; check refrigerant. If necessary, replace compressor.
	High pressure switch open or defective.	If manual reset (high pressure), reset switch. (Switch opens at 610 psi and will not reset above 420 psi for R-410A). Replace if defective.
	Low pressure switch open or defective.	See switch label for setpoint.
	Open room thermostat or control. (No cooling required).	Check room temperature. If temperature is proper, wait for thermostat to close.
Loose wiring.	Check all wire terminals and tighten as necessary.	
Compressor starts but cuts out on low pressure <i>Low pressure switch cuts out at 50 PSIG (PDX) or 25 PSIG (ASHP)</i>	Low or loss of refrigerant charge.	Check refrigerant pressures and temperatures (subcooling.)
	Airflow restricted.	Check for dirty evaporator coil, dirty filters, dampers closed, iced evaporator coil, improper belt, check motor amps, check duct design.
	Restriction in refrigerant line.	Check refrigerant pressures, look for frosted tubing and components indicating a restriction. Check pressure drop across the filter drier.
	Defective low pressure switch.	Replace.

Always have a completed Pre-Start-Up Checklist and Start-Up Checklist prior to requesting parts or service information.

Troubleshooting – Refrigeration Circuit

Symptom	Possible Cause	Corrective Action
Compressor starts but cuts out on high pressure switch <i>High pressure switch cuts out at 610 PSIG</i>	Refrigerant overcharge.	Check pressures, charge by subcooling.
	Condenser fan motor defective.	Check fan motor.
	Condenser coil inlet obstructed or dirty.	Check coil and clearances. Clean coil if necessary.
	Air or non-condensables in system.	Check high side equalized pressures, check expansion valves.
	Defective high pressure switch.	Replace.
	Restriction in discharge or liquid line.	Check refrigerant line pressures, check expansion valves, replace any defective component.
	Condensing fan relay not pulling in.	Replace.
Compressor cuts out on thermal overload	Low voltage.	Check voltage.
	Sustained high discharge pressure.	Check running amperage and conditions described under “low suction pressure” symptoms.
	High suction and discharge pressures.	Check thermal expansion valve setting, check for air in system. Check air conditions and cfm.
	Defective compressor overload.	If compressor is hot, allow compressor to cool for two hours. Recheck for open circuit.
	Improper refrigerant charge.	Check subcooling.
	Improperly wired.	Review wiring schematics.
	Loose wiring.	Check all connections.
	Defective start relay.	Replace relay.
	Motor windings damaged.	Verify amp draw.
Compressor hums, but will not start	Improperly wired.	Review wiring schematics.
	Low line voltage.	Check voltage.
	Loose wiring.	Check all connections.
	Defective start relay.	Replace relay.
	Motor winding damaged.	Verify amp draws. Replace compressor if necessary.
	Internal compressor mechanical damage.	Replace.
Compressor noisy or vibrating	Refrigerant overcharge.	Check pressures and subcooling.
	Liquid floodback.	Check thermal expansion valve setting. Check for refrigerant overcharge.
	Tubing rattle.	Dampen tubing vibration by taping or clamping. Carefully bend tubing away from contact where possible.
	Scroll compressor rotating in reverse. (3-phase)	Check high and low side pressures during operation to confirm. Rewire for opposite rotation.
	Damaged compressor.	Replace the compressor.
	Improper mounting on unit base.	Check that compressor is properly isolated and mounting bolts are tight.

Always have a completed Pre-Start-Up Checklist and Start-Up Checklist prior to requesting parts or service information.

Troubleshooting – Refrigeration Circuit

Symptom	Possible Cause	Corrective Action
High suction pressure	Excessive load on evaporator coil.	Check for high entering wet bulb temperature, check for excessive air flow.
	Compressor is unloaded. (digital scroll)	Check digital scroll controller signal and solenoid valve.
	Expansion valve sensing bulb not secured to suction line.	Check the thermal expansion valve, ensure bulb is insulated. Check superheat. If superheat is high, then valve is choking refrigerant flow. <ul style="list-style-type: none"> • Check bulb for contact. • Adjust valve for superheat ~10°F. • Replace valve powerhead or valve.
	Thermostatic expansion valve. Overfeeding.	Check bulb location and clamping. Adjust superheat. Replace expansion valve power head.
	Room load too large.	Reduce the load or add more equipment.
	Overcharged.	Check pressures and subcooling.
High discharge pressure	Thermal expansion valve setting.	Check thermal expansion setting and calibrate superheat / subcooling.
	Air inlet to condenser coil dirty or obstructed.	Check for proper clearances and possible air recirculating. Clean coil.
	Condenser fan motor defective.	Check condenser fan motor.
	Too much refrigerant.	Check subcooling. Remove excess refrigerant.
	Non-condensable in system.	Remove non-condensable from system.
	Dirty condenser coil.	Clean condenser coil.
	Condenser fan not running or running backwards.	Check electrical circuit and fuse. Check fan cycling controls.
High load conditions.	Add more equipment or reduce load.	
Low suction pressure	Refrigerant undercharge/loss of refrigerant charge.	Check pressures and subcooling.
	Blower running backward.	Confirm blower rotation. If reversed, interchange any two wires from 3-phase disconnect.
	Low entering air temperature. (Low load conditions).	Check entering air wet bulb conditions.
	Refrigerant leak.	Check system for leaks. Repair leaks and add refrigerant.
	Evaporator dirty or iced-up, or airflow restricted.	Clean the coil. Check fan operation. Check airflow.
	Plugged liquid line filter-drier.	Replace filter-drier, check psi across filter.
	Improper hot gas bypass setting (if equipped).	Check setting and correct as required.
	Expansion valve defective, superheat too high or valve too small.	Adjust valve for proper superheat or replace the expansion valve if too small or defective.
Moisture in system, check sight glass.	Reclaim refrigerant, check for leaks, recharge.	

Always have a completed Pre-Start-Up Checklist and Start-Up Checklist prior to requesting parts or service information.

Troubleshooting – Refrigeration Circuit

Symptom	Possible Cause	Corrective Action
Low discharge pressure	Insufficient refrigerant charge.	Check subcooling, check for leak. Repair leak and add refrigerant.
	Defective or improperly adjusted expansion valve.	Check superheating and adjust thermal expansion valve.
	Low suction pressure.	See “low suction pressure”.
	Faulty condenser temperature controls. (Condensing fan cycle switch).	Check condenser controls and reset to obtain desired condensing temperature.
Compressor short cycles	Thermostat location or controls malfunction.	Check thermostat, check heat anticipator setting.
	Improper refrigerant charge.	Check subcooling, verify superheat.
	Defective high or low pressure control.	Check high or low pressure switch.
	Poor air distribution.	Check ductwork for recirculating.
	Low airflow at evaporator coil.	Check blower operation and airstream restrictions.
	Incorrect unit selection (oversized).	Contact factory.
Compressor loses oil	Refrigerant leak.	Check system for leaks. Repair leaks and add refrigerant.
	Short cycling.	Check low pressure control settings.
	Refrigerant flood back.	Check thermal expansion valve setting. Check for refrigerant overcharge. Check crankcase heater operation.
	Reheat flush cycle inadequate.	Contact factory.
Not enough capacity or lack of performance	Refrigeration undercharged.	Check subcooling. Adjust charge, if necessary.
	Dirty filter or evaporating coil.	Check filter, coil and airflow.
	Dirty or clogged condensing coil.	Check coil and airflow.
	Air or other non-condensables in system.	Check equalized high side pressure with equivalent outdoor temperature.
	Restriction in suction and liquid line.	Check for restrictions in refrigerant circuit.
	Control contacts stuck.	Check wiring.
	Excessive load.	Add more equipment or reduce room load.
Liquid line is frosted or wet	Restriction in liquid line.	Clear restriction upstream of point of frosting. (Note: liquid line frosting is normal on ASHP units).
Suction line is frosting	Insufficient evaporating coil airflow.	Check airflow, check filters, check VFD control signal for proper operation.
	Malfunctioning or defective expansion valve.	Check bulb of thermal expansion valve.
Frost on evaporating coil (Note: Normal on ASHP units in heating mode).	Hot gas bypass valve not functioning properly (if equipped).	Check valve. If defective, replace.
	Manual hot gas bypass valve closed (if equipped).	Open valve.
	Low load or airflow.	Increase airflow, check filters.

Always have a completed Pre-Start-Up Checklist and Start-Up Checklist prior to requesting parts or service information.

Routine Maintenance

DANGER

Electric shock hazard. Can cause injury or death. Before attempting to perform any service or maintenance, turn the electrical power to the unit to OFF at disconnect switch(es). Unit may have multiple power supplies.

CAUTION

Use caution when removing access panels or other unit components, especially while standing on a ladder or other potentially unsteady base. Access panels and unit components can be heavy and serious injury may occur.

This unit requires minimal maintenance to operate properly. Maintenance requirements for this model vary for each installation and depend greatly on how much the system is used and the cleanliness of the air. Proper maintenance will both increase the life of the system and maintain its efficiency. Maintenance must be performed by experienced technicians and in the case of refrigeration systems, must be done by an EPA certified technician.

Maintenance frequency is based on a presumed nominal use of the system. If the system is being run constantly, the frequency should be adjusted accordingly. If there is seasonal debris in the air which can be drawn into the filters and the coils, they should be checked more frequently. If the system is being used for only a few hours per day, the frequency may be reduced. Use the maintenance log at the end of this manual to record each maintenance session and observations and then establish a maintenance schedule that is appropriate for the installation. The following is provided as a guideline.

Maintenance Frequency:

Monthly

1. External Filter
Clean metal mesh filters
2. Internal Filters
Replace MERV 8 filters monthly.
Adjust replacement schedule for MERV 13 and MERV 14 or other filters as inspection requires.

Semiannually

1. Check motor and motor bearings
Check for excessive heat, vibration or noise.
Lubricate bearings in accordance with the motor manufacturer's recommendations.
2. Condensate Drain (if applicable)
Inspect and clean – refill with water
3. Heat Transfer Coils (if applicable)
Inspect for cleanliness – clean as required
4. Outdoor Fan Blades and Motor (if applicable)
Check for cleanliness
Check all fasteners for tightness
Check for fatigue, corrosion, wear

Annually

It is recommended that the annual inspection and maintenance occur at the start of the cooling season. After completing the checklist, follow the unit start-up checklist provided in the manual to ensure the refrigeration system operates in the intended matter.

1. Lubrication
Apply lubricant where required
2. Dampers
Check for unobstructed operation
3. Blower Wheel and Fasteners
Check for cleanliness
Check all fasteners for tightness
Check for fatigue, corrosion, wear
4. Door Seal
Check if intact and pliable
5. Wiring Connections
Check all connections for tightness
6. Cabinet
Check entire cabinet, inside and out, for dirt buildup or corrosion. Remove accumulated dirt, remove any surface corrosion and coat the area with appropriate finish.
7. UV-C Lamps
Check bulbs for cracks or damage and replace them after 1 year of use or roughly 9,000 hours. The effectiveness of the lights decreases after 1 year of use. If bulbs are not replaced before 9,000 hours routine maintenance needs to be more frequent to ensure lights are still functioning properly.

Routine Maintenance

Maintenance Procedures:

Lubrication - Check all moving components for proper lubrication. Apply lubricant where required. Any components showing excessive wear should be replaced to maintain the integrity of the unit and ensure proper operation.

Dampers - Check all dampers to ensure they open and close properly and without binding. Backdraft dampers can be checked by hand to determine if blades open and close freely. Apply power to motorized dampers to ensure the actuator opens and closes the damper as designed.

Gas Furnace - Maintain furnace in accordance with instructions in the Indirect Gas-Fired Heat IOM shipped with this unit.

Fan Motors - Motor maintenance is generally limited to cleaning and lubrication. Cleaning should be limited to exterior surfaces only. Removing dust and grease buildup on the motor housing assists proper cooling. Never wash-down the motor with high pressure spray. Greasing of motors is only intended when fittings are provided. Fan motors typically have two grease fittings. Each motor manufacturer has different lubrication schedules for different models. Go to the motor manufacturer's website and download their maintenance requirements. **Do not over-lubricate motors or use an incompatible grease.** Many fractional motors are permanently lubricated for life and require no further lubrication.

Fan Wheel and Fasteners - Wheels require very little attention when moving clean air. Occasionally oil and dust may accumulate on the wheel causing imbalance. When this occurs, the wheel and housing should be cleaned to assure smooth and safe operation. Inspect fan impeller and housing for fatigue, corrosion, or wear.

Routinely check all fasteners, set screws and locking collars on the fan, bearings, drive, motor base and accessories for tightness. A proper maintenance program will help preserve the performance and reliability designed into the fan.

Coil Maintenance - Coils must be cleaned to maintain maximum performance. Check coils once per year under normal operating conditions and if dirty, brush or vacuum clean. Soiled fins reduce the capacity of the coil, demand more energy from the fan and create an environment for odor and bacteria to grow and spread through the conditioned zone. High pressure water (700 psi or less) may be used to clean coils with a fin thickness over 0.0095 inches thick. **TEST THE SPRAY PRESSURE** over a small corner of the coil to determine if the fins will withstand the spray pressure. For coils with fragile fins or high fin density, foaming chemical sprays and washes are available. Many coil cleaners use harsh chemicals, so they must be used

with caution by qualified personnel only. Care must be taken not to damage the coils, including the fins, while cleaning. **Caution: Fin edges are sharp!**

WARNING

REFER TO GENERAL SAFETY INFORMATION

Do not operate this unit without the filters and birdscreen installed. They prevent the entry of foreign objects such as leaves, birds, etc.

Do not remove access panels or other unit components while standing on a ladder or other unsteady base. Access panels and unit components are heavy and serious injury may occur.

Internal Filter Maintenance - The unit will typically be provided with 2-inch thick pleated paper filters in the airstream. These filters should be checked according to a routine maintenance schedule and replaced as necessary to ensure proper airflow through the unit. Replacement filters shall be of same performance and quality as factory installed filters. Filter must be pleated design with integral metal grid. Two acceptable filter replacements are Aerostat Series 400 or Farr 30/30®.

Filters upstream of the coil should be checked regularly. If the filters are dirty, they should be cleaned or replaced. It is important the filters stay clean to maintain desired airflow.

External Filter Maintenance - Aluminum mesh, 2-inch thick filters are located in the supply weatherhood (if the weatherhood option was purchased). These filters should be checked and cleaned on a regular basis for best efficiency. The frequency of cleaning depends upon the cleanliness of the incoming air. These filters should be cleaned by rinsing with a mild detergent in warm water prior to start-up.

Aluminum filters are removable from either the front or side of the weatherhood.

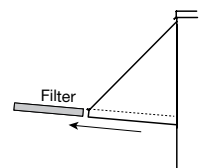

Outdoor Air Intake Hood
Mesh Filter Access

WARNING

Biological hazard. May cause disease. Cleaning should be performed by qualified personnel.

Drain pans in any air conditioning unit will have some moisture in them, therefore, algae and other organisms will grow due to airborne spores and bacteria. Periodic cleaning is necessary to prevent this buildup from plugging the drain and causing the drain pan to overflow. Inspect twice a year to avoid the possibility of overflow. Also, drain pans should be kept clean to prevent the spread of disease. Cleaning should be performed by qualified personnel.

Routine Maintenance

Model	Outdoor Air Weatherhood (Aluminum Mesh)	Outdoor Filters	Exhaust Filters	Supply Final Filters (Pre-coil)
RV-10	(1) 16x20x1	NA	NA	(1) 12x24 + (1) 24x24
RV-25 (5, 7, 10 tons)	(4) 20x20x2	NA	NA	(4) 20x20
RV-25 (12.5, 15 tons)	(4) 20x20x2	NA	NA	(2) 20x20 + (2) 20x24
RV-45	(4) 25x25x2	NA	NA	(3) 16x20 + (3) 20x20
RV-75	(12) 16x20x2	NA	NA	(8) 20x20 + (4) 16x20
RV-110	(8) 20x25x1	NA	NA	(6) 20x24 + (6) 20x20
RVE-40 (5, 7, 10 tons)	(4) 20x20x2	(2*) 20x25x2	(2*) 20x25x2	(4) 20x20
RVE-40 (12.5, 15 tons)	(4) 20x20x2	(2*) 20x25x2	(2*) 20x25x2	(2) 20x20 + (2) 20x24
RVE-85	(4) 25x25x2	(4**) 16x25x2	(4**) 16x25x2	(3) 16x20 + (3) 20x20
RVE-150	(12) 16x20x2	(8) 20x24	(8) 20x24	(8) 20x20 + (4) 16x20
RVE-180	(8) 20x25x1	(9) 20x24x2 + (3) 20x20x2	(6) 20x24x2 + (2) 20x20x2	(6) 20x24 + (6) 20x20
RVC-35	(4) 20x20x2	(3) 16x25x2	(3) 16x25x2	(2) 20x20 + (2) 20x24
RVC-65	(6) 16x20x2	(4) 16x25x2	(4) 16x25x2	(3) 16x20 + (3) 20x20
RVC-145	(8) 20x25x1	(9) 20x24x2 + (3) 20x20x2	(6) 20x24x2 + (2) 20x20x2	(6) 20x24 + (6) 20x20

* Based upon a 30 / 36 in. energy wheel (16x25x2, quantity of 3 for 41 in. energy wheel)

** Based upon a 52 in. energy wheel (16x16x2, quantity of 8 for 58 in. energy wheel)

Reference - Venting Connection Locations (Models RV-25, -45, RVE-40, -85)

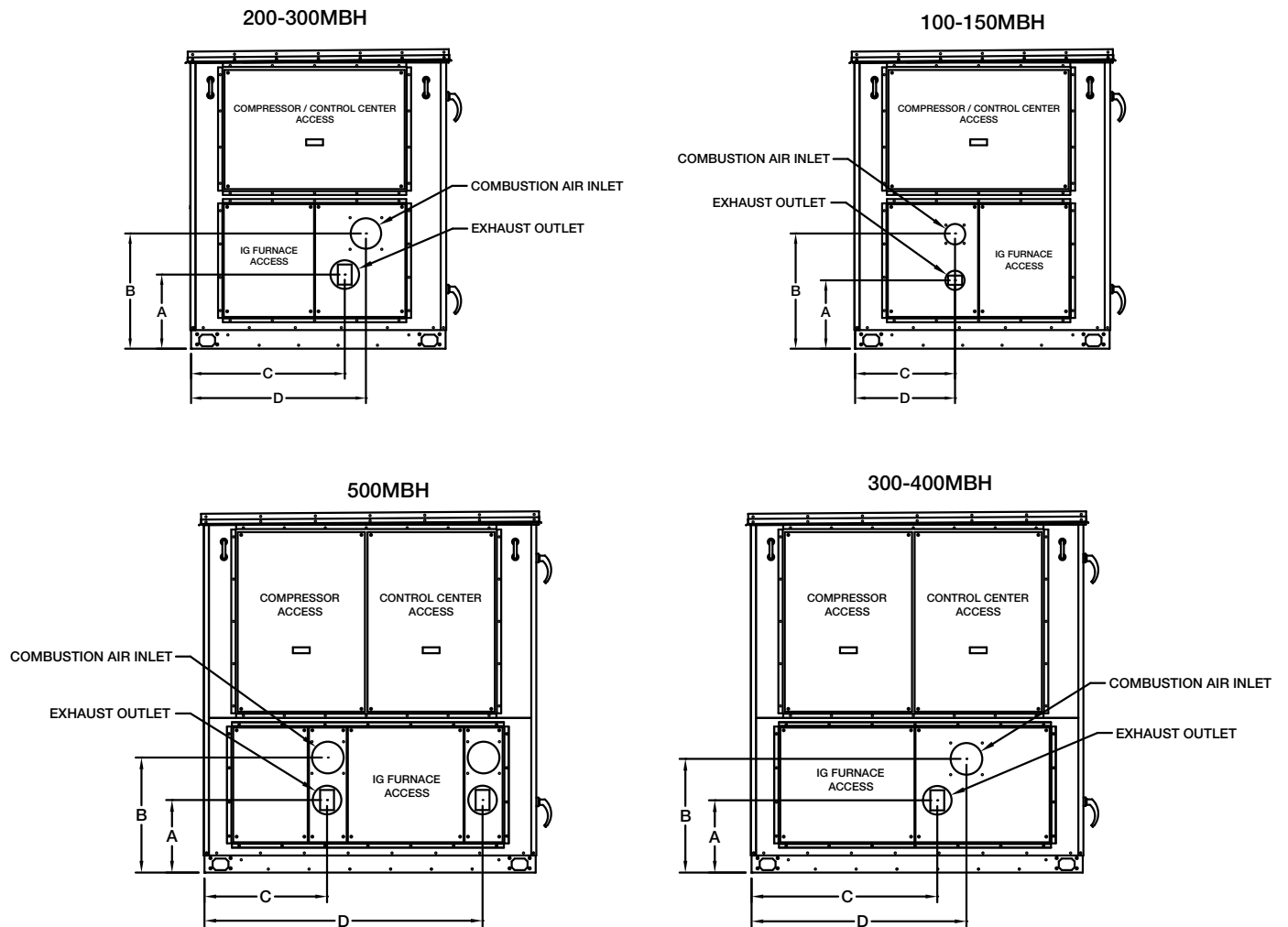

IG Venting Location								
Housing Size	Furnace Size (MBH)	A	B	C	D	Flue Connection Size (diameter in inches)		
						Standard Exhaust	2-Pipe/Concentric Exhaust	Intake
						25/40	100	14
	200	15.2	23.7	31.5	35.9	6	6	6
	300					6	6	6
45/85	300	14.8	23.3	38.1	44.1	6	6	6
	400					6	6	6
		500	14.9	23.6	25.2	57.1	6	6

Reference - Venting Connection Locations Cont.

(Models RV-110, RVC-145, RVE-180) *NO indoor venting options available*

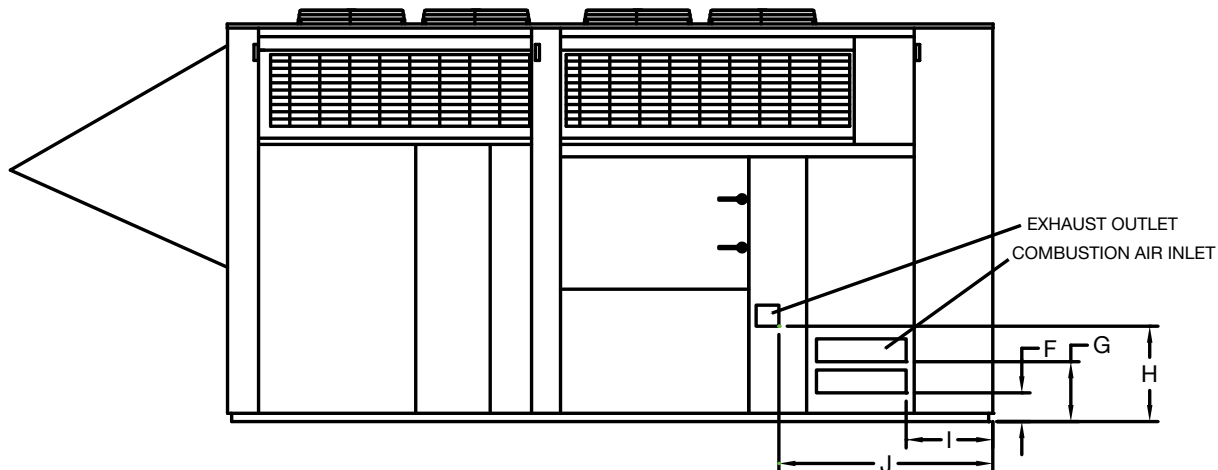
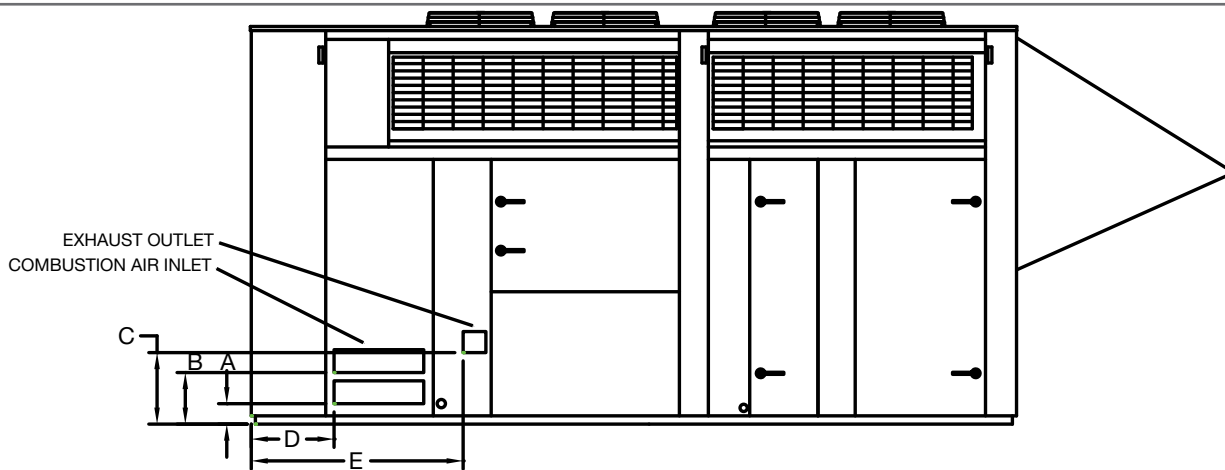

IG Venting Location																
Housing Size	Furnace Size (MBH)	A	B	C	D	E	F	G	H	I	J	Inlet Dimensions		Outlet Dimensions		
												Length	Height	Edge Thickness	Length	Height
110/145/180	600	6	13.8	17.2	20.5	50	NA	NA	NA	NA	NA	21.5	6	1	6.5	5.5
	800	6	13.8	24.7	20.5	49.8	6	13.7	18.5	20.5	49.7	20.5	6	1	6.5	5.5
	1000	6	13.8	17.2	20.5	50	6	13.7	24.2	20.5	49.9	21.5	6	1	6.5	5.5
	1200	6	13.8	17.2	20.5	50	6	13.7	24.2	20.5	49.9	21.5	6	1	6.5	5.5

Reference - Rated Airflow

Model	Airflow (SCFM)
RV-10-3I	1100
RV-10-4I	1450
RV-10-5I	1700
RV-10-6I	1900
RV-10-7I	1900
RV-25-5I	3000
RV-25-5A	3400
RV-25-7(I,J)	2300
RV-25-7.5(I,J)	2300
RV-25-7.5A	3000
RV-25-10(I,J)	2700
RV-25-10A	4400
RV-25-12.5(I,J)	2900
RV-25-12.5A	4400
RV-25-15(I,J)	3300
RV-25-15A	4300
RV-45-15(I,J)	4100
RV-45-15A	4800
RV-45-17.5(I,J)	4650
RV-45-17.5D	4650
RV-45-17.5A	5500
RV-45-20(I,J)	4900
RV-45-20D	5100
RV-45-20A	6400

Model	Airflow (SCFM)
RV-45-25(I,J)	5750
RV-45-25D	5600
RV-45-25A	7200
RV-45-30(I,J)	6000
RV-45-30D	6000
RV-45-30A	7000
RV-75-25(I,J)	8300
RV-75-25D	8300
RV-75-30(I,J)	9400
RV-75-30D	9500
RV-75-40(I,J)	10000
RV-75-40D	10000
RV-75-50(I,J)	10800
RV-75-50D	10800
RV-110-30(I,J)	9000
RV-110-30D	9000
RV-110-40(I,J)	10500
RV-110-40D	10500
RV-110-50(I,J)	11000
RV-110-50D	10500
RV-110-60(I,J)	14000
RV-110-60D	14000
RV-110-70(I,J)	16000
RV-110-70D	16000

Full load rating airflow per AHRI 340/360

D = digital compressor

I, J = Inverter compressor

A = ASHP

Our Commitment

As a result of our commitment to continuous improvement, Greenheck reserves the right to change specifications without notice.

Product warranties can be found online at Greenheck.com, either on the specific product page or in the literature section of the website at Greenheck.com/Resources/Library/Literature.

Greenheck's Model RV, RVE and RVC catalog provides additional information describing the equipment, fan performance, available accessories, and specification data.

AMCA Publication 410-96, Safety Practices for Users and Installers of Industrial and Commercial Fans, provides additional safety information. This publication can be obtained from AMCA International, Inc. at www.amca.org.



Submittal Review Comment Transmittal



Date: 12/14/2022

Project Name: Jones Hall Renovation

Project No.: 21054

Owner: Arkansas Tech University

Contractor: Alessi Keyes Construction
Attn: Charley Dawson
10623 Maumelle Boulevard
North Little Rock, AR. 72113

Contract Date: 9-12-22

Delivered by: E-mail

Submittal: 23 74 13 Packaged HVAC Units Product Data

Accepted

Accepted as Noted

Revise and Resubmit

Not Accepted

By: Ericka Smith, AIA Assoc.

Acceptance is subject to the provisions of the General Conditions of the Contract for Construction AIA Document A201.

Submittal Comments:

- Refer to all notes/comments on attached submittal from Pettit & Pettit Engineers
- **NOTE: Packaged HVAC unit provided in submittal is heavier than specified unit. Submittal is Approved as Noted, however, structural is currently reviewing the load capacity with regards to the existing roof structure. Changes may need to be issued via ASI or Proposal Request to accommodate the additional load of the unit.**

Attachments: (List attached documents that support the description)

By: **Ericka Smith, AIA Assoc.**

CC: Central File: J:\2021\21054 Jones Hall ATU\1800 Submittals\1823 - HVAC\23 74 13 Packaged HVAC Units Product Data\Consultant\22-1213 AAN 23 74 13 Packaged HVAC Units Product Data.docx

REVIEW OF MECHANICAL SUBMITTALS

Project: Arkansas Tech University – Jones Hall
Location: Russellville, Arkansas
Date of Receipt: Monday, October 31, 2022
Date of Review: Thursday, December 1, 2022
Reviewed by: Terry Jacks
Email: tjacks@pettitinc.com

P&P Job No. 21-108

Signed: 

Checking is for conformance with the design concept of the Project and compliance with the information given in the Contract Documents. The Contractor is responsible for dimensions to be confirmed and correlated at the job site; for information that pertains solely to the fabrication processes or to techniques of construction; and for coordination of the work of all trades.

Item	Approval Status		Comments
Section 23 74 13 – Packaged HVAC Units	Approved as Corrected	○	<ul style="list-style-type: none"> - MCA and MOP exceed specified unit. Coordinate all required electrical changes with electrical contractor. - Provide galvanized service platform structure equal to equipment curb, walking surface, and handrails. - Provide layer of roofing material between service platform feet and existing roof. - Provide extra sets of belts and filters as specified. - Provide 5 year extended compressor warranty. - Provide hail guards.



Note:



SUBMITTAL DATA

EQUIPMENT: Greenheck Packaged Rooftop VAU

TAGS: VAU-1

PROJECT: ATU Jones Hall Renovation

LOCATION: Russellville, AR

ENGINEER:



CONTRACTOR:



DATE: 9/8/2022

SUBMITTED BY: Forrest Moseley
forrest@airetechcorp.com
(501) 425-6112

RVE-85-52D-25I-J-A0

Unit Performance

Design Conditions						
Elevation (ft)	Summer		Winter DB (F)	Supply (CFM)	Outdoor Air (CFM)	Exhaust Air (CFM)
	DB (F)	WB (F)				
338	91.0	79.0	16.0	5,200	5,200	2,600

Unit Specifications						
Qty	Weight (lb)	Cooling Type	Heating Type	Unit Installation	Unit ETL Listing	Furnace ETL Listing
1	4,997 (+/- 5%)	Packaged DX	Indirect Gas	Outdoor	ULcUL 1995	ANSI Z83.8 / CSA 2.6

Configuration				
Outdoor Air			Exhaust Air	
Intake	Discharge		Intake	Discharge
End	Bottom		Bottom	Side

ASHRAE 90.1-2019 Compliance			
	ASHRAE 90.1 Min. Efficiency	Calculated Efficiency	Compliance
ISMRE	5.2	6.5	✓
Enthalpy Recovery Ratio (%)	50	44.5	✗

Energy Recovery Performance									
Design Condition	Temperature (F)								Capacity Reduction (BTU/h)
	Outdoor Air		Supply Air		Return Air		Exhaust Air		
	DB	WB	DB	WB	DB	WB/RH	DB	WB	
Summer	91.0	79.0	83.9	72.5	75.0	62.5/50	88.5	76.7	152,100.0
Winter	16.0	13.0	39.0	33.7	72.0	55.8/35	24.6	21.6	129,168.0

Cooling Specifications							
Type	Total Capacity (MBH)	Sensible Capacity (MBH)	Lead Compressor Type	Coil (DB/WB)		Reheat	
				EAT (F)	LAT (F)	Capacity (MBH)	LAT (F)
Packaged DX	335.8	176.6	Inverter Scroll	83.9 / 72.5	53.1 / 52.9	139.1	77.9

Heating Specifications								
Type	Gas Type	Input (MBH)	Output (MBH)	Temperature Rise		Turndown	Performance	
				Min (F)	Max (F)		EAT (F)	LAT (F)
Indirect Gas	Natural	300.0	240.0	4.0	43.0	12:1	39.0	81.8

Air Performance							
Type	Total Volume (CFM)	External SP (in. wg)	Total SP (in. wg)	FRPM	Fan		
					Qty	Type	Drive-Type
Supply	5,200	1.5	4.093	1699	1	Plenum	Direct
Exhaust	2,600	1.5	2.068	1149	1	Plenum	Direct

Motor Specifications						
Motor	Qty	Operating Power (hp)	Size (hp)	Enclosure	Efficiency	RPM
Supply	1	5.13	7-1/2	ODP	PE	1770
Exhaust	1	1.41	3	ODP	PE	1760

Electrical Specifications				
Power Supply	Rating (V/C/P)	MCA (A)	MOP (A)	Fan Power (W/CFM)*
Unit	208/60/3	154.5	200.0	0.938

*Fan Power (W/CFM) = (Supply BHP + Exhaust BHP) / Supply CFM

Construction Features And Accessories

Unit	
Unit Installation - Outdoor	Std
Unit Construction - Double Wall	Std
Insulation - 2 inch 2.4# R13 foam	Std
Corrosion Resistant Fasteners	Std
Hinged Access	Std
Factory Wired Non-Fused Disconnect Switch	X
Direct Drive Plenum Blower & Motor Assemblies	Std
Factory Wired VFDs	Std
Unit Finish - Permatector, Concrete Gray (RAL 7023)	X
Stainless Steel Condensate Drain Pan and Connection	Std
Condensate Drain Trap	Std
Short Circuit Current - 5 kA	Std
Energy Recovery Device - Polymer Wheel w/ Silica Gel Desiccant	Std
Controls	
Unit Controls - Full Control	Std
Internally Mounted Control Center with 24 VAC control transformer(s) and control circuiting fusing	Std
BMS Protocol - BACNetMSTP	X
BMS Monitoring Points	
Supply Fan Control - Constant Volume-Adj. Setpoint	X
Exhaust Fan Control - Constant Volume-Adj. Setpoint	X
Economizer Control	
Exhaust Fan Only Power	
Web-Based User Interface	
Energy Wheel Economizer Control	
Energy Wheel Rotation Sensor	
Outd/Rec. Air Damper Ctrl - 100% OA-No Recirculation	X
Control Accessories	
Remote Display	
Dirty Filter Sensor(s)	
Airflow Monitor - Exhaust Air, Supply Air	X
Room Thermostat	
Phase/Brownout Protection	Std
Economizer Fault Detection Diagnostics	

Accessories	
Frost Control - None	
Outdoor Air Damper - Low Leakage	X
Return Air Damper	
Roof Curb - GKD - 63.74/158.9-G14	X
Supply Air Filters - 2" Merv 8 And 2" Merv 13, 16-16x25x2	X
Service Outlet	
Piping Vestibule	
Vapor Tight Lights	
Condensate Overflow Switch	X
Spare Filters	
Exhaust Discharge Gravity Backdraft Damper	Std
ElectroFin Coil Coating	
Motor Shaft Grounding	
Energy Wheel Bypass Damper	
Return Air Filters - 2" Merv 8, 4-16x25x2	Std
Outdoor Air Filters - 2" Merv 8, 4-16x25x2	Std
Furnace Control - 12:1 Modulating	X
Spare Energy Wheel Belt	
Spare Energy Wheel Segments	
UV Lights	
Bipolar Ionization	
Smoke Detector(s)	
Barometric Relief Damper	
Energy Core Bypass Damper	
Power Venting	Std
Hail Guards	X
Warranty Options	
Unit Warranty - 18 Months (Std.)	Std
Energy Wheel Warranty - 5 Yrs Less Motor	Std
Compressor Warranty - 5.5 Yrs. (4 Yrs. Extended)	X
Furnace HX Warranty - 25 Yrs.	Std

Standard Option	Std
Not Included	
Included	X

Notes
Outdoor Air Damper supplied is low leakage, motorized VCD-23 (leakage rate of 3 CFM / ft ² @ 1 in. wg), Class 1A

Supply Fan Charts And Performance

Supply Fan Performance									
Total Volume (CFM)	External SP (in. wg)	Total SP (in. wg)	RPM	Operating Power (hp)	Motor		Fan		
					Qty	Size (hp)	Qty	Type	Drive-Type
5,200	1.5	4.093	1699	5.13	1	7-1/2	1	Plenum	Direct

Pressure Drop (in. wg)						
Weatherhood	Filter	Damper	Cooling	Heating	External	Total
0.15	0.246	0.05	0.291	0.506	1.5	4.093

Sound Performance in Accordance with AMCA										
Sound Power by Octave Band								Lwa	dBA	Sones
62.5	125	250	500	1000	2000	4000	8000			
88	89	95	82	79	73	72	70	88	77	28

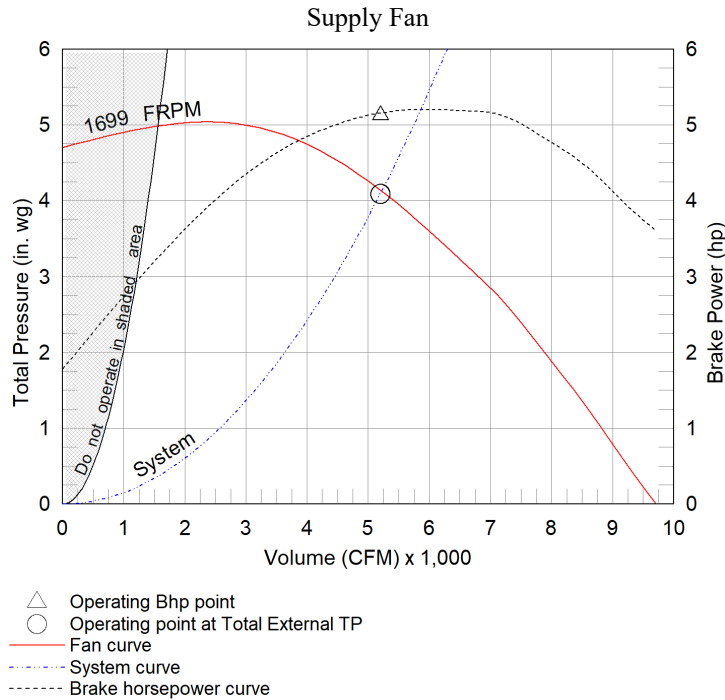

Exhaust Fan Charts And Performance

Exhaust Fan Performance									
Total Volume (CFM)	External SP (in. wg)	Total SP (in. wg)	RPM	Operating Power (hp)	Motor		Fan		
					Qty	Size (hp)	Qty	Type	Drive-Type
2,600	1.5	2.068	1149	1.41	1	3	1	Plenum	Direct

Pressure Drop (in. wg)						
Weatherhood	Filter	Damper	Cooling	Heating	External	Total
0.02	-	-	-	-	1.5	2.068

Sound Performance in Accordance with AMCA										
Sound Power by Octave Band								Lwa	dBA	Sones
62.5	125	250	500	1000	2000	4000	8000			
91	79	74	67	61	60	58	64	72	61	14

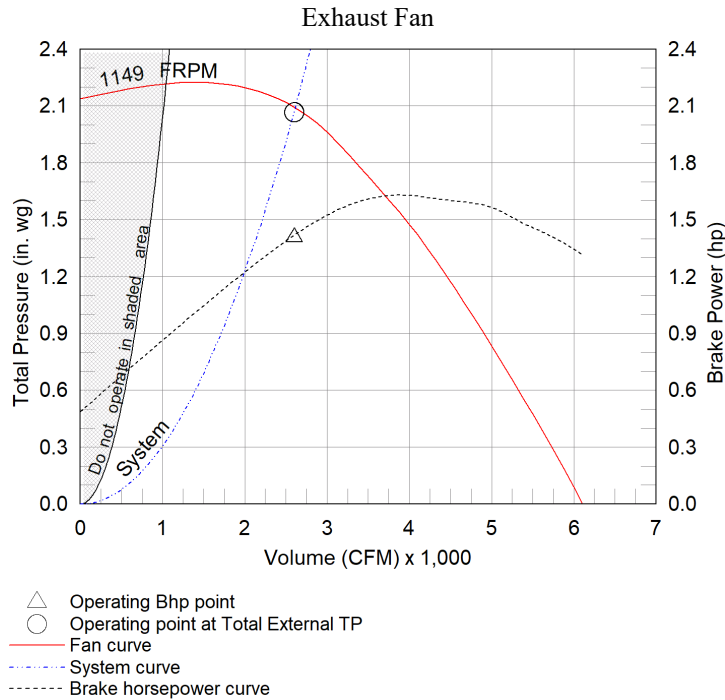

Radiated Sound

Position A

Dimensional Overview

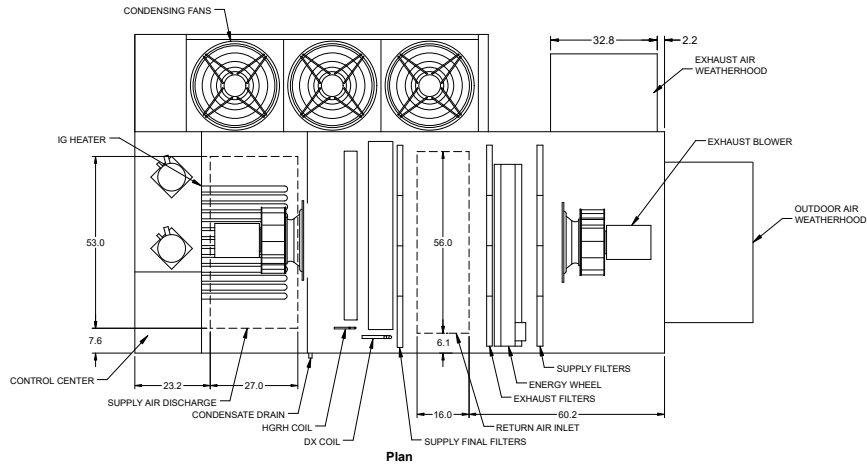

Position D

Position B

Position C

"E" is the Top Plane

Supply Air Flow Nominal, Largest Tonnage Condensing Section Available, PDX units only

Radiated Sound Levels										
Plane	Octave Bands (Lw)								Plane Lw	Plane LwA
	1	2	3	4	5	6	7	8		
A	80	87	82	80	77	72	68	62	90	82
B	74	80	73	67	64	59	55	48	82	71
C	82	77	73	69	67	61	54	46	84	72
D	71	80	74	72	69	63	58	52	82	74
E	77	86	82	78	76	71	66	61	89	81
Total	86	91	86	83	80	75	71	65	94	85

AMCA 320-07 - Laboratory Methods of Sound Testing of Fans Using Sound Intensity
Tests conducted in accordance with this standard.
Free field measurement plane created 1 foot from unit on all sides and top.
Sound Intensity measured in Watts/m ² .
Sound data converted to Sound Power (Lw) for the chart above.
A-Weighted Sound Power was determined using AMCA Standard 301-90 Clause 9.1.
Plane E sound data was measured above the top plane of the unit.

Cooling Performance

Cooling Specifications									
Nominal Tonnage	Entering Air (F)		Leaving Air (F)		Capacity (MBH)		Reheat		Condensing Ambient Temp (F)
	DB	WB	DB	WB	Total	Sensible	Capacity (MBH)	LAT (F)	
25.0	83.9	72.5	53.1	52.9	335.8	176.6	139.1	77.9	91.0

Coil Information									
PDX Coil Model	Fins Per Inch	Rows Deep	Face Vel. (ft/min)	Coil PD (in. wg)	Refrigerant	Refrig. Velocity (ft/min)	Face Area (ft2)	Suction Temp (F)	
DX38S06H12-52x56-LH	12	6	257	0.291	R-410A	1,699	20.2	48.9	

Compressor Details					
Lead Compressor Type	Compressor Qty	Compressor RLA/MRC (A)		Compressor LRA (A)	
		Comp. #1	Comp. #2	Comp. #1	Comp. #2
Inverter Scroll	2	51.3	48.1	NA	245

Unit Details
Refrigerant charges provided by the factory are approximate and may require adjustment in the field
Hermetic scroll type compressors
Compressors mounted on neoprene vibration isolation
Crankcase heater on staged compressor
Electronic expansion valve on lead circuit, thermostatic expansion valve on staged circuit
Stainless steel double sloped drain pan
Moisture-indicating sight glass
Service/charging valves
Refrigerant high pressure switch (manual reset)
Liquid-Line filter drier
Multiple low sound condensing fans with Lead ECM condensing fan for modulating head pressure control
Inverter scroll compressor
Refrigerant low pressure switch (auto reset)

Heating Performance

Heating Specifications								
Type	Gas Type	Input (MBH)	Output (MBH)	Temperature Rise		Turndown	Performance	
				Min (F)	Max (F)		EAT (F)	LAT (F)
Indirect Gas	Natural	300.0	240.0	4.0	43.0	12:1	39.0	81.8

Unit Details
ANSI standard Z83.8 and CSA 2.6
High Thermal efficiency
Direct spark ignition
3/4" Gas Connection
At least 6 in. wg of natural gas pressure (14 in. wg for LP) is required at the units gas connection in order to achieve maximum performance
Power Venting
24 Volt Control Power
Stainless Steel heat exchange tubes
Unit controller maximum allowable supply discharge air set point is 100F (37.8C)
Discharge temperature assumes proper energy wheel operation and maintenance.

Energy Recovery Summer Performance

Outdoor Air		Supply Air	
Dry Bulb (F)	91.0	Dry Bulb (F)	83.9
Wet Bulb (F)	79.0	Wet Bulb (F)	72.5
Specific Humidity (gr/lb)	133	Specific Humidity (gr/lb)	103
Enthalpy (BTU/lb)	42.8	Enthalpy (BTU/lb)	36.3
Exhaust Air		Return Air	
Dry Bulb (F)	88.5	Dry Bulb (F)	75.0
Wet Bulb (F)	76.7	Rel. Humidity (%)	50
Specific Humidity (gr/lb)	121	Specific Humidity (gr/lb)	66
Enthalpy (BTU/lb)	40.3	Enthalpy (BTU/lb)	28.3

Design Air Flow Conditions			
OA Volume (CFM)	ASHRAE 90.1 OA Enthalpy Recovery Ratio	EA Volume (CFM)	EA Wheel Effectiveness
5,200	44.5	2,600	80.8

Outdoor Air Cooling Reduction				
OA Load w/o Energy Recovery		OA Load with Energy Recovery		Equipment Reduction (tons)
(BTU/h)	(tons)	(BTU/h)	(tons)	
339,300.0	28.28	187,200.0	15.60	12.68

Summer Conditions

- 1 = Outdoor Air Design
- 2 = Energy Wheel
- 3 = DX Coil
- 4 = Hot Gas Reheat
- 5 = Exhaust Air Entering Wheel

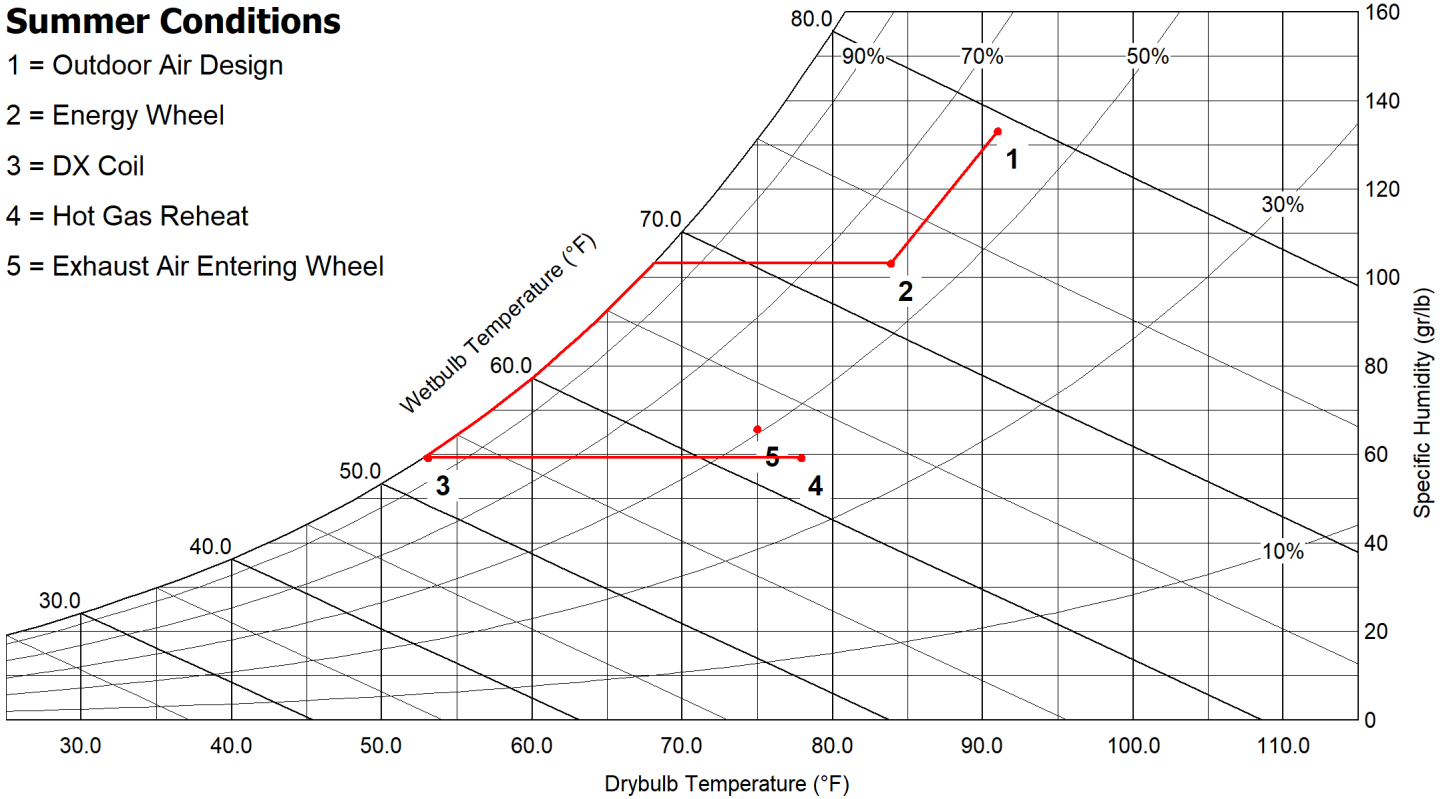

Energy Recovery Winter Performance w/out Preheater

Outdoor Air		Supply Air	
Dry Bulb (F)	16.0	Dry Bulb (F)	39.0
Wet Bulb (F)	13.0	Wet Bulb (F)	33.7
Specific Humidity (gr/lb)	6	Specific Humidity (gr/lb)	20
Enthalpy (BTU/lb)	4.8	Enthalpy (BTU/lb)	12.5
Exhaust Air		Return Air	
Dry Bulb (F)	24.6	Dry Bulb (F)	72.0
Wet Bulb (F)	21.6	Rel. Humidity (%)	35
Specific Humidity (gr/lb)	12	Specific Humidity (gr/lb)	41
Enthalpy (BTU/lb)	7.7	Enthalpy (BTU/lb)	23.7

Design Air Flow Conditions			
OA Volume (CFM)	ASHRAE 90.1 OA Enthalpy Recovery Ratio	EA Volume (CFM)	EA Wheel Effectiveness
5,200	40.7	2,600	80.9

Outdoor Air Heating Reduction			
OA Load w/o Energy Recovery (BTU/h)	OA Load with Energy Recovery (BTU/h)	Equipment Reduction (BTU/h)	Sensible Effectiveness (%)
314,496.0	185,328.0	129,168.0	85.2

Winter Conditions

- 1 = Outdoor Air Design
- 2 = Energy Wheel
- 3 = Indirect Gas Heater
- 4 = Exhaust Air Entering Wheel

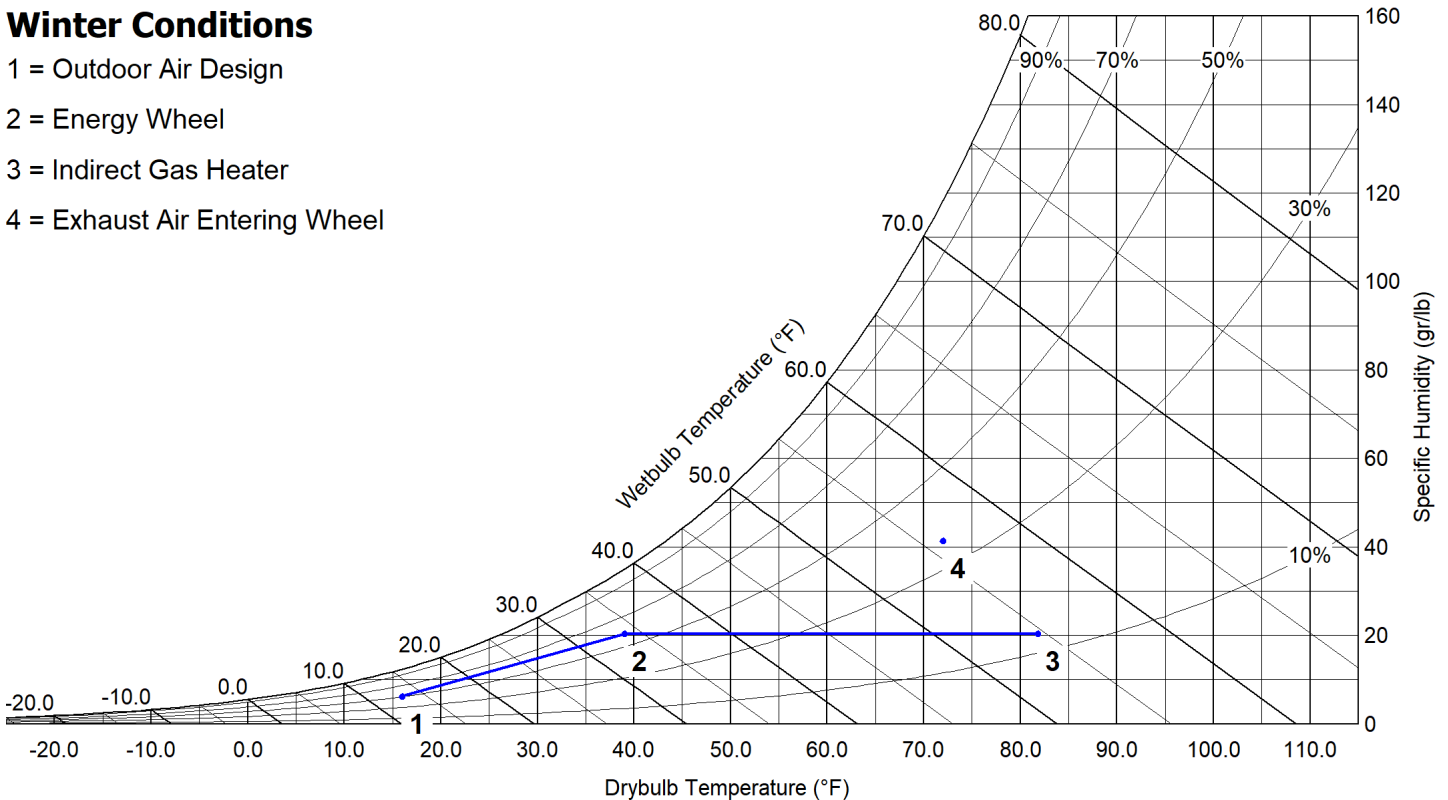

AHRI Performance Ratings

Energy Recovery Performance Rating in accordance with AHRI Standard 1060 (I-P)

Rated Airflow (SCFM)		Net Supply Airflow (SCFM)	EATR (%)	OACF	Pressure Drop (in. wg)		Purge Angle (degrees)
Leaving Supply	Entering Exhaust				Supply	Exhaust	
5355	2755	5200	2.9	1.02	0.75	0.39	0

Thermal Effectiveness Ratings

Enthalpy Recovery		Sensible Effectiveness		Latent Effectiveness		Total Effectiveness	
Summer	Winter	Summer	Winter	Summer	Winter	Summer	Winter
44.5	40.7	84.8	85.2	83.4	84	80.8	80.9

Note(s)

Summer Design Conditions:

Certified in accordance with the AHRI ERV Certification Program, which is based on AHRI Standard 1060. Certified units may be found in the AHRI Directory at www.ahridirectory.org.



Winter Design Conditions:

Application Rating is outside the scope of AHRI ERV Certification Program, but is rated in accordance with AHRI Standard 1060.

Isometric Drawings

Component Layout

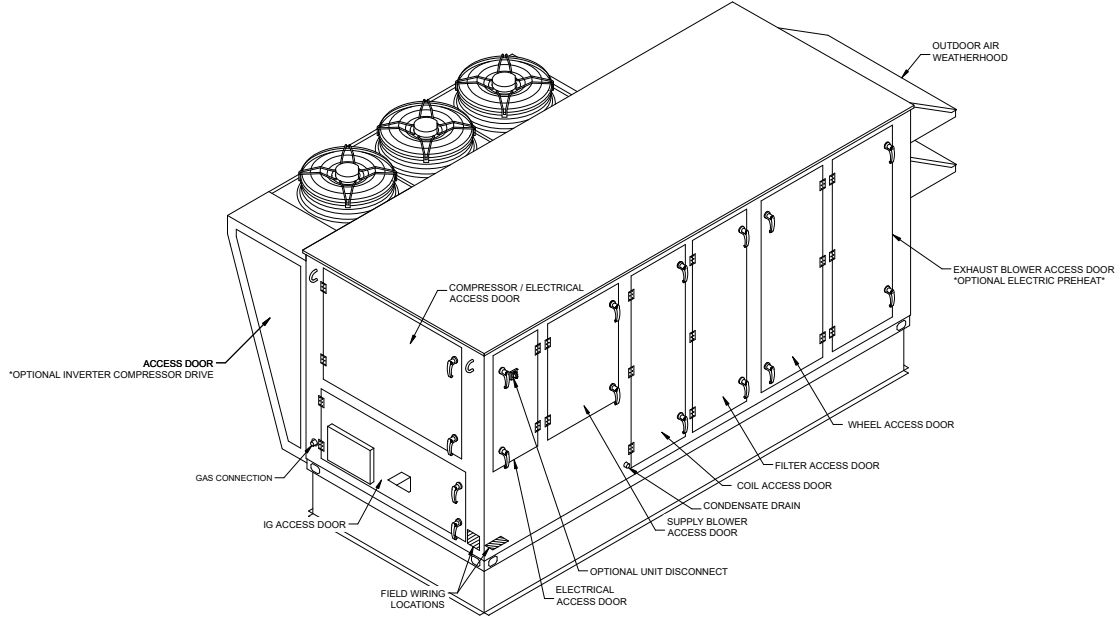

Back Right Isometric

Service Clearances

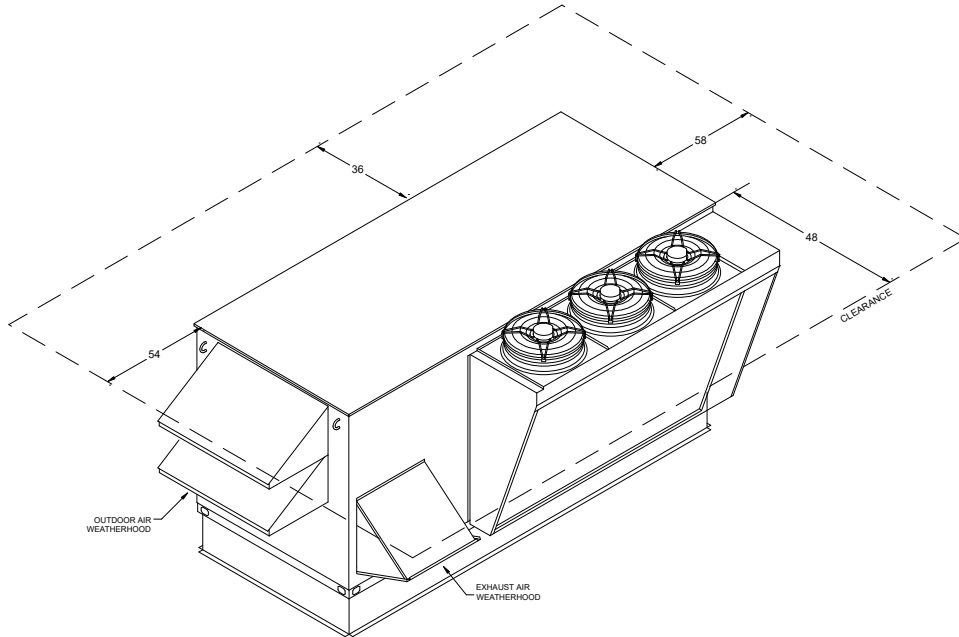

Front Left Isometric

Overview Drawings

Dimensional Overview

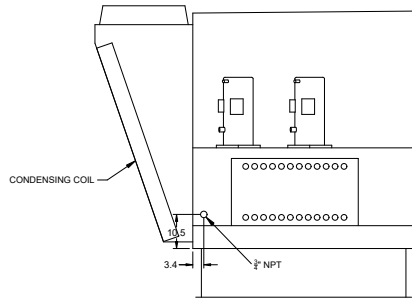
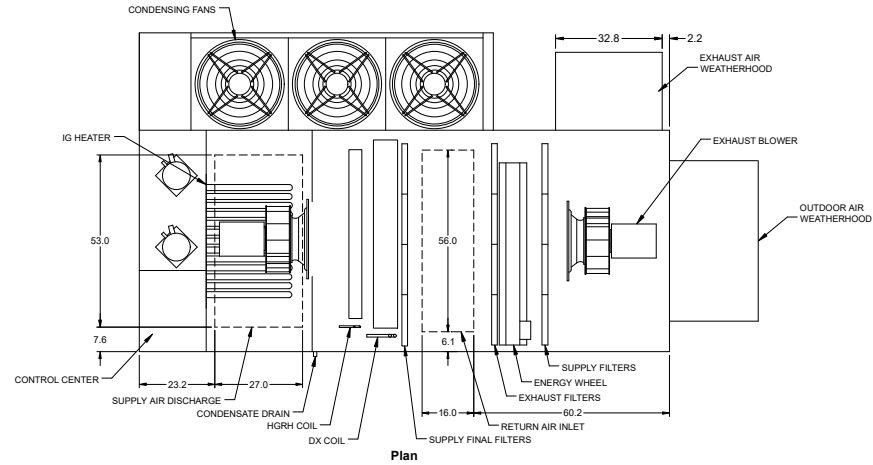

Left End

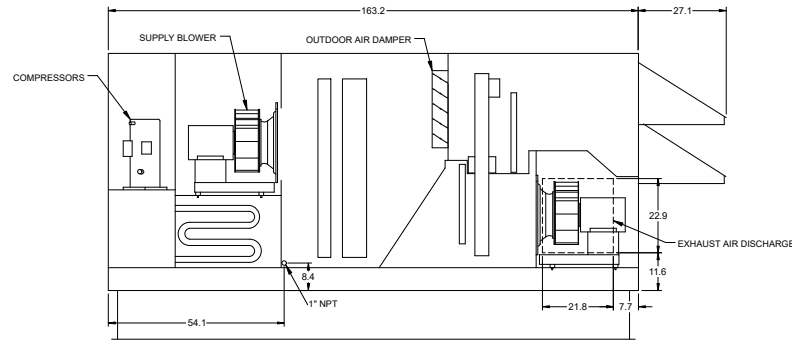

Elevation

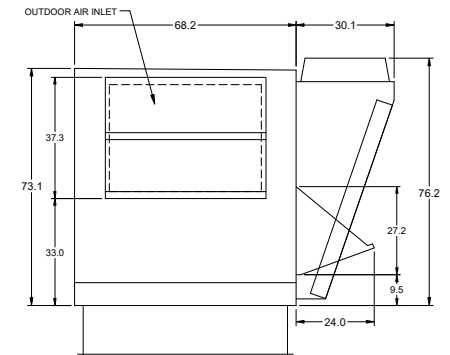

Right End

Unit Corner Weights

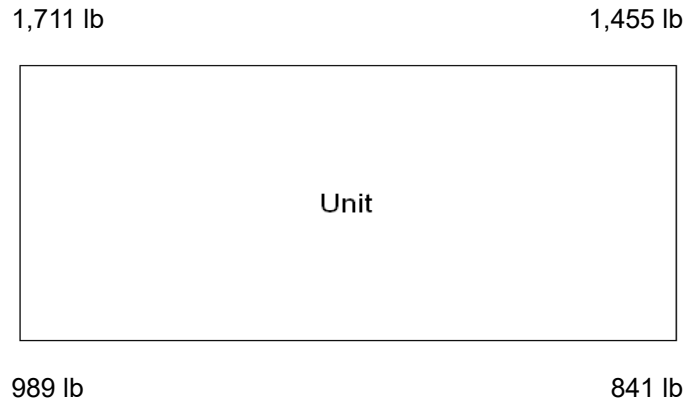

Note

Estimated corner weights are shown looking down on unit and the outside air intake will be on the right. Weights are applied at the base of the unit. Images not drawn to scale.

Wiring Diagram

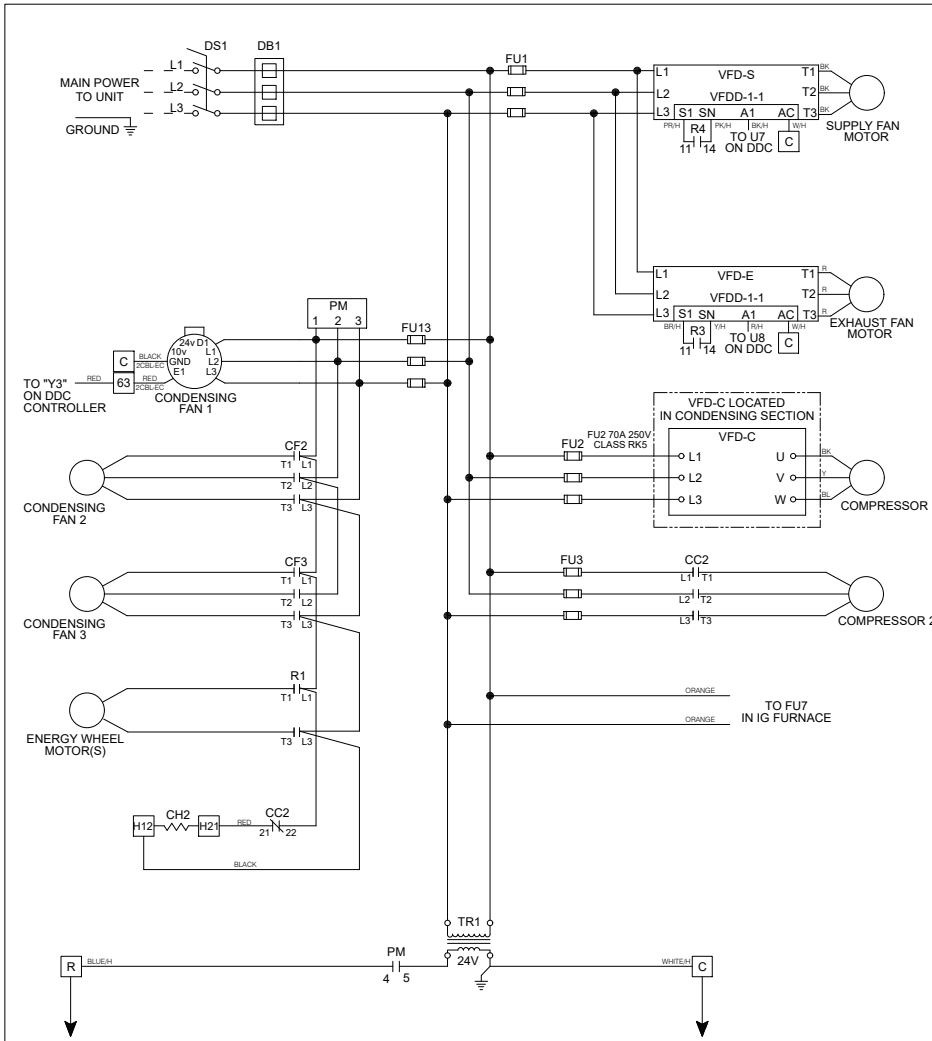

Wiring Diagram Code:
G23E2A1AA00X14X06HM23H0030BH27

CAUTION
 UNIT SHALL BE GROUNDED IN ACCORDANCE WITH N.E.C.
 POWER MUST BE OFF WHILE SERVICING.

NOTES
 USE COPPER CONDUCTORS ONLY
 60° C FOR TERMINALS RATED LESS THAN 100 AMPS.
 75° C FOR TERMINALS RATED 100 AMPS OR MORE.
 FIELD CONTROL WIRING RESISTANCE SHOULD NOT EXCEED 0.75 OHM.
 FIELD WIRED - - - - -
 FACTORY SUPPLIED AND WIRED _____

WIRE COLOR CODE

BK	BLACK	BL	BLUE	BR	BROWN
GY	GRAY	LT BL	LIGHT BLUE	O	ORANGE
PK	PINK	PR	PURPLE	R	RED
W	WHITE	Y	YELLOW		

LEGEND

- CC# COMPRESSOR CONTACTOR
- CF# CONDENSING FAN CONTACTOR
- CH# COMPRESSOR SUMP HEATER
- DB# POWER DISTRIBUTION BLOCK
- DS DISCONNECT SWITCH
- FU# FUSES
- PM PHASE VOLTAGE MONITOR
- R1 ENERGY WHEEL CONTACTOR
- R3 EXHAUST BLOWER VFD RELAY
- R4 SUPPLY BLOWER VFD RELAY
- TR# TRANSFORMER
- VFD VARIABLE FREQUENCY DRIVE

Wiring Template: H27 DOC NUMBER: 2823180 REV: 14

Wiring Diagram 2

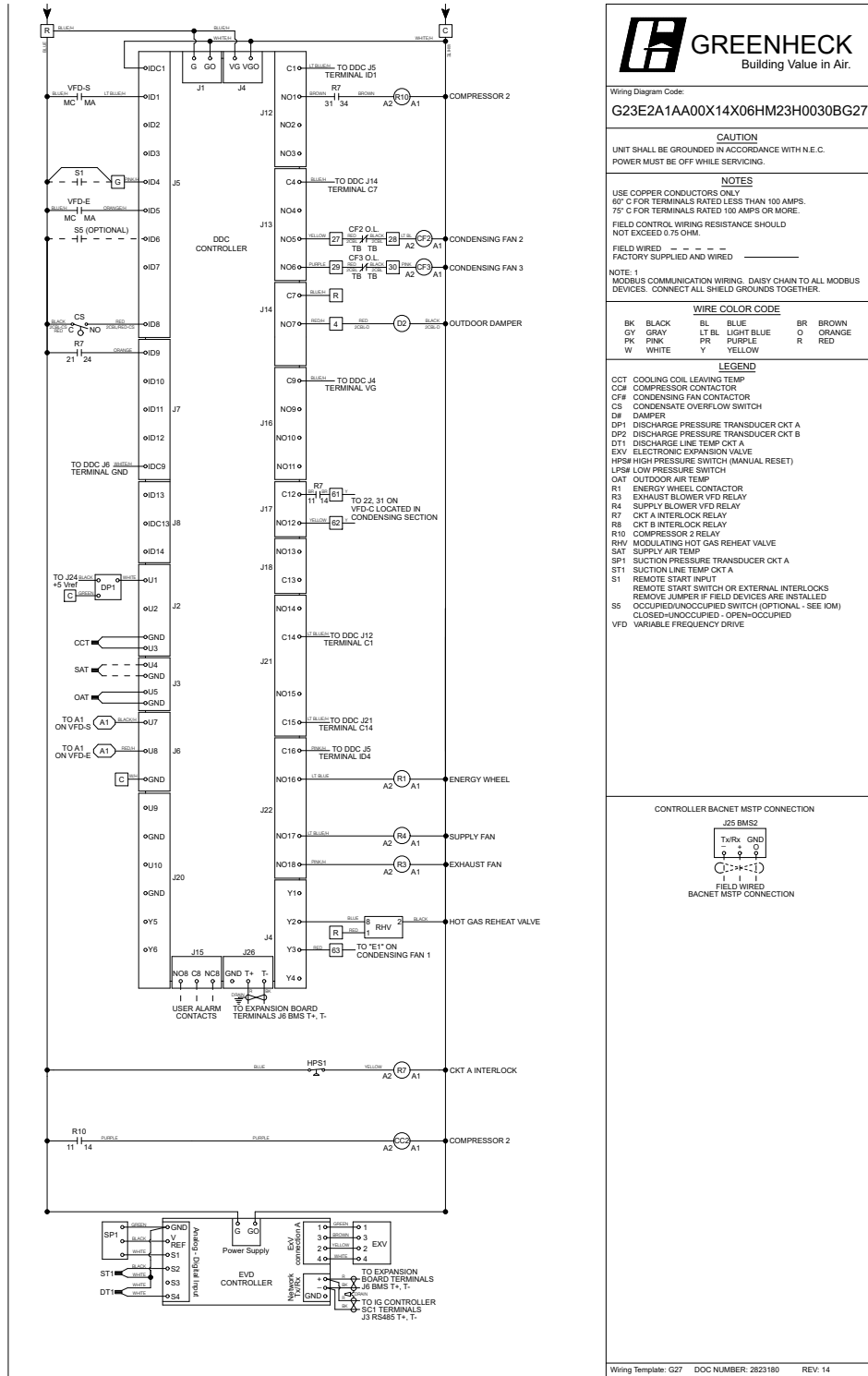

Wiring Diagram 3

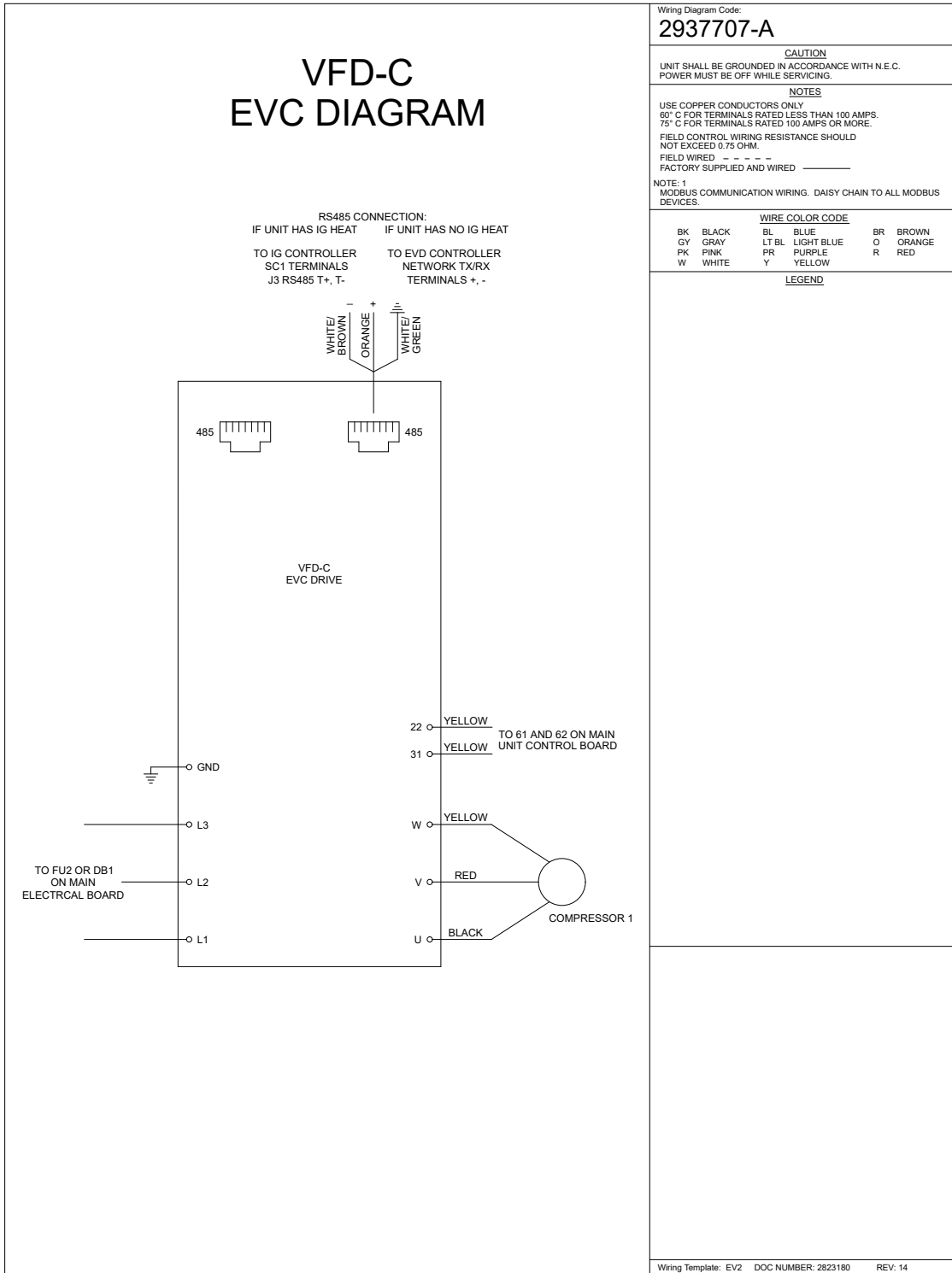

INDIRECT GAS WIRING DIAGRAM
FURNACE 1 - HTD MODULATING

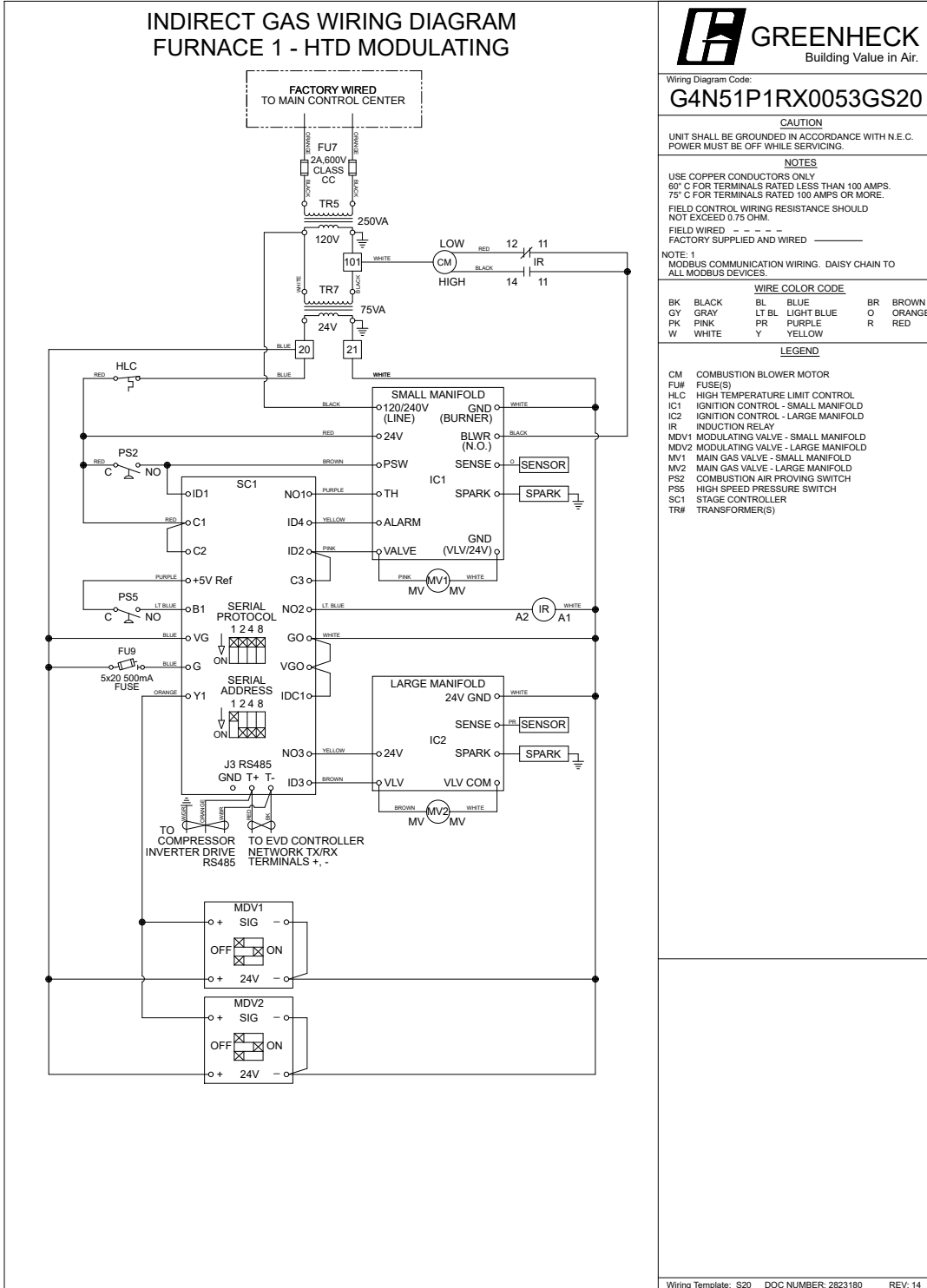

Wiring Diagram Code:
G4N51P1RX0053GS20

CAUTION
UNIT SHALL BE GROUNDED IN ACCORDANCE WITH N.E.C.
POWER MUST BE OFF WHILE SERVICING.

NOTES
USE COPPER CONDUCTORS ONLY
60° C FOR TERMINALS RATED LESS THAN 100 AMPS.
75° C FOR TERMINALS RATED 100 AMPS OR MORE.
FIELD CONTROL WIRING RESISTANCE SHOULD
NOT EXCEED 0.75 OHM.
FIELD WIRED - - - - -
FACTORY SUPPLIED AND WIRED _____

NOTE: 1
MODBUS COMMUNICATION WIRING. DAISY CHAIN TO
ALL MODBUS DEVICES.

WIRE COLOR CODE

BK	BLACK	BL	BLUE	BR	BROWN
GY	GRAY	LT BL	LIGHT BLUE	O	ORANGE
PK	PINK	PR	PURPLE	R	RED
W	WHITE	Y	YELLOW		

LEGEND

CM	COMBUSTION BLOWER MOTOR
FU#	FUSE(S)
HLC	HIGH TEMPERATURE LIMIT CONTROL
IC1	IGNITION CONTROL - SMALL MANIFOLD
IC2	IGNITION CONTROL - LARGE MANIFOLD
IR	INDUCTION RELAY
MDV1	MODULATING VALVE - SMALL MANIFOLD
MDV2	MODULATING VALVE - LARGE MANIFOLD
MV1	MAIN GAS VALVE - SMALL MANIFOLD
MV2	MAIN GAS VALVE - LARGE MANIFOLD
PS5	HIGH SPEED PRESSURE SWITCH
SC1	STAGE CONTROLLER
TR#	TRANSFORMER(S)

Monitoring Points Wiring Diagram

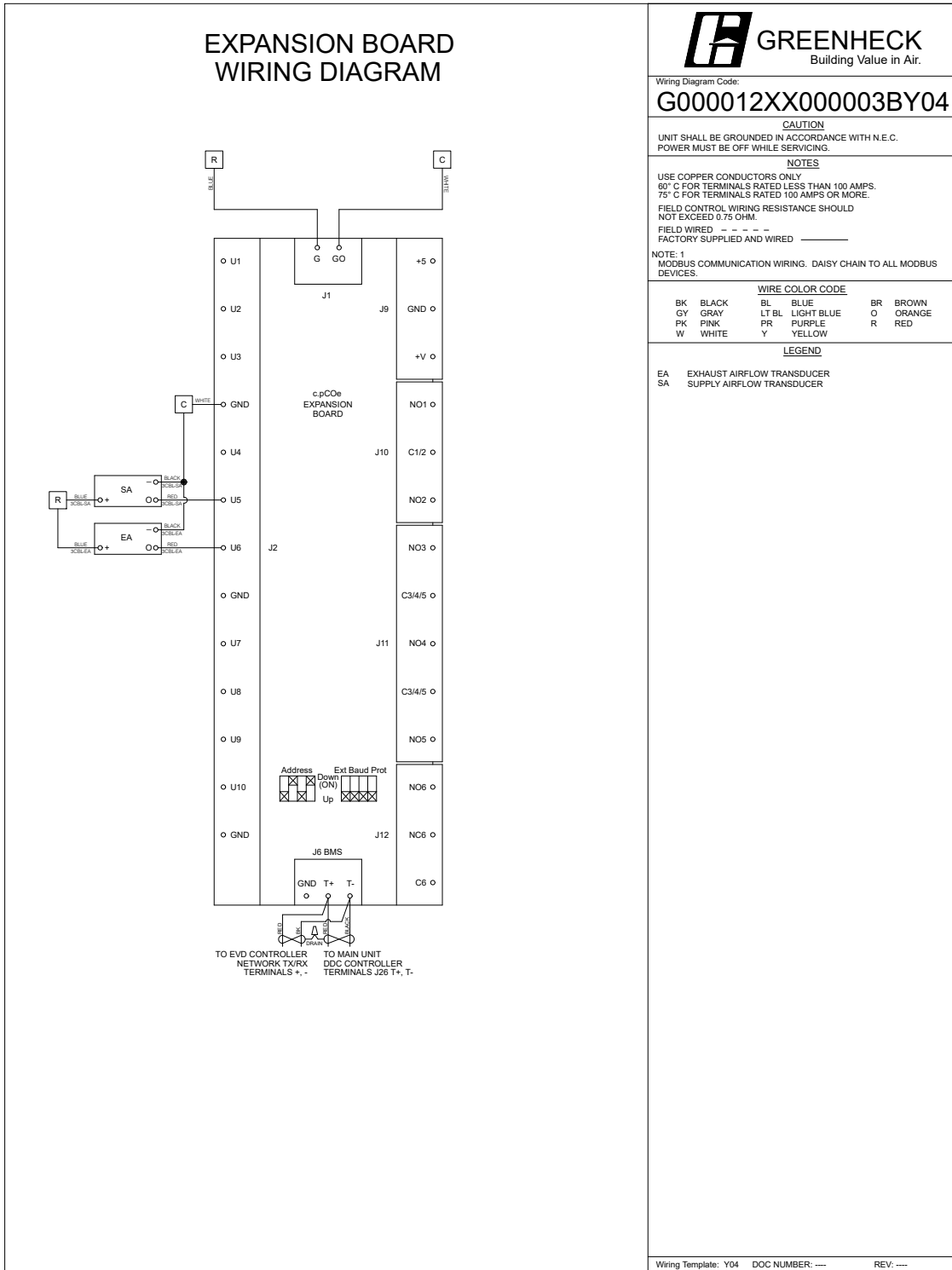

Factory Controller Sequence of Operation

FACTORY CONTROLLER: Controller shall be provided with required sensors and programming for rooftop unit. Controller shall be factory programmed, mounted and tested. Controller shall have a LCD readout for changing set points and monitoring unit operation.

UNIT START COMMAND (Unit will be enabled to start once a jumper is placed between R to G):

- Factory mounted and wired outdoor air damper actuator is powered
- Exhaust fan starts after a (adj.) delay.
- Supply fan starts after a (adj.) delay.
- Tempering options and energy wheel option to function as described below.

UNIT STOP COMMAND (OR DE-ENERGIZED):

- Supply fan, exhaust fan, energy wheel and tempering options de-energized.
- Outdoor air damper actuator is spring return close.

OCCUPIED/UNOCCUPIED MODES: Shall be based on a 7-day time clock internal to the controller. The schedule shall be set by the end user. When a user initiates an override input, the controller will switch from unoccupied to occupied mode. The controller will return to the scheduled occupied/unoccupied mode after the override time has expired. If internal time clock is disabled, a remote contact or a BMS can control the occupied/unoccupied mode.

Occupied Mode:

- Damper control per below.
- Energy wheel control per below.
- Exhaust fan ON.
- Supply fan ON.
- Heating per below.
- Cooling per below.

Unoccupied Mode (Unit Off): Unit remains off when in unoccupied mode.

- Supply fan OFF
- Exhaust fan OFF
- Tempering OFF
- Outdoor air damper closed.

MORNING WARMUP/COOL DOWN: Prior to occupancy, the unit will run using the warmup or cool down sequence until the occupied set point is achieved. The heating or cooling mode must not be locked out and the space temperature is below or above set point by the unoccupied hysteresis (adj.) (This Sequence must be field configured.)

SUPPLY BLOWER SEQUENCE: The supply blower is provided with a factory mounted variable frequency drive. The supply blower speed will be controlled with the following sequence.

Constant Volume-Adj. Setpoint: The supply blower will operate at a constant speed set point (adj.) during operation.

BMS Control: The supply blower is modulated based upon a command from the Building Management System. (This Sequence must be field configured.)

Outdoor Air Damper Control: The outdoor air damper is factory mounted and wired with a non-modulating actuator. When the unit is enabled/occupied the outdoor air damper will open to 100%

EXHAUST BLOWER SEQUENCE: The exhaust blower is provided with a factory mounted variable frequency drive. The exhaust blower speed will be controlled with the following sequence.

Constant Volume-Adj. Setpoint: The exhaust blower will operate at a constant speed set point (adj.) during operation.

BMS Control: The exhaust blower is modulated based upon a command from the Building Management System. (This sequence must be field configured.)

COOLING SEQUENCE: The cooling is controlled to maintain the supply temperature set point. The mechanical cooling will be locked out when the outside air is < 55 F (adj.).

Packaged DX Cooling (Inverter Scroll): The controller will provide a modulating signal for cooling. From 0-50%, the inverter scroll will be controlled to maintain discharge temperature. From 50-100% the second stage will be on in combination with the inverter scroll compressor to maintain the discharge temperature. The electronic expansion valve will modulate to maintain 8.0 F of superheat.

Modulating Hot Gas Reheat Sequence: During dehumidification the modulating HGRH is controlled to maintain the supply temperature set point.

Modulating Head Pressure Control: Lead condenser fan will have an EC motor and will modulate to maintain a head pressure set point.

DEHUMIDIFICATION CONTROL SEQUENCE: The cooling is controlled to maintain the cooling-coil set point. The dehumidification sequence will be locked out when the OA is < 10 F(adj.) above the cold-coil set point (adj.).

Cold Coil Set Point Control: The controller will control the cooling to maintain a cold coil set point. The active set point will set to local control (55 F, adj.) from the factory and can be field adjusted locally or by the BMS.

REHEAT SEQUENCE: While the unit is in dehumidification mode the outdoor air will be reheated via Modulating Hot Gas Reheat for space neutral applications.

Modulating Hot Gas Reheat: The controller will modulate the hot gas reheat valve with a 0-10 V signal to maintain the supply temperature set point (adj.).

HEATING SEQUENCE: The heating is controlled to maintain the supply temperature set point. The heating will be locked out when the outside air is > 80 F (adj.). Maximum allowable discharge air set point is 100 F.

Indirect Gas Furnace: The controller will modulate the indirect gas furnace to maintain the supply temperature set point (adj.).

TEMPERATURE CONTROL SEQUENCE: The unit will maintain the supply air discharge setpoint per the following. Adjustable locally or by BMS.

Supply Discharge Temperature Control: The supply setpoint will be a constant temperature setpoint from the controller (adj.). Adjustable locally or by BMS.

BUILDING FREEZE PROTECTION: If the supply air temperature drops below 35 F (adj.) for 300s (adj.), the controller will de-energize the unit and activate the alarm output.

TEMPERATURE PROTECTION: The controller will enable the supply fan to modulate down to help the unit keep up with heating demand in the event of wheel failure or the unit operating outside design conditions. (This can be enabled under the manufacturer menu in the controller)

ALARMS INDICATION: The controller will display alarms and have one digital output for remote indication of an alarm condition. Possible alarms include:

Building Management System: The controller will send all alarms to the BMS.

Supply and Exhaust Air Alarm: The controller monitors the proving switch on each blower and sends an alarm in the case of either blower proving switch not engaging.

DX Alarm: The controller monitors the refrigerant pressure. In the case of low refrigerant pressure the compressors will shut down until refrigerant pressure returns to normal values and the controller will send an alarm. In the case of high refrigerant pressure the compressors will shut down, requiring a manual reset and the controller will send a alarm.

Temperature Sensor Alarm: The controller sends an alarm in the case of a failed air temperature sensor.

ACCESSORIES: The following accessories will be included with the unit to expand the functionality or usability of the controller.

BMS Interfacing: A BMS port or serial card is provided with the controller for field interfacing with a building management system. Each card is sent out with the default parameters, and the controls contractor must change the appropriate addresses to match the BMS settings.

Phase and Brownout Protection: Factory mounted and wired component which monitors the main power coming into the unit. If a phase drops out, or if the incoming voltage exceeds the acceptable range, the component will turn off the unit to help protect the electrical systems.

Condensate Overflow Unit Shutdown: Factory mounted condensate overflow switch wired to the unit controller. The controller monitors the condensate overflow switch. If the water level in the drain pan reaches a certain level, the unit will shutdown and send an alarm.

Airflow Monitoring: The supply and exhaust fans will each have an airflow monitoring pressure tap on the inlet cone. The differential pressure across the fan cone is converted to an airflow reading by using the energy conservation principle and the fan wheel K-factor. The airflow can be monitored via the LCD and BAS.

Warranty Statement for Dedicated Outdoor Air Systems (DOAS)

Unit Warranty

Greenheck warrants the equipment to be free from defects in material and workmanship for a period of 18 months from ship date. Initial startup must be completed within six months of the shipment date, and a startup report must be submitted to Greenheck.

Energy Wheel Warranty

The energy recovery wheel is warranted to be free from defects in material and workmanship for a period of 5 years from the shipment date. This warranty applies to all parts and components in the energy recovery cassettes with the exception of the motor.

Heat Exchanger Extended Warranty

Greenheck warrants the stainless steel heat exchanger to be free from defects in material and workmanship for a period of 25 years from the shipment date.

Compressor Extended Warranty

Greenheck warrants the refrigerant compressor(s) to be free from defects in material and workmanship for a period of 5.5 years from the shipment date.

Warranty Notes

Any component which proves defective during the warranty period will be repaired or replaced at Greenheck's sole option when returned to our factory, transportation prepaid. All warranties do not include labor costs associated with troubleshooting, removal, or installation. Greenheck will not be liable for any consequential, punitive, or incidental damages resulting from use, repair, or operation of any Greenheck product. These warranties are exclusive and are in lieu of all other warranties, whether written, oral, or implied, including the warranty of merchantability and the warranty of fitness for a particular purpose. No person (including any agent or salesperson) has authority to expand Seller's obligation beyond the terms of this warranty, or to state that the performance of the product is other than that published by Seller.

As a result of our commitment to continuous improvement, Greenheck reserves the right to change specifications without notice.

PACKAGED HVAC UNIT IS HEAVIER THAN THE SPECIFIED UNIT. STRUCTURAL IS REVIEWING THE WEIGHT IMPACTS WITH THAT OF THE EXISTING ROOF STRUTURE. MODIFICATIONS MAY NEED TO BE MADE TO THE ROOF CURB TO ACCOMODATE THE ADDITIONAL WEIGHT.

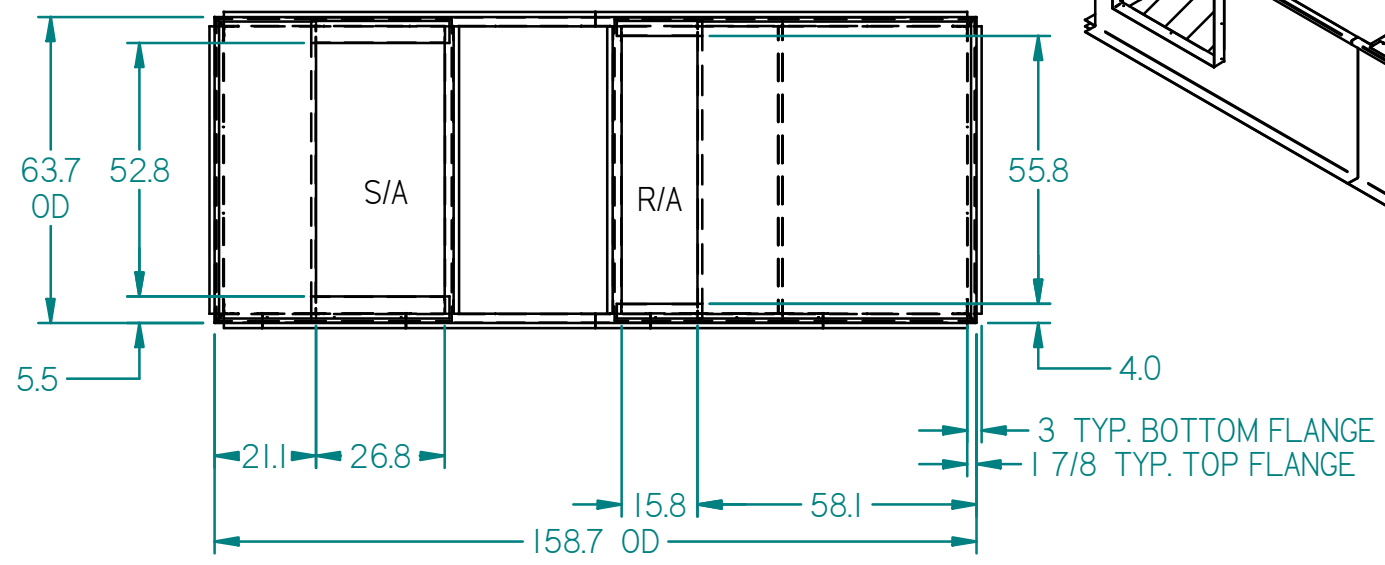
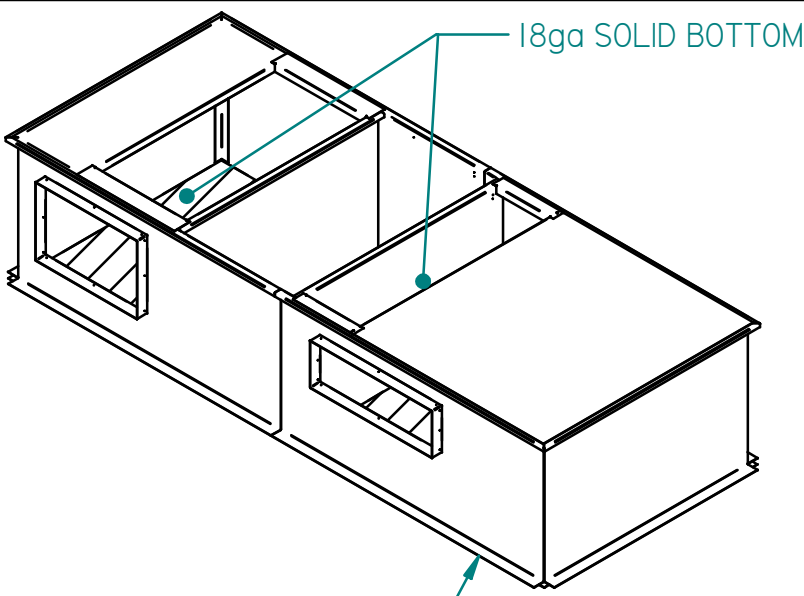

APPROX. WEIGHT
825 LBS

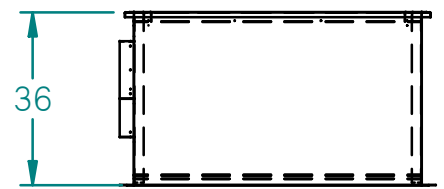
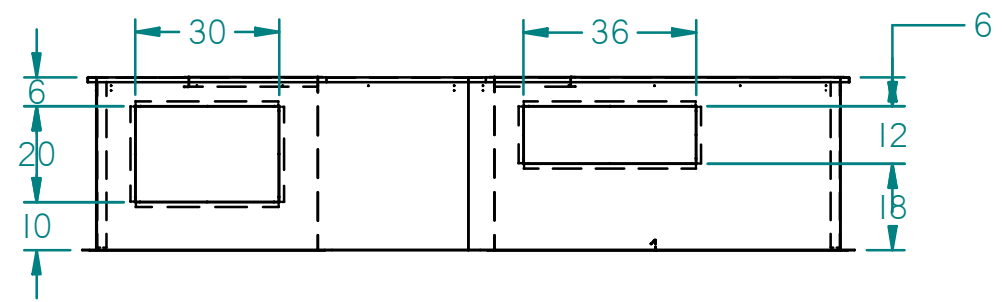

NOTES:

1. CURB SHIPPED WELDED, ONE PIECE
2. CURB MUST BE INSTALLED SQUARE AND LEVEL
3. MATERIAL IS GALVANIZED 14ga STEEL
4. FACTORY INSTALLED P.T. 2x4 WOOD NAILER
5. SUPPLIED WITH 1-1/2x1/4" CLOSED CELL NEOPRENE GASKET
6. INSULATED WITH 1" DUCT LINER

	CURB TECHNOLOGIES™	
QUANTITY: DIMENSIONS: INCHES	PROJECT: UNIT TAG:	
DRAWN BY JAS	MODEL: Y_SOLUTION XT0-	Rev. 00 ??/??/??

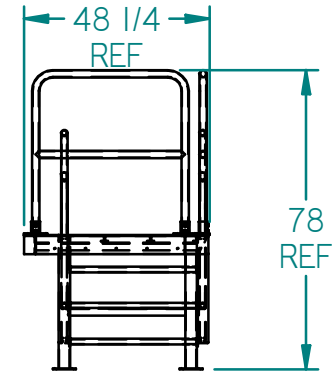
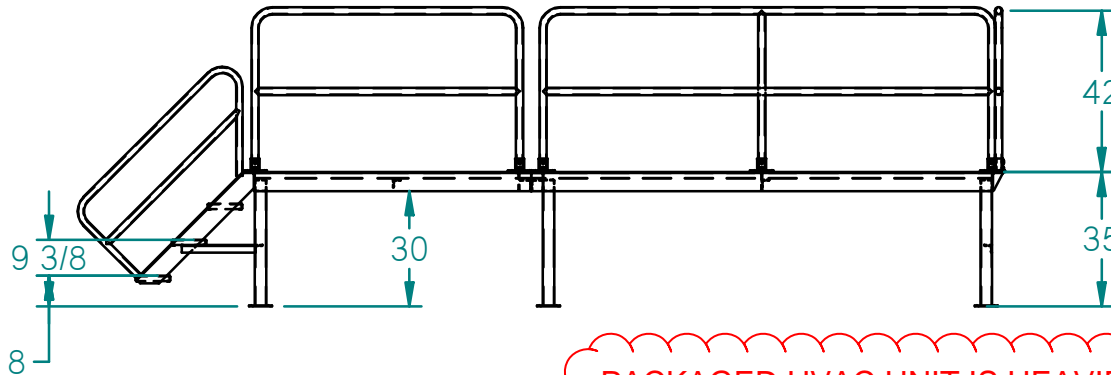
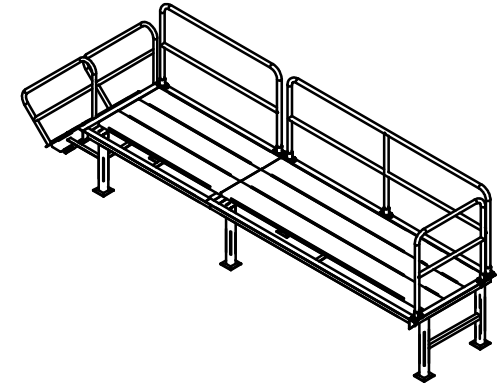
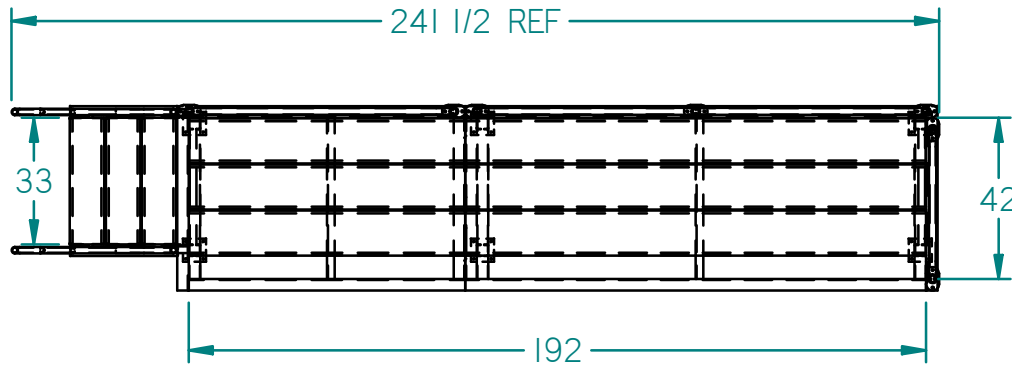

NOTES

1. PLATFORM SHIPPED IN WELDED SECTIONS FOR FIELD ASSEMBLY
2. MATERIAL IS STEEL, PRIMED ONLY. TOP COAT RECOMMENDED BY OTHERS
3. PLATFORM MAY BE BOLTED OR WELDED TO ROOF STRUCTURE
4. WALKING SURFACE IS GALVANIZED GRIP-STRUT
5. HAND RAILS ARE GALVANIZED 1-1/2" PIPE AND FULLY REMOVEABLE
6. HAND RAILS SHIPPED LOOSE

PACKAGED HVAC UNIT IS HEAVIER THAN THE SPECIFIED UNIT. STRUCTURAL IS REVIEWING THE WEIGHT IMPACTS WITH THAT OF THE EXISTING ROOF STRUTURE. MODIFICATIONS MAY NEED TO BE MADE TO THE ROOF CURB TO ACCOMODATE THE ADDITIONAL WEIGHT.

	CURB TECHNOLOGIES™		
QUANTITY: 1 DIMENSIONS: INCHES	PROJECT: ATU Jones Hall (220606-TG34) UNIT TAG: MODEL: CTCW-1		
DRAWN BY THD	<table border="1" style="display: inline-table; border-collapse: collapse;"> <tr> <td style="padding: 2px;">Rev. 00</td> <td style="padding: 2px;">9/26/22</td> </tr> </table>	Rev. 00	9/26/22
Rev. 00	9/26/22		