

Quality People. Building Solutions.

Comfort Systems USA (Arkansas), Inc.
P.O. Box 16620
Little Rock, AR 72231
Phone 501-834-3320
Fax 501-834-5416

Date: 5/17/2024
Return Request: 5/27/2024
Project: CALS Main Library Renovations
Supplier: Comfort Systems USA (Arkansas), Inc.
Manufacturer: Trerice
Submittal: Meters & Gauges (Plumbing)
Submittal Number: 22 05 19-01
Drawing # and Installation: Plumbing Drawings

ARCHITECT

Polk Stanley Wilcox
801 South Spring St.
Little Rock, AR 72201
501-378-0878

ENGINEER

Bernhard
1 Allied Drive, Bldg. 2, Suite 2600
Little Rock, AR 72202
501-666-6776

GENERAL CONTRACTOR

CDI
3000 Cantrell Rd.
Little Rock, AR 72202
501-5666-4300

MECHANICAL SUBCONTRACTOR

Comfort Systems USA (Arkansas), Inc.
9924 Landers Rd.
N. Little Rock, AR 72117
501-834-3320

Notes:

CSUSA PROJECT NO.

23-8016

dpierce@comfortar.com

9924 Landers Rd.
No. Little Rock, AR 72117

Adjustable Angle

7" • 9" • 12" Scale Sizes

INDUSTRIAL THERMOMETERS

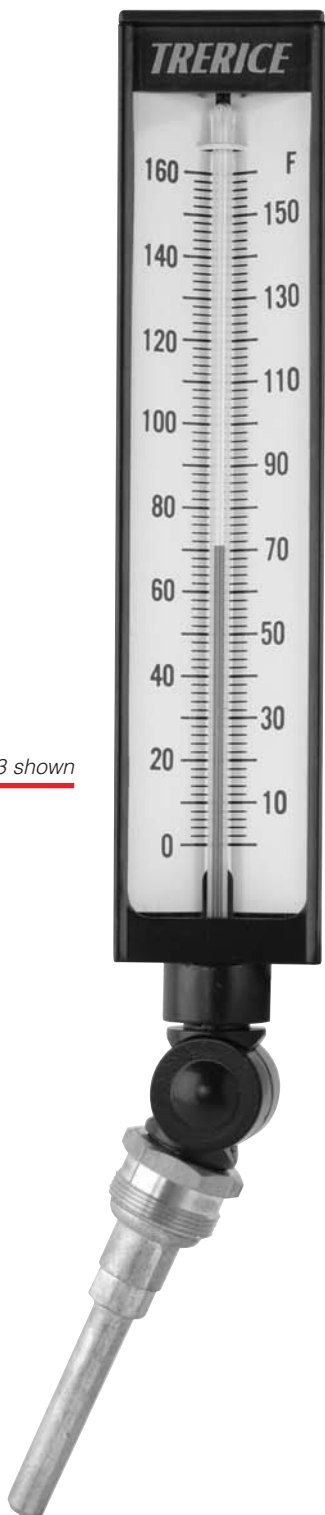

BX91403 shown

- ▶ 7", 9", 12" Scale
- ▶ ± 1 Scale Division Accuracy
- ▶ Cast Aluminum Case
- ▶ Adjustable Angle Stem

Recognized globally as the Trerice "BX" Industrial Thermometer, this is an instrument of extreme accuracy and rugged dependability. Available in scale sizes of 7" (AX9), 9" (BX9), & 12" (CX9), with a durable cast aluminum case, this universally adjustable, liquid-in-glass thermometer is the most widely specified instrument of its kind.

- Optional features available: Please consult the Options & Accessories Section for details.

Thermowell

- For applications where the process media may be corrosive or contained under pressure, the use of a thermowell is required to prevent damage to the thermometer and facilitate its removal from the process. (Refer to page 152)

Specifications

Models	Scale Sizes	
AX9	7"	Adjustable Angle
BX9	9"	
CX9	12"	
Fill Type		Spirit: Blue colored, organic
Case		Cast Aluminum, blue epoxy finish
Stem		Aluminum, brass, 304 stainless steel or air-duct style available
Connection		Standard: 11/4-18 UNEF-2A coupling nut Air-Duct: Reversible mounting flange with 3 bolt holes
Window		Acrylic on ranges to 300° F Glass on ranges over 300° F
Tube		Lens front, magnifying type
Scale		Aluminum, white background with black graduations and markings
Top Plate		ABS
Accuracy		±1 scale division
Approximate Shipping Weight		
AX9: 1.5 lbs [0.68 kg]		
BX9: 1.6 lbs [0.73 kg]		
CX9: 2.0 lbs [0.91 kg]		

HOW TO ORDER

Sample Order Number: **BX9 1 403 07**

Model	Stem (Material)	Stem (Length)	Specific Range
AX9 7" Adjustable	1 Aluminum (standard)	403 3 1/2"	See Standard Ranges
BX9 9" Adjustable	2 Brass	406 6"	
CX9 12" Adjustable	3 304 SS	408 8"	
		512 12"	
	9 Air-Duct (Aluminum)*	006 6" Air-Duct	
		012 12" Air-Duct	

* Not for use with Thermowells

Adjustable Angle

All dimensions are nominal.
Dimensions in [] are in millimeters.

INDUSTRIAL THERMOMETERS

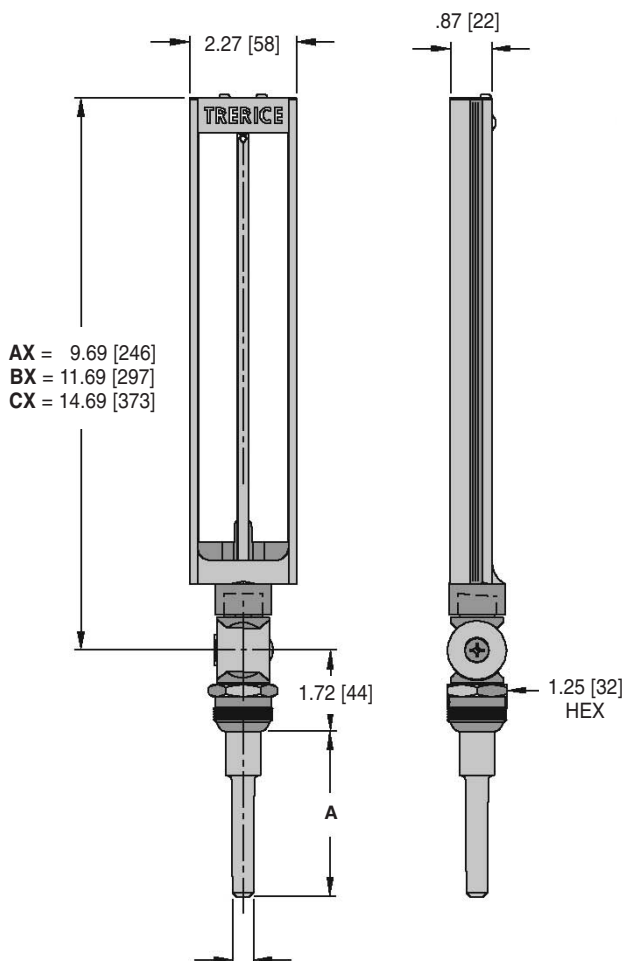

(A) Stem Length	Dimension
3 1/2"	3.50 [88.9]
6"	6.00 [152.4]
8"	8.00 [203.2]
12"	12.00 [304.8]

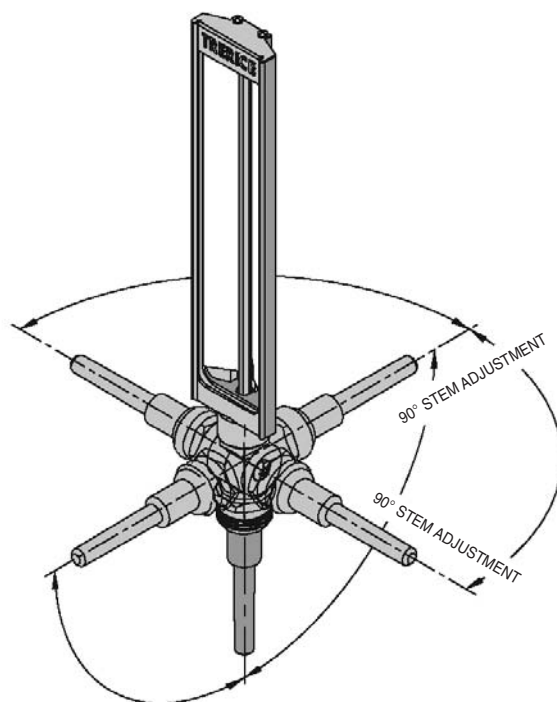
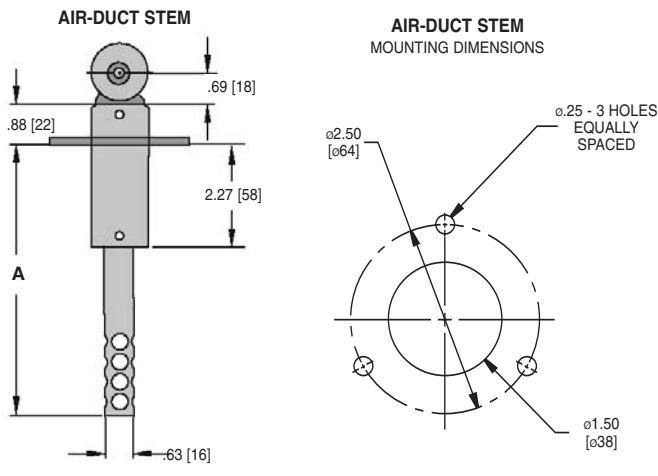

Standard Ranges

Fahrenheit Scale		Celsius Scale		Dual Scale		Fahrenheit		Celsius	
Range Code	Range	Range Code	Range	Range Code	Range	Figure Intervals	Minor Divisions	Figure Intervals	Minor Divisions
01	-40° to 110°F	17	-40° to 40°C	41	-40° to 110°F & -40° to 40°C	10°	2°	5°	1°
02	0° to 100°F	24	-18° to 38°C	42	0° to 100°F & -18° to 38°C	5°	1°	5°	0.5°
03	30° to 130°F	25	0° to 55°C	43	30° to 130°F & 0° to 55°C	5°	1°	5°	1°
04	0° to 160°F	26	-18° to 70°C	44	0° to 160°F & -18° to 70°C	10°	2°	5°	1°
06	30° to 180°F	27	0° to 83°C	46	30° to 180°F & 0° to 83°C	10°	2°	5°	1°
07	30° to 240°F	19	0° to 115°C	47	30° to 240°F & 0° to 115°C	10°	2°	5°	1°
08	30° to 300°F	20	0° to 150°C	48	30° to 300°F & 0° to 150°C	10°	2°	10°	2°
09	50° to 400°F	28	10° to 205°C	49	50° to 400°F & 10° to 205°C	25°	5°	10°	2°
15	50° to 500°F	31	10° to 260°C	55	50° to 500°F & 10° to 260°C	25°	5°	10°	2°

Dual scale figure intervals may differ

Thermowells

for Industrial Thermometers

All dimensions are nominal. Dimensions in [] are in millimeters.

THERMOWELLS

- SX9 Solar
- AX9, BX9, CX9 Adjustable Angle
- AX, BX, CX Rigid Stem
- BX Plus

Lengths

(A) Stem Length	Standard	with Lagging Extension	
	U Length	(T)	U Length
3 1/2"	2.50 [64]	1.00 [25]	1.70 [43]
6"	5.00 [127]	2.50 [64]	2.50 [64]
8"	7.00 [178]	2.50 [64]	4.50 [114]
12"	10.50 [267]	3.00 [76]	7.50 [191]

Pressure Rating (psi)

Material	Operating Temperature			
	70°F	200°F	400°F	600°F
Brass	640	575	100	—
Carbon Steel	720	690	660	630
304 Stainless Steel	940	850	770	740
316 Stainless Steel	940	940	875	850
Monel	900	825	740	730

Standard

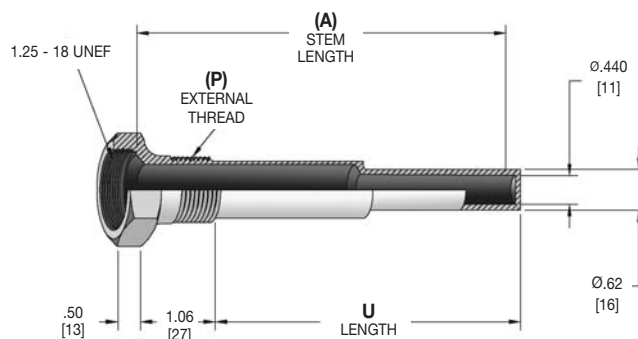

with Lagging Extension

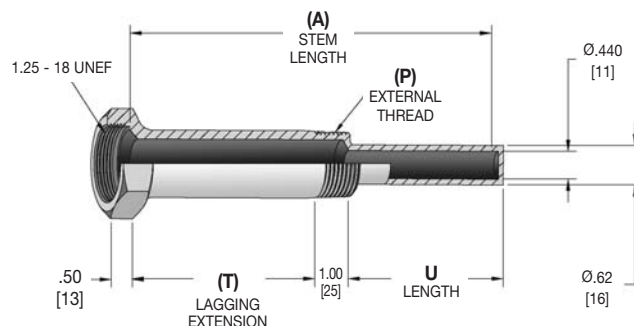

Alternative materials and accessories are also available. Please consult the Options and Accessories Section for details.

Selection of the proper thermowell is the sole responsibility of the user. Temperature and pressure limitations must be considered. Improper application may cause failure of the thermowell, resulting in possible personal injury or property damage.

HOW TO ORDER

Sample Order Number: **3-4 F 2**

Thermowell Style	(P) External Thread	(A) Stem Length	(T) Lagging Extension	Material
3- Industrial	3 1/2 NPT*	F 3 1/2" Stem**	A 1" Extension (3 1/2" Stem only)	2 Brass
	4 3/4 NPT	J 6" Stem	D 2 1/2" Extension (6" and longer Stem only)†	3 Steel
	5 1 NPT	L 8" Stem	Omit if None	4 Monel
		R 12" Stem		5 304SS
				6 316SS

* Only available with 3 1/2" stem and 1" extension.

** 3 1/2" stem Straight Shank.

† 3" extension on 12" stem.

600CB

Cast Aluminum Case

COMMERCIAL • CONTRACTOR GAUGES



600CB shown

- ▶ 3 1/2" & 4 1/2" Dial Sizes
- ▶ ±1.0% Accuracy
- ▶ Cast Aluminum Case
- ▶ Adjustable Pointer

The **600CB** Trerice Contractor Gauge is among the most frequently specified HVACR gauges within the construction industry. This gauge offers high reliability at a moderate price. The 600CB is furnished with a cast aluminum case and an adjustable pointer.

- Optional features and case style variations available: Please consult the Options & Accessories Section for details.
- For correct use and application of all pressure gauges, please refer to: Pressure Gauge Standard ASME B40.100 .

Specifications

Model	600CB
Dial Sizes	3 1/2", 4 1/2"
Wetted Parts	3 1/2" Dial Size: Bronze tube, brass socket 4 1/2" Dial Size: Brass tube & socket
Movement	Brass
Connection	Lower male, 1/4 NPT
Case	Cast aluminum, black finished, stem-mounted flangeless
Ring	3 1/2" Dial Size: Friction type, steel, black finished 4 1/2" Dial Size: Friction type, 304 stainless steel
Window	Clear glass
Pointer	Adjustable, black finished
Dial Face	Aluminum, white background with black graduations and markings
Accuracy	±1.0% Full Scale, ASME B40.100 Grade 1A
Maximum Temperature	250°F (121°C)
Approximate Shipping Weight	3 1/2" Dial Size: 0.7 lbs [0.32 kg] 4 1/2" Dial Size: 1.1 lbs [0.50 kg]

HOW TO ORDER

Sample Order Number: **600CB 35 02 L A 090**

Model	Dial Size	Connection Size	Connection Location	Units of Measure	Range Code
600CB	35 3 1/2"	02 1/4 NPT	L Lower	A psi	See Standard Ranges
	45 4 1/2"			B kPa	
				C kg/cm ²	
				D psi/kPa	
				E psi & kg/cm ²	

600CB

Cast Aluminum Case

All dimensions are nominal. Dimensions in [] are in millimeters.

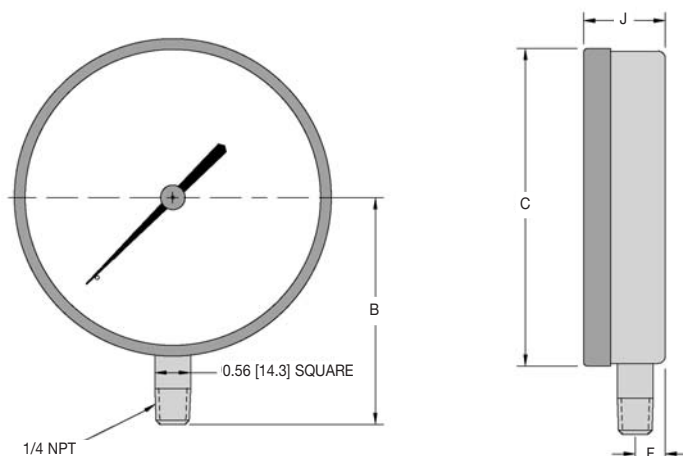

Dial Size	B	C	F	J
3 1/2"	3.06 [77.8]	3.88 [98.6]	0.44 [11.2]	1.22 [31]
4 1/2"	3.54 [89.9]	4.96 [126]	0.47 [11.9]	1.28 [32.5]

COMMERCIAL • CONTRACTOR GAUGES

Standard Ranges

psi Ranges (A)				kPa Ranges (B)				kg/cm ² Ranges (C)			
Range Code	Specific Range (psi)	Figure Intervals	Minor Divisions	Range Code	Specific Range	Figure Intervals	Minor Divisions	Range Code	Specific Range	Figure Intervals	Minor Divisions
010	30" Hg to 0	5	0.5	010	-100 to 0 kPa	10	1	010	76 cm Hg to 0	10	0.5
020	30" Hg to 15 PSI	10/5	0.5/0.5	020	-100 to 100 kPa	20	2	020	76 cm Hg to 1 kg/cm ²	20/0.2	1/.02
030	30" Hg to 30 PSI	10/5	1/1	030	-100 to 200 kPa	50	2	030	76 cm Hg to 2 kg/cm ²	20/0.5	2/.02
040	30" Hg to 60 PSI	10/10	2/1	040	-100 to 400 kPa	50	5	040	76 cm Hg to 4 kg/cm ²	25/0.5	5/0.5
050	30" Hg to 100 PSI	30/20	2/2	050	-100 to 700 kPa	100	5	050	76 cm Hg to 7 kg/cm ²	76/1	5/0.1
060	30" Hg to 150 PSI	30/20	5/2	060	-100 to 1000 kPa	100	10	060	76 cm Hg to 10 kg/cm ²	76/1	15/0.1
070	30" Hg to 300 PSI	30/50	5/5	070	-100 to 2000 kPa	200	20	070	76 cm Hg to 21 kg/cm ²	76/2	19/0.2
080	0 to 15 PSI	3	0.2	080	0 to 100 kPa	10	1	080	0 to 1 kg/cm ²	0.1	0.01
090	0 to 30 PSI	5	0.5	090	0 to 200 kPa	20	2	090	0 to 2 kg/cm ²	0.2	0.02
100	0 to 60 PSI	10	1	100	0 to 400 kPa	50	5	100	0 to 4.2 kg/cm ²	0.5	0.05
110	0 to 100 PSI	10	2	110	0 to 700 kPa	100	5	110	0 to 7 kg/cm ²	1	0.05
120	0 to 160 PSI	20	2	120	0 to 1200 kPa	200	10	120	0 to 11 kg/cm ²	1	0.1
130	0 to 200 PSI	20	2	130	0 to 1500 kPa	300	10	130	0 to 14 kg/cm ²	2	0.1
140	0 to 300 PSI	50	5	140	0 to 2000 kPa	200	20	140	0 to 21 kg/cm ²	3	0.2
150	0 to 400 PSI	50	5	150	0 to 3000 kPa	300	20	150	0 to 28 kg/cm ²	4	0.2
160	0 to 600 PSI	100	10	160	0 to 4000 kPa	500	50	160	0 to 42 kg/cm ²	6	0.5
180	0 to 1000 PSI	100	20	180	0 to 7000 kPa	1000	50	180	0 to 70 kg/cm ²	10	0.5

For dual scale ranges, specify the appropriate Units of Measure: **D** (psi/kPa) or **E** (psi & kg/cm²) followed by the equivalent **A** (psi) Range Code. Other pressure ranges are also available including: Altitude, Ammonia, Refrigerant and Receiver. Consult Special Application Ranges section or factory for availability.

865/880 Series

Gauge Cocks

865/880 Series Quarter Turn Gauge Cocks provide an economical way to shut off the flow of air to the pressure instrument, thereby allowing the instrument to be isolated from the pressure media or removed from service. Trerice Gauge Cocks are constructed from brass and are intended for use on air lines where leakage is not of concern. **It is recommended to place a needle valve, ball valve or gauge cock in line before every pressure gauge installation.**

In applications where process media leakage may result in possible personal injury or property damage, gauge cocks should not be specified as they contain no packing gland and leakage may result. For tight shut-off and prevention of leakage, use of a Trerice Ball Valve or Needle Valve is required.



865/880 Series Gauge Cocks

Item No.	Type	Connection Size	Body	Plug	Maximum Pressure (psig)	Maximum Temperature	Approximate Shipping Weight
865	FXF	1/4 NPT	Brass*	Brass	200	500°F	0.1 lbs [0.05 kg]
865MFG	MXF	1/4 NPT	Brass*	Brass	200	500°F	0.1 lbs [0.05 kg]
865-1	FXF	1/4 NPT	Brass	Brass	300	500°F	0.3 lbs [0.14 kg]
880	MXF	1/4 Union	Brass	Brass	150	500°F	0.5 lbs [0.23 kg]

* Add (PBF) to the end of part number to specify Lead-Free brass.

All dimensions are nominal. Dimensions in [] are in millimeters.

Part No.	A	B	C	NPT
865	1.09 [28]	1.73 [44]	1.62 [41]	1/4 - 18
865-1	1.04 [26]	1.78 [45]	2.26 [41]	1/4 - 18
865MFG	1.09 [28]	1.73 [44]	1.86 [47]	1/4 - 18
880	1.12 [28]	1.82 [46]	3.31 [84]	1/4 - 18

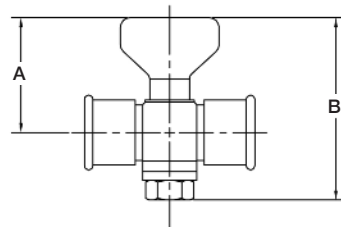
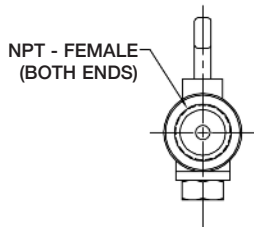
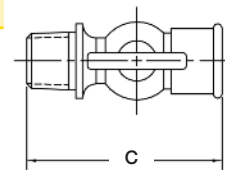
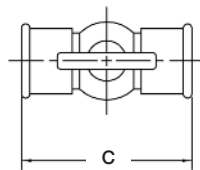

865 & 865-1

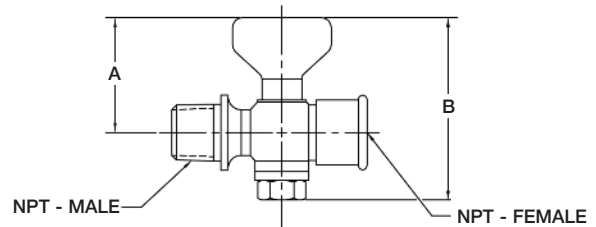

865MFG & 880

885 Series

Coil Syphons

885 Series Coil Syphons are designed for use on steam service to form a pocket of water between the pressure gauge and the process steam, thereby preventing the steam from reaching the bourdon tube of the pressure gauge. Trerice Coil Syphons are constructed of steel, brass, or 304 stainless steel with a 180° coil for use on a variety of requirements. Other materials and coil styles are available; consult factory.



885 Series Coil Syphons

Item No.	Material	Style	Connection Size (NPT)	Maximum Pressure (psig)	Maximum Temperature	Approximate Shipping Weight
885-1	Welded steel, schedule 40	180° coil	1/4	600	750°F	0.4 lbs [0.18 kg]
885-1.1	Seamless steel, schedule 40	180° coil	1/2	800	650°F	1.4 lbs [0.64 kg]
885-2	Seamless brass, schedule 40	180° coil	1/4	250	406°F	0.4 lbs [0.18 kg]
885-3	Chrome plated brass, schedule 40	180° coil	1/4	250	406°F	0.4 lbs [0.18 kg]
885-4	Seamless 304SS, schedule 40	180° coil	1/4	1300	650°F	0.4 lbs [0.18 kg]
885-4.1	Seamless 304SS, schedule 40	180° coil	1/2	1000	650°F	1.4 lbs [0.64 kg]
885-6	Seamless 316SS, schedule 40	180° coil	1/4	1300	650°F	0.4 lbs [0.18 kg]
885-6.1	Seamless 316SS, schedule 40	180° coil	1/2	1000	650°F	1.4 lbs [0.64 kg]

All dimensions are nominal. Dimensions in [] are in millimeters.

Part No.	A	NPT
885-1	4.3	1/4 - 18
885-1.1	9.0	1/2 - 14
885-2	5.6	1/4 - 18
885-3	5.6	1/4 - 18
885-4	5.6	1/4 - 18
885-4.1	9.0	1/2 - 14
885-6	4.3	1/4 - 18
885-6.1	9.0	1/2 - 14

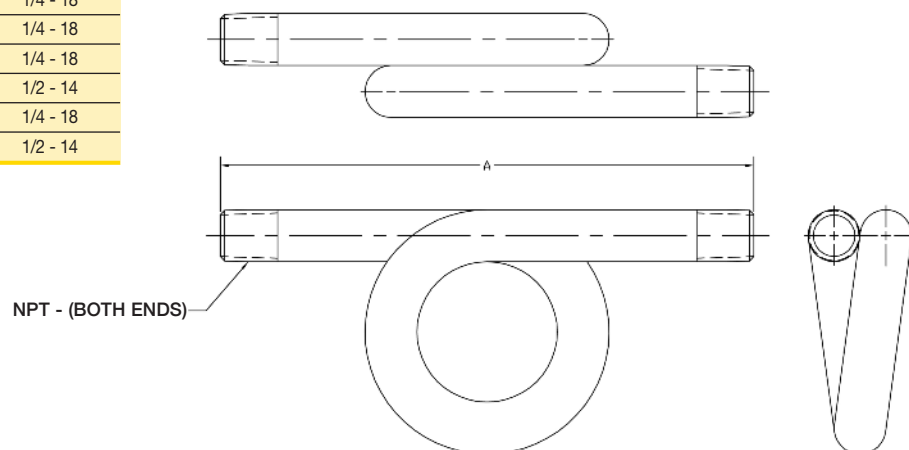

872 Series

Pressure Snubbers



872 Series Pressure Snubbers are designed to improve readability and prevent wear on delicate gauge mechanisms by slowing rapid pressure changes and reducing shock and chattering. A pressure snubber should be installed on a gauge in any application where pressure spikes and/or pulsations may be present. If a single snubber does not correct the oscillation, it is recommended to place an additional snubber in line with the first. Trerice Pressure Snubbers reduce the pulsation by forcing the pressure medium through a porous metal core and are constructed from brass or 303 stainless steel for use on a variety of pressure media.

872 Series Pressure Snubbers

Item No.	Body & Insert Material	Connection Size (NPT)	Maximum Pressure (psig)	Service	Approximate Shipping Weight
872-1	Brass*	1/4	1000	Air and gases	0.1 lbs [0.05 kg]
872-2	Brass*	1/4	1000	Water, steam, gasoline and light oils	0.1 lbs [0.05 kg]
872-3	Brass*	1/4	1000	Lubricating and heavy oils	0.1 lbs [0.05 kg]
872-4	303SS	1/4	2000	Air and gases	0.3 lbs [0.14 kg]
872-5	303SS	1/4	2000	Water, steam, gasoline and light oils	0.3 lbs [0.14 kg]
872-6	303SS	1/4	2000	Lubricating and heavy oils	0.3 lbs [0.14 kg]
872-7	Brass*	1/2	5000	Air and gases	0.1 lbs [0.05 kg]
872-8	Brass*	1/2	5000	Water, steam, gasoline and light oils	0.1 lbs [0.05 kg]
872-9	Brass*	1/2	5000	Lubricating and heavy oils	0.1 lbs [0.05 kg]
872-10	303SS	1/2	10,000	Air and gases	0.3 lbs [0.14 kg]
872-11	303SS	1/2	10,000	Water, steam, gasoline and light oils	0.3 lbs [0.14 kg]
872-12	303SS	1/2	10,000	Lubricating and heavy oils	0.3 lbs [0.14 kg]

* Add (PBF) to the end of part number to specify Lead-Free brass.

All dimensions are nominal. Dimensions in [] are in millimeters.

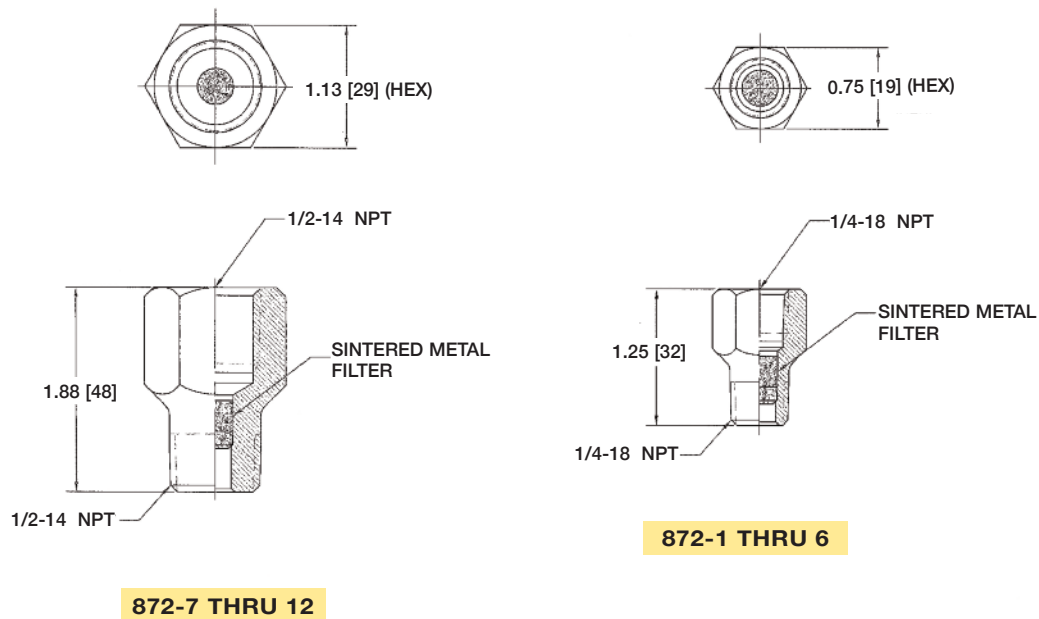

Test Plugs & Accessories

PRESSURE GAUGES

The **Trerice Test Plug** provides a convenient access port for determining the pressure and/or temperature of process media contained in a pipe line or vessel. The test plug is designed for use in chilled or hot water systems and is permanently installed in the system at the desired test location. A test thermometer or pressure gauge with test adapter can be inserted through the plug to determine the conditions within the system. When the probe is withdrawn, the inner valve plug closes to seal the system. The test plug includes a removable cap to protect the inner valve plug and provide a secondary seal.



D3742 shown

Nordel, otherwise known as EPDM, provides excellent service in hot or cold water. **Nordel should not be used with hydrocarbon solvents, hydrocarbon oils, chlorinated hydro carbons or turpentine.**

Neoprene, a synthetic rubber, provides excellent service in ammonia, high aniline point petroleum oils and silicate ester lubricants. **Neoprene should not be used with silicone greases, silicone oils or di-ester based lubricants.**

Test plugs are designed for initial startup and testing, not continuous or frequent use. If continuous or frequent use is desired or expected, a test well should be installed for temperature applications and a needle valve installed for pressure applications.

Tests should be made as quickly as possible because the inner plug resealing time is dependent upon the length of time the probe remains inserted, as well as the temperature and pressure of the system. The test plug may take longer to reseal at lower temperatures or pressures. The probe used for testing should never exceed a diameter of 0.156" (4 mm). The pressure gauge used for testing should always have a range of twice the system pressure.

Test Plugs

Test Plug Item No.	Test Plug with Retainer Item No.	Connection Size (NPT)	Body Length	Body & Cap	Core	Max Pres. (psig)	Max Temp.	Approximate Shipping Weight
D3741	D3764	1/4	1 1/2"	Brass*	Nordel	1000	350°F	0.1 lbs [0.05 kg]
D3743	D3763	1/4	1 1/2"	Brass*	Neoprene	1000	200°F	0.1 lbs [0.05 kg]
D3758	D3766	1/4	1 1/2"	316SS	Nordel	1000	350°F	0.1 lbs [0.05 kg]
D3757	D3765	1/4	1 1/2"	316SS	Neoprene	1000	200°F	0.1 lbs [0.05 kg]
D3742	D3770	1/2	1 1/2"	Brass*	Nordel	1000	350°F	0.2 lbs [0.09 kg]
D3744	D3769	1/2	1 1/2"	Brass*	Neoprene	1000	200°F	0.2 lbs [0.09 kg]
D3762	D3772	1/2	1 1/2"	316SS	Nordel	1000	350°F	0.2 lbs [0.09 kg]
D3761	D3771	1/2	1 1/2"	316SS	Neoprene	1000	200°F	0.2 lbs [0.09 kg]
D3767	D3773	1/4	3"	Brass	Nordel	1000	350°F	0.4 lbs [0.18 kg]
D3768	D3774	1/4	3"	Brass	Neoprene	1000	200°F	0.4 lbs [0.18 kg]

* Add (PBF) to the end of part number to specify Lead-Free brass.

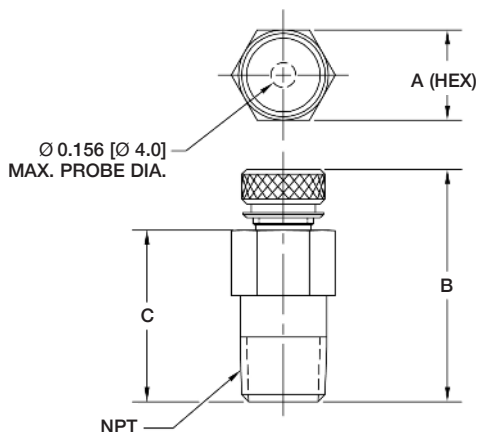

All dimensions are nominal. Dimensions in [] are in millimeters.

Part No.	A	B	C	NPT
D3741	0.56 [14]	1.50 [38]	1.06 [27]	1/4 - 18
D3743				
D3758				
D3757	0.88 [22]	1.50 [38]	1.06 [27]	1/2 - 14
D3742				
D3744				
D3762				
D3761	0.56 [14]	3.00 [76]	2.56 [65]	1/4 - 18
D3767				
D3768				

Test Plugs & Accessories

Test Kits

Item No.	Pressure Range (psi)	Approximate Shipping Weight
D3750	0 to 100	1.4 lbs [0.64 kg]
D3751	0 to 200	1.4 lbs [0.64 kg]
D3752	0 to 300	1.4 lbs [0.64 kg]
D3748	0 to 600	1.4 lbs [0.64 kg]

Each test kit contains:

- (1) 700B Pressure Gauge,
- (1) B82105P03F&C Thermometer,
- (1) B82105P05F&C Thermometer,
- (1) D3747 Gauge Adapter,
- (1) Carrying Case



Test Kit Replacement Items

Item No.	Description	Approximate Shipping Weight
700B2502LA110	700B Pressure Gauge, 2 1/2", 1/4 NPT, lower connection, 0 to 100 psi	0.4 lbs [0.18 kg]
700B2502LA130	700B Pressure Gauge, 2 1/2", 1/4 NPT, lower connection, 0 to 200 psi	0.4 lbs [0.18 kg]
700B2502LA140	700B Pressure Gauge, 2 1/2", 1/4 NPT, lower connection, 0 to 300 psi	0.4 lbs [0.18 kg]
700B2502LA160	700B Pressure Gauge, 2 1/2", 1/4 NPT, lower connection, 0 to 600 psi	0.4 lbs [0.18 kg]
B82105P03	B82105 Bimetal Thermometer, 1 3/4" dial size, 5" stem, 25° to 125°F & C	0.4 lbs [0.18 kg]
B82105P05	B82105 Bimetal Thermometer, 1 3/4" dial size, 5" stem, 20° to 240°F & C	0.4 lbs [0.18 kg]

Accessories

Item No.	Description	Approx. Shipping Weight
D3747	Gauge Adapter, 1/8" diameter	0.1 lbs [0.05 kg]
D3749*	2" Brass Extension, 1/4 NPT	0.1 lbs [0.05 kg]
D3753*	2" Brass Extension, 1/2 NPT	0.2 lbs [0.09 kg]

* Add (PBF) to the end of part number to specify Lead-Free brass.