

Quality People. Building Solutions.

Comfort Systems USA (Arkansas), Inc.
P.O. Box 16620
Little Rock, AR 72231
Phone 501-834-3320
Fax 501-834-5416

Date: 10/18/2024

Return Request: 11/1/2024

Project: UAMS (CAMID)

Supplier: Comfort Systems USA (Arkansas), Inc.

Manufacturer: ASC

Submittal: HVAC Hangers & Supports

Submittal Number: 23 05 29-01

Drawing # and Installation: Mechanical Drawings

ARCHITECT

Clark Kenersen
2020 Baltimore Avenue, Suite 300
Kansas City, MO 64108
816-474-8237

ENGINEER

Clark Kenersen
2020 Baltimore Avenue, Suite 300
Kansas City, MO 64108
816-474-8237

GENERAL CONTRACTOR

CDI Contractors
3000 Cantrell Rd.
Little Rock, AR 72202
501-666-4300

MECHANICAL SUBCONTRACTOR

Comfort Systems USA (Arkansas), Inc.
9924 Landers Rd.
N. Little Rock, AR 72117
501-834-3320

Notes:

CSUSA PROJECT NO.

22-6069

sean@comfortar.com

9924 Landers Rd.
No. Little Rock, AR 72117

Drop-in Anchors Fig. 05-470

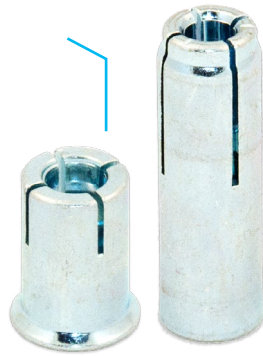

Specifications

Materials:

Zinc Plated Steel

Part Numbers:

05-470-00 3/8"
 05-471-00 1/2"
 05-472-00 3/8", mini

Use With:

05-475-00
 Setting Tool 3/8"
 05-474-00
 Setting Tool 1/2"
 05-476-00
 Setting Tool 3/8", mini

Description

FPPI Drop-In Anchors and Mini Drop-In Anchors are UL listed in accordance with NFPA requirements. Zinc plating provides corrosion resistance. Follow NFPA requirements and installation instructions for proper use.

Installation

STEP 1: Using a masonry bit suitable for the material being drilled, drill an appropriate diameter hole at the correct depth according to the table below.

Anchor Size	Drill Size	Minimum Hole Depth
3/8" Standard	1/2"	1 9/16"
1/2" Standard	5/8"	2"
3/8" Mini	1/2"	3/4"

STEP 2: Insert the anchor into the hole until the edge of the anchor is flush* with the surface of the material the anchor is being installed in. *The Anchor may be installed at a greater depth by drilling the hole to the desired depth and threading the correct size bolt for the size anchor being installed and tapping the anchor into the drilled hole.

STEP 3: After inserting the anchor to the desired depth, insert the correct size setting tool into the anchor and drive the plug into the anchor until the shoulder of the setting tool meets the edge of the anchor. The anchor is now installed and ready to be used.

Note: It is recommended that when used in cinder block, that the anchor be placed between the cells.

Average Pullout Values For 4000psi Concrete

Part Number	Bolt Size	Pullout Value
Standard Drop-In		
05-470-00	3/8"	5,530 lbs
05-471-00	1/2"	8,080 lbs
Mini Drop-In		
05-472-00	3/8"	1,980 lbs



PROJECT INFORMATION	APPROVAL STAMP
Project:	Approved
Address:	Approved as noted
Contractor:	Not approved
Engineer:	Remarks:
Submittal Date:	
Notes 1:	
Notes 2:	

Universal C-type Clamp (Standard Throat)

Fig. 92 (Formerly Afcon Fig. 100)

Material Specifications

Size Range
3/8" and 1/2"

Material
Ductile iron, hardened steel cup point set screw and locknut.

Finish
Plain
Zinc Plated (Hot-Dip Galvanized optional)

Service
Recommended for use under roof installations with bar joist type construction, or for attachment to the top or bottom flange of structural shapes where the vertical hanger rod is required to be offset from the edge of the flange and where the thickness of joist or flange does not exceed 3/4".

Approvals
Complies with Federal Specification A-A-1192A (Type 19 & 23), WW-H-171-E (Type 23), ANSI/MSS SP-69 and MSS SP-58 (Type 19 & 23).
UL, ULC Listed and FM Approved.

How to size
Size of clamp is determined by size of rod to be used.

Installation
Follow recommended set screw torque values per MSS-SP-69.

- Features**
- They may be attached to horizontal flanges of structural members in either the top beam or bottom beam positions.
 - Secured in place by a cup-pointed Set Screw tightened against the flange. A Jam Nut is provided for tightening the Set Screw against the Body Casting.
 - Thru tapping of the body casting permits extended adjustment of the threaded rod.
 - Can be used with Fig 89X retaining clip for seismic applications.

Ordering
Specify rod size, figure number, name of clamp and finish.

Available with oversized tapped rod hole for Hot Dip Galvanized finish.

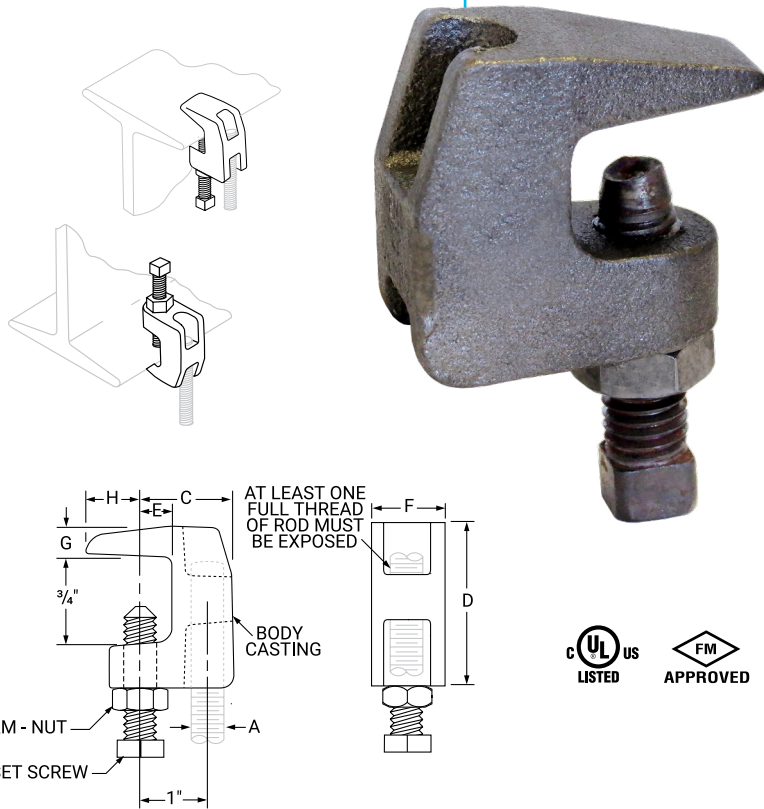

Dimensions (In) - Load (Lbs) - Torque (In-Lbs) - Weight (Lbs)

Rod Size A	Set Screw Size	Torque Value	Max Loads ■		Weight	C	D	E	F	G	H
			Top	Bottom							
In.	In.	In.-Lbs.	Lbs.	Lbs.	Lbs.	In.	In.	In.	In.	In.	In.
3/8	3/8	60	500	250	0.34	1 5/16	1 9/16	9/16	13/16	3/8	1/2
1/2	1/2	125	950	760	0.63	1 3/8	1 13/16	1/2	1 1/16	7/16	23/32

Note:
■ Maximum temperature of 450° F

PROJECT INFORMATION	APPROVAL STAMP
Project:	Approved
Address:	Approved as noted
Contractor:	Not approved
Engineer:	Remarks:
Submittal Date:	
Notes 1:	
Notes 2:	

Wide Throat Top Beam C-Clamp Fig. 94

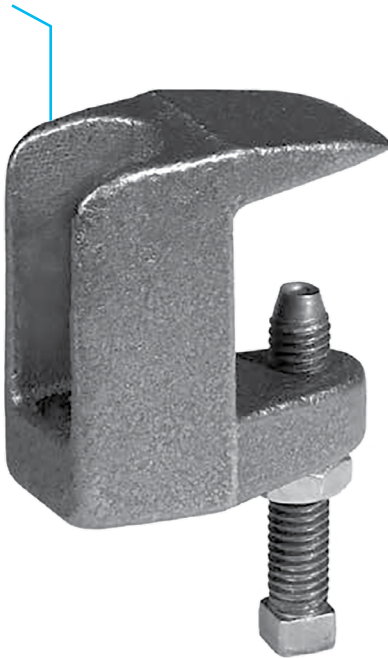

Features:

- Provides clamping to bar joists which are directly under roof installations.
- Provides for vertical hanger rod installed offset from the edge of the beam flange.
- Ductile iron body assures full thread engagement of rod.

Material Specifications

Size Range
5/8" and 3/4"

Material
Ductile iron body, hardened steel cup point set screw and locknut.

Finish
Plain or
Zinc Plated (Hot-Dip Galvanized optional)

Service
Recommended for use under roof installations with bar joist type construction, or for attachment to the top flange of structural shapes where the vertical hanger rod is required to be offset from the edge of the flange and where the thickness of joists or flange does not exceed 1 5/16".

Approvals
Complies with Federal Specification A-A-1192A (Type 19)
WW-H-171-E (Type 19), ANSI/MSS SP-69 and MSS SP-58 (Type 19), UL Listed.

How to size
Size of clamp is determined by size of rod to be used.

Installation
Follow maximum recommended set screw torque values per MSS-SP-69.

Ordering
Specify rod size, figure number, name of clamp and finish.
Available with oversized tapped rod hole for Hot Dip Galvanized finish.



PROJECT INFORMATION	APPROVAL STAMP
Project:	Approved
Address:	Approved as noted
Contractor:	Not approved
Engineer:	Remarks:
Submittal Date:	
Notes 1:	
Notes 2:	

Wide Throat Top Beam C-Clamp Fig. 94

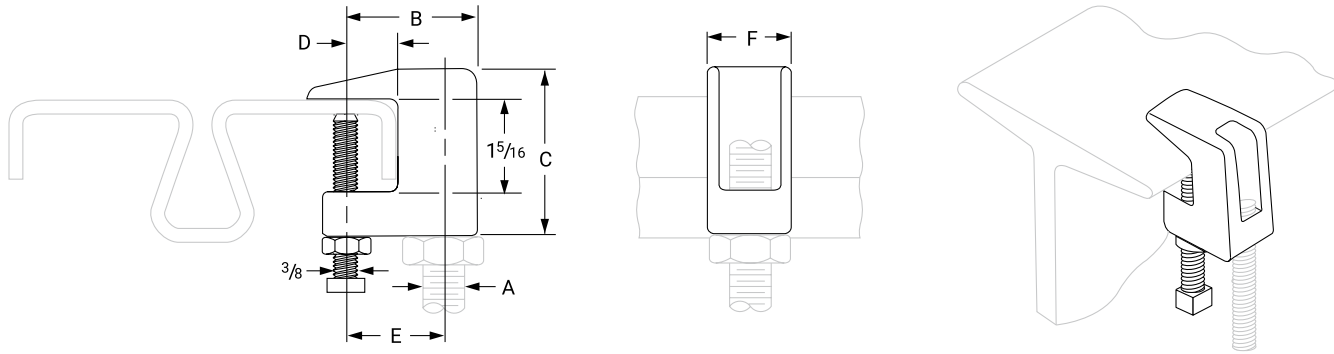

Dimensions (In) • Load (Lbs) • Torque (In-Lbs) • Weight (Lbs)

Rod Size A	Set Screw Size	Torque Value	Max Loads*	Weight	B	C	D	E	F
5/8	3/8	60	1,200	0.66	1 3/4	2 1/4	3/4	1 1/4	1
3/4	3/8	60	1,600	0.83	1 7/8	2 3/8		1 3/8	1 3/16

Note:

* Maximum temperature of 450° F



asc-es.com

Building connections that last™

Adjustable Clevis Hanger Fig. 260 (Formerly Afcon Fig. 371)

Size Range: ½" through 30"

Material: Carbon Steel

Finish: Plain, 8" & Smaller: Zinc Plated (Hot-Dip Galvanized optional), 10" & Larger: Hot-Dip Galvanized with Zinc Plated Bolts & Nuts, or Primed, also available in Plastic or Epoxy Coated.

Service: Recommended for the suspension of stationary pipe lines.

Maximum Temperature: Plain 650° F, Galvanized and Epoxy 450° F

Approvals: Complies with Federal Specification A-A-1192A (Type 1), WW-H-171-E (Type 1), ANSI/MSS SP-69 and MSS SP-58 (Type 1). FM Approved (Sizes ¾" through 8"), UL and ULC Listed (Sizes ½" through 8").

Installation: Hanger load nut above clevis must be tightened securely to assure proper hanger performance.

Adjustment: Vertical adjustment without removing pipe may be made from ¾" through 5/8", varying with the size of clevis. Tighten upper nut after adjustment.

Features:

- Design has yoke on outside of lower U-strap so yoke cannot slide toward center of bolt, thus bending of bolt is minimized.
- Sizes 5" and up have rod and two nuts instead of bolt and nut; thread length on clevis rod is such that the thread locks the nuts in place, and threads are not in shear plane.

Ordering:

Specify pipe size, figure number, name and finish.

Notes:

- Punched forming holes may be present on certain sizes of this clevis hanger. These holes are solely for the purpose of manufacturing, and do not effect the structural integrity or load carrying capacities of these hangers.
- For insulated line options without shields, see Figures 260 ISS and Figure 300. For insulated line options with shields, see Figures 167 and 168. For ductile iron pipe sizes, see Figure 590.
- Fig. 260F (Felt lined) – available for use for suspension of copper (or other material) so as to prevent electrolysis between the dissimilar metals of the hanger and the pipe, tube or conduit.

Caution:

When an oversize clevis is used, a pipe spacer or multispaceer should be placed over clevis bolt to ensure that the lower U-strap will not move in on the bolt.



PROJECT INFORMATION	APPROVAL STAMP
Project:	Approved
Address:	Approved as noted
Contractor:	Not approved
Engineer:	Remarks:
Submittal Date:	
Notes 1:	
Notes 2:	

Adjustable Clevis Hanger (Cont.) Fig. 260 (Formerly Afcon Fig. 371)

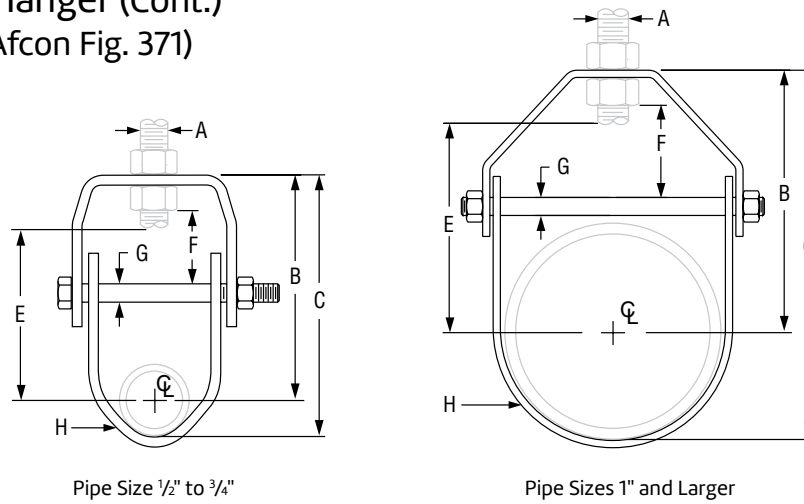

Fig. 260: Dimensions (in) • Loads (lbs) • Weight (lbs)

Pipe Size	Max Load	Span Ft.	Weight	Rod Size A	B	C	Rod Take Out E	Adjust. F	G	H Width Lower			
1/2	610	7*	0.34	3/8	2 ³ / ₁₆	2 ¹¹ / ₁₆	1 ¹ / ₂	5/8	1/4	1			
3/4			0.34		2						1 ⁵ / ₁₆		
1			0.35		2 ⁵ / ₁₆						3	1 ⁵ / ₈	
1 1/4	730	9*	0.40	1/2	2 ³ / ₈	3 ¹³ / ₁₆	2 ¹ / ₈	7/8	3/8	1 1/4			
1 1/2			0.45		2 ¹³ / ₁₆						3 ¹³ / ₁₆	2 ¹ / ₈	1 ¹ / ₈
2			0.50		3 ⁵ / ₁₆						4 ¹ / ₂	2 ⁵ / ₈	1 ⁵ / ₁₆
2 1/2	1,350	11*	0.65	5/8	4 ¹ / ₁₆	5 ¹ / ₂	3 ³ / ₁₆	1 ⁵ / ₈	3/8	1 1/4			
3			0.85		4 ³ / ₄						6 ¹ / ₂	4 ¹ / ₁₆	1 ⁵ / ₈
3 1/2			1.10		5 ¹ / ₁₆						7 ¹ / ₁₆	4 ³ / ₁₆	1 ¹³ / ₁₆
4	1,430	13*	1.51	3/4	5 ⁹ / ₁₆	7 ¹³ / ₁₆	4 ¹ / ₂	1 ¹¹ / ₁₆	3/8	1 3/16			
5			1.70		6 ⁹ / ₁₆						8 ¹⁵ / ₁₆	5 ¹ / ₂	1 ¹⁵ / ₁₆
6			3.10		6 ¹⁵ / ₁₆						10 ¹ / ₄	5 ³ / ₄	1 ¹¹ / ₁₆
8	2,000	16*	4.75	7/8	8 ³ / ₈	12 ¹¹ / ₁₆	7 ³ / ₁₆	2	1/2	1 7/16			
10			8.60		9 ⁷ / ₈						15 ¹ / ₄	8 ⁷ / ₁₆	2 ¹ / ₈
12			11.20		11 ⁹ / ₁₆						17 ¹⁵ / ₁₆	10 ¹ / ₈	2 ¹³ / ₁₆
14	4,200	17*	12.50	1	12 ⁹ / ₁₆	19 ⁹ / ₁₆	10 ¹¹ / ₁₆	2 ¹¹ / ₁₆	3/4	2			
16			19.85		14						22	12	2 ³ / ₄
18			22.25		15 ¹⁵ / ₁₆						24 ¹⁵ / ₁₆	13 ¹⁵ / ₁₆	3 ¹³ / ₁₆
20	4,800	19*	40.33	1 1/4	17 ⁹ / ₁₆	27 ⁹ / ₁₆	15 ³ / ₁₆	3 ⁷ / ₈	1/4	3			
24**			49.83		19 ¹³ / ₁₆						31 ¹³ / ₁₆	17 ⁵ / ₁₆	7 ⁵ / ₈ *
30***			70.18		24 ³ / ₁₆						39 ³ / ₁₆	21 ⁹ / ₁₆	5 ¹ / ₈

"Span" represents the maximum recommended distance between hangers on a continuous and straight run of horizontal standard weight steel pipe filled with water. In all cases, verify that chosen location of hangers does not subject hangers to a load greater than the maximum recommended load shown above.

*Indicates that span represents the maximum span for water filled pipe.

**The 24" pipe size assembly includes a 1 1/4" SCH 40 pipe spacer over the 7/8" threaded rod.

***The 30" pipe size assembly includes a 1 1/4" SCH 40 pipe spacer over the 1 1/4" threaded rod. When assembled, the U-strap sits outside of the yoke.

Channel Fig. AS 200

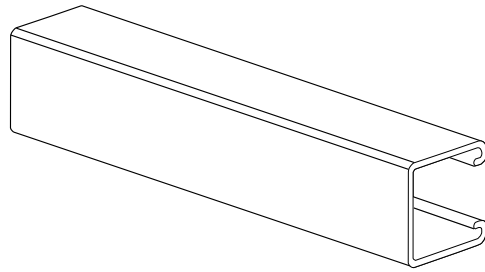

Description

Anvil-Strut channels are manufactured by a series of forming dies, or rolls, which progressively cold work the strip steel into the desired channel configuration. This method produces a cross section of uniform dimensions within a tolerance of plus or minus 0.015", on outside dimensions.

Solid AS 200

PL, GR, PG, SS, ZTC, HG

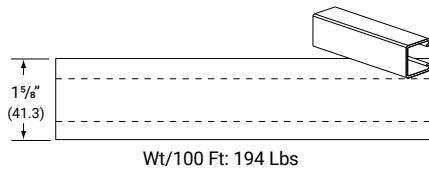

With Elongated Holes AS 200EH

PL, GR, PG, SS, ZTC, HG

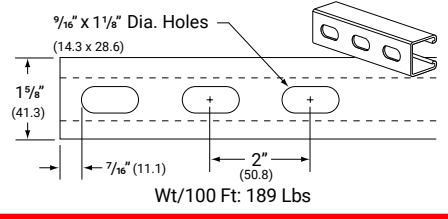

With Knock Out AS 200KO

PL, GR, PG, Other

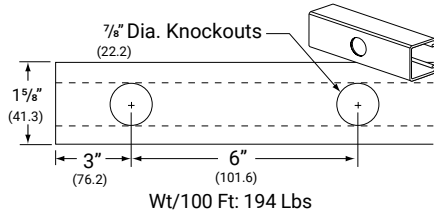

With Holes AS 200H

PL, GR, PG, Other

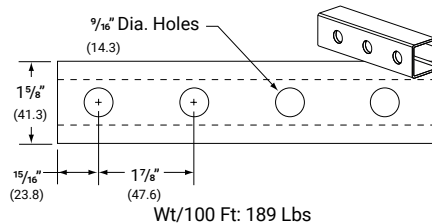

With Long Slots AS 200S

PL, GR, PG, Other

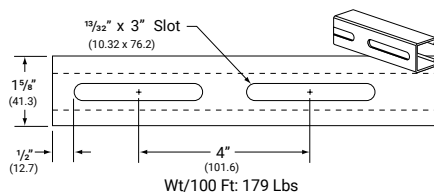

With Holes on 3 Sides AS 200H3

PL, GR, PG, Other

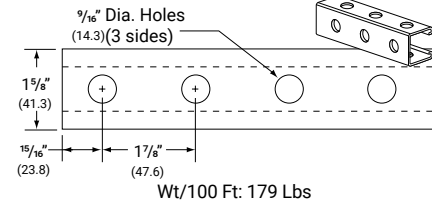

Specifications

Size:

1 5/8" X 1 5/8" (41.3 x 41.3mm)
12 Gauge Channel • wt./100 ft. - 194 lbs.

Materials:

Carbon Steel
Stainless Steel
Aluminum

Finishes

Pre-Galvanized
Hot Dip Galvanized - Post Fabrication
Supr-Green Powder Coated
Zinc Trivalent Chromium
PVC

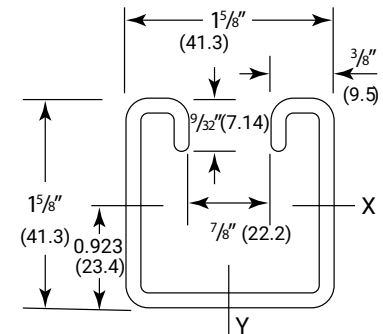

LEGEND:

GR: Powder Coated Supr-Green
EG: Electro-Galvanized
PG: Pre-Galvanized
AL: Aluminum
HG: Hot Dipped Galvanized
PL: Plain
SS: Stainless Steel
ZTC: Zinc Trivalent Chromium Stainless Steel (SS), Zinc Trivalent Chromium (ZTC) and Hot Dipped Galvanized (HG) are specialty finishes. Pricing is located in the Specialty Strut Section of the Anvil-Strut price book.



PROJECT INFORMATION	APPROVAL STAMP
Project:	Approved
Address:	Approved as noted
Contractor:	Not approved
Engineer:	Remarks:
Submittal Date:	
Notes 1:	
Notes 2:	

Channel Fig. AS 200

1⁵/₈" X 1⁵/₈" (41.3 x 41.3mm)
 12 Gauge Channel • wt./100 ft. – 194 lbs
 Stocked in pre-galvanized, plain, powder coated
 Supr-Green, zinc trivalent chromium, and hot dipped
 galvanized, in 10 & 20 ft. lengths. Note: Also available in
 Stainless Steel 304 & 316 Alloys. Other materials, finishes
 & lengths are available upon request.

Properties of Section

Catalog Number	Wt./Ft.		Area of Selection		X-X Axis						Y-Y Axis					
	Lbs.	Kg.	Sq. In.	Sq. CM	I in ⁴	I cm ⁴	S in ³	S cm ³	r in	r cm	I in ⁴	I cm ⁴	S in ³	S cm ³	r in	r cm
AS 200	1.94	2.9	0.552	3.561	0.188	7.825	0.208	3.409	0.584	1.483	0.236	9.823	0.290	4.752	0.654	1.661

I = Moment of Inertia S = Section Modulus r = Radius of Gyration

Beam and Column Loads

Span or Unbraced Height	Static Beam Load (X-X Axis)							Column Loading Data			
	Max Allowable Uniform Load	Deflection at Uniform Load	Uniform Load at Deflection				Max. Allowable Load at Slot Face	Max. Column Load Applied at C.G.			
			Span/180 Deflection	Span/240 Deflection	Span/360 Deflection	Weight of Channel		k=.65	k=.80	k=1.0	k=1.2
In	Lbs	In	Lbs	Lbs	Lbs	Lbs	Lbs	Lbs	Lbs	Lbs	Lbs
12	3,480	0.01	3,480	3,480	3,480	1.9	3,850	12,240	11,940	11,480	10,960
18	2,320	0.03	2,320	2,320	2,320	2.9	3,710	11,540	10,960	10,130	9,290
24	1,740	0.06	1,740	1,740	1,740	3.9	3,530	10,690	9,850	8,740	7,710
30	1,390	0.09	1,390	1,390	1,310	4.9	3,330	9,780	8,740	7,470	6,380
36	1,160	0.13	1,160	1,160	910	5.8	3,120	8,880	7,710	6,380	5,310
42	990	0.17	990	990	670	6.8	2,910	8,020	6,800	5,470	4,430
48	870	0.23	870	770	510	7.8	2,710	7,240	6,000	4,690	3,810
60	700	0.35	660	490	330	9.7	2,340	5,910	4,690	3,630	2,960
72	580	0.51	460	340	230	11.6	2,040	4,840	3,810	2,960	2,400
84	500	0.69	340	250	170	13.6	1,800	4,040	3,200	2,480	1,980
96	430	0.90	260	190	130	15.5	1,600	3,480	2,750	2,110	1,670
108	390	1.14	200	150	100	17.5	1,440	3,050	2,400	1,820	**
120	350	1.41	160	120	80	19.4	1,290	2,700	2,110	**	**
144	290	2.03	110	90	60	23.3	1,060	2,180	1,670	**	**
168	250	2.77	80	60	40	27.2	**	1,790	**	**	**
180	230	3.18	70	50	40	29.1	**	**	**	**	**
192	220	3.61	60	50	NR	31.6	**	**	**	**	**
216	190	4.57	50	40	NR	34.9	**	**	**	**	**
240	170	5.65	40	NR	NR	38.8	**	**	**	**	**

Bearing Load may limit load
 ** Not recommended - KL/r exceeds 200

- Notes
- The beam capacities shown above include the weight of the strut beam. The beam weight must be subtracted from these capacities to arrive at the net beam capacity.
 - Allowable beam loads are based on a uniformly loaded, simply supported beam. For capacities of a beam loaded at midspan at a single point, multiply the beam capacity by 50% and deflection by 80%.
 - The above chart shows beam capacities for strut without holes. For strut with holes, multiply by the following:
 EH by 88%, S by 90%,
 H (3/16 holes) by 88%, KO by 82%.
 - Refer to the Anvil-Strut Catalog for reduction factors for unbraced lengths.



Channel Fig. AS 200

Beam and Column Loads – Metric

Span or Unbraced Height	Static Beam Load (X-X Axis)							Column Loading Data			
	Max Allowable Uniform Load	Deflection at Uniform Load	Uniform Load at Deflection				Max. Allowable Load at Slot Face	Max. Column Load Applied at C.G.			
			Span/180 Deflection	Span/240 Deflection	Span/360 Deflection	Weight of Channel		k=.65	k=.80	k=1.0	k=1.2
mm	Kn	mm	Kn	Kn	Kn	Kg	Kn	Kn	Kn	Kn	Kn
305	15.5	0.3	15.5	15.5	15.5	0.9	17.1	54.4	53.1	51.1	48.8
457	10.3	0.8	10.3	10.3	10.3	1.3	16.5	51.3	48.8	45.1	41.3
610	7.7	1.5	7.7	7.7	7.7	1.8	15.7	47.6	43.8	38.9	34.3
762	6.2	2.3	6.2	6.2	5.8	2.2	14.8	43.5	38.9	33.2	28.4
914	5.2	3.3	5.2	5.2	4.0	2.6	13.9	39.5	34.3	28.4	23.6
1,067	4.4	4.3	4.4	4.4	3.0	3.1	12.9	35.7	30.2	24.3	19.7
1,219	3.9	5.8	3.9	3.4	2.3	3.5	12.1	32.2	26.7	20.9	16.9
1,524	3.1	8.9	2.9	2.2	1.5	4.4	10.4	26.3	20.9	16.1	13.2
1,829	2.6	13.0	2.0	1.5	1.0	5.3	9.1	21.5	16.9	13.2	10.7
2,134	2.2	17.5	1.5	1.1	0.8	6.2	8.0	18.0	14.2	11.0	8.8
2,438	1.9	22.9	1.2	0.8	0.6	7.0	7.1	15.5	12.2	9.4	7.4
2,743	1.7	29.0	0.9	0.7	0.4	7.9	6.4	13.6	10.7	8.1	**
3,048	1.6	35.8	0.7	0.5	0.4	8.8	5.7	12.0	9.4	**	**
3,658	1.3	51.6	0.5	0.4	0.3	10.6	4.7	9.7	7.4	**	**
4,267	1.1	70.4	0.4	0.3	0.2	12.3	**	8.0	**	**	**
4,572	1.0	80.8	0.3	0.2	0.2	13.2	**	**	**	**	**
4,877	1.0	91.7	0.3	0.2	**	14.1	**	**	**	**	**
5,486	0.8	116.1	0.2	0.2	**	15.8	**	**	**	**	**
6,096	0.8	143.5	0.2	**	**	17.6	**	**	**	**	**

Channel Fig. AS 200

Materials

Carbon Steel: Channels are formed from high-quality, structural grade carbon steel which has been manufactured in accordance with ASTM A-1011-04- SS Grade 33 (hot rolled), or ASTM 366 (cold rolled), with mechanical properties of 33 ksi minimum yield and 52 ksi minimum tensile strength. The precision roll-forming process by which the channels are formed “cold works” the steel, thereby increasing its mechanical properties.

Stainless Steel: Channels are formed from chromium-nickel stainless steel sheet manufactured in accordance with ASTM A-240 specification, offered in both AISI Type 304 and 316 material to provide protection in varying corrosive conditions.

Aluminum: Extruded aluminum channel is produced from 6063-T6 alloy, and fittings are produced from 5052-H32 alloy, both in accordance with ASTM B-221 specifications. Aluminum is suitable for use in various corrosive environments.

Finishes

Pre-Galvanized: Hot dip, mill galvanized coating produced through a process of continuously passing the steel through a bath of molten zinc. This process is performed in accordance with ASTM A-653. The thickness of the zinc coating conforms with ASTM G-90 which represents a coating thickness of .90 ounces of zinc per square foot. This coating is applied to the steel master coils prior to slitting and fabrication.

Hot Dip Galvanized - Post Fabrication: The finished channel is completely immersed in a bath of molten zinc, resulting in the complete coating of all surfaces of the product, including edges and welds. Strut channels that are hot dip galvanized, have a total coating weight of 3.0 ounces of zinc per square foot in accordance with ASTM A-123 specification. This coating provides superior results in applications calling for prolonged outdoor exposure.

Supr-Green Powder Coating: Strut channels are coated after fabrication with polyester powder finish. This coating is applied using an electrostatic spray process, beginning with cleaning and phosphating, through a bonderite pretreatment process, and ending with oven curing. The resulting finish provides a high quality appearance and durability. Powder Coating is in accordance with ASTM B-117 (standard practice for operating salt spray (fog) apparatus) to 500 hours with less than 1/8” scribe creep.

Zinc Trivalent Chromium: The finished channel undergoes a multi-step process consisting of electrogalvanizing, in accordance with ASTM B-633-85, followed by an application of zinc trivalent chromium, which provides the distinctive gold coloration of the finish. All surfaces are coated because the process is performed after fabrication.

PVC: A corrosive resistant PVC (polyvinyl chloride) coating is applied over the completed strut channel. The coating process consists of surface pretreatment, followed by preheating of the part, which is then passed through a fluidized bed of vinyl plastic powder. The powder melts onto the heated channel forming a smooth coating which undergoes a final heat curing.

Cushion Clamp Assembly Figs. AS 0040D through AS 106P



Specifications

Materials:

Clamp: 1008-1018 Carbon Steel
Cushion: High Strength TPE
Locknut: Nylon Insert

Service Temperature:

-65°F to 275°F

Approvals:

UL 2043 Fire Test for Heat and Visible Smoke Release
25/50 Flame Spread/Smoke Development Index

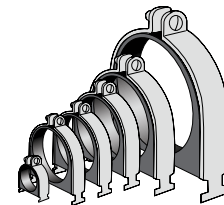

Description

Anvil-Strut Pipe Clamps are all manufactured to fit into the standard openings of 1⁵/₈" channel to support runs of piping where desired, to secure the pipe in place.

AS 0040D Thru AS 106P EG, 304SS, 316SS, ZTC

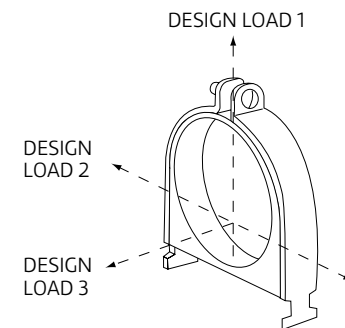
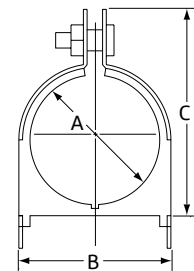

LEGEND:

GR: Powder Coated Supr-Green **EG:** Electro-Galvanized **PG:** Pre-Galvanized **AL:** Aluminum
HG: Hot Dipped Galvanized **PL:** Plain SS: Stainless Steel
ZTC: Zinc Trivalent Chromium Stainless Steel (**SS**), Zinc Trivalent Chromium (**ZTC**) and Hot Dipped Galvanized (**HG**) are specialty finishes. Pricing is located in the Specialty Strut Section of the Anvil-Strut price book.



PROJECT INFORMATION	APPROVAL STAMP
Project:	Approved
Address:	Approved as noted
Contractor:	Not approved
Engineer:	Remarks:
Submittal Date:	
Notes 1:	
Notes 2:	

Cushion Clamp Assembly Figs. AS 0040D through AS 106P

Tube Series

Part Number	O.D. Size	A	B	C	Std Pkg	Wt/100 pcs
AS 0040D	1/4"	0.25	0.62	0.98	25	10
AS 0060DN	3/8"	0.37	0.82	1.13	25	11
AS 0080DN	1/2"	0.50	0.94	1.34	25	13
AS 0100DN	5/8"	0.62	1.06	1.54	25	14
AS 0120DN	3/4"	0.75	1.20	1.68	25	14
AS 0140DN	7/8"	0.87	1.31	1.82	25	15
AS 0160D	1"	1.00	1.44	1.95	25	17
AS 0180DN	1 1/8"	1.12	1.57	2.08	20	18
AS 0200D	1 1/4"	1.25	1.70	2.21	20	18
AS 0220DN	1 3/8"	1.37	1.82	2.34	20	20
AS 0240D	1 1/2"	1.50	1.95	2.47	20	33
AS 0260DN	1 5/8"	1.62	2.07	2.60	20	35
AS 0280D	1 3/4"	1.75	2.20	2.73	20	37
AS 0320D	2"	2.00	2.45	3.04	10	41
AS 0340D	2 1/8"	2.12	2.57	3.23	10	46
AS 0400D	2 1/2"	2.50	2.94	3.79	10	49
AS 0420D	2 5/8"	2.62	3.07	3.92	5	51
AS 0480D	3"	3.00	3.57	4.42	5	57
AS 0500D	3 1/8"	3.12	3.57	4.42	5	60
AS 0580D	3 5/8"	3.62	4.20	5.11	5	70
AS 0660D	4 1/8"	4.12	4.57	5.54	5	94
AS 0820D	5 1/8"	5.12	5.57	6.54	5	125
AS 0980D	6 1/8"	6.12	6.57	7.54	5	130

Std Pkg & Wt/100 pcs: See charts above.

Specifications

Materials:

Clamp: 1008-1018 Carbon Steel
Cushion: High Strength TPE
Locknut: Nylon Insert

Service Temperature:

-65°F to 275°F

Approvals:

UL 2043 Fire Test for Heat and Visible Smoke Release
25/50 Flame Spread/Smoke Development Index

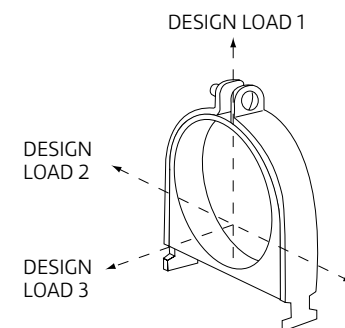
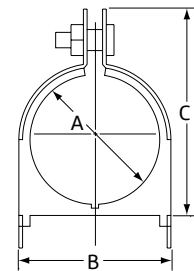
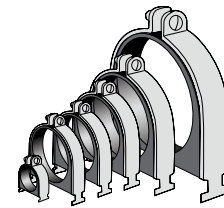

Cushion Clamp Assembly Figs. AS 0040D through AS 106P

Tube Series

Copper & Steel Tube O.D. Size	Design Load 1 (lbs)	Design Load 2 (lbs)	Design Load 3 (lbs)
1/4"	400	50	50
3/8"	400	50	50
1/2"	400	50	50
5/8"	400	50	50
3/4"	600	75	75
7/8"	600	75	75
1"	600	75	75
1 1/8"	600	75	75
1 1/4"	600	75	75
1 3/8"	600	75	75
1 1/2"	600	75	75
1 5/8"	600	75	75
1 3/4"	800	125	125
1 7/8"	800	125	125
2"	800	125	125
2 1/8"	800	125	125
2 1/4"	800	125	125
2 3/8"	800	125	125
2 1/2"	800	125	125
2 5/8"	800	125	125
3"	800	125	125
3 1/8"	800	125	125
3 5/8"	1000	200	150
4 1/8"	1000	200	150
6 1/8"	1000	200	150

Std Pkg & Wt/100 pcs: See charts above.

Specifications

Materials:

Clamp: 1008-1018 Carbon Steel
Cushion: High Strength TPE
Locknut: Nylon Insert

Service Temperature:

-65°F to 275°F

Approvals:

UL 2043 Fire Test for Heat and Visible Smoke Release
25/50 Flame Spread/Smoke Development Index

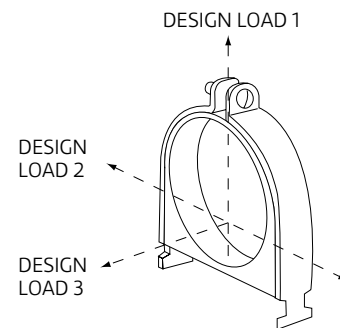
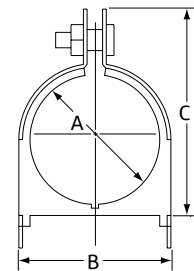
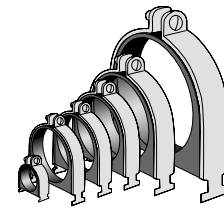

Cushion Clamp Assembly Figs. AS 004OD through AS 106P

Pipe Series

Part Number	O.D. Size	A	B	C	Std Pkg	Wt/100 pcs
AS 009P	1/4" Pipe	0.54	0.98	1.34	25	13
AS 011P	3/8" Pipe	0.67	1.13	1.54	25	14
AS 014P	1/2" Pipe	0.84	1.29	1.82	25	15
AS 017P	3/4" Pipe	1.05	1.50	2.08	20	17
AS 021P	1" Pipe	1.31	1.76	2.34	20	19
AS 027P	1 1/4" Pipe	1.66	2.17	2.73	20	35
AS 030ODP	1 1/2" Pipe	1.90	2.35	2.86	20	39
AS 038ODP	2" Pipe	2.37	2.82	3.67	10	47
AS 046ODP	2 1/2" Pipe	2.87	3.32	4.17	5	55
AS 056ODP	3" Pipe	3.50	3.95	4.79	5	55
AS 064ODP	3 1/2" Pipe	4.00	4.45	5.42	5	88
AS 072ODP	4" Pipe	4.50	4.95	5.92	5	110
AS 089P	5" Pipe	5.56	6.01	6.92	5	130
AS 106P	6" Pipe	6.62	7.07	8.23	5	140

Pipe Series

Pipe Sizes (Nominal)	Design Load 1 (lbs)	Design Load 2 (lbs)	Design Load 3 (lbs)
1/4"	400	50	50
3/8"	600	75	75
1/2"	600	75	75
3/4"	600	75	75
1"	600	75	75
1 1/4"	800	125	125
1 1/2"	800	125	125
2"	800	125	125
2 1/2"	800	125	125
3"	1000	200	150
3 1/2"	1000	200	150
4"	1000	200	150
5"	1000	200	150
6"	1000	200	150

Std Pkg & Wt/100 pcs: See charts above.

Specifications

Materials:

Clamp: 1008-1018 Carbon Steel
Cushion: High Strength TPE
Locknut: Nylon Insert

Service Temperature:

-65°F to 275°F

Approvals:

UL 2043 Fire Test for Heat and Visible Smoke Release
25/50 Flame Spread/Smoke Development Index

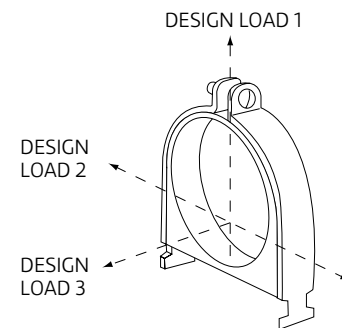
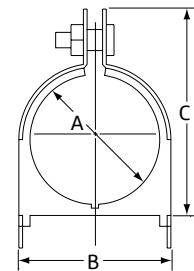
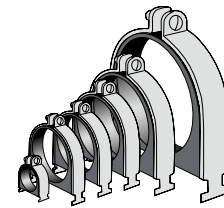

Continuous Threaded Rod Fig. 146 (Formerly Afcon Fig. 650)

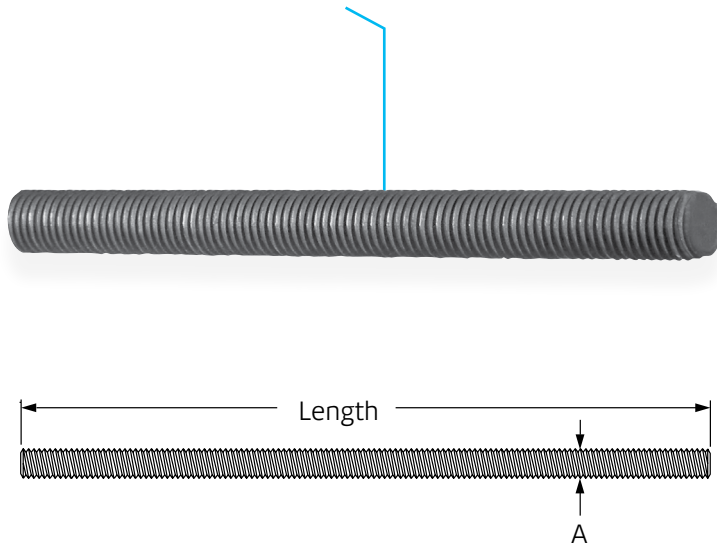

Size Range: ¼" through 1½" stocked in six, ten, and twelve foot lengths. Other even foot lengths can be furnished to order.

Material: Carbon steel or Stainless Steel Gr 304

Threads: National Coarse (USS), rod threaded complete length.

Finish: Plain or Zinc Plated (Hot-Dip Galvanized optional)

Maximum Temperature: Zinc Plated 450°F, Stainless Steel 650°F

Approvals: Complies with MSS SP-58.

Ordering: Specify rod diameter and length, figure number, name and finish.

Note: The acceptability of galvanized coatings at temperatures above 450°F is at the discretion of the end user.

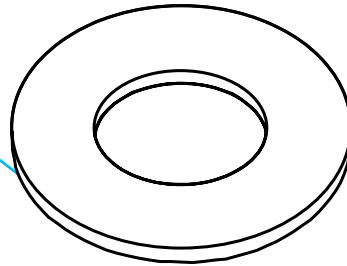

Fig. 146: Dimensions (in) • Loads (lbs) • Weight (lbs)

Rod Size A	Threads per Inch	Max Load	Weight per Ft.
		650° F	
¼	20	240	0.12
⅜	16	730	0.30
½	13	1,350	0.53
⅝	11	2,160	0.84
¾	10	3,230	1.20
⅞	9	4,480	1.70
1	8	5,900	2.30
1¼	7	9,500	3.60
1½	6	13,800	5.10

PROJECT INFORMATION	APPROVAL STAMP
Project:	Approved
Address:	Approved as noted
Contractor:	Not approved
Engineer:	Remarks:
Submittal Date:	
Notes 1:	
Notes 2:	

Flat Washer
Figs. AS 209, AS 3500,
AS 211, AS 83, AS 209,
AS 6108, AS 230



Description

Anvil-Strut Hardware, when used in conjunction with Anvil-Strut Channel and Nuts, provides a superior grip between channels and fittings.

Seismic Rod Stiffener

AS 3500 EG, ZTC

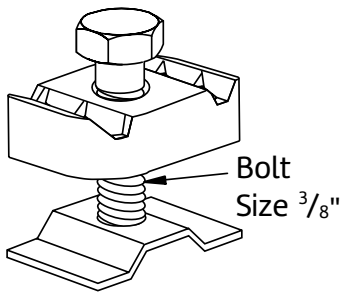

Size	Wt./100 Pcs.
3/8" - 5/8"	16

Std Pkg: 25 - Wt/100 pcs: See chart above.

Lock Washer

AS 211 EG

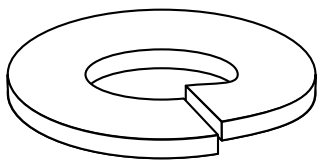

Size	Wt./100 Pcs.
1/4"	0.3
3/8"	0.7
1/2"	1.5

Std Pkg: 100 - Wt/100 pcs: See chart above.

LEGEND:

GR: Powder Coated Supr-Green **EG:** Electro-Galvanized **PG:** Pre-Galvanized **AL:** Aluminum
HG: Hot Dipped Galvanized **PL:** Plain **SS:** Stainless Steel
ZTC: Zinc Trivalent Chromium Stainless Steel (**SS**), Zinc Trivalent Chromium (**ZTC**) and Hot Dipped Galvanized (**HG**) are specialty finishes. Pricing is located in the Specialty Strut Section of the Anvil-Strut price book.



PROJECT INFORMATION	APPROVAL STAMP
Project:	Approved
Address:	Approved as noted
Contractor:	Not approved
Engineer:	Remarks:
Submittal Date:	
Notes 1:	
Notes 2:	

Flat Washer

Figs. AS 209, AS 3500, AS 211, AS 83, AS 209, AS 6108, AS 230

Hexagon Nut

AS 83 EG

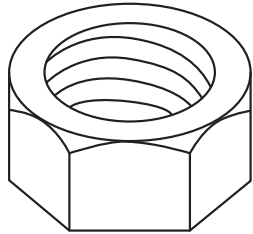

Size	Std. Pkg.	Wt./100 Pcs.
1/4"	500	0.6
3/8"	500	1.6
1/2"	100	4.8
5/8"	50	7.0
3/4"	50	12.0

Std Pkg & Wt/100 pcs: See chart above.

Flat Washer

AS 209 EG

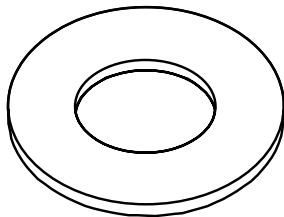

Size	Std. Pkg.	Wt./100 Pcs.
1/4"	200	0.7
3/8"	100	1.5
1/2"	100	3.5
5/8"	100	8.0
3/4"	100	11.0

Std Pkg & Wt/100 pcs: See chart above.

Square Nut

AS 6108 EG

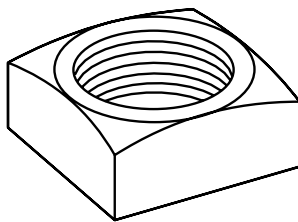

Size	Std. Pkg.	Wt./100 Pcs.
1/4"	100	0.9
5/16"	100	1.6
3/8"	100	2.7
1/2"	100	5.8

Std Pkg & Wt/100 pcs: See chart above.

Square Nut

AS 230 EG

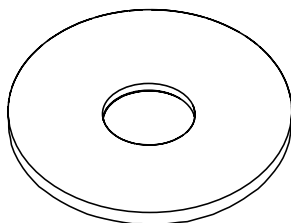

Size	Std. Pkg.	Wt./100 Pcs.
1/4"	100	3.3
3/8"	100	3.0
1/2"	100	2.8

Std Pkg & Wt/100 pcs: See chart above.

LEGEND:

GR: Powder Coated Supr-Green **EG:** Electro-Galvanized **PG:** Pre-Galvanized **AL:** Aluminum
HG: Hot Dipped Galvanized **PL:** Plain **SS:** Stainless Steel
ZTC: Zinc Trivalent Chromium Stainless Steel (**SS**), Zinc Trivalent Chromium (**ZTC**) and Hot Dipped Galvanized (**HG**) are specialty finishes. Pricing is located in the Specialty Strut Section of the Anvil-Strut price book.