

Quality People. Building Solutions.

Comfort Systems USA (Arkansas), Inc.
P.O. Box 16620
Little Rock, AR 72231
Phone 501-834-3320
Fax 501-834-5416

Date: 11/20/2024

Return Request: 11/30/2024

Project: UAMS (CAMID)

Supplier: Harrison Energy

Manufacturer: Apex

Submittal: Containment Filter Housing Assemblies

Submittal Number: 23 40 00-01

Drawing # and Installation: Mechanical Drawings

ARCHITECT

Clark Kenersen
2020 Baltimore Avenue, Suite 300
Kansas City, MO 64108
816-474-8237

ENGINEER

Clark Kenersen
2020 Baltimore Avenue, Suite 300
Kansas City, MO 64108
816-474-8237

GENERAL CONTRACTOR

CDI Contractirs
3000 Cantrell Rd.
Little Rock, AR 72202
501-666-4300

MECHANICAL SUBCONTRACTOR

Comfort Systems USA (Arkansas), Inc.
9924 Landers Rd.
N. Little Rock, AR 72117
501-834-3320

Notes:

CSUSA PROJECT NO.

22-6069

sean@comfortar.com

9924 Landers Rd.
No. Little Rock, AR 72117



Submittal

Prepared For:
Clark & Enerson

Date:
November 1, 2024

Sold To:
Comfort Systems USA

Job Name:
UAMS CAMID

Harrison Energy Partners is pleased to provide the enclosed submittal for your review and approval.

Qty.	Product Summary
1	HEPA Filter Housing

Josh Robinson | Sales Engineer
Harrison Energy Partners
1501 Westpark Drive, Suite 9
Little Rock, AR 72204-2457
Ph. 501-539-0633

The attached information describes the equipment we propose to furnish for this project, and is submitted for your approval.

APEX Filtration Submittal Schedule

Date:10-7-24

Prepared By Russell Black

Schedule				Filters Model / Size	Housing Model/Type	Bank Arrangement	Performance	Resistance Operating	
Item	System	CFM	Qty	SIZE	TYPE		Arrest. / Merv	Initial	Final
1	Camfil Bag-In/Bag-Out Filter Housing System (HFH-1)	4,000	1	N/A	N/A	2 High X 2 Wide Upstream Damper, CF-2X2-BTD-20-M-SS, Square Bubble Tight with Manual Actuator	N/A	N/A	N/A
2	"	4,000	1	(4) Camfil 30/30, 24x24x2	CF-2X2-200-1PB-SS Pre-filter Housing	2 High X 2 Wide	8	~0.14 wg	
3	"	4,000	1	N/A	N/A	2 High X 2 Wide Upstream Test Section, CF-2X2-TSU-14-SS			
4	"	4,000	1	(4) Camfil Absolute Filters, Model 12XH-24Z24Z12-FD-3-C-A/00	CF-2X2-012P-1FB-SS HEPA Housing, Gel Seal	2 High X 2 Wide	99.99% @ 0.3 micron	~0.68 wg	
5	"	4,000	1	N/A	N/A	2 High X 2 Wide Safescan Scan Housing, CF-2X2-SAFESCAN-M-SS, Manual Scan			
6	"	4,000	1	N/A	N/A	2 High X 2 Wide Downstream Damper, CF-2X2-BTD-20-M-SS, Square Bubble Tight with Manual Actuator	N/A	N/A	N/A

Job Name: UAMS - CAMID

Location: Little Rock, Arkansas

Architect: _____

Engineer: Clark & Enersen

Contractor: _____

Gages: (2) Dwyer Magnehelic Differential Pressure Gages, Pre-filter Range 0-1"wg, Final Filter Range 0-3"wg

Spare Filters: None

Bags: (2) Prefilter Bags, 64CX72-3G w/16" Clear, (2) Final Filter Bags, 86CX96-3G w/16" Clear

Security Straps: (2) Pre-filter, 80", (2) Final Filter, 100"

Remarks: Upstream and Downstream transition with 34" bolt flange, Housing Weather Cover Welded On. Lifting Lugs, Swivel Door Latches, and Removable Locking Trays.

APEX Filtration

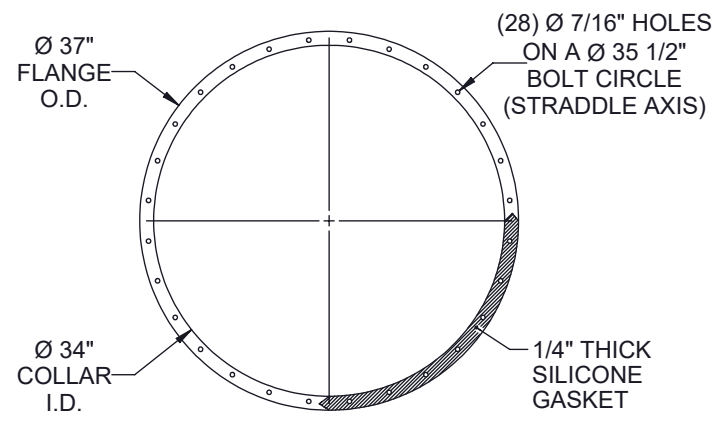
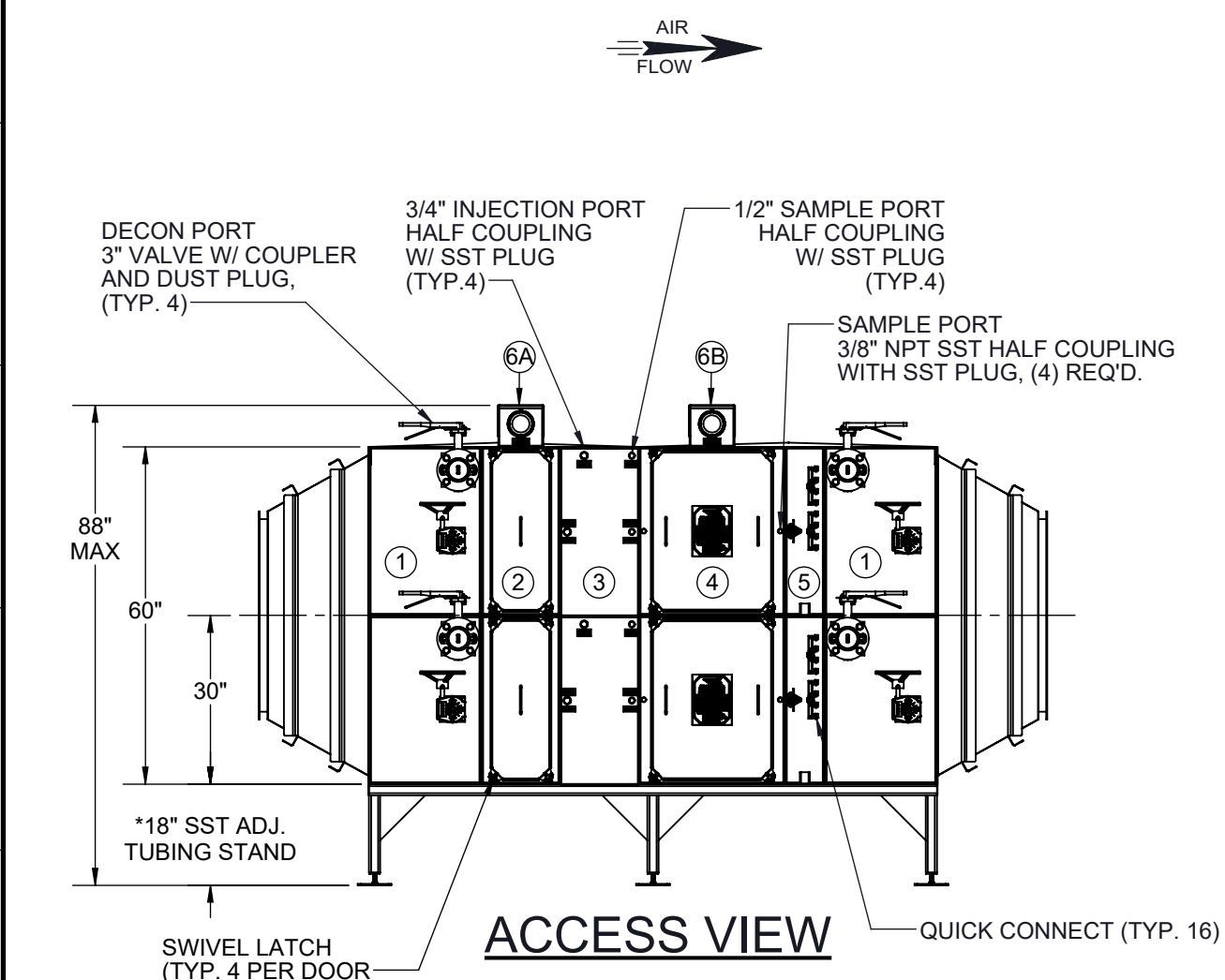
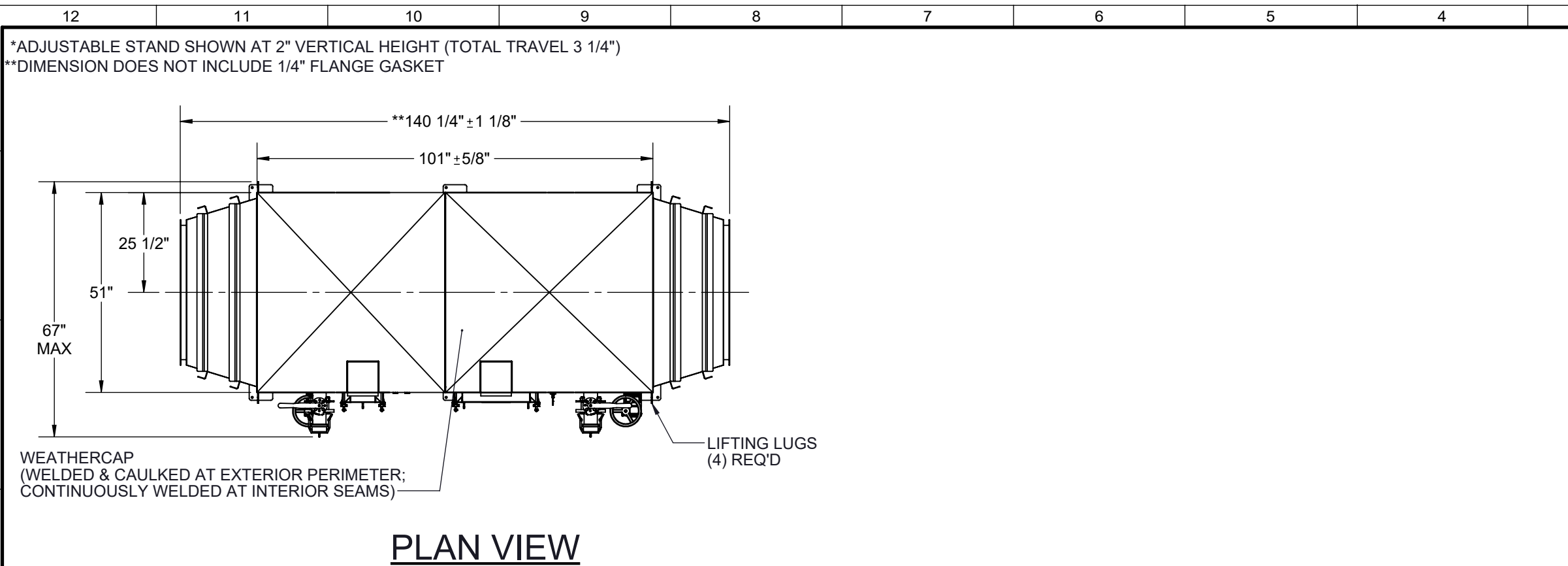

ITEM NO.	SYSTEM CONFIGURATION	QTY.
1	DAMPER	
-	MODEL NO. CF-2X2-BTD-20-M-SS	2
2	PREFILTER HOUSING	
-	MODEL NO. CF-2X2-200-1PB-SS	1
-	FILTER SIZE 24"X24"X2" (NOM.)	4
-	BAG SIZE 64CX72/3G	2
-	STRAP 80"	2
3	UPSTREAM TEST SECTION	
-	MODEL NO. CF-2X2-TSU14-SS	1
4	HEPA HOUSING	
-	MODEL NO. CF-2X2-012P-1FB-SS	1
-	FILTER SIZE 24"X24"X11-1/2"	4
-	BAG SIZE 86CX96/3G	2
-	STRAP 100"	2
5	SCAN HOUSING	
-	MODEL NO. CF-2X2-SAFESCAN-M-SS	1
6	GAGE INFORMATION	
-	MANUFACTURER DWYER,MAGNEHELIC	N/A
A	PREFILTER 2001 0-1" W.G.	1
B	HEPA 2003 0-3" W.G.	1
*	TUBING SST	N/A
-	FITTINGS SST	N/A
-	APPLICATION OUTDOOR	N/A
*	GAGE GUARDIANS REQUIRED	4

*TUBING RUNS & GAGE GUARDIANS NOT SHOWN

PROJECT: CENTER FOR ANIMAL MODELS OF INFECTION

APPROVAL PRINT

APPROVED APPROVED AS NOTED
 REVISE AND RESUBMIT
 SIGNATURE: _____
 DATE: _____

CUSTOMER: AIR FILTER SYSTEMS INC.
 CUSTOMER LOCATION: _____
 CUSTOMER PO NO.: _____
 CAMFIL ORDER NO.: Q241881
 CAMFIL PART NO.: TBD

UNLESS OTHERWISE SPECIFIED, TOLERANCES ARE:
 FRACTION: $\pm 1/8$ "
 DECIMAL: ± 0.125 "

camfil WASHINGTON NORTH CAROLINA www.camfil.com

CAMFIL BAG-IN/BAG-OUT HOUSING
 CF-2X2-BTD-20-M-200-1PB-TSU14-012P-1FB-SAFESCAN-M-BTD-20-M-SS

DRAWN BY: JL DATE: 10/4/2024
 APPR. BY: JRR DATE: 10/4/2024

SCALE: 1:32

DWG SIZE	DRAWING NO.:	SHEET	OF	REV.
B	CB24-0222	1	2	0

QL-3

REV.	DRAWN BY	DESCRIPTION:	APPR. BY

THE INFORMATION CONTAINED ON THIS DRAWING IS PROPRIETARY TO CAMFIL AND MAY NOT BE REPRODUCED NOR TRANSMITTED TO OTHER PARTIES WITHOUT THE CONSENT OF CAMFIL.

SYSTEM TAG AND FILTER SCHEDULE

SYSTEM TAG	SYSTEM ACCESS	AIRFLOW (CFM)	PREFILTER			HEPA FILTER			H.I.D. NUMBER FIRST STAGE	H.I.D. NUMBER SECOND STAGE	HEGA FILTER		TOTAL SYSTEM ΔP	
			MODEL	ΔP CLEAN (W.G.)	ΔP DIRTY (W.G.)	MODEL	ΔP CLEAN (W.G.)	ΔP DIRTY (W.G.)			MODEL	ΔP CLEAN (W.G.)	CLEAN (W.G.)	DIRTY (W.G.)
TBD	TBD	<<8000>>	30/30 24X24X2 MERV 8	0.31"	1.00"	12XH-24Z24Z12-FD-3-C-A-00-A/00	1.65"	3.30"	N/A	N/A	N/A	N/A	2.56"	5.13"

GENERAL HOUSING INFORMATION

HOUSING ACCESS	*SEE CUSTOMER ACTION BLOCK
SYSTEM QUANTITY	1
FILTER ACCESS CLEARANCE	4 FEET REQUIRED
BAGS AND STRAPS SUPPLIED	INITIAL
DESIGN TEMPERATURE	130° F
HOUSING MATERIAL	304/304L
GASKET MATERIAL	SILICONE
SYSTEM FLOW RATE	<<8000>> CFM
DOOR LATCH TYPE	SWIVEL
INSULATION	N/A
SYSTEM WEIGHT(W/O FILTER)	2530 LBS
INITIAL FILTER	YES
SPARE FILTER	N/A
TESTING	
TESTING METHOD	ASME N510-1995
OVERALL PRESSURE	+15" W.G.
OVERALL DURATION	5 MINUTES
SEAL SURFACE PRESSURE	+10" W.G.
SEAL SURFACE DURATION	5 MINUTES
LEAK RATE	0.0005 CFM PER CUBIC FOOT OF HOUSING VOLUME
STRUCTURAL CAPABILITY	N/A
DAMPER INFORMATION	
ACTUATOR TYPE	MANUAL
ACTUATOR MODEL NO.	DT-3
FAIL POSITION	N/A
VOLTAGE	N/A
DAMPER TESTING	
TESTING METHOD	ASME N510-1995
OVERALL PRESSURE	+15" W.G.
OVERALL DURATION	5 MINUTES
DAMPER BLADE PRESSURE	+10" W.G.
OVERALL LEAK RATE	0.0005 CFM PER CUBIC FOOT OF HOUSING VOLUME

<<AIRFLOW NOT PROVIDED; AIRFLOW BASED ON RATED AIRFLOW CAPACITY OF FILTER>>

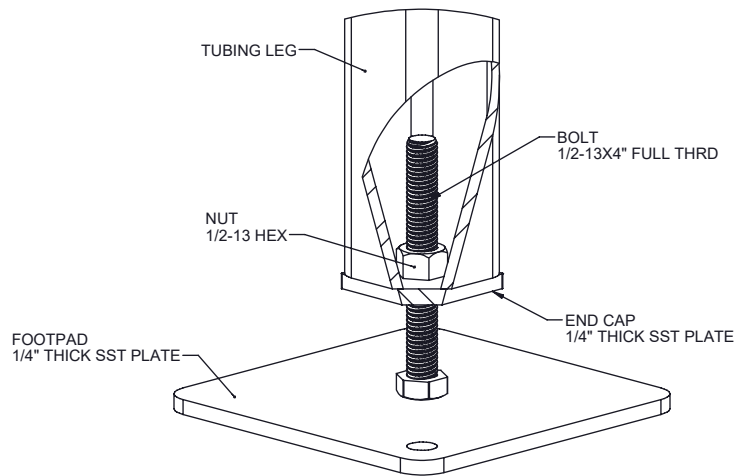
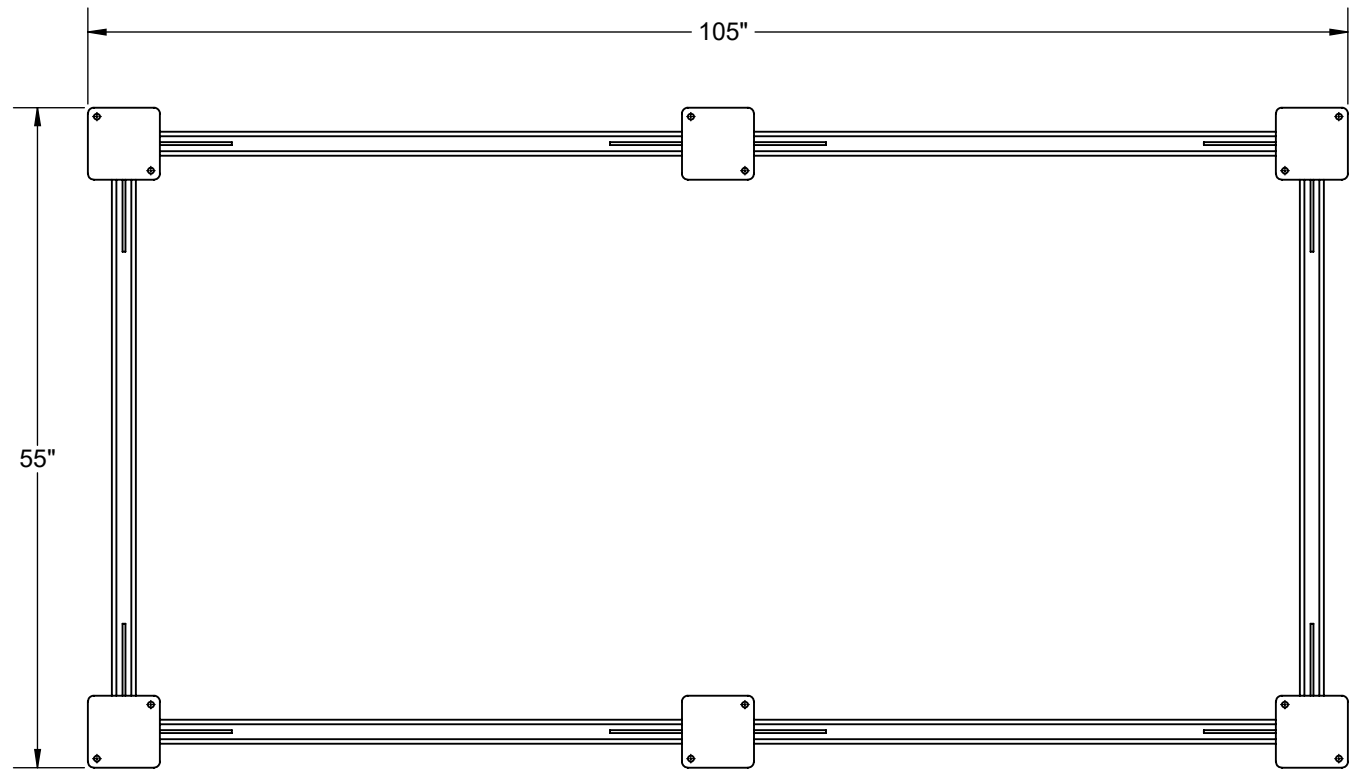

ADJUSTABLE FOOTPAD DETAIL

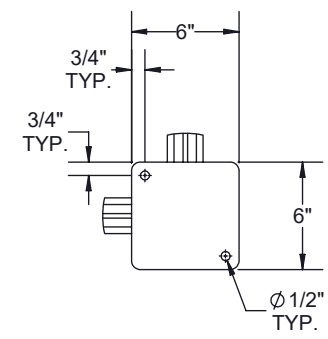

FOOT PAD DETAIL

CUSTOMER ACTION REQUIRED

CUSTOMER ACTION REQUIRED BLOCK	
SYSTEM TAG	SYSTEM ACCESS

CUSTOMER ACTION REQUIRED

APPROVAL PRINT

APPROVED APPROVED AS NOTED
 REVISE AND RESUBMIT
 SIGNATURE: _____
 DATE: _____

CUSTOMER: AIR FILTER SYSTEMS INC.
 CUSTOMER LOCATION: _____
 CUSTOMER PO NO.: _____
 CAMFIL ORDER NO.: Q241881
 CAMFIL PART NO.: _____

UNLESS OTHERWISE SPECIFIED, TOLERANCES ARE:
 FRACTION: ±1/8"
 DECIMAL: ±0.125"



GENERAL SYSTEM INFORMATION

DRAWN BY: JL DATE: 10/4/2024
 APPR. BY: JRR DATE: 10/4/2024

DWG SIZE	DRAWING NO.:	SHEET	OF	REV.
B	CB24-0222	2	2	0

[REMOVABLE COMPONENTS WITHIN AND/OR OUTSIDE OF THE WETTED AIRSTREAM MAY BE 300 SERIES STAINLESS STEEL UNLESS NOTED OTHERWISE.]

*DIRECTION OF ACCESS MUST BE SPECIFIED FOR INSTALLATION. TO DETERMINE DIRECTION OF ACCESS, IMAGINE THAT YOU ARE STANDING ON THE UPSTREAM END OF THE HOUSING SO THAT THE AIR FLOW WOULD STRIKE YOUR BACK. IF THE DOOR IS ON THE RIGHT (AS SHOWN), THEN THE UNIT IS RIGHT HAND ACCESS, IF THE DOOR IS ON THE LEFT, THEN THE UNIT IS LEFT HAND ACCESS.

REV.	DRAWN BY DATE	DESCRIPTION:	APPR. BY DATE

THE INFORMATION CONTAINED ON THIS DRAWING IS PROPRIETARY TO CAMFIL AND MAY NOT BE REPRODUCED NOR TRANSMITTED TO OTHER PARTIES WITHOUT THE CONSENT OF CAMFIL.

SCALE: 1:1



CamContain™ SBTB Damper

Bubble-Tight Rectangular Isolation Dampers

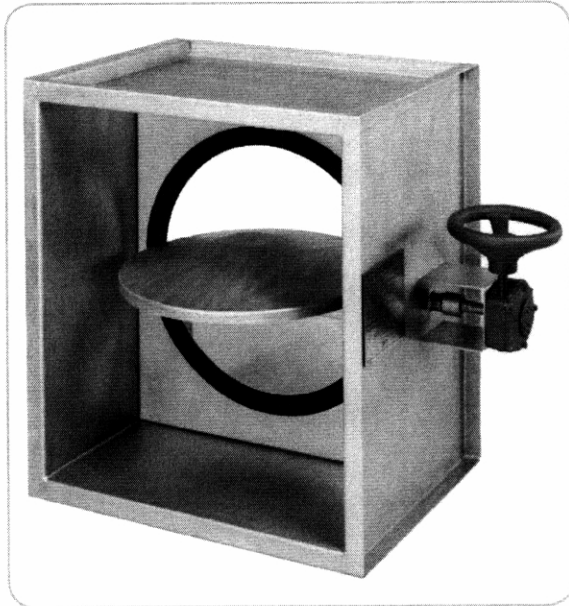

Camfil CamContain SBTB Rectangular Isolation Dampers create a barrier between hazardous contaminants and the filter change out components typical to a containment system. CamContain Rectangular Isolation Dampers are bubble-tight when tested to 10" w.g. Every CamContain SBTB includes:

- Housing is manufactured of 14 and 11-gauge T-304L stainless steel
- Is continuously welded at all pressure barrier points
- Includes a 20" nominal round damper dish (additional dish sizes are available). Damper sealing points incorporate memory intensive closed cell neoprene to create an effective seal for every filter change or decontamination procedure
- Factory-installed manual gear drive, pneumatic, or electronically activated actuators are available
- Includes pre-drilled out-turned standing flanges for connection to additional housings or existing hardware
- May be mounted in series or in parallel to meet most system isolation requirements.

Isolation Dampers to protect service personnel during filter change. Also designed to isolate filter section during filter decontamination procedure.

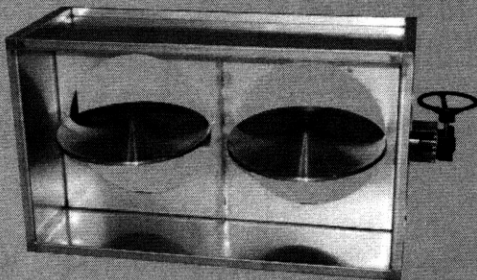

Dampers may be ganged up to 5 high by 6 across.

All Camfil CamContain SBTB Rectangular Isolation Dampers are manufactured to industry standard recommended practices and evaluation criteria.

Custom designs are also available to meet any individual containment requirement.

Applications

Isolation dampers create a positive shut-off and isolation of hazardous contaminants when incorporated in a containment system. During filter change the dampers are closed to ensure the safety of the filter service personnel during filter change.

Electric and pneumatic actuators may incorporate a fail-safe closed position (standard) or fail-safe open

position as required by the application. Consult factory with application requirements.

Isolation dampers are also used in systems where decontamination of system components are a part of the filter changing procedure.

Typically the dampers are closed, after which a decontamination substance (usually formaldehyde,

CamContain™ SBDT Rectangular Dampers

dependent upon the hazardous contaminants of concern) is introduced to the internal components of the isolated housing detoxifying biohazard components. Injection ports are required on the containment housing components for this process.

Right: Multiple dampers in a 3 high by 3 wide configuration.

Bottom: Dampers are typically used to safety seal filter housing section from process or air stream.

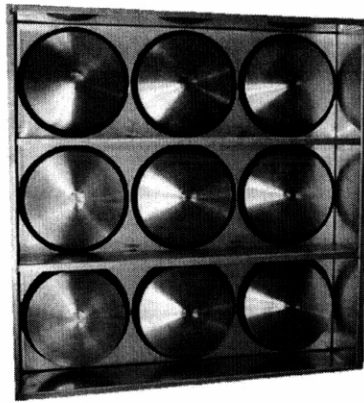
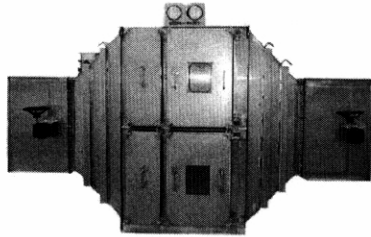

Typical Applications

Hospital Infectious Isolation Suites	Most common are systems for the control of mycobacterium tuberculosis, as isolation or decontamination dampers
Pharmaceutical Facilities	As part of the procedures for drug processing quality control
Food Processing	As part of a control system to prevent contamination of consumer goods, to protect plant personnel
Biotechnology Laboratories	To ensure genetic and biotech research is uncompromisable, or contained and eliminated for the protection of laboratory personnel, as isolation or decontamination dampers
University Laboratories	To ensure the safety of students, personnel and prevent the exhaust of harmful contaminants
Industrial & Chemical Manufacturing Facilities	To ensure the safety of personnel and prevent the exhaust of harmful contaminants
Nuclear Processing Facilities including utility power plants and research facilities	
Veterinary & Animal Research Facilities	
Military Facilities	
Semiconductor Manufacturing Facilities	

www.camfil.com

Model Number Information

CamContain™ SBDT Rectangular Dampers

Model Number	Damper Diameter (inches)	Actual Dimensions (inches)			Maximum Width (inches)	Weight (lbs)
		Height (A)	Width (B)	Depth (C)		
CF-1 x 1 - SBDT - 20 - M - SS	20	30	27	20	37	94
CF-1 x 2 - SBDT - 20 - M - SS	20	30	51	20	61	189
CF-1 x 3 - SBDT - 20 - M - SS	20	30	75	20	85	283
CF-2 x 1 - SBDT - 20 - M - SS	20	60	27	20	37	188
CF-2 x 2 - SBDT - 20 - M - SS	20	60	51	20	61	378
CF-2 x 3 - SBDT - 20 - M - SS	20	60	75	20	85	566
CF-3 x 1 - SBDT - 20 - M - SS	20	90	27	20	37	282
CF-3 x 2 - SBDT - 20 - M - SS	20	90	51	20	61	567
CF-3 x 3 - SBDT - 20 - M - SS	20	90	75	20	85	848
CF-4 x 1 - SBDT - 20 - M - SS	20	120	27	20	37	378
CF-4 x 2 - SBDT - 20 - M - SS	20	120	51	20	61	758
CF-4 x 3 - SBDT - 20 - M - SS	20	120	75	20	85	1132

Data Notes:

Unit is completely factory assembled.

Direction of access must be specified. To determine direction of access, imagine you are standing on the upstream end of the housing so that the airflow would strike your back. If the door is on the left, then the unit is left hand access; if the door is on the right then the unit is right hand access. There are many options when considering electric or pneumatic actuators. Some include solenoid valves and switches. Contact factory for assistance.



A, B and C dimension values in chart above.

Model Number Data

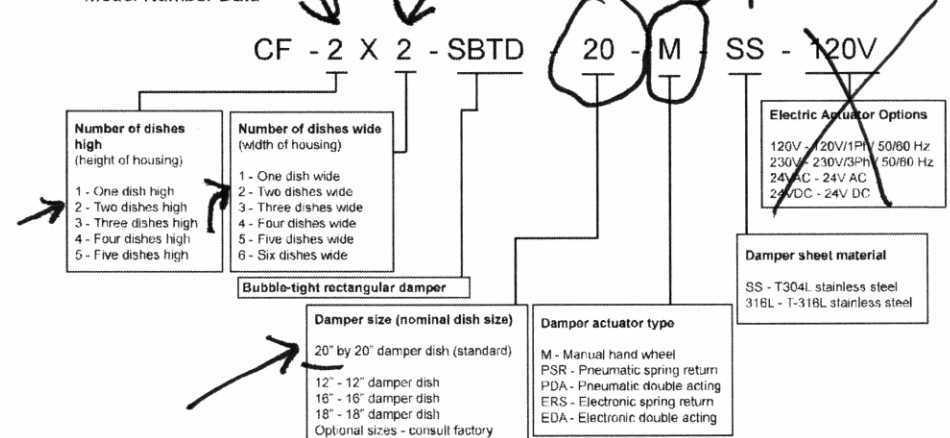

www.camfil.com



CamContain™ SBTB Damper

Bubble-Tight Rectangular Isolation Dampers

CamContain SBTB Specification

General

1.1 - Dampers shall be rectangular dish style type tested to be bubble-tight per ASME N510-1995 Reaffirmed.

1.2 - Quantity and application shall be as noted on enclosed drawings or other supporting documents.

2.0 Construction

2.1 - The damper shall be manufactured from 14 ga. and 11 ga. stainless steel sheet metal. The damper shall have a 20" (nominal) T-304L stainless steel, dish-shaped closure with a knife edge that seats against a 11 ga. stainless steel frame with a closed-cell neoprene gasket. The effect shall be a leak free gasket-to-knife edge seal. The damper shall have a 1-½" wide 11 ga. flange on the inlet and outlet with pre-drilled mounting holes. Bolt hole spacing is in accordance with the recommendation in DOE-HDBK-1169-2003, "Nuclear Air Cleaning Handbook" (4" inches or less on centers). The damper shall be adequately reinforced to withstand a negative or positive pressure of 15" water gage.

2.2 - All 'pressure retaining' weld joints and seams shall be continuously welded with no porosities allowed. Joints and seams requiring only intermittent welds, such as reinforcement members, shall be intermittently welded. Damper shall be free of all burrs, and sharp edges. All weld joints and seams that are a portion of any gasket sealing surface (duct connection flanges), shall be ground smooth and flush with adjacent base metals. All welding procedures, welders and welder operators shall be qualified in accordance with ASME Boiler and Pressure Vessel Code, Section IX. All welded joints and seams shall be wire brushed to remove heat discoloration.

(2.3 - Manual Actuator

The damper shall be factory equipped with a manual actuator with a hand wheel and quarter-turn manual worm gear. The actuator housing and cover are cast iron, worm gears are heat-treated carbon steel, worm wheels are cast ductile iron, input shafts are carbon steel, shaft and worm seals are Buna-N-Rubber, housing-to-cover seals are impregnated cellulose fiber, bushings are oil impregnated copper nickel steel alloy.)

(2.3 - Pneumatic Actuator

The damper shall be factory equipped with a pneumatic rotary type actuator with flow control valves.

(Customer to specify available air pressure.)

(2.3 - Electric Actuator

The damper shall be factory equipped with an electric rotary actuator. The motor shall be high-torque, single-phase, reversible, with a capacitor operated motor and factory set travel limit switches. The unit shall also be equipped with a motor brake. (Customer to specify speed and voltage)

3.0 Performance

3.1-All welding procedures, welders, and welder operators shall be qualified in accordance with ASME Boiler and Pressure Vessel Code, Section IX. All production welds shall be visually inspected by qualified personnel, per Camfil standard procedure number CFW-10001, Visual Inspection of Welds, which incorporates the workmanship acceptance criteria described in Sections 5 & 6 of AWS D9.1-1990. Specification for Welding of Sheet Metal.

3.2 -The damper shall be manufactured under a Camfil Quality Assurance Program (see Note 1 Below). The damper blade shall be tested in the closed position at +10" w.g. and shall be bubble tight when tested in accordance with ASME N510-1995 Reaffirmed, "Testing of Nuclear Air Cleaning Systems". The complete damper pressure boundary shall be leak tested at +15" water gage and have a maximum leak rate of 0.0005 cfm per cubic foot of housing volume.

3.3 - Manufacturer shall provide evidence of facility certification to ISO 9001:2008.

Note 1 (to specifying engineer): Camfil manufactures all of its containment products using more than one Quality Assurance Program. Our product-wide Quality Assurance Program is a stringent process that ensures the equipment is produced in conformance with our understanding of the intended application. However, this product-wide program does not address all the items specified in ASME-NQA-1. If this product must be manufactured under an ASME NQA-1 Quality Assurance Program, please add the following to this statement "including the basic requirements of ASME NQA-1." Please contact the factory if specific clarifications are required.

* Items in parentheses () denote optional selections. On this page this includes section 2.3.

For detailed specifications please consult your local Camfil Distributor or Representative or www.camfil.com.

Camfil has a policy of uninterrupted research, development and product improvement. We reserve the right to change designs and specifications without notice.



Direct factory assistance:
Telephone: (252) 975-1141
Fax: (252) 948-3636



Camfil | 1 North Corporate Drive, Riverdale, NJ 07457 | Tel: (973) 616-7300

www.camfil.com



CamContain FB Housing

Gel Seal Bag-In/Bag-Out Air Filter Housing

Gel Seal



The CamContain FB Series are Containment level housings designed for use in critical processes where hazardous airborne materials must be prevented from escaping the air filtration system. Air filters may be replaced using a control barrier to protect change-out personnel from contaminants within the housing or spent filters.

The CamContain FB Housing minimizes exposure to harmful contaminants during filter service through the use of a PVC bag enclosure system. The entire filter changing process isolates personnel from the hazardous materials.

The CamContain FB's standard configuration may be customized with various options specific to the application.

These housings are typically used in facilities where hazardous materials are encountered. These contaminants may include biomedical, radiological, carcinogenic, or other materials of concern.

Some applications include:

- Chemical manufacturing facilities
- Food processing
- Genetic research and biotechnology facilities
- Hospital Isolation Suites to prevent the spread of infectious diseases
- Industrial processes exhaust
- Microelectronic and semiconductor facilities
- Nuclear power plants
- Pharmaceutical facilities
- Radioisotope handling facilities
- University research laboratories
- US Department of Energy facilities
- Veterinary research and animal disease laboratories.

Gel seal technology to ensure complete capture of airborne contaminants

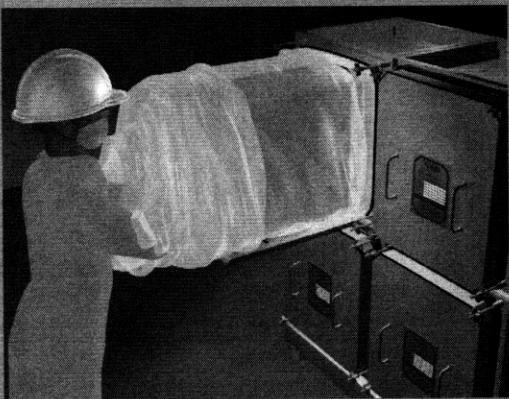

The highest level of personnel protection.

Containment Train Components

CamContain FB Housing



Figure 2

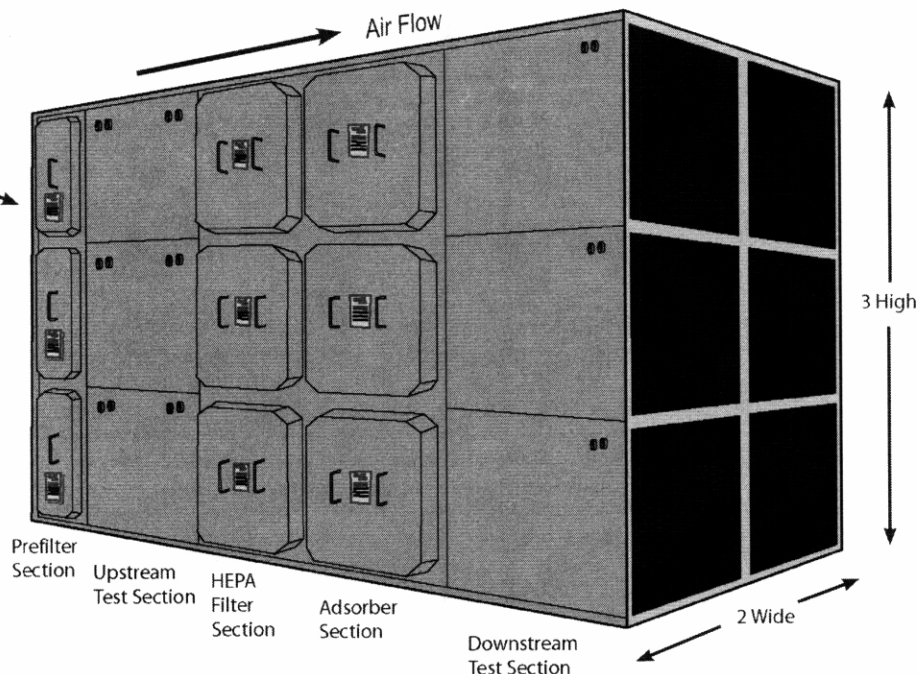

Figure 1

CamContain FB Housings are available in configurations from $\frac{1}{2} \times \frac{1}{2}$ (one filter 12" by 12" size) to configurations that are 1 filter high x 3 filters wide that allow up to three 24" by 24" filters from a single service door.

Units may be stacked or connected in series, depending upon the airflow requirements and contaminants of concern. The housing in Figure 1 shows a stacked unit that is 3 filters high by 2 filters wide and includes 3 stages of air filtration.

In many cases, air filtration standards are required by Federal or State mandates, or by recommended practices by other cognizant authorities. Every unit clearly identifies specific equipment details on a stainless steel label (Figure 2). The following components assure compliance with these mandates.

Prefiltration

CamContain FB Housings can incorporate a prefilter track to extend the life of the primary filters. Tracks may accommodate 2", 4", or 6" deep prefilters. Access to prefiltration may be through the same door as the final filter without disturbing final filter integrity. A separate door may also be provided for prefilter access only. Prefiltration efficiency typically ranges from a MERV 7 to a MERV 14 when evaluated under ASHRAE Filter Testing Standard 52.2.

Particulate Filters

Typically the primary filter in a containment system is a high efficiency particulate air filter (HEPA). Camfil Absolute (HEPA) filters are manufactured under strict quality control guidelines. Every filter is tested to ensure that the particulate efficiency meets or exceeds the requirements of

the application. Particulate filters are available from 99.97% on particles 0.3 micron in size to 99.9995% on particles 0.12 micron in size. All Camfil gel seal filter housings are fully welded to create a leak free seal between the housing filter mount and filter, thereby ensuring removal of harmful contaminants.

Standard Component Construction

Stainless Steel Construction

CamContain FB Housings are completely factory assembled and constructed of 11 and 14 gauge, 304/L and 316/L stainless steel sheet metal options. There are no painted surfaces nor use of carbon/mild steel materials. Each housing is warranted to withstand 15" w.g. positive or negative pressure without failure of the housing to ambient air seal or compromise of the overall housing integrity. Each housing is tested to this level and test reports are available on request.

Camfil has the ability to custom design housing integrity to most operating conditions. Consult the factory for specifications related to your application or other non-listed material component needs.

Removable Star-Style Door Knobs

Each door is secured through the use of four threaded studs with removable aluminum star knobs. After filter change, the knobs are tightened in an alternating pattern to ensure an even and secure housing seal.

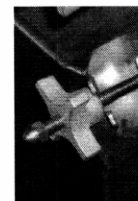

Access Door(s)

Access doors, of the same construction materials as the housing, include a built-in bagging ring cavity to store the filter change bag during system operation. Each access door includes a high-memory silicone gasket that recreates a positive housing to ambient seal after each filter change. Convenient door handles are optimally placed so the doors have a natural balance during filter change.

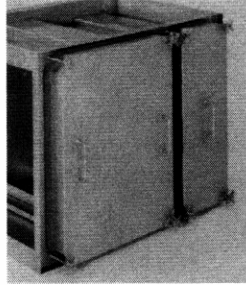

Dual Ribbed Bagging Rings

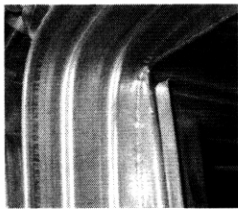

Each filter access port includes a ribbed bagging ring assembly for attachment of an 8-mil changing bag of polyvinyl chloride (PVC) construction. The bagging ring is continuously welded and hemmed to prevent damage to the bag.

Filter-Sealing Assembly

CamContain FB Housings incorporate a linkage clamping mechanism that is applied through the use of a locking arm from outside of the filter housing.

The housing includes a penetrating knife edge which inserts into a gel filled perimeter channel located on the face of the air filter. By engaging the filter sealing mechanism, the filter is moved to a position where the knife edge uniformly penetrates the filter's gel channel creating a leak free seal. Disengaging the filter sealing mechanism removes the filter free of the penetrating knife edge, enabling filters to be removed. Filter change is then performed within the filter change out bag.

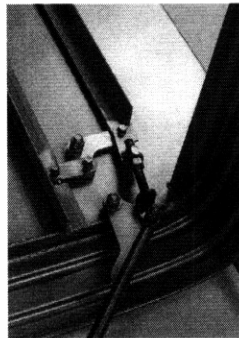

Dampers

Dampers allow isolation of components during filter change or decontamination processes. Camfil manufactures low-leakage and bubble-tight designs. Pneumatic and electric options are available. Consult Camfil Bulletin 3440.

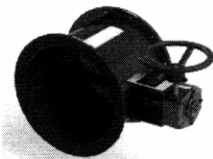

Decontamination Ports

Camfil can provide decontamination ports for the injection of materials designed to force neutralization of contaminants. This photo shows a plug sitting on top of the port assembly. Plug type is ring-seal positive.

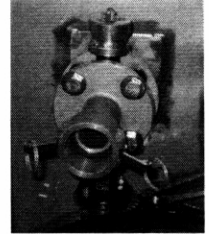

DOP/Freon Test Ports

To facilitate in-place filter evaluation, Camfil can supply integral tests ports for the sampling of the challenge aerosol.

Drilled Flanges

Camfil can provide pre-drilled duct connection flanges. Holes are typically 7/16" in diameter with spacing not to exceed 4" (per DOE-HDBK-1169-2003 "Nuclear Air Cleaning Handbook 4.4.14"). For a bolt hole drawing of your housing model, please consult factory.

Filter Change-Out Shelf

A filter change-out shelf provides support for the filters during the service process. Connecting conveniently to the door latches it can support filters and bagging components up to 300-lbs. Filter change-out shelves are highly recommended for housing applications where ladders may be required for service or housings in a difficult-to-reach location, or where heavy carbon adsorbers may be applied. Consult Camfil Bulletin 3410.

Lifting Lugs

Camfil can provide lifting lugs for unit transport and support during installation. The lugs are of 1/4" thick 304/L stainless steel and have a pre-drilled 2" hole. Common lifting lug locations include the top or side of the housing.

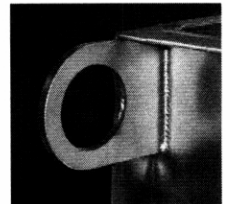

Plenums & Transitions

Camfil can manufacture all components required for complete system integrity. Matching plenums of the same construction as the housing are available to mate with existing equipment or ductwork. Transitions are also available to mate to equipment offsets.

Prefilter Housings

Camfil can provide integral prefilter sections for application of 2", 4", or 6" deep prefilters. Various prefilter configurations are available. Consult Camfil Bulletin 3403.

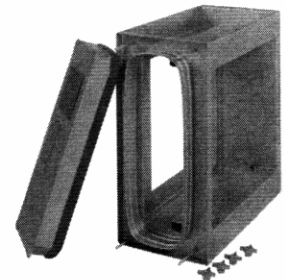

Pressure Gages

Camfil can provide factory-mounted differential pressure gages to evaluate resistance across individual filters or any combination of internal components. Gage connections include copper tubing and brass fittings. Stainless steel tubing and fittings are also available.

Pressure Taps (static)

Static pressure taps are available to facilitate the connection of gages or other ancillary equipment. For on-site application of gages, taps include a removable brass plug.

Security & Cinching Straps

Replacement straps are available. Consult Camfil Bulletin 3410.

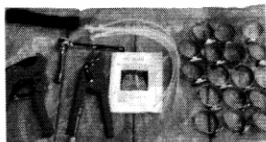

Swivel Door Latches

CamContain housings are available with swivel door latches to allow the latches to swing away from the filter change opening. Door latch components are captive as a precaution against dropping or losing them. Swivel door latches are highly recommended for housing applications where ladders may be required for service, or housings that are in a difficult-to-reach location.

Test Sections (in-place)

Test sections allow evaluation of filters without the on-site inline space penalties associated with the proper mixing of aerosol challenges. Standard test sections allow evaluation of an entire bank of filters. Scan test sections allow evaluation of individual filters to ensure that an individual filter does not have any leaks. All testing is accomplished without exposing the service personnel to hazardous materials contained by the housing. Consult Camfil Bulletin 3407 for standard test sections and scan test sections.

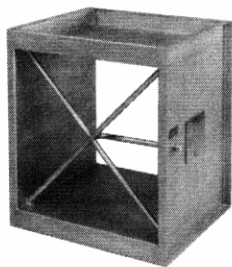

Additional Options

Contact Sales-WA@camfil.com for factory consultation.

Casters

CamContain Housings may be mobilized with casters to allow use of the units in alternate locations.

Certified Weld Inspection (CWI)

Visual weld inspection can be performed by a certified weld inspector qualified to Section 6.1 of the American Welding Society Standards For Qualification and Certification of Welding Inspections, QC1-96. The inspections will be performed under the guidelines of AWS D9.1M/D9.1.

Flanges

7 gauge brass or stainless steel plate flanges are available. The flanges can be furnished with 7/16" diameter holes no more than 4" on center as recommended in DOE-HDBK-1169-2003 "Nuclear Air Cleaning Handbook 4.4.14", or to mate-up with standard pipe flange bolt hole patterns. Standard raised-face, slip-on, stainless steel flanges per ANSI/ASME B16.5 are also available.

Deformation Testing

Non-destructive deformation testing is available. This test confirms systems will not deform at higher pressures.

Dye Penetrate Testing

Dye penetrate testing is available to evaluate for weld defects.

Electric Heaters

Electric heaters with pre-wired connection boxes are available.

High/Low Pressure Options

Camfil can assemble components to meet the pressure requirements of most applications.

High-Temperature Construction

Camfil housings are available with construction components that can accommodate process air to 450° F (232° C).

Humidifiers

Humidifiers are available to meet specific application needs.

Insulation

Housings may be insulated. All insulation incorporates double-wall housing construction.

Low Leak Testing

Low-leak testing to lower than standard leak rates is available.

Metal Door Pocket

A metal door pocket to store Operations & Maintenance Manual (O&M) during system operation is available.

Moisture Removal Drains & Valves

Moisture removal drains and valves are available. These are typically applied in installations that have concerns with regard to condensation, or if moisture separators are used in the system.

Moisture Separators

Moisture separators applied as prefiltration are available. Camfil moisture separators have an efficiency of 98% on 5-micron size droplets. Other variations of moisture separators are available (consult factory).

Mounting Bases

Custom mounting bases are available. These are applied for seismic security or to match a roof curb.

Mounted Fans/Controls

Camfil will assemble complete trains of containment systems that can include particulate filtration, gaseous filtration, and ancillary components such as fans and controls.

Seismic Qualification

CamContain FB Housings can be purchased with a special seismic certification in accordance with the criteria of the International Building Code (IBC 2015) and/or California Building Code (CBC 2016). Multiple module systems consisting of filter housings, test sections, dampers, etc. can be certified per application to meet most levels of severe seismic requirements. The current maximum code required seismic certification level is a Component Importance Factor $I_p=1.5$, Short Period Design Acceleration $S_d=2.0g$, and Height Ratio $z/h=1.0$ (roof level mounted). Additional information to provide assurance of special seismic certification requires factory consultation.

For nuclear projects, seismic qualifications per IEEE 344 is available via analysis and/or seismic testing under ASME NQA-1 Quality Assurance program for both structural integrity and anchorage and functionality requirements. Consult factory for project purchase specification and seismic requirements specification.

The Complete System

Camfil manufactures all of the components required in a containment train of housings. Performance and protection from one source, Camfil, a worldwide leader in air filtration technology and production.

Quality Assurance

Camfil has quality control initiatives that ensure our products meet or exceed industry standards set forth by cognizant authorities, including the United States Government. These programs are inclusive of raw materials acquisition, procedures of transport and storage, preparation and assembly of these materials to a final product form, and the testing and qualification.

Camfil Safety and Protection production facilities have been audited by various entities and found to be acceptable. These procedures are part of a living doctrine that is updated based upon improved technologies and the increased needs of the applications. Camfil containment products are manufactured under a Camfil Quality Assurance program, including the basic requirements of ASME NQA-1 when specified.

Camfil Absolute filters and ASHRAE grade filters that may be used in containment applications are manufactured in ISO 9001:2001 facilities. Camfil Nuclear Grade Absolute filters complying with the requirements of Section FC of ASME AG-1, are manufactured under an ASME NQA-1 Quality Assurance Program.

Additional quality assurance procedures are in place to meet the needs of specific end users. These procedures are available for review and modification by end users, our authorized representatives, and Camfil.

Contact the factory at Sales-WA@camfil.com for additional information.



Bag-In/Bag-Out Concept

CamContain FB Housing

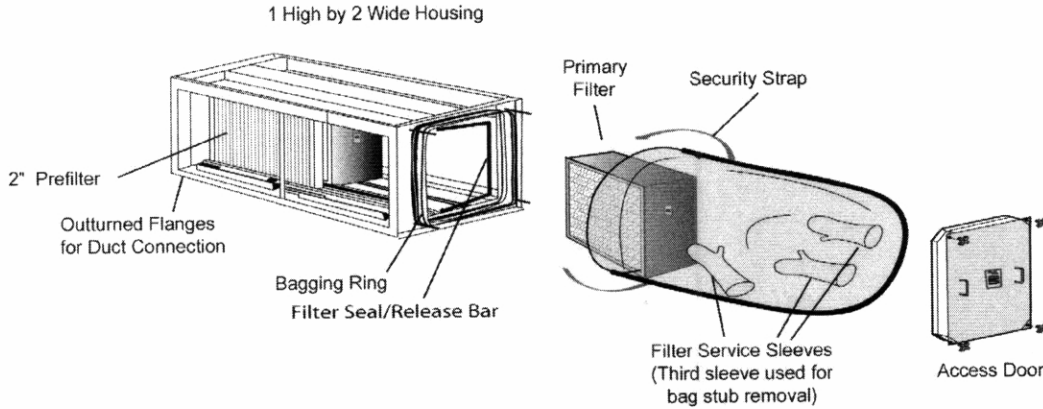

CamContain FB Housings are designed with safety in mind. Each housing is shipped with an instruction book detailing how to change the filters. The basics of filter change include installing the new filters in the change-out bag, securing the bag over the ribbed openings on the housing door opening, and performing the filter change entirely within the bag.

STEP 1

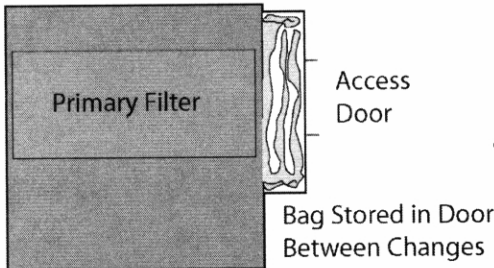

During operation the filter (s) are in place and the bag is stored in the door

STEP 2

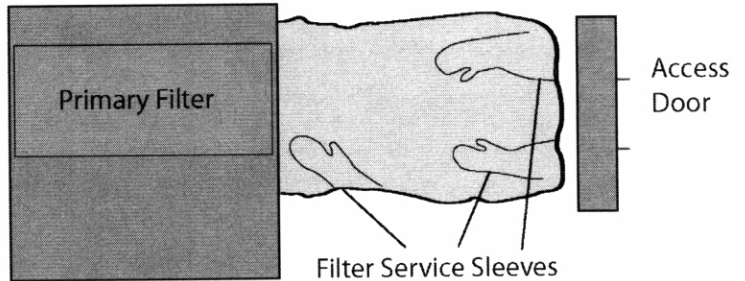

After removing the access door, extend the bag, and use the bag gloves to carefully move the contaminated filter into the bag.

STEP 3

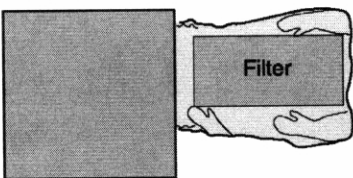

Remove the contaminated filter from the housing, supporting the filter on a table, or optional change-out tray.

STEP 4

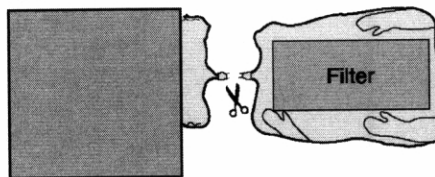

Seal the bag with banding ties between the filter and the door opening. Cut the bag with shears to contain the used filter.

STEP 5

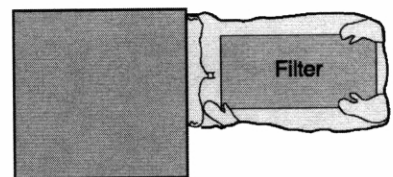

Place a new filter in a new bag and secure the new bag opening to the housing door opening. Move the old bag stub into the new bag cavity and install the filter.

STEP 6

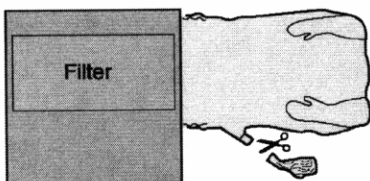

Move the old bag stub into the third service glove sleeve and seal the sleeve with banding ties between the bag body and the glove sleeve.

STEP 7

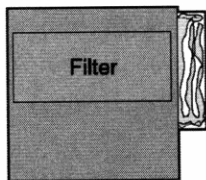

Carefully fold the bag and place in the door cavity. Replace door.

Bagging Flange Detail

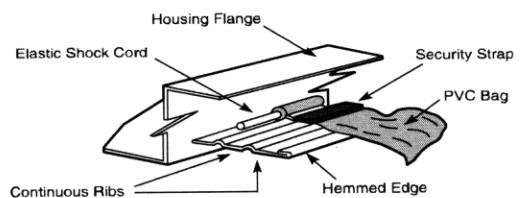

The illustration above portrays how the bag is placed over the ribs and held in place there by an elastic shock cord and security strap.

Model Designator

HEPA Housing

CF-2XZ-012P-1FB-SS CamContain FB Housing

~~CF-3X3-412P-3FB-SS~~

Number of Filters High
(height of housing)

- ½ = One (1) filter high (half size)
- 1 = One (1) filter high
- 2 = Two (2) filters high
- 3 = Three (3) filters high
- 4 = Four (4) filters high
- 5 = Five (5) filters high
- 6 = Six (6) filters high

Number of Filters Wide

- ½ = One (1) filter wide (half size)
- 1 = One (1) filter wide
- 2 = Two (2) filters wide
- 3 = Three (3) filters wide
- 4 = Four (4) filters wide
- 5 = Five (5) filters wide
- 6 = Six (6) filters wide

Pre-filter Size
(depth of prefilter)
(height and width to match nominal dimensions)

- 0 = No prefilter
- 2 = 2" Deep prefilter
- 4 = 4" Deep prefilter
- 6 = 6" Deep prefilter

Primary Filter Size
(depth of primary filter)

- 12 = 11½" Actual filter depth
- 16 = 16" Actual filter depth
- 18 = 18" Actual filter depth

CF- 1X1-012P-1FB-SS will require a filter with actual dimensions of 24" X 24" X 11½"

Housing Sheet Metal Type

- SS = 304/L Stainless steel (standard)
- AS = Aluminized steel
- 316/L = 316/L Stainless steel

Housing Type/Series

- GB = Gasket seal bag-in/bag-out
- GN = Gasket seal non-bag-in/bag-out (Camfil Bulletin 3405)
- FB = Gel seal bag-in/bag-out (Camfil Bulletin 3401)
- FN = Gel seal non-bag-in/bag-out (Camfil Bulletin 3404)

Access Door Arrangement

- 1* = One (1) access door on one side of housing
- 2 = Two (2) access doors, one access door on each side of housing
- 3 = Two (2) access doors on one side of housing only, one door for prefilter, one door for primary filter
- 4 = Four (4) access doors, two on each side of housing, one for prefilter access, one for primary filter access

* Housing can only accommodate 2" deep prefilter and primary filter

Filter Type

- P = Particulate (HEPA)
- C = Carbon adsorber (HEGA)

Pre-filter
CF-2XZ-
200-1PB-SS

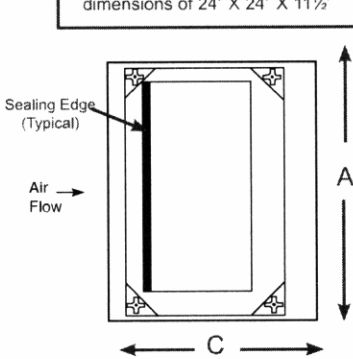

Typical door arrangement 1 with a single primary filter. Designed to accommodate primary filter (s) through one door opening. Actual primary filter depth may be 11½", 16" or 18".

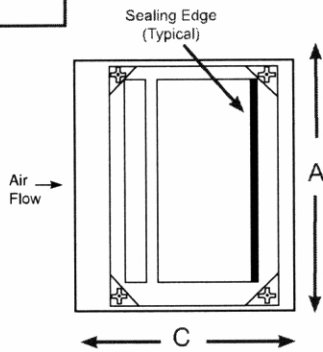

Typical door arrangement 1 with prefilter and primary filter. Designed to accommodate prefilter (s) and primary filter (s) through one door opening. Prefilter depth limited to 2". Primary filter depth may be 11½", 16" or 18".

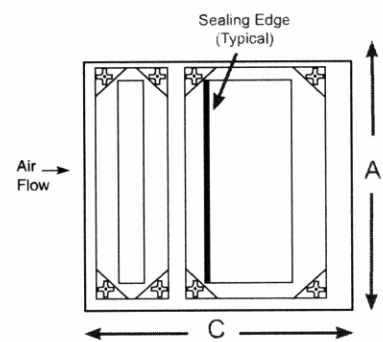

Typical door arrangement 3 with dual access doors. Designed to accommodate prefilter (s) and primary filter (s) through separate access doors. Prefilter depth may be 2", 4", or 6". Primary filter depth may be 11½", 16" or 18".

Housing Dimension A = Height B = Width C = Depth

Above arrangements show upstream, downstream and upstream primary filter seals respectively. Arrangements 1 and 3 are also available with downstream primary filter seal when in-place scan testing is required.

CamContain FB Housing

Left Hand Access

Right Hand Access

1 high by 3 wide

1 high by 1 wide with prefilter section.

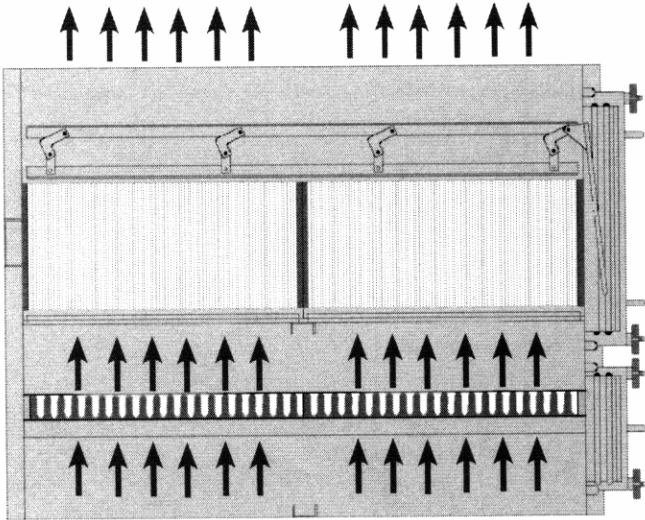
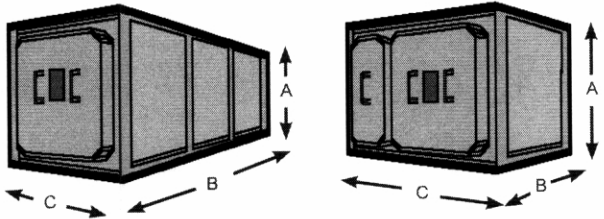
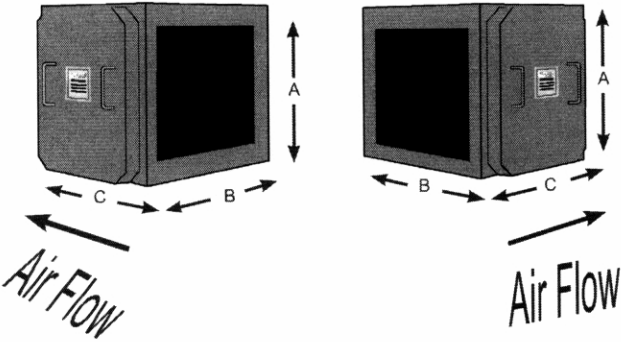

CamContain housings feature smooth surface construction. Pocket areas, that would allow contaminant build-up are minimized. All pressure retaining joints on the interior of the housing are continuously welded.

For detailed specifications or drawing, please consult your local Camfil Distributor or Representative or download from the Containment Toolbox located in the **Segments Tab** of **CamTab File Archive** at www.camfil.us.

Camfil has a policy of uninterrupted research, development and product improvement. We reserve the right to change designs and specifications without notice.

For assistance specific to this product, please contact Camfil Washington, NC facility at Sales-WA@camfil.com or by telephone at 877-658-6588.

Housing Size - H x W		
Housing Size (H x W)	Dimension A (inches)	Dimension B (inches)
1/2 x 1/2	18	15
1/2 x 1	18	27
1 x 1	30	27
1 x 2	30	51
1 x 3	30	75
2 x 1	60	27
2 x 2	60	51
2 x 3	60	75
3 x 1	90	27
3 x 2	90	51
3 x 3	90	75
4 x 1	120	27
4 x 2	120	51
4 x 3	120	75

Housing Size - Depth	
Model Number	Dimension C (inches)
012-1FB	26
016-1FB	30
018-1FB	33
212-1FB	30
216-1FB	34
218-1FB	36
212-3FB	38
216-3FB	42
218-3FB	44





CamContain Testing Solutions

A Guide

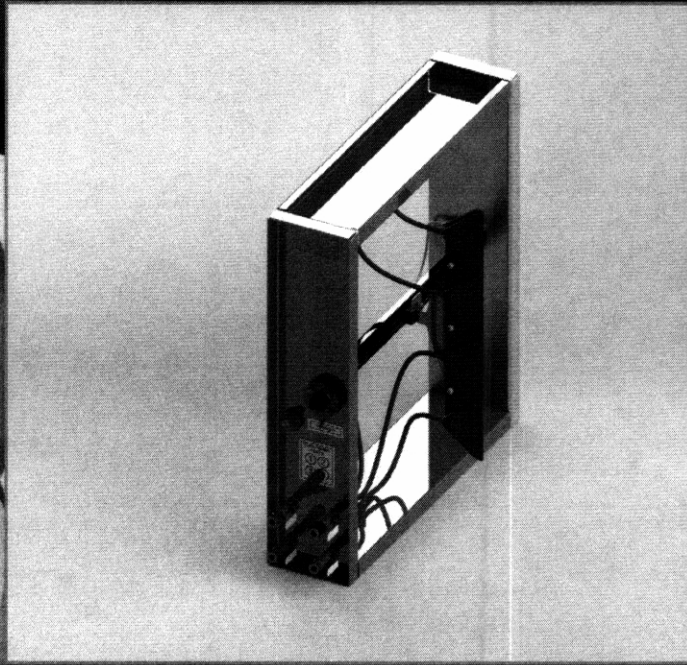

**Testing Solutions for
Containment Systems**

CLEAN AIR SOLUTIONS

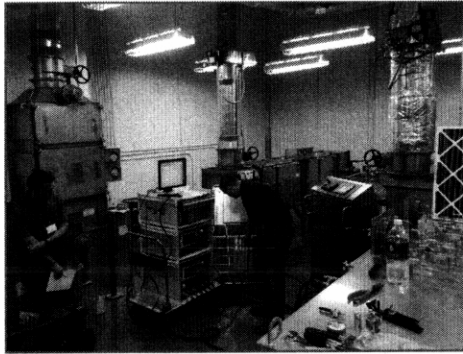

Installed Absolute® (HEPA) filters should be field tested to verify they are performing as specified. Each Absolute filter will have passed factory performance testing to verify that they perform to industry standards and meet the filter model's rated efficiency. However, between that factory testing and the installation into a filter housing, much can happen.

Damage can occur during shipping, or installation and handling, even by experienced and trained personnel. Once installed, the filter-to-mounting-frame seal interface may have some by-pass. These and other factors can result in an installed filter element that no longer maintains its minimum required efficiency.

There are various test procedures to determine whether an installed filter bank performs per its designed intent. Of these test procedures, there are basically three commonly used in the field. They are:

1. Overall average efficiency of the entire filter bank test
2. Individual filter average efficiency test
3. Filter scan test

All these field tests generally involve four main elements (See illustration "There are 4 main elements to filter testing," on page 3):

1. Test aerosol injection
2. Aerosol mixing
3. Aerosol uniformity at filter
4. Downstream sampling

Each of these elements is important in order to achieve a satisfactory field test.

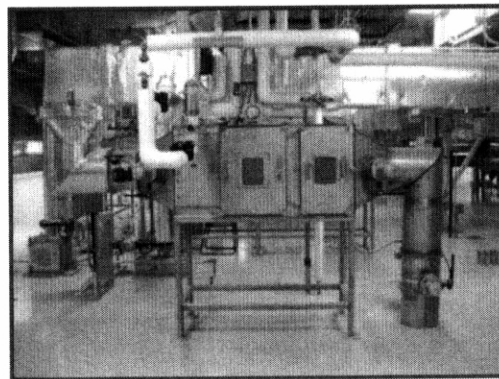

- Safe to use
- Validated designs meet code requirements
- Accurate and repeatable results
- Non-intrusive filter testing solutions

OVERALL FILTER BANK TESTING

What about ten duct diameters?

A rule of thumb maintains that injecting test aerosol 10 duct diameters upstream of a filter is adequate for thorough mixing to occur. This rule is referenced by many engineering publications. However, there is evidence this is not true in some situations. Typically for the "10 duct diameter" rule to work, the duct run should be straight and not interrupted by elbows or other obstructions. In practice, having the necessary mechanical space to achieve this mixing is rare. Typically, filter housings are placed in very tight spaces. Even 10 straight duct diameters may not achieve the necessary mixing desired. Regardless of the duct run length, the upstream face of the filter bank must be validated to have consistent air/aerosol uniformity.

There are 4 main elements to filter testing.

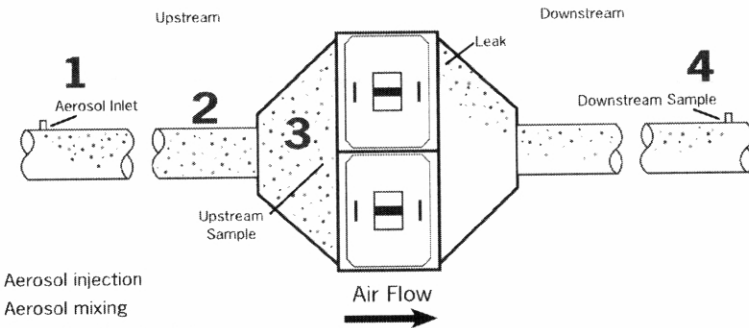

1. Aerosol injection
2. Aerosol mixing
3. Aerosol uniformity at filter
4. Downstream sampling

Overall filter bank test. This test method is the simplest and the least expensive. A test aerosol is injected upstream of the filter bank. The injection point is critical because the test aerosol must be thoroughly mixed with the process stream. This mixed aerosol is sampled just upstream of the filter bank. For the test to be valid, the air/aerosol mixture must be uniform across the face of the filter bank. There are many factors that may affect the in-place test results of installed Absolute® filter banks.

The following have a major effect on the measured Absolute bank efficiency:

- airflow rates
- prefilter efficiency
- prefilter loading
- location of the injection point
- method of injection
- upstream sample line location and sample method
- downstream sample line location and sample method.

In a paper presented at the 29th Nuclear Air Cleaning Conference, it concluded "...it is possible to have eight different test results without changing the size or location of the leak. Test results ranging from 'passing' to 'failing' can be obtained on the same system depending on the test technique and methodology." This paper highlights one of the deficiencies inherent to this test method, namely test consistency or repeatability.

OVERALL EFFICIENCY TEST SOLUTIONS

Camfil overall efficiency test sections:

- Are specially designed to attach directly to other Camfil containment modules ensuring complete system integrity from a single source manufacturer
- Are manufactured from the same materials as the containment section
- Are tested to the same design criteria as the other containment sections.
- Allow individual filter testing
- Are designed to protect test technicians from potential exposure to the contaminated airflow
- Incorporate a unique cross-sampling tube array that ensures overall filter efficiency detection for each filter located within the bank.
- Features a stationary mixing system that ensures the test condition matches the process conditions.
- Have sampling ports furnished to connect operator-supplied testing equipment.
- Are validated and documented to operate per ASME N-510 (Testing of Nuclear Air Treatment Systems) and the ASME AG-1 Code requirements

Absolute® filter test housings have been used successfully in nuclear applications for more than 30 years. While these test housings can test individual HEPA filter elements, the result is

an average measure of the penetration across the face area of each filter.

Camfil Overall Efficiency Test sections are utilized whenever injection of a test aerosol at a single point does not result in the required distribution of the agent uniformly across the face of the filter being tested or where single point sampling on the downstream of the filter does not allow the space for uniform mixing. Test sections provide a validated means to simulate ideal mixing conditions and provide a much greater likelihood of identifying leakage that could otherwise be missed from single point sampling due to limited access to the ductwork. Several publications (e.g. DOE-HDBK-1169-2003, Nuclear Air Cleaning Handbook) maintain 10 duct diameters is adequate for thorough air/aerosol mixing to occur but there is evidence that this is not true in some situations. Regardless, common testing protocols require injection and downstream sampling to occur at least 10 straight duct diameters from the filter bank. This protocol is designed to ensure adequate mixing of the test aerosol prior to the filter bank. The downstream requirement is usually sufficient to adequately mix the filter discharge to obtain a test sample. However, providing long duct runs up and down stream of filter banks is not always practical. Camfil test sections are designed and validated to replicate the mixing conditions of 10 duct diameters in a short length. In addition these test sections can sample each HEPA filter in a bank.

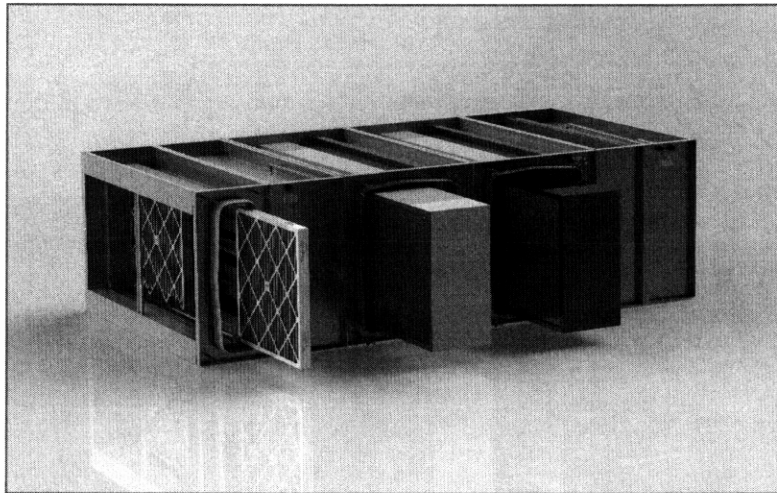

WHY A FIXED AEROSOL MIXING (BAFFLE) SYSTEM?

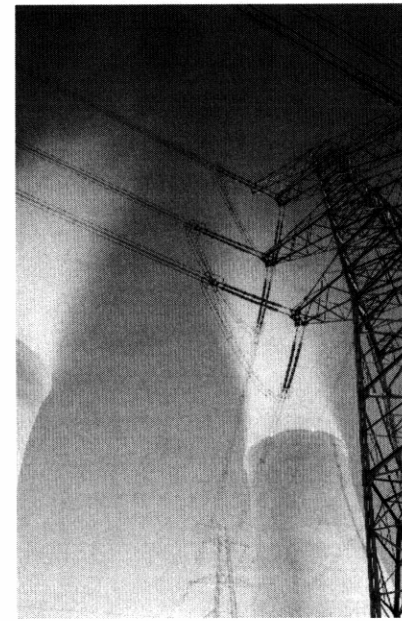
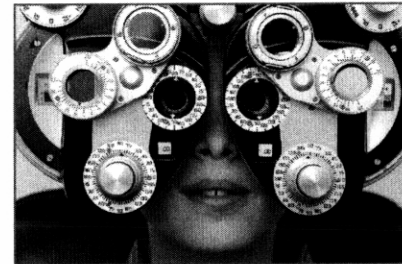

Would you take an eye exam wearing glasses? Of course not. Why? Because the results of your examination would not represent the condition of your eyes. To reduce system pressure drop and subsequent operating costs, some manufacturers furnish swing-away or rotating aerosol mixing systems. As a sustainable company, Camfil does not take excessive pressure drop lightly. The reason for adding a test section into a housing assembly is to ensure uniform aerosol distribution at the face of the filter element. If altering the internal airflow for testing creates the desired aerosol uniformity why should this condition only exist in the "test mode?"

The test condition should equal the operating condition within a filter housing. Otherwise the filters may not load uniformly resulting in premature change outs. While we respect the intent (i.e. energy savings), having a test condition that is different from the operating condition is not accurate and gives a false impression of the condition of the filter element.

Nuclear Series and Professional Series Containment Solutions

Camfil manufactures two series of Containment housings. The primary difference between these two series is the documentation related to nuclear quality assurance requirements. We use the same welders who have been qualified per the American Society of Mechanical Engineers (ASME) nuclear code, the same grades of stainless steel, and we qualify every testing housing section per the rigorous nuclear code.

The Nuclear Series is designed and fabricated in strict accordance with the latest version of ASME AG-1 nuclear code. All quality assurance procedures are in accordance with ASME NQA-1.

While the Professional Series has the same pedigree as the Nuclear Series, this Series is designed to more closely align with the requirements of the biosafety industry. The Homeland Security and Healthcare industries can also benefit from the features of this Series.

There are five different overall efficiency test section models, each with a specific function.

Upstream Injection Test Sections: TSU – Injection (Nuclear Series)
PTU – Injection (Professional Series)

Also known as an INJECTION section. This section is typically located upstream of the Absolute® filter bank to be tested. It is designed to inject a test aerosol, mix the aerosol and take a reference sample of the air/aerosol mixture.

TSU – Injection (Nuclear Series)

This TSU injection test section is modular and aligns with the entire filter housing system. This housing injects challenge particulate upstream of each individual filter element, reducing the mass of challenge particulate required to test an entire filter bank. This testing section may be used with the following Camfil testing sections: TSC | TSD | PTD

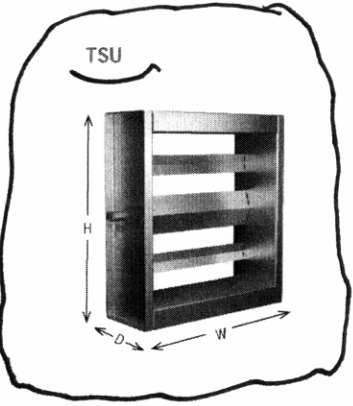

Standard Size	Number of Injection Ports	Number of Sampling Ports	TSU (Injection Test Sections)			
			Height (inches)	Width (inches)	Depth (inches)	Shipping Weight (pounds)
1 x 1	1	1	30	27	14	57
1 x 2	2	2	30	51	14	97
1 x 3	3	3	30	75	14	138
2 x 1	2	2	60	27	14	87
2 x 2	4	4	60	51	14	143
2 x 3	6	6	60	75	14	201
3 x 1	3	3	90	27	14	117
3 x 2	6	6	90	51	14	189
3 x 3	9	9	90	75	14	264
4 x 1	4	4	120	27	14	147
4 x 2	8	8	120	51	14	235
4 x 3	12	12	120	75	14	327

TSC – Injection / Sample (Nuclear Series)

This TSC sample test section is modular and aligns with the entire filter housing system. If a filter housing assembly includes more than one HEPA filter bank in series, a combination housing will be required between those filter sections. As its name implies, a combination test section performs the function of both the TSU and TSD in a single section. This testing section may be used with the following Camfil testing sections: TSU | PTU | TSD | PTD

TSC

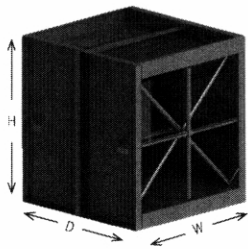

Standard Size	Number of Injection Ports	Number of Sampling Ports	TSC (Injection/Sample Test Sections)			
			Height (inches)	Width (inches)	Depth (inches)	Shipping Weight (pounds)
1 x 1	1	1	30	27	28	215
1 x 2	2	2	30	51	28	360
1 x 3	3	3	30	75	28	505
2 x 1	2	2	60	27	28	380
2 x 2	4	4	60	51	28	645
2 x 3	6	6	60	75	28	900
3 x 1	3	3	90	27	28	545
3 x 2	6	6	90	51	28	930
3 x 3	9	9	90	75	28	1295
4 x 1	4	4	120	27	28	710
4 x 2	8	8	120	51	28	1210
4 x 3	12	12	120	75	28	1690

Overall Efficiency Test (Sample) Sections: TSD – Sample (Nuclear Series)
PTD – Sample (Professional Series)

Also known as a SAMPLE section. This section is typically located downstream of the HEPA filter bank. Its purpose is to sample the downstream penetration of the test particulate challenge.

TSD – Sample (Nuclear Series)

The TSD sample test section is modular and aligns with the entire filter housing system. This housing includes a proprietary tubing system to sample any challenge particulate downstream of each individual filter element. This testing section may be used with the following Camfil testing sections: TSU | PTU | TSD | TSC

TSD

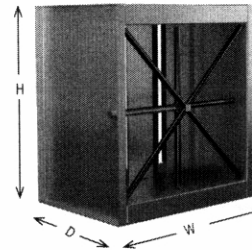

Standard Size	Number of Injection Ports	Number of Sampling Ports	TSD (Injection Test Sections)			
			Height (inches)	Width (inches)	Depth (inches)	Shipping Weight (pounds)
1 x 1	0	1	30	27	22	165
1 x 2	0	2	30	51	22	270
1 x 3	0	3	30	75	22	375
2 x 1	0	2	60	27	22	285
2 x 2	0	4	60	51	22	480
2 x 3	0	6	60	75	22	660
3 x 1	0	3	90	27	22	410
3 x 2	0	6	90	51	22	685
3 x 3	0	9	90	75	22	945
4 x 1	0	4	120	27	22	535
4 x 2	0	8	120	51	22	895
4 x 3	0	12	120	75	22	1230

Overall Efficiency Test Sections: TSC – Injection / Sample (Nuclear Series)

PTU – Injection (Professional Series)

The PTU is installed in the inlet duct (typically downstream of the inlet isolation damper) and injects challenge particulate across the entire face of the filter bank. This testing section may be used with the following Camfil testing sections: TSC | PTU | TSD

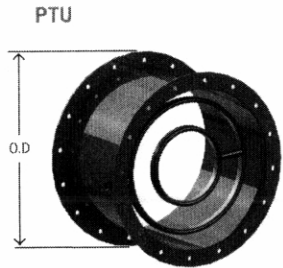

Dimensions - PTU						
Nominal Size	Inside Diameter (inches)	Flange O.D. (inches)	Bolt Circle (inches)	Number of Holes	Bolt Hole Diameter (inches)	Weight (pounds)
*	*	*	*	*	7/16	*
14	14	17	15.5	16		25
20	20	23	21.5	20		35
*	*	*	*	*	*	*

* Contact factory

iBTFB - integrated Bubble Tight Flat Blade

The integrated Bubble Tight Flat Blade damper offers two functions in one product, challenge particulate injection and functions as an isolation damper. The integrated damper/test section can be utilized on factory installed equipment or retrofit solutions. iBTFB

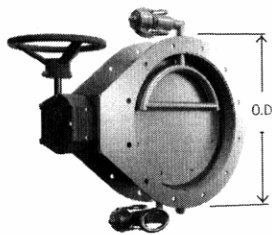

Dimensions - PTU						
Nominal Size	Inside Diameter (inches)	Flange O.D. (inches)	Bolt Circle (inches)	Number of Holes	Bolt Hole Diameter (inches)	Weight (pounds)
*	*	*	*	*	7/16	*
12	12	15	13.5	16		27
*	*	*	*	*		*

PTD – Sample (Professional Series)

The PTD is installed in the outlet duct (typically upstream of the outlet isolation damper) and samples challenge particulate from the filter bank. This testing section may be used with the following Camfil testing sections: TSU | PTU | TSC

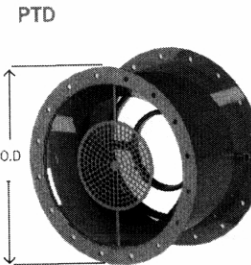

Dimensions - PTD						
Nominal Size	Inside Diameter (inches)	Flange O.D. (inches)	Bolt Circle (inches)	Number of Holes	Bolt Hole Diameter (inches)	Weight (pounds)
*	*	*	*	*	7/16	*
14	14	17	15.5	16		27
20	20	23	21.5	20		40
*	*	*	*	*	*	*

* Contact factory

SafeScan-A (Automated)

Camfil SafeScan-A test sections are the most accurate and reliable field testing device available for a containment filter assembly. The Camfil SafeScan-A mechanically-driven non-intrusive filter scanning solution was designed to overcome many of the risks associated with hand-operated scanning. Like all Camfil test sections, SafeScan sections facilitate in-place testing without personnel exposure to the inside of the filter housing.

Camfil SafeScan-A non-intrusive mechanical test sections:

- Are specially designed to mount directly to other Camfil containment modules ensuring complete system integrity from a single source manufacturer
- Are manufactured from the same materials as the containment section
- Are tested to the same design criteria as the other containment sections.
- Allow individual filter testing
- Are designed to protect test technicians from potential exposure to the contaminated airflow
- Incorporate patented mechanical scanning technology designed to scan the entire face of the tested filter element, including the gasket interface.
- Have color-coded and mechanically-keyed quick disconnect sampling fittings furnished to connect to a Camfil Scanning Control System.
- Have a quickly coupled mechanical drive interface connection.
- Are validated and documented to operate per
 - A. IEST-RP-CC034.2, HEPA and ULPA Filter Leak Tests
 - B. EN1822-4:2000, Unidirectional High efficiency particulate air filters (HEPA and ULPA) –Part 4: Determining leakage of filter element (Scan Method)
 - C. ISO/FDIS 14644-3:2004(E): Cleanrooms and associated controlled environments – Part 3: Test methods
- Test sections are available in modules up to three filters wide.
- Available in modules up to three filters wide.

As noted above, the SafeScan-A includes mechanically driven sensing probes. Operating a SafeScan-A test section requires a Camfil CamControl system or the Motion Control Lite (also called "MC Lite"). The most cost effective and simple solution is to use the MC Lite unit to drive the scan assembly. In addition to the MC Lite unit, this option would require the filter testing technician to use all the equipment normally used for a manual scan test (i.e. photometer, aerosol generator, etc.). The advantage is the technician would not have to manually move the scan probe while working through a bag. It is much easier, safer and the results are more reliable and repeatable using our non-intrusive automated scan section as compared to a hand operated scan test sections.

The CamControl option is a fully automated control and test equipment package which does all the testing, data acquisition, and reporting automatically once you make all the connections to our containment systems. In addition to scan testing you are able to conduct pressure decay testing, and average efficiency testing. This unit is more expensive than a MC Lite but is completely secure, self-contained, and offers significant advantages to users who have many containment systems to test on their site. Camfil can train and certify technicians on how to use this valuable piece of equipment. Typically, we go to the site to conduct an initial start-up and training when these systems are purchased.

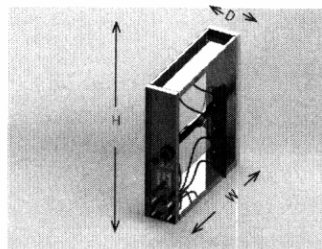

SafeScan-A (Automated Scan Test Section)				
Standard Size	Height (inches)	Width (inches)	Depth (inches)	Shipping Weight (pounds)
1 X 1	30	27	7	46
1 X 2		51		60
1 X 3		75		67
2 X 1	60	27		92
2 X 2		51		120
2 X 3		75		134
3 X 1	90	27		138
3 X 2		51		180
3 X 3		75		201
4 X 1	120	27		184
4 X 2		51		240
4 X 3		75		268

SafeScan-M (Manual)

SafeScan-M is the industry's first non-intrusive manual filter scanning solution. Loss of containment due to a torn or loose scanning bag is eliminated. Accidental probe contact with the HEPA filter media is eliminated. Using a photometer or portable particle counter, the test technician can safely scan test the installed filter (even challenge the filter seal integrity). Please note that manually scanning very high flow Absolute® filters (like the Filtra 2000) is not practical or recommended. Properly scanning these filter types requires scanning speeds much slower than that required for standard and high capacity HEPA filters. If very high flow Absolute® filters are required or specified, select the SafeScan-A scan section.

Camfil SafeScan-M non-intrusive test sections:

- Are specially designed to mount directly to other Camfil containment modules ensuring complete system integrity from a single source manufacturer
- Are manufactured from the same materials as the containment section
- Are tested to the same design criteria as the other containment sections.
- Allow individual filter testing
- Are designed to protect test technicians from potential exposure to the contaminated airflow
- Incorporate patented scanning technology designed to scan the entire face of the tested filter element, including the sealing surface interface
- Have quick disconnect sampling fittings
- Are validated and documented to operate per ASME N-510 (Testing of Nuclear Air Treatment Systems) and the ASME AG-1 Code requirements
- Test sections are available in modules up to three filters wide.
- Test Sections are available in modules up to three filters wide.

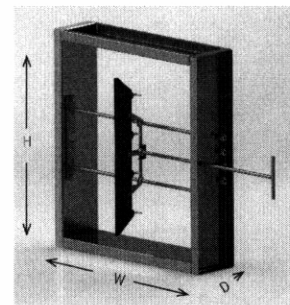

SafeScan-A (Automated Scan Test Section)				
Standard Size	Height (inches)	Width (inches)	Depth (inches)	Shipping Weight (pounds)
1 X 1	30	27	7	46
1 X 2		51		60
1 X 3		75		67
2 X 1	60	27		92
2 X 2		51		120
2 X 3		75		134
3 X 1	90	27		138
3 X 2		51		180
3 X 3		75		201
4 X 1	120	27		184
4 X 2		51		240
4 X 3		75		268

Camfil FB-Series Fluid Seal Bag-in/Bag-out Filter Housing

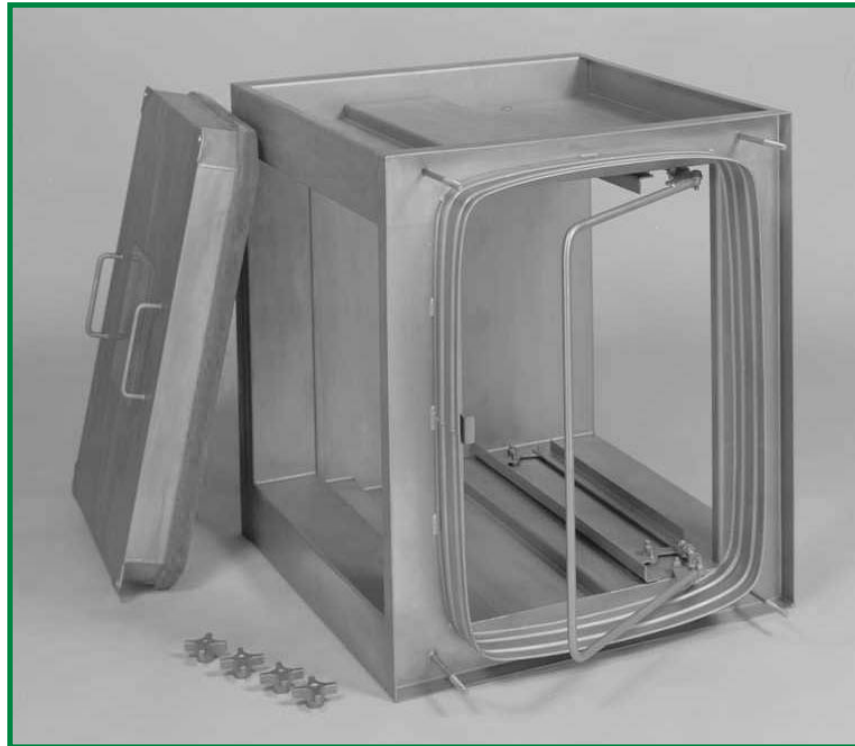

Installation, Operation and Maintenance Manual



Camfil	Installation, Operation & Maintenance Manual
FB Housing	3401i-0404
Camfil —clean air solutions	

Disclaimer

Before proceeding with any Bag-In/Bag-Out undertaking, review this Installation, Operation, and Maintenance Manual and all safety procedures with your company's safety personnel.

Camfil is committed to providing air filtration products, which meet or exceed our customer's expectations. We are dedicated to a corporate-wide policy of continual improvements as a means of insuring our leadership position in the air filtration marketplace.

The Camfil housings and filters are designed to protect personnel and the general public by filtering dangerous materials. The filters you change can be contaminated with these dangerous materials. In order for your complete protection and the protection of the general public, it is imperative you follow these instructions as amended by your safety personnel. The bagging method of changing a filter is not fail-safe, but it is the safest, pragmatic method available for changing a contaminated filter. Since all types of housing designs and configurations cannot be addressed by a single manual or set of safety procedures, we propose a proven method of replacing contaminated filters with clean filters. Once this method is understood by both maintenance personnel and safety personnel, they can adapt the most suitable method to use, based on the housing, location, type of filter/adsorber, and any other mitigating factor that can affect safety.

Carefully study this manual and your safety personnel's amendments so that you have the entire procedure in mind before initiating the change-out procedure. Before initiating this procedure, verify you have all the necessary tools on hand.

Camfil describes the "twist and tape" method and banding method of sealing the bag in the manual, but any method approved by your safety personnel is acceptable, including, but not limited to, thermal sealing of the bag.

Please note: In order to prevent the operator or immediate environment from contamination, use common sense, adhere to the instructions in this manual and consult your company's safety manual.

Table Of Contents

	<u>Page No.</u>
Introduction to Bag-In/Bag-Out Housings.....	4
Installation of Filtration Housing.....	6
Installation of New Filter(s) or Adsorber(s) Prior to New System Startup.....	6
Filter Change-Out (Replacing Contaminated Filter(s) or Adsorber(s).....	10
Filter Change-Out Overview.....	13
Maintenance	14
Locking Mechanism Adjustment.....	17
Spare Parts and Accessories.....	18

Introduction To Bag-In/Bag-Out Housings

Camfil's line of Bag-In/Bag-Out housings are "containment" design, side loading filter housing used for critical applications. These filter housings have been designed to meet the air filtration needs of industries and research facilities that handle dangerous or toxic, biological, radiological or carcinogenic materials. To minimize exposure to these harmful contaminants, while replacing and handling contaminated filters, the housing incorporates a heavy duty plastic bag covered access port. Once the initial filters are installed and the bag attached and secured, all filters, both new and contaminated are handled through the bag, using procedures described throughout this manual, hence the name "Bag-In/Bag-Out".

The filter-to-housing seal is accomplished with two filter locking mechanisms which forces the fluid seal channel of the filter against the housing knife-edge sealing surface, thereby making the knife-edge seal inside the fluid (gel) creating a positive airtight seal. The filter locking mechanism is operated from inside the housing and designed to prevent the access door from being installed without the locking mechanism properly secured. When the initial filters are installed or the contaminated filters are changed out, the system must be in-place leak tested to assure the filters are sealed properly and all contaminants will be filtered from the air stream.

Camfil's Bag-In/Bag-Out housing can be designed in an assortment of arrangements, depending on the user's requirements and the types of filters or adsorbers installed inside the housings. Camfil's Bag-In/Bag-Out housings come in various sizes. Sizes range from one half wide housings up to three wide housings. The housings can be supplied individually as small filtration systems or as several housing modules. These modules can be factory welded and stacked together to create a variety of larger filtration systems to meet the customer's needs. Regardless of the filter housing size you may have, the filter change-out procedure described in the manual will remain the same.

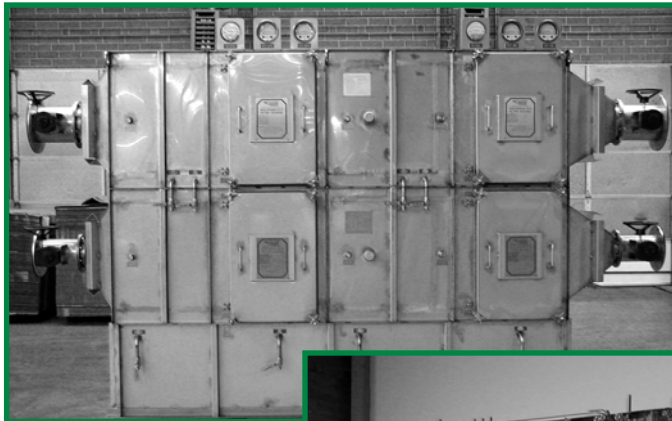

Filter Removal Rods

Camfil's Bag-In/Bag-Out multi-wide housings are equipped with filter removal rods for prefilters and final filters, to pull the second and/or third filters to the front access port of the housing. The removal rods are operated from inside the change-out bag using the glove sleeves. Camfil recommends removing the first filter by hand (without the use of the removal rod), to lighten the load that will have to be pulled by the removal rod. If the housing contains adsorbers it may be necessary on a three (3) wide housing, to remove the second adsorber by hand also, before using the removal rod to pull out the third adsorber.

Remove rod for prefilter.

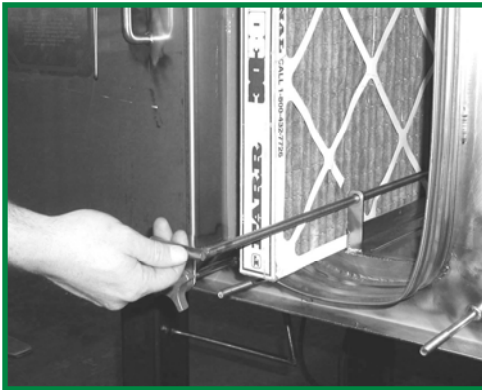

Remove rod for final



In-Place Test Section Housings

Camfil offers qualified In-Place Test Section housings to assist qualified testing technicians while performing In-Place Testing of filters or adsorbers. These test sections have proven to perform as good or better than the conventional method of in-place testing. Camfil has designed and qualified four (4) types of test sections (upstream, combination, downstream and accurate scan) for any need. The upstream test section housing design allows you to disperse a challenge agent uniformly across the filter/adsorber face so that the complete filter/adsorber is challenged. It also samples the concentration entering the downstream filter/adsorber. The combination test section provides the same function as the upstream test section, plus sampling the air stream for leaks, which have by-passed the upstream filter/adsorber. Downstream test sections sample the air stream for leaks, which have by-passed the upstream filter/adsorber. Camfil's "Accurate Scan" test housing is designed to scan the downstream face of a HEPA filter for leaks. The "Accurate Scan" test housing incorporates an access port protected by a heavy duty plastic bag, so all scan testing can be performed from outside the contaminated air stream. A probe is provided with guide rods to scan straight lines across the complete filter face and overlaps so that no part of the filter face will be missed when checking for leaks.

Users of "High Efficiency" filtration systems must commit to a testing program that will insure the installed filtration system will perform as intended from initial start-up, throughout the life of the filtration system. In some applications, guidelines for filter system testing may not be established by appropriate regulatory agencies or engineering societies. Whenever an organization has no established guidelines, often the standards for in-place testing of air filtration units for nuclear facilities is specified.

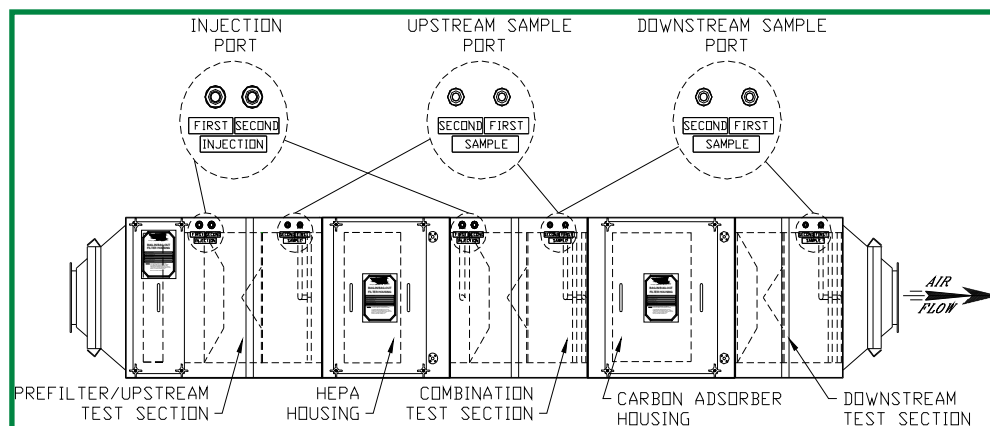

Installation Of Filtration Housing

1. Check filtration housing for loose items that may have been stored inside during shipment. Remove any loose items which are present. All loose items should be inventoried and stored in a controlled environment along with filter(s)/adsorber(s). These items should remain in the controlled environment, in their original boxes until installed.
2. To allow for filter(s) installation and change-out, a minimum of four (4) feet of clearance in front of access door(s) is recommended.
3. The filtration housing must be installed in the correct orientation. Be sure the direction of airflow and the position of the housing access door(s) is correct prior to installation of ductwork to filtration housing. To determine the direction of access, imagine that you are standing on the upstream end of the housing, with the airflow striking your back. If the door is on your left, the housing is left hand access. If the door is on your right, the housing is right hand access.
4. The ductwork should be permanently installed to the filtration housing and sealed to prevent leakage between the ductwork and filtration housing. All sections of the filtration system, including fans, dampers, etc. should be complete and ready for operation. The overall filtration system should be securely mounted to a curb, base, or structural support.
5. Following installation of the ductwork and filtration housing, the system should be cleaned to remove dust or debris before installing new filter(s)/adsorber(s) into the system.

Installation Of New Filter(s) or Adsorber(s) Prior To New System Start-Up

1. Check for correct model number, quantity, type, and size of media.
2. Unpack the filter/adsorber in accordance with Camfil's recommended instructions. Rest filter on floor and cut open taped seam with utility blade (set blade to 1/8" max.). Open box and bag(s) protecting filter/adsorber. Pull excess bag(s) over the edge of the box. Turn box over carefully holding flaps away from filter/adsorber, so filter/adsorber will rest on the floor. Lift box and bag(s) from filter/adsorber.
3. Take extreme caution when removing HEPA filters from their boxes. Handle only the exterior frame of the filter. Touching the filter face can damage the media, adversely affecting the filter's performance and efficiency.
4. Visually inspect the filter/adsorber frame and media for damage prior to installation.

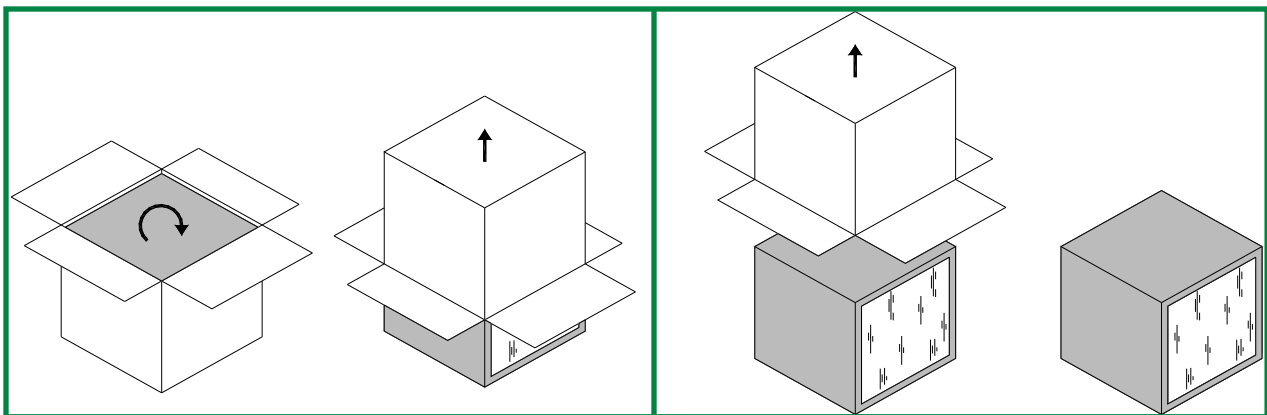

- Open filter/adsorber box.
- Turn box over.

- Filter/adsorber should rest on floor.
- Remove box and packaging..

5. To gain access to the inside of the filtration housing, remove the housing access doorknobs by turning counter-clockwise (for housings equipped with swivel latches: do not remove doorknobs; loosen and swivel door bolt out from door corner retainer). Pull the access door straight towards you to remove.
6. To install prefilter(s) (if required for the application), push the prefilter inside the housing using the slide track. Make sure to install prefilters with the pleats in the vertical position.
7. To install primary filter(s)/adsorber(s), release the locking mechanism handle from the handle latch. Slowly open the locking mechanism by pulling the handle fully open. Load the filter(s)/adsorber(s) into the housing with the fluid seal channel towards the housing knife-edge (opposite the locking mechanism). Make sure the filter/adsorber is correctly orientated when placing inside of the filtration housing. The filter clips should be positioned on the top and bottom of the filter (see pictures). The filter shall be installed with the pleats, or separators in the vertical position. Install adsorbers with the carbon beds in the horizontal position. Push the filter(s)/adsorber(s) to the back of the filtration housing until it stops. For filtration housings that contain more than one filter/adsorber, it may be necessary to push one filter as far inside the housing as possible. Next, install the second filter to help push the first filter to the back of the housing. When all the filter(s)/adsorber(s) are installed correctly in a multi-wide housing, the last filter/adsorber edge should be aligned with the sealing surface edge.

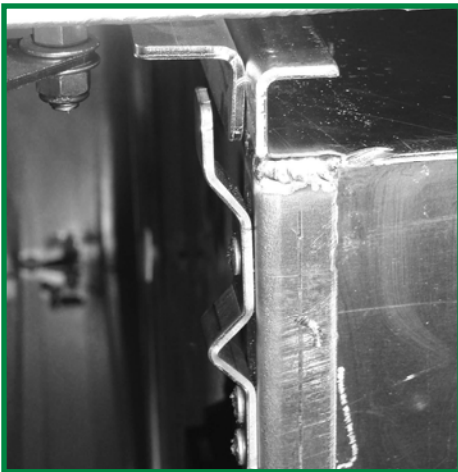
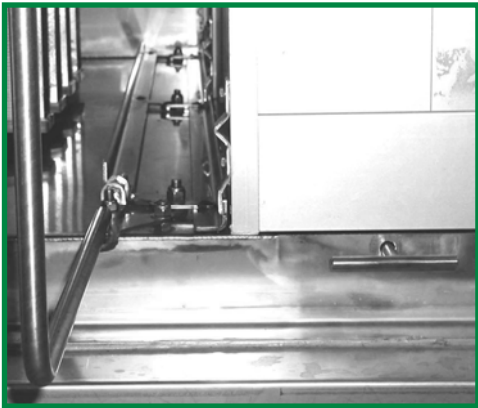

Correct filter installation, with locking tray angle between clip and filter frame

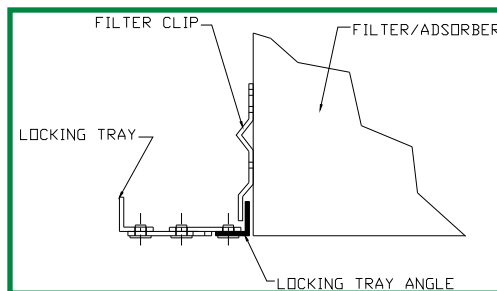

Incorrect filter installation, with locking tray angle outside clip and filter frame

8. Once the filter(s)/adsorber(s) is loaded inside the housing, slowly close the locking mechanism handle by pushing the locking mechanism handle towards the locking handle latch (see illustrations and pictures on this page and pictures on next page). This allows the fluid seal channel on the filter/adsorber to seal with the knife-edge sealing surface. Lock the locking mechanism handle with the handle latch.

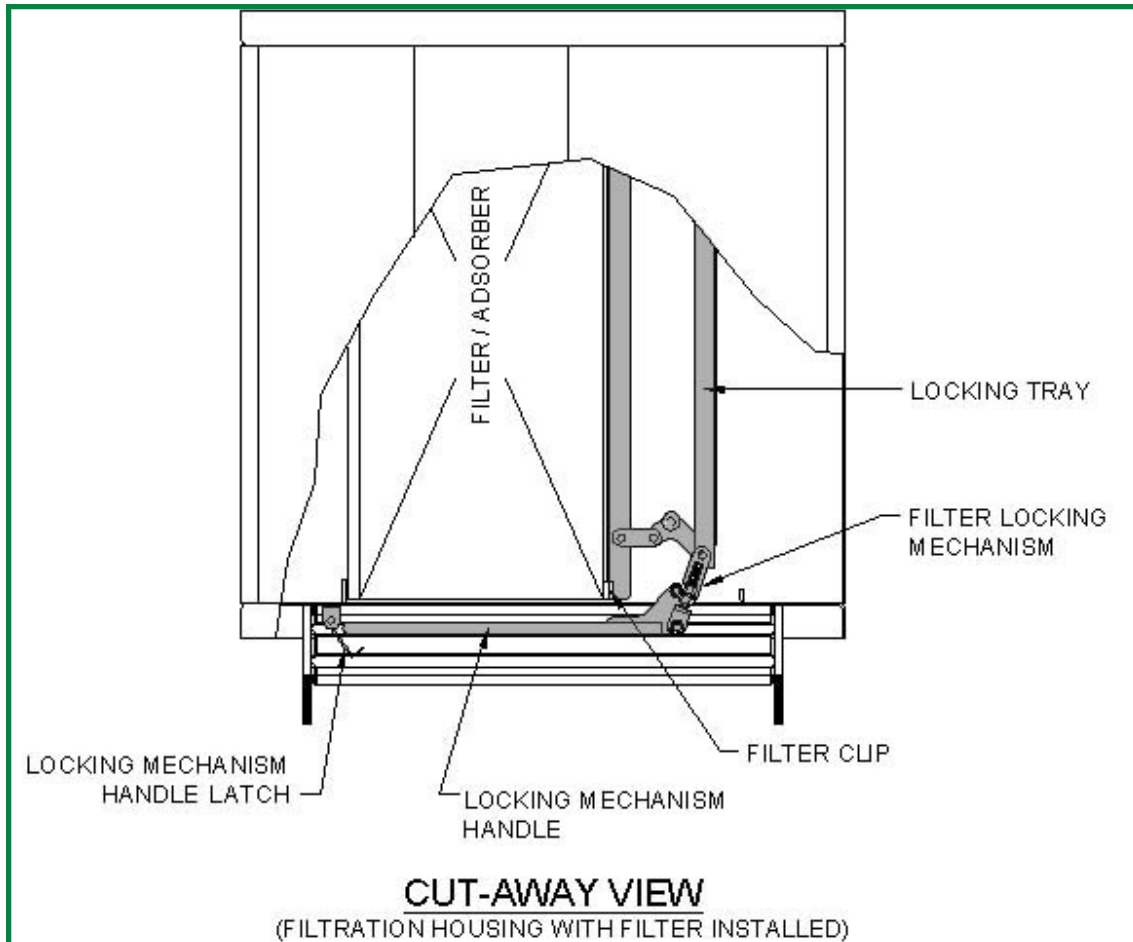

Slowly close the locking mechanism handle by pushing the handle towards the handle latch.





Locking handle should close fairly easily, until approximately 1" before the locking handle latch. Then moderate pressure should be applied to lock handle.

Warning: Do not force the locking handle to close. See page 17 if locking handle needs adjustment.



Lock the locking tray handle with the handle latch.

9. Install the plastic change-out bag(s) over the bagging ring(s). Check the door label to insure the correct change-out bag size is installed (see Spare Parts and Accessories page 18), each change-out bag has a tag with the bag size located on the shock cord, hemmed into the bag opening. The shock cord is to be located between the second raised rib of the bagging ring and the housing. The seam of the bag should be located at the top of the ring so the bag gloves are in the correct position. Once the change-out bag has been installed on the bagging ring, install the security strap around the change-out bag with the Velcro side out. The security strap is to be located between the first and second raised ribs of the bagging ring. Tighten the security strap and secure any excess strap so that it does not interfere with the door seal when the door is installed. After the change-out bag has been secured with the security strap, extend the bag out completely. Fold and roll the bag towards the housing, squeezing trapped air out of the folded/rolled portion of the bag until the bag is tucked neatly between the bagging ring and the filter access port. While holding the change-out bag in this position, replace the housing access door carefully. Tighten the doorknobs alternately by turning clockwise until door is sealed against the housing. The filtration system is now ready for operation.

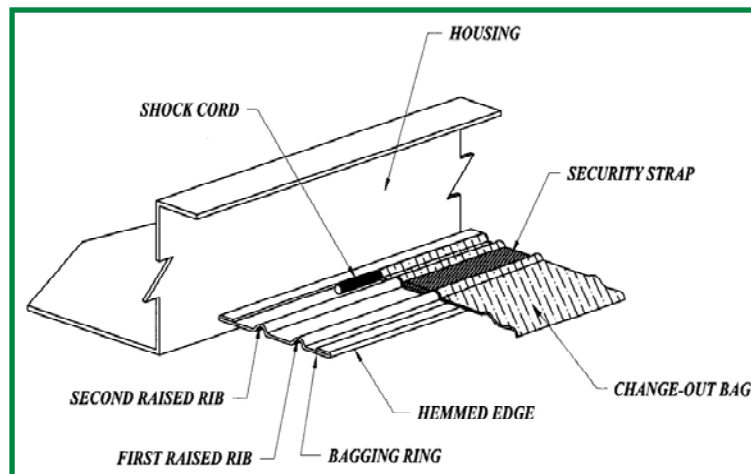

FILTER CHANGE-OUT

(Replacing Contaminated Filters Or Adsorbers)

Bag-In/Bag-Out Concept

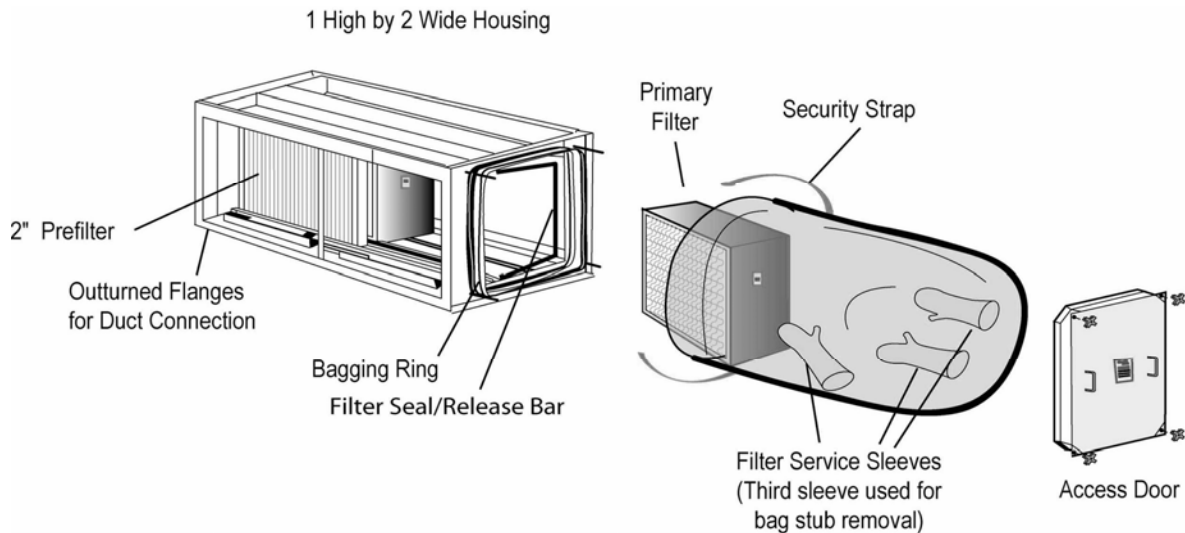

Consult your safety officer before beginning filter change-out, to assure all proper procedures are followed for your application.

Note: Filtration housings that contain more than one filter/adsorber are equipped with filter removal rods. Filtration housings containing multiple prefilters also are equipped with removal rods. The filter removal rod can be operated from inside the change-out bag to aid in removing the second or third filter/adsorber inside the housing. To operate the filter removal rod, grab the handle from inside the bag glove and pull filter/adsorber towards you. It is recommended on all multi-filter change-outs that the first filter/adsorber be removed by hand to lighten the load that will have to be pulled by the removal rod. Adsorbers are very heavy, and it may require a hard pull to remove them from the housing. For filtration housing containing three (3) adsorbers, it may be necessary to remove the second adsorber by reaching inside the filtration housing and pulling the adsorber out by hand.

1. Before replacing a contaminated filter(s)/adsorber(s), the airflow through the filtration system must be stopped. This can be performed by shutting-down the system, or bypassing the airflow through the system to another system, when applicable. To minimize possible contamination, close upstream and downstream dampers (if equipped). It is recommended that protective clothing, gloves, and respirators be worn when changing filters with dangerous contaminants. Consult your safety officer before beginning filter change-out to assure all proper procedures are followed for your application.
2. To gain access to the inside of the filtration housing, remove the housing access doorknobs by turning counter-clockwise (for housings equipped with swivel latches: do not remove doorknobs; loosen and swivel door bolt out from door corner retainer). Pull the access door straight towards you to remove.
3. To remove a prefilter, or header track filter, extend the change-out bag and follow steps 4 through 6. When removing filters or adsorbers sealed by a locking mechanism, extend the change-out bag and release the locking mechanism handle from the handle latch. Slowly open the locking mechanism by pulling the handle fully open, this will pull the filter away from the knife-edge sealing surface. Upon completion follow steps 4 through 6.

4. Use one change-out bag per filter/adsorber removed (multiple prefilters can be removed inside one change-out bag as long as the weight is approximately 25 lbs. or less). Carefully remove the filter from inside the filtration housing by inserting your arms into the change-out bag gloves and pulling the filter into the change-out bag. A Camfil change-out shelf can assist in making the change-out easier (as shown in picture, see Spare Parts and Accessories, page 18), or use a table to place filter after removing from housing. Inspect the sealing surface of the filtration housing to insure no foreign matter will interfere with the new filter to be installed. Remove arms from the change-out bag gloves, leaving gloves inside bag.



5. Once the filter/adsorber is removed from the housing into the change-out bag, tightly twist the change-out bag together between the filter access port and the contaminated filter. Tape or tie strap approximately 8" of the twisted bag to secure and cut in the middle of section. Tape over exposed edges where bag was cut. Remove the contaminated filter/adsorber for disposal. A banding kit can also be used (as shown in picture, see Spare Parts and Accessories, page 18). Remove the change-out bag security strap and gently position the bag's shock cord between the two raised ribs of the bagging ring. If the filtration system only has a single filter, proceed to step 7.



6. Install a new, empty change-out bag around the bagging ring (over top of the "stub" bag), and locate the shock cord between the second raised rib and the housing, with the seam of the bag located at the top of the bagging ring. Remove the "stub" bag (inside bag) from the bagging ring and pull to the bottom end of the change-out bag. Re-install security strap and carefully remove the next filter/adsorber from inside the filtration housing by inserting your arms into the change-out bag gloves, and pulling the filter into the change-out bag. Continue repeating steps 4 through 6 until all filters are removed from the filtration housing, using a new change-out bag for each filter/adsorber. When all filters are removed there should still be a "stub" bag remaining on the bagging ring.

7. Place a new change-out bag over a new filter/adsorber to be installed (see Installation of New Filter for proper unpackaging and preparations). Make sure the new filter/adsorber is orientated so that when placing inside of the filtration housing the filter clips will be on the top and bottom of the filter (see pictures, page 7). Carefully pull the shock cord of change-out bag to the bottom of the filter. Pull the remainder of the bag down until the filter is at back of the change-out bag. Turn the filter/adsorber over and pull the bag up. Install the new change-out bag with filter/adsorber around the bagging ring (over top of the "stub" bag), locating the shock cord between the second raised rib and the housing, with the seam of the bag located at the top of the bagging ring. Insert arm into change-out bag glove closest to housing and remove the "stub" bag from the bagging ring. Pull as much of the "stub" bag as possible into the glove while turning the glove "inside-out", use one of the other gloves to help push all the "stub" bag into the glove turned "inside-out". Reinstall the security strap and slide the new filter/adsorber into the filtration housing. Once the filter is installed into the housing, tightly twist the change-out bag together between the filter access port and the glove turned "inside-out". Tape or tie strap approximately 8" of the twisted bag to secure, and cut in the middle of section.



Tape over exposed edges where bag was cut, and remove the excess portion of the bag. A banding kit can also be used. Repeat this step until all filters are installed inside housing, using a new change-out bag for each new filter/adsorber installed. For filtration housings that contain more than one filter/adsorber, it may be necessary to push one filter as far inside the housing as possible, then install the second filter to help push the first filter to the back of the housing.

8. Once all filters/adsorbers are installed in the housing, secure the change-out bag with the security strap as described in "Installation of New Filter". If the housing has locking mechanisms for the filters, slowly close the locking mechanism handle by pushing the locking mechanism handle closed to allow the fluid seal channel on the filter/adsorber to seal with the knife-edge sealing surface. Lock the locking mechanism handle with the handle latch.
9. The "stub" bag inside the glove closest to the housing can be removed by twisting tightly together and taping or tie strapping, and cutting off (remember to tape over exposed portion). If the "stub bag" will not interfere with the access door seal, the "stub" bag can remain inside the new bag until the next filter change-out. After the change-out bag has been secured with the security strap, extend the bag out completely. Fold and roll the bag towards the housing, squeezing trapped air out of the folded/rolled portion of the bag until the bag is tucked neatly between the bagging ring and the filter access port. While holding the change-out bag in this position, replace the housing access door carefully. Tighten the doorknobs alternately by turning clockwise until door is sealed against the housing (see diagram on next page). The filtration system is now ready for operation. Open upstream and downstream dampers (if equipped) and restart the system, or redirect by-passed airflow through the system.

Filter Change-Out Overview:

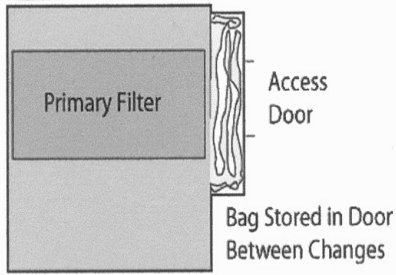

During operation the filter (s) are in place and the bag is stored in the door

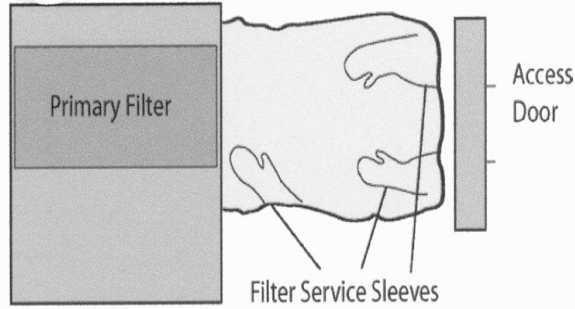

After removing the access door, extend the bag, and use the bag gloves to carefully move the contaminated filter into the bag.

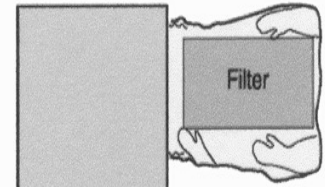

Remove the contaminated filter from the housing, supporting the filter on a table, or optional change-out tray.

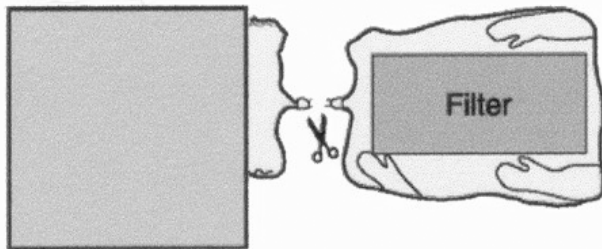

Seal the bag with banding ties between the filter and the door opening. Cut the bag with shears to contain the used filter.

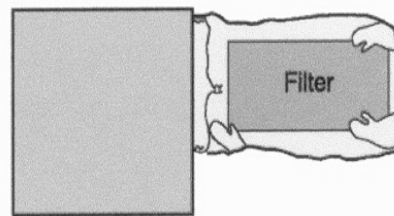

Place a new filter in a new bag and secure the new bag opening to the housing door opening. Move the old bag stub into the new bag cavity and install the filter.

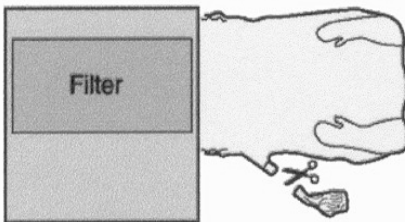

Move the old bag stub into the third service glove sleeve and seal the sleeve with banding ties between the bag body and the glove sleeve.

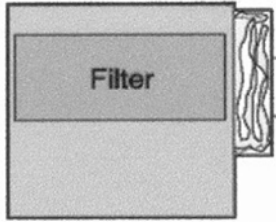

Carefully fold the bag and place in the door cavity. Replace door.

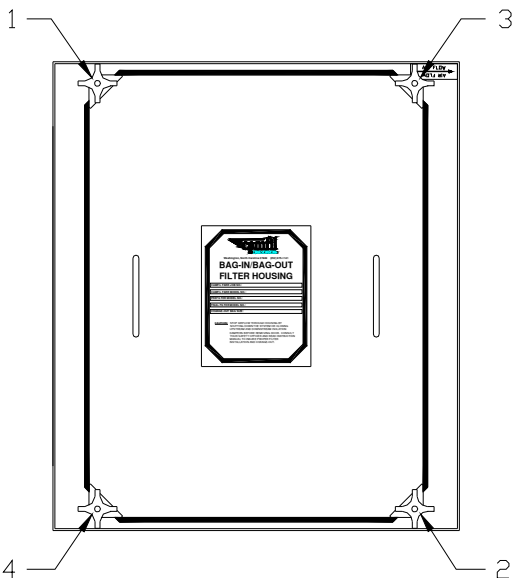
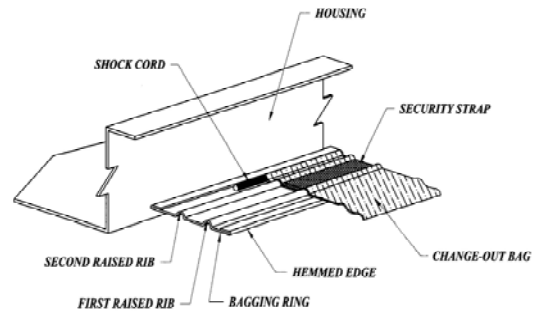

Access Doorknob Tightening Sequence

Doorknob Installation Ratchet Attachment can assist during tightening of doorknobs. To order from Camfil see Spare Parts and Accessories, page 18.

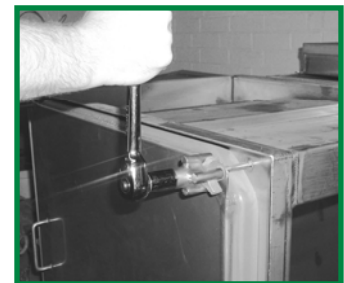

Maintenance

Important Note

Proper maintenance of the filtration housing is vital for proper operation. To maintain the desired level of filtration, it is necessary to perform filter(s)/adsorber(s) change-out when they are no longer functioning properly. To determine when media change-out is required, the following guidelines must be considered:

1. Components

For Particulate Filters (prefilters, HEPA filters):

- ◆ The pressure drop across the filter exceeds the recommended change-out pressure drop or system design pressure.
- ◆ The HEPA filter in-place leak test shows an unacceptable penetration of challenge aerosol.

For Carbon Adsorbers (HEGA):

- ◆ The in-place leak test shows an unacceptable penetration of challenge agent.

2. Filtration System

The filtration system is the containment structure built by Camfil. This structure may be a single housing, or a complete filter train (consisting of multiple, adjoining housings), depending on the scope of the contract. The filtration system is no longer functioning properly when any of the following occurs:

- ◆ A periodic site inspection, routine maintenance checks, or other planned surveillance testing reveals torn gaskets, broken welds, stripped threads on door bolts, or any other indication that the system's ability to contain the process airstream has been compromised.

To assure that the filtration system is maintained at peak performance, the owner must commit to periodic component maintenance, inspections/repairs, and test performed by qualified In-Place Testing personnel. These safe guards will insure containment has not been compromised, as well as a prompt and sufficient program outlining needed repairs.

Some components of the filtration system can be replaced, if damaged in service (see following pages for instructions). Access door gaskets can be removed and new gaskets installed and the locking mechanism front seal gasket can be replaced. Please call Camfil at 252-975-1141, with any comments or question regarding any equipment or procedures in this manual. Camfil will answer any questions regarding the systems and components we design and build.

Door Gasket Replacement

If the gasket on the access door becomes damaged, it can be replaced with new gasket by the user. You may purchase replacement gasket from Camfil (see Spare Parts and Accessories, page 18). The following steps should be taken to replace a door gasket:

1. Remove the door with the damaged gasket from the filtration housing. The filtration system will have to be shut down for removal, consult you safety personnel first.
2. **Warning: This step may require the use of sharp objects. Take extreme caution when performing this step.** With the door moved to a suitable work area, remove the damaged gasket from the door by cutting, tearing or pulling until all of the gasket is removed from the door. Scrape or cut off the remaining adhesive caulking from the door. Remove any remaining adhesive caulking, dirt, grease, with a clean wipe or cleaning solvent.
3. Position door so the hemmed edge is up and dry fit the new gasket to the door just like previous gasket was installed, and cut gasket to length. Allow for 3/4" overlap when cutting, this is to compress the gasket edges back together when performing the final installation. It is important to cut gasket as straight as possible.
4. Locate adhesive caulking (DC 732 or equal) and caulking gun. Cut tip off adhesive tube so that a bead of caulking approximately 1/8" to 3/16" diameter will be produced. Deposit a continuous bead of caulking (1/8" to 3/16" diameter) inside the bottom of the extruded gasket channel.
5. Start placing gasket on door so that the hemmed edge of door will lay inside the bottom of the extruded gasket channel (refer to illustration). With one hand, use your thumb and index finger to gently pinch the extruded gasket together while placing the gasket with the other hand until the entire door is covered. Apply an even layer of caulking over the face area of the cut ends (do not apply to thick). Install ends together over door while compressing gasket. Apply a very thin layer of caulking around the outside edge of the joint.
6. Check the alignment of the gasket and reposition gasket if needed while caulking in pliable. Gently lift and turn door over on table with the gasket face down. Apply caulking around the perimeter where the top edge of the gasket meets the door. The adhesive caulking generally takes 24 hours to fully cure.
7. After the adhesive caulking fully cures, the door can be reinstalled on the housing.

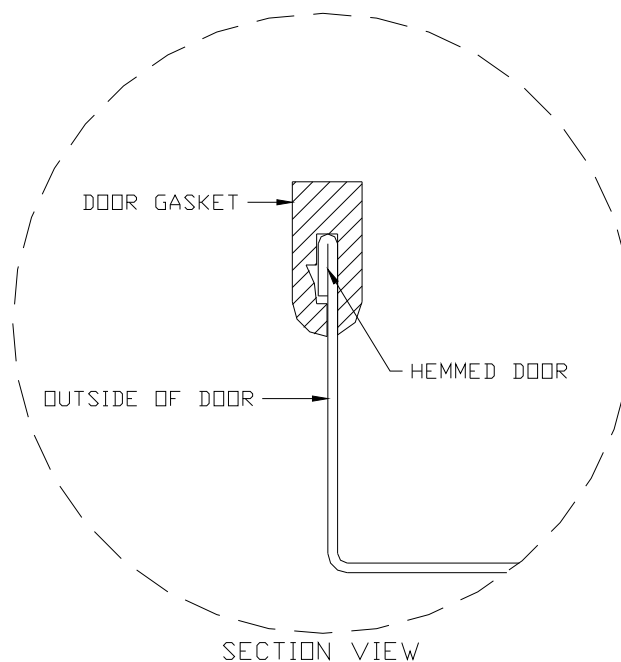

Removable Fluid Seal Locking Mechanism

Camfil Fluid Seal housings are equipped with removable locking mechanisms. Under extreme working environments, it could be possible for the locking mechanism to deteriorate and need replacement. If your housing has been in service for an extended period of time and the locking trays are suspect to be deteriorated or damaged, contact Camfil for replacement locking mechanisms. The following steps should be taken to replace a fluid seal locking mechanism. To have a understanding of the various parts of the locking mechanism, study detail illustrations No. 1 and No. 2 (next page) before replacing locking mechanism.

1. Consult your company's safety personnel before replacing any part which has been in service. Camfil is not responsible for any personnel or procedures which include accessing a filtration housing that has been put into service.
2. Remove the access door to gain access to the inside of the filtration housing.
3. There are two locking mechanisms installed in each filtration housing (top and bottom). Take caution when removing the top locking mechanism, so that the locking mechanism does not fall. This could damage the housing or injure the personnel working on the locking mechanism. Measure the distance which the 3/8" locknuts are positioned on the locking mechanism adjustment (refer to Detail No. 2 on next page), this dimension will be used when replacing the new locking mechanism. Remove two (2) 3/8" locknuts from backside of adjustment studs connected to pivot arms and linkage tabs (one on top, one on bottom). Remove two (2) 5/16" locknuts from the pivot arms (one on top, one on bottom), which is connected to the housing with 5/16" studs. Remove the locking handle from the locking mechanism assembly and filtration housing. Remove 3/8" locknuts from locking trays, all nuts must be removed before locking mechanism can be removed from housing (save all locknuts for replacement installation).
4. Remove the locking mechanisms from the filtration housing. **(Note: There is a nylon flat washer around each 3/8" stud between the locking mechanism and filtration housing. These nylon flat washers should remain around 3/8" studs, but could fall from the top studs when the locking mechanisms are removed. Be sure the nylon washers are around studs, before replacing new locking mechanism)**

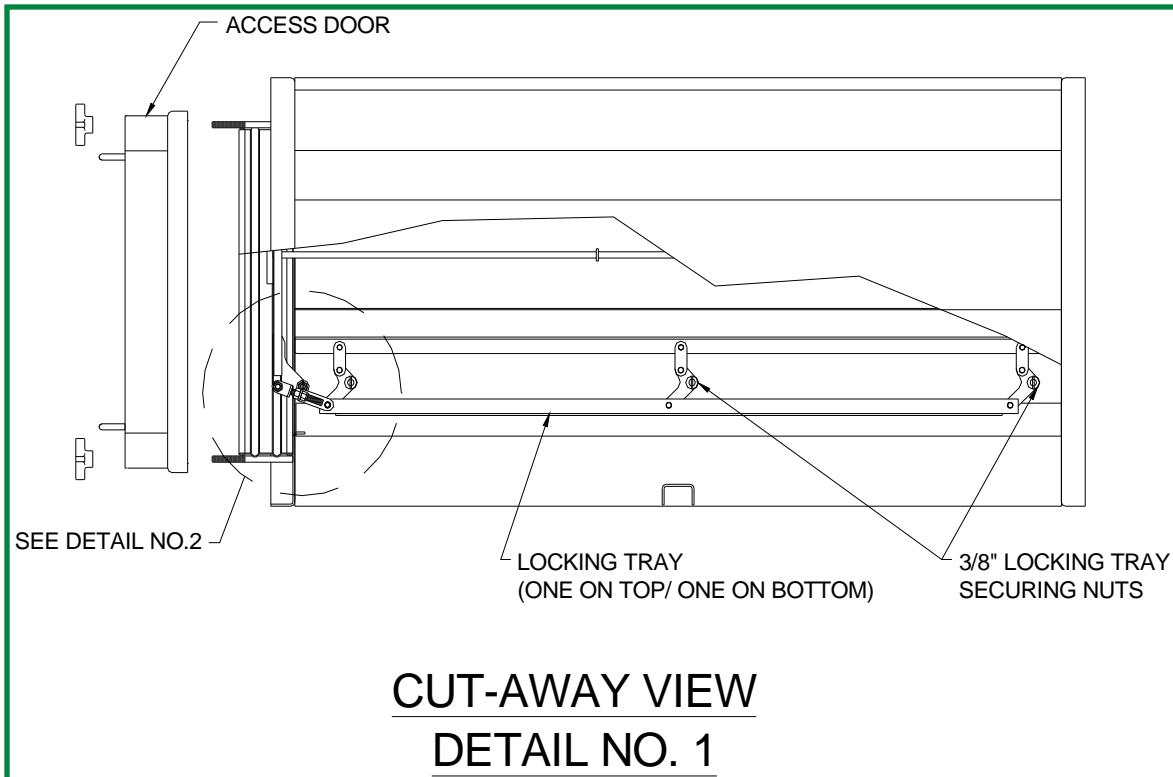

- Install replacement locking mechanisms and secure with 3/8" locknuts which were removed from replaced locking mechanism. **Note: Before replacing new locking mechanism, be sure the nylon washers are around studs.** Tighten 3/8" locknuts securing locking trays to housing, then loosen the locknuts 1/4 turn (**This step is critical to allow free movement of the locking tray**). Install locking handle by sliding adjustment studs through linkage tabs, and pivot arms through 5/16" studs connected to housing. Tighten 5/16" locknuts on pivot arms, then loosen 1/4 turn (**This step is critical to allow free movement of the locking handle**).
- Using the dimension that was recorded in step 3, tighten 3/8" locknuts on adjustment studs. This may require adjusting the inside 3/8" nut to the correct dimension also. To assure there is free movement of both locking trays, open and close locking mechanism several times with the locking handle (push to close, pull to open).

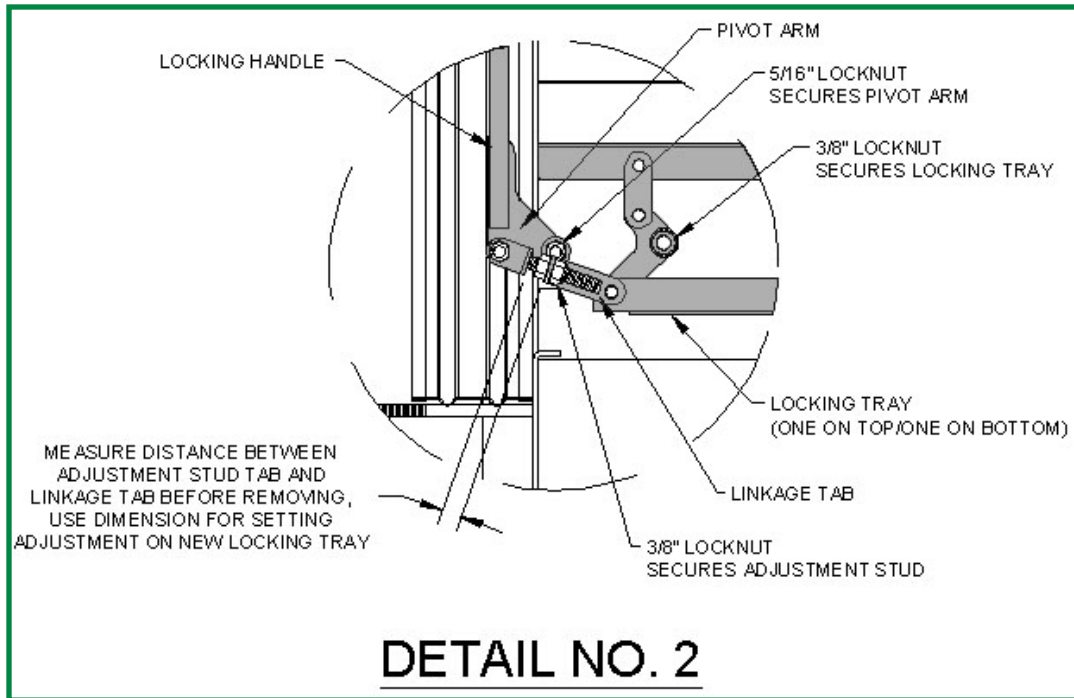

Locking Mechanism Adjustment

- When installing filter(s)/adsorber(s) and/or closing the locking mechanism, do not force the handle closed. The locking mechanisms are preset at the factory (when installed in a filtration system from the factory) with the correct tension on the locking handle. The handle should move fairly easily until within approximately 1" of the locking handle latch, then moderate pressure should be applied to latch and secure the handle. If the handle takes more than moderate pressure to latch, the locking mechanism adjustment should be corrected for the proper tension.
- Excessive tension:** To adjust the tension of the locking handle, locate the 3/8" locknuts on the adjustment studs (one on top, one on bottom), refer to Detail No. 2. If there is excessive tension on the locking mechanism handle, adjust the 3/8" locking nuts by turning counter-clockwise until the proper tension is achieved. Tighten the inside nuts back up to the locknuts.
- Insufficient tension:** To adjust the tension of the locking handle, locate the 3/8" locknuts on the adjustment studs (one on top, one on bottom), refer to Detail No. 2. If there is insufficient tension on the locking mechanism handle, loosen the inside nuts and adjust the 3/8" locking nuts by turning clockwise until the proper tension is achieved. Tighten the 3/8" locknuts back to the inside nuts.

Spare Parts and Accessories

When placing an order for replacement parts, please provide Camfil with the original job order number and housing model number. This information can be found on the access door label, like the one pictured below.

- Camfil Job Number →
- Camfil Housing Model Number →
- Prefilter Model Number (If Applicable) →
- Final Filter Model Number →
- Change-Out Bag Size →



Camfil offers additional parts and accessories which can be used for repairing door gaskets, or assisting in the Filter Change-Out.

Door Gasket.....Camfil Part Number: M32001001
 (order by the foot, to determine length need, measure circumference of door which the gasket is to be replaced, and add one foot extra, carry to next highest foot length)

Doorknobs.....Camfil Part Number: M36001000

Change-Out Shelf.....Camfil Part Number: Contact Camfil

Banding Kit.....Camfil Part Number: M34001023

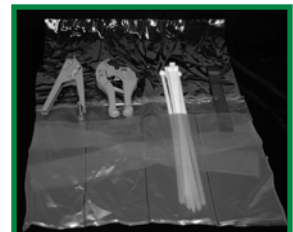

Doorknob Installation
 Ratchet Attachment.....Camfil Part Number: M60000471





200 Creekside Drive
Washington, North Carolina, USA 27889
Phone: (252) 975-1141
Fax: (252) 975-1041
Email: Sales-WA@camfil.com

North American Manufacturing Locations

Jonesboro, Arkansas • Riverdale, New Jersey • Corcoran, California • Delano, California • Crystal Lake, Illinois
Holly Springs, Mississippi • Laval, Quebec • Conover, North Carolina • Washington, North Carolina • Concord, Ontario

World Wide Manufacturing Locations

Belgium • France • Germany • Ireland • Malaysia • Sweden • Switzerland • United Kingdom

Camfil, Inc.

United States Tel: (973) 616-7300 Fax: (973) 616-7771

Canada Tel: (450) 629-3030 Fax: (450) 662-6035

Camfil has a policy of continuous research, development and product improvement. We reserve the right to change designs and specifications without notice.

Represented by:



Magnehelic® Differential Pressure Gage

OPERATING INSTRUCTIONS



SPECIFICATIONS

Dimensions: 4-3/4" dia. x 2-3/16" deep.

Weight: 1 lb. 2 oz.

Finished: Baked dark gray enamel.

Connections: 1/8" NPT high and low pressure taps, duplicated, one pair side and one pair back.

Accuracy: Plus or minus 2% of full scale, at 70°F. (Model 2000-0, 3%; 2000-00, 4%).

Pressure Rating: 15 PSI (0,35 bar)

Ambient Temperature Range: 20° to 140°F (-7 to 60°C).

Standard gage accessories include two 1/8" NPT plugs for duplicate pressure taps, two 1/8" NPT pipe thread to rubber tubing adapters, and three flush mounting adapters with screws.

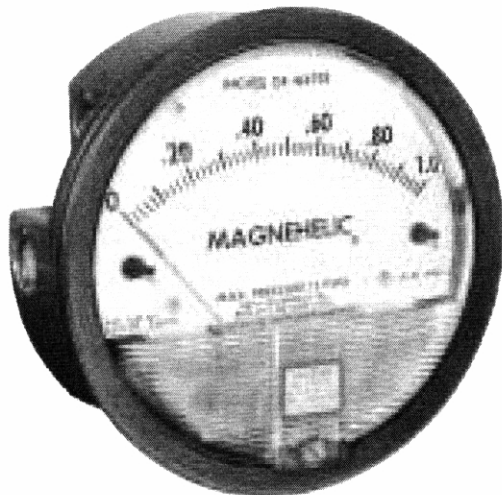

Caution: For use with air or compatible gases only.

For repeated over-ranging or high cycle rates, contact factory.

Not for use with Hydrogen gas. Dangerous reactions will occur.

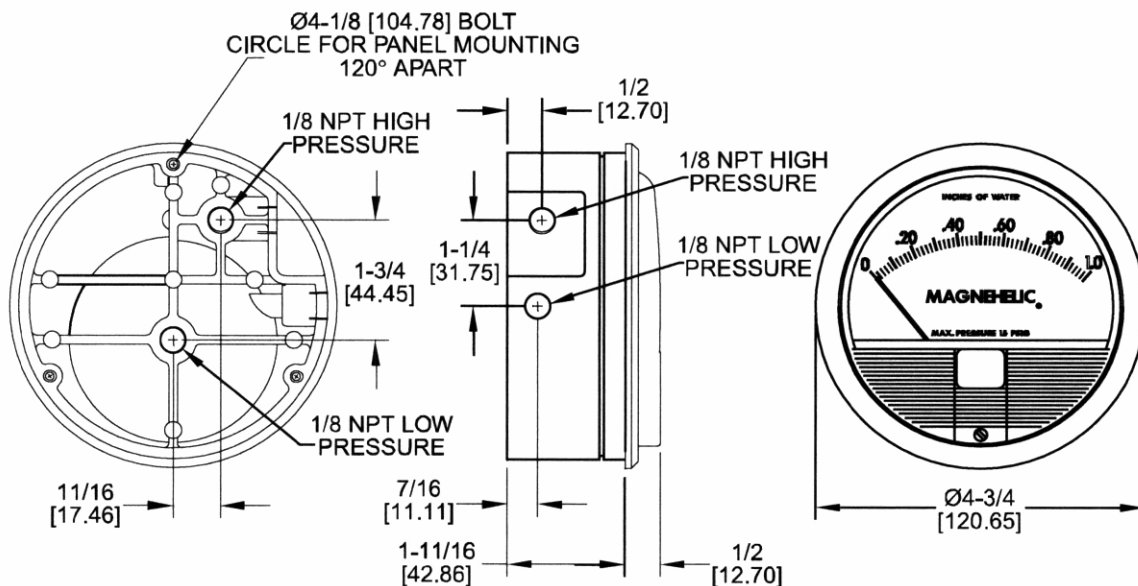

MAGNEHELIC® INSTALLATION

1. Select a location free from excessive vibration and where the ambient temperature will not exceed 140°F. Also, avoid direct sunlight which accelerates discoloration of the clear plastic cover. Sensing lines may be run any necessary distance. Long tubing lengths will not affect accuracy but will increase response time slightly. Do not restrict lines. If pulsating pressures or vibration cause excessive pointer oscillation, consult the factory for ways to provide additional damping.

2. All standard Magnehelic gages are calibrated with the diaphragm vertical and should be used in that position for maximum accuracy. If gages are to be used in other than vertical position, this should be specified on the order. Many higher range gages will perform within tolerance in other positions with only rezeroing. Low range Model 2000-00 and metric equivalents must be used in the vertical position only.

3. Surface Mounting

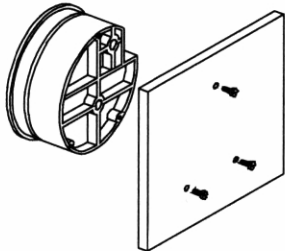

Locate mounting holes, 120° apart on a 4-1/8" dia. circle. Use No. 6-32 machine screws of appropriate length.

4. Flush Mounting

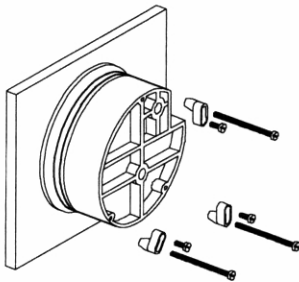

Provide a 4-9/16" dia. opening in panel. Insert gage and secure in place with No. 6-32 machine screws of appropriate length, with adapters, firmly secured in place. To mount gage on 1-1/4"-2" pipe, order optional A-610 pipe mounting kit.

5. To zero the gage after installation

Set the indicating pointer exactly on the zero mark, using the external zero adjust screw on the cover at the bottom. Note that the zero check or adjustment can only be made with the high and low pressure taps both open to atmosphere.

Operation

Positive Pressure: Connect tubing from source of pressure to either of the two high pressure ports. Plug the port not used. Vent one or both low pressure ports to atmosphere.

Negative Pressure: Connect tubing from source of vacuum or negative pressure to either of the two low pressure ports. Plug the port not used. Vent one or both high pressure ports to atmosphere.

Differential Pressure: Connect tubing from the greater of two pressure sources to either high pressure port and the lower to either low pressure port. Plug both unused ports.

When one side of the gage is vented in dirty, dusty atmosphere, we suggest an A-331 Filter Vent Plug be installed in the open port to keep inside of gage clean.

A. For portable use of temporary installation use 1/8" pipe thread to rubber tubing adapter and connect to source of pressure with rubber or Tygon tubing.

B. For permanent installation, 1/4" O.D., or larger, copper or aluminum tubing is recommended. See accessory bulletin S-101 for fittings.

Ordering Instructions:

When corresponding with the factory regarding Magnehelic® gage problems, be sure to include model number, pressure range, and any special options. Field repair is not recommended; contact the factory for repair service.

MAINTENANCE

Maintenance: No lubrication or periodic servicing is required. Keep case exterior and cover clean. Occasionally disconnect pressure lines to vent both sides of gage to atmosphere and re-zero. Optional vent valves, (bulletin S-101), should be used in permanent installations.

Calibration Check: Select a second gage or manometer of known accuracy and in an appropriate range. Using short lengths of rubber or vinyl tubing, connect the high pressure side of the Magnehelic gage and the test gage to two legs of a tee. Very slowly apply pressure through the third leg. Allow a few seconds for pressure to equalize, fluid to drain, etc., and compare readings. If accuracy unacceptable, gage may be returned to factory for recalibration. To calibrate in the field, use the following procedure.

Calibration:

1. With gage case, held firmly, loosen bezel, by turning counterclockwise. To avoid damage, a canvas strap wrench or similar tool should be used.
2. Lift out plastic cover and "O" ring.
3. Remove scale screws and scale assembly. Be careful not to damage pointer.
4. The calibration is changed by moving the clamp. Loosen the clamp screw(s) and move slightly toward the helix if gage is reading high, and away if reading low. Tighten clamp screw and install scale assembly.
5. Place cover and O-ring in position. Make sure the hex shaft on inside of cover is properly engaged in zero adjust screw.
6. Secure cover in place by screwing bezel down snug. Note that the area under the cover is pressurized in operation and therefore gage will leak if not properly tightened.
7. Zero gage and compare to test instrument. Make further adjustments as necessary.

Caution: If bezel binds when installing, lubricate threads sparingly with light oil or molybdenum disulphide compound.

Warning: Attempted field repair may void your warranty. Recalibration or repair by the user is not recommended. For best results, return gage to the factory. Ship prepaid to:

Dwyer Instruments, Inc.

Attn: Repair Dept.

102 Indiana Highway 212

Michigan City, IN 46360

Trouble Shooting Tips:

•*Gage won't indicate or is sluggish.*

1. Duplicate pressure port not plugged.
2. Diaphragm ruptured due to overpressure.
3. Fittings or sensing lines blocked, pinched, or leaking.
4. Cover loose or "O"ring damaged, missing.
5. Pressure sensor, (static tips, Pitot tube, etc.) improperly located.
6. Ambient temperature too low. For operation below 20°F, order gage with low temperature, (LT) option.

•*Pointer stuck-gage can't be zeroed.*

1. Scale touching pointer.
2. Spring/magnet assembly shifted and touching helix.

3. Metallic particles clinging to magnet and interfering with helix movement.

4. Cover zero adjust shaft broken or not properly engaged in adjusting screw.

We generally recommend that gages needing repair be returned to the factory. Parts used in various sub-assemblies vary from one range of gage to another, and use of incorrect components may cause improper operation. After receipt and inspection, we will be happy to quote repair costs before proceeding.

Consult factory for assistance on unusual applications or conditions.

Use with air or compatible gases only.

MAINTENANCE

Maintenance: No lubrication or periodic servicing is required. Keep case exterior and cover clean. Occasionally disconnect pressure lines to vent both sides of gage to atmosphere and re-zero. Optional vent valves, (bulletin S-101), should be used in permanent installations.

Calibration Check: Select a second gage or manometer of known accuracy and in an appropriate range. Using short lengths of rubber or vinyl tubing, connect the high pressure side of the Magnehelic gage and the test gage to two legs of a tee. Very slowly apply pressure through the third leg. Allow a few seconds for pressure to equalize, fluid to drain, etc., and compare readings. If accuracy unacceptable, gage may be returned to factory for recalibration. To calibrate in the field, use the following procedure.

Calibration:

1. With gage case, held firmly, loosen bezel, by turning counterclockwise. To avoid damage, a canvas strap wrench or similar tool should be used.
2. Lift out plastic cover and "O" ring.
3. Remove scale screws and scale assembly. Be careful not to damage pointer.
4. The calibration is changed by moving the clamp. Loosen the clamp screw(s) and move slightly toward the helix if gage is reading high, and away if reading low. Tighten clamp screw and install scale assembly.
5. Place cover and O-ring in position. Make sure the hex shaft on inside of cover is properly engaged in zero adjust screw.
6. Secure cover in place by screwing bezel down snug. Note that the area under the cover is pressurized in operation and therefore gage will leak if not properly tightened.
7. Zero gage and compare to test instrument. Make further adjustments as necessary.

Caution: If bezel binds when installing, lubricate threads sparingly with light oil or molybdenum disulphide compound.

Warning: Attempted field repair may void your warranty. Recalibration or repair by the user is not recommended. For best results, return gage to the factory. Ship prepaid to:

Dwyer Instruments, Inc.

Attn: Repair Dept.

102 Indiana Highway 212

Michigan City, IN 46360

Trouble Shooting Tips:

•*Gage won't indicate or is sluggish.*

1. Duplicate pressure port not plugged.
2. Diaphragm ruptured due to overpressure.
3. Fittings or sensing lines blocked, pinched, or leaking.
4. Cover loose or "O"ring damaged, missing.
5. Pressure sensor, (static tips, Pitot tube, etc.) improperly located.
6. Ambient temperature too low. For operation below 20°F, order gage with low temperature, (LT) option.

•*Pointer stuck-gage can't be zeroed.*

1. Scale touching pointer.
2. Spring/magnet assembly shifted and touching helix.

3. Metallic particles clinging to magnet and interfering with helix movement.

4. Cover zero adjust shaft broken or not properly engaged in adjusting screw.

We generally recommend that gages needing repair be returned to the factory. Parts used in various sub-assemblies vary from one range of gage to another, and use of incorrect components may cause improper operation. After receipt and inspection, we will be happy to quote repair costs before proceeding.

Consult factory for assistance on unusual applications or conditions.

Use with air or compatible gases only.



Farr 30/30[®]

High-Capacity MERV 8 Pleated Panel Filter

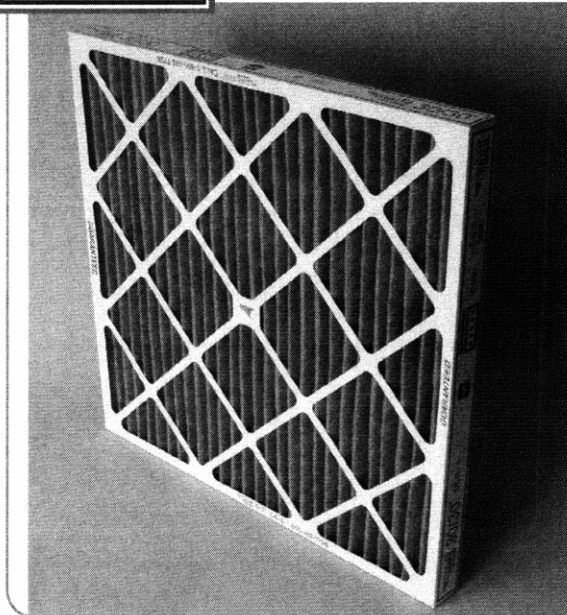

The Camfil Farr 30/30 has set the industry standard for pleated panel filters since 1963. With over 45 design enhancements, it continues to provide the industry's best value for medium efficiency filtration.

Setting the standard by which other pleated filters are judged, modern media manufacturing techniques and proprietary technological advancements ensure that the 30/30 is:

- Guaranteed to perform at the rated efficiency, or better, throughout the life of the filter.
- Guaranteed to last longer than any other pleated panel filter available.



Performing at MERV 8, using a mechanical particle capture principle, the 30/30 will not drop in efficiency while in service as will other pleated panel filters that incorporate an electret charge to obtain a MERV 8 value.

Its radial pleat design provides the longest life and lowest average pressure drop reducing the number of filter changes so your facility will use less fan power to move air through the filter.

The high wet-strength beverage frame and welded wire media backing provide structural integrity in any type of HVAC application virtually eliminating the additional costs associated with filter bypass or filter failure.

Available in 1", 2" or 4" deep configurations, the 30/30 is ideal for commercial, industrial, institutional or any other application where the ultimate level of protection of equipment and indoor air quality is a concern.

The 30/30 has an Energy Cost Index (ECI) of five stars, the highest performance rating available.

The best performing pleated panel filter — guaranteed!

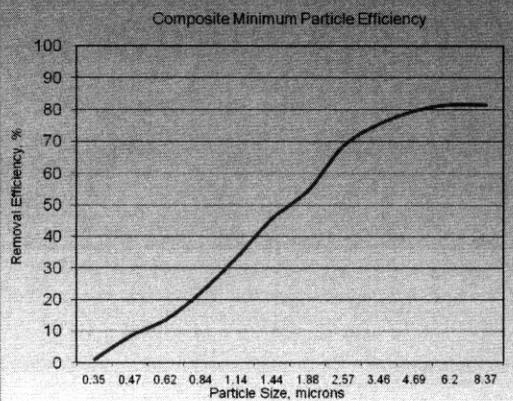

Composite minimum efficiency values of the 30/30 when evaluated per ASHRAE Standard 52.2-2007. The 30/30 has a MERV of 8 and MERV-A of 8 when tested per appendix J.

¹ A 5-Star rating indicates that this filter performs in the top 20% of all products of similar construction in the HVAC industry. Factors of consideration include maintained efficiency, energy usage and resistance to air flow. Detailed evaluation information is available from your Camfil sales outlet or on the web at www.camfilfarr.com.

Camfil Farr 30/30®

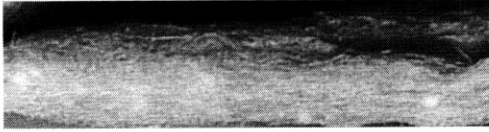

The highest media weight, more than any other pleated panel filter, and uniform lofting for high dust holding capacity, ensure that the 30/30 will last longer in any HVAC application.

Exclusive MERV 8 Performance from Camfil Media

The 30/30 media is manufactured from a proprietary blend of fibers that incorporate a mechanical principle of particle capture. The filter does not require an electret charge which would dissipate and reduce filter's efficiency after minimal hours of operation in a system. The media is lofted to a uniform depth to enhance the depth-loading characteristic and ensure the longest life of any pleated filter available. The high-loft also offers a lower resistance to airflow so fan horsepower required to move air through the filter is minimized. Camfil evaluates the quality of all incoming raw materials to maintain product integrity as part of a rigorous quality control program.

Welded Wire Grid Maintains Radial Pleat Design

The media is formed into a radial pleat for uniform dust loading and full use of the media area. V-style pleats blind while loading preventing full utilization of the media area and increasing the filters pressure drop resulting in increased energy usage. A welded wire grid, spot welded on one-inch centers maintains each radial pleat and maintains media stability through varying airflows.

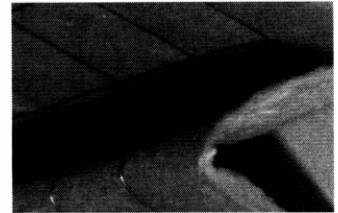

Rounded radial pleats, instead of v-shape pleats, allow full usage of media area.

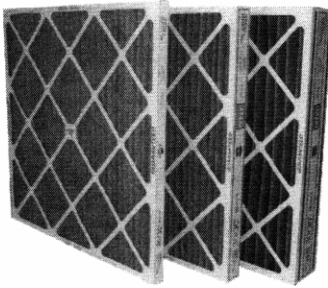

High Wet-Strength Beverage Board Frame

The high wet-strength beverage board frame, the thickest board in the industry, creates a stable and non-yielding media pack. Filter bypass is virtually eliminated because the filter fits securely in the filter holding mechanism. The media is bonded to the frame ensuring that all of the air seen by the filter will be treated by the filter. Diagonal support members are bonded to each pleat to maintain pleat spacing and add stability to the pack through bridge-style engineering. The 30/30 is guaranteed to 2.0" w.g. of pressure filter without failure. Costly filter blowouts and compromising of HVAC system cleanliness is eliminated.

Diagonal support members, glued to each pleat at its apex, helps maintain pleat stability and filter rigidity.



ISO 9001:2008 Certified Quality Control

Every 30/30 filter is identified on the frame with a unique manufacturing code that allows us to analyze every component of construction from raw materials to the point where the product is boxed for shipping. Filters are inspected for structural integrity so they are capable of operating in the harshest HVAC system conditions. The adhesiveness of diagonal support members to pleat apexes is inspected so pleat spacing is uniform to provide longer filter life. Each media lot is laboratory tested to confirm consistent performance and individual filters are submitted from each manufacturing facility on a strict schedule for ASHRAE 52.2 testing in our world-class testing facility.

The standard of the industry, by Camfil.

Used in many systems as a prefilter, the 30/30 extends the life of final filters by capturing larger contaminant and thereby allowing the final filters to concentrate on removing smaller particles such as those that are respirable and can cause lung damage. The 30/30 is also an excellent choice when applied as the only filter in a system to keep coils clean and maintain efficiency, and protect building occupants from contaminants of annoyance such as pollen, plant spores, atmospheric dusts and other indoor air irritants.



Unprecedented Industry Guarantee

If our filters don't outlast and outperform your current filters, we'll replace them, FREE. For guarantee details and a distributor list, visit www.camfil.com.

PERFORMANCE DATA

2" Deep Filter (actual filter depth 1.75")

Part Number	Nominal Depth (inches)	Nominal Size (inches)	Actual Size (inches)			Initial Resistance (inches w.g.)	Airflow Capacity (cfm)	Total Media Area (sq. ft.)	Pleats per Linear Foot
			Depth	Height	Width				
049880-019	2	16 x 16	1.75	15.50	15.50	0.31	890	7.8	15 pleats per linear foot
049880-008		20 x 10		19.50	9.50		700	6.0	
049880-009		20 x 14		19.50	13.50		975	8.3	
049880-007		20 x 12		19.50	11.88		835	7.4	
049880-011		20 x 15		19.50	14.50		1045	9.3	
049880-001		20 x 16		19.50	15.50		1100	9.9	
049880-013		20 x 18		19.50	17.50		1250	10.8	
049880-002		20 x 20		19.50	19.50		1390	11.9	
402271-007		20 x 30		19.50	29.50		2085	18.2	
049880-006		24 x 12		23.38	11.38		1000	8.4	
049880-015		24 x 18		23.50	17.50		1500	13.0	
049880-012		24 x 20		23.50	19.50		1670	14.3	
4 → 049880-005		24 x 24		23.38	23.38		2000	17.3	
049880-010		25 x 14		24.50	13.50		1220	10.4	
049880-020		25 x 15		24.50	14.50		1300	11.6	
049880-016		24 x 16		24.50	15.50		1335	11.8	
049880-004		25 x 16		24.50	15.50		1390	12.4	
049880-014		25 x 18		24.50	17.50		1565	13.5	
049880-003		25 x 20		24.50	19.50		1740	14.9	
049880-018		25 x 25		24.50	24.50		2170	19	

1" Deep Filter (actual filter depth 0.88")

Part Number	Nominal Depth (Inches)	Nominal Size (inches)	Actual Size (inches)			Initial Resistance (inches w.g.)	Airflow Capacity (cfm)	Total Media Area (sq. ft.)	Pleats per Linear Foot
			Depth	Height	Width				
404207-003	1	10 x 10	0.88	9.50	9.50	0.23	240	1.6	16 pleats per linear foot
054862-025		12 x 12		11.50	11.50		350	2.5	
404207-005		16 x 12		15.50	11.50		470	3.3	
054862-012		16 x 16		15.50	15.50		620	4.3	
054862-009		20 x 7		19.50	6.50		340	2.4	
054862-016		20 x 10		19.50	9.50		490	3.3	
054862-019		20 x 12		19.50	11.50		580	4.1	
054862-006		20 x 14		19.50	13.50		680	4.6	
054862-008		20 x 15		19.50	14.50		730	5.1	
054862-001		20 x 16		19.50	15.50		780	5.4	
054862-020		20 x 18		19.50	17.50		880	6.1	
054862-002		20 x 20		19.50	19.50		970	6.6	
054862-021		22 x 22		21.50	21.50		1180	8.2	
054862-022		24 x 10		23.50	9.50		580	4.0	
054862-010		24 x 12		23.50	11.50		700	4.9	
404207-004		24 x 14		23.50	13.50		820	5.5	
054862-015		24 x 16		23.50	15.50		970	6.7	
054862-028		24 x 18		23.50	17.50		1050	7.3	
054862-011		24 x 20		23.50	19.50		1165	8.0	
054862-005		24 x 24		23.50	23.50		1400	9.8	
054862-023		25 x 10		24.50	9.50		610	4.1	
054862-024		25 x 12		24.50	11.50		730	5.2	
054862-007		25 x 14		24.50	13.50		850	5.7	
054862-013		25 x 15		24.50	14.50		910	6.4	
054862-004		25 x 16		24.50	15.50		970	6.7	
054862-017		25 x 18		24.50	17.50		1100	7.6	
054862-003		25 x 20		24.50	19.50		1215	8.3	
054862-014		25 x 25		24.50	24.50		1520	10.5	



Farr 30/30®

High-Capacity MERV 8 Pleated Panel Filter

PERFORMANCE DATA (continued)

4" Deep Filter (actual filter depth 3.75")

Part Number	Nominal Depth (inches)	Nominal Size (inches)	Actual Size (Inches)			Initial Resistance (inches w.g.)	Airflow Capacity (cfm)	Total Media Area (sq. ft.)	Pleats per Linear Foot
			Depth	Height	Width				
059413-004	4	20 x 16	3.75	19.38	15.38	0.27	1100	15.7	11 pleats per linear foot
059413-003		20 x 20		19.38	19.38		1390	18.9	
059413-002		24 x 12		23.38	11.38		1000	13.9	
059413-009		24 x 18		23.38	17.38		1500	20.2	
059413-008		24 x 20		23.38	19.38		1670	22.7	
059413-001		24 x 24		23.38	23.38		2000	27.7	
059413-005		25 x 16		24.38	15.38		1390	19.7	
059413-006		25 x 20		24.38	19.38		1740	23.6	
059413-010		25 x 25		24.38	24.38		2170	30.0	
059413-007		25 x 29		24.38	28.38		2520	35.4	

Data Notes:

1.0" w.g. recommended final resistance for all depths. System design may dictate an alternative changeout point. Contact factory for guidance.

The 30/30 has been listed by Underwriters Laboratories as UL 900.

Maximum operating temperature 200° F (93° C).

2" and 4" deep filters rated at 250 feet per minute (fpm) medium and 500 fpm high. 1" deep filter's rated at 175 fpm medium and 350 fpm high.

For product specification in RTF format please go to www.camfil.com.



4" deep 30/30 is available with a header for side-access housing installation. Request Product Sheet 1003.

Specification

1.0 General

1.1 - Air filters shall be medium efficiency ASHRAE pleated panels consisting of cotton and synthetic media, welded wire media support grid, and beverage board enclosing frame.

1.2 - Sizes shall be noted on drawings or other supporting materials.

2.0 Construction

2.1 - Filter media shall be a cotton and synthetic blend, lofted to a uniform depth of 0.15", and formed into a uniform radial pleat.

2.2 - A welded wire grid, spot-welded on one-inch centers and treated for corrosion resistance shall be bonded to the downstream side of the media to maintain radial pleats and prevent media oscillation.

2.3 - An enclosing frame of no less than 28-point high wet-strength beverage board shall provide a rigid and durable enclosure. The frame shall be bonded to the media on all sides to prevent air bypass. Integral diagonal support members on the air entering and air exiting side shall be bonded to the apex of each pleat to maintain uniform pleat spacing in varying airflows.

3.0 Performance

3.1 - The filter shall have a Minimum Efficiency Reporting Value of MERV 8 when evaluated under the guidelines of ASHRAE Standard 52.2. It shall also have a MERV-A of 8 when tested per Appendix J of the same standard. The media shall maintain or increase in efficiency over the life of the filter.

3.2 - Initial resistance to airflow shall not exceed 0.23", 0.31" or 0.27" w.g. at an airflow of 350, 500 or 500 fpm on 1", 2" or 4" deep models respectively.

3.3 - The filter shall have an Energy Cost Index (ECI) value of five stars.

3.4 - Filter shall be listed UL 900 by Underwriters Laboratories.

3.5 - Manufacturer shall provide evidence of facility certification to ISO 9001:2008.

3.6 - Manufacturer shall guarantee the integrity of the filter pack to 2.0" w.g.

Supporting Data - Provide product test report including all details as prescribed in ASHRAE Standards 52.2, including Appendix J. Air filters shall be Camfil Farr 30/30 or equal.

© Copyright Camfil # 1002 - 0416



Camfil | 1 North Corporate Drive, Riverdale, NJ 07457 | Tel: (973) 616-7300

www.camfil.com

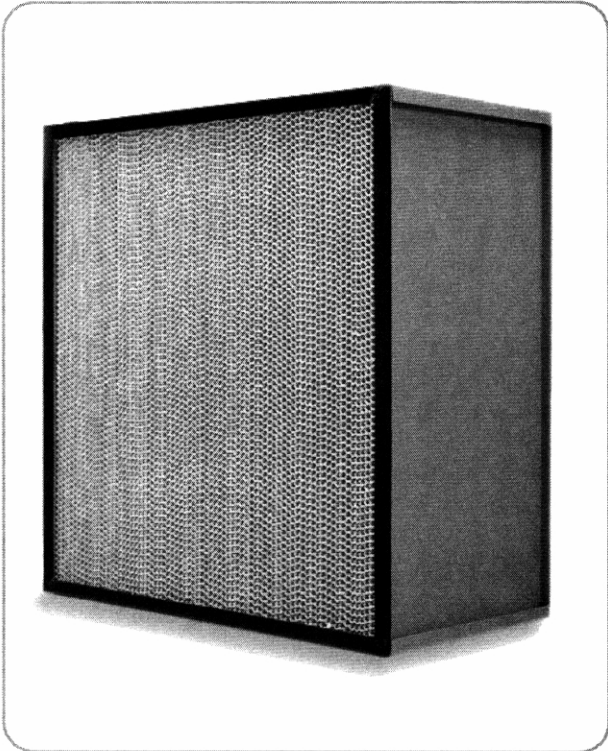

Camfil's high-capacity Absolute filters are manufactured from the highest quality components, under demanding quality control conditions, and are certified to ensure performance in the most critical of applications.

The XH is your choice for HEPA level air filtration in applications where ultra-clean air, increased airflow capacity and energy-savings are critical. Each XH Absolute includes:

- A galvanized 16-gauge steel frame to create a durable, dimensionally stable corrosion-resistant enclosure.
- X-Body frame that is assembled without the use of penetrating fasteners to ensure leak-free performance throughout the life of the filter.
- Our unique urethane potting process completely encapsulates the filter pack within the enclosing frame.
- Safe-edged tapered corrugated aluminum separators (allowing up to 88% more media area than standard HEPA filters) to ensure uniform airflow and stability throughout the pack. The edges of the separators are hemmed for added strength and to protect the media from damage during manufacture, shipping and installation.
- Micro glass fiber media to provide efficiencies from 99.97% @ 0.3 μ m to 99.999% @ 0.3 μ m. The media is highly resistant to moisture in high humidity environments.
- A one-piece seamless urethane gasket to ensure a leak-free filter to frame seal. A neoprene dove-tailed juncture gasket and a gel seal are also available.
- Every Camfil Absolute filter meets IEST-RP-CC001 performance levels.

Tapered separators allow increased media area for energy savings or more airflow in air-starved systems

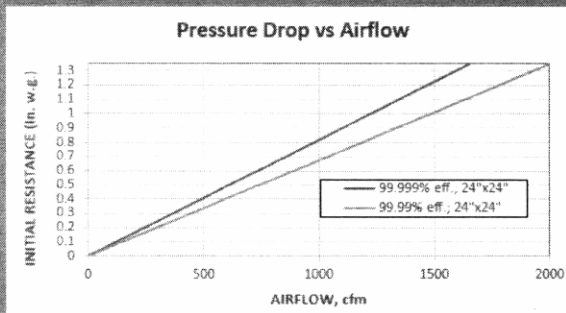

Gel Seal

Performance Data

Model	Efficiency	Nominal Size (inches)	Airflow @ 1.35" w.g.	Media Area (sq. ft.)	Shipping Weight (lbs)
01XH12Z12Z12- ** -3-CA00-0/00	99.97% @ 0.3µm EST Type A	12 x 12 x 11.50	430	67.5	23.6
01XH23F11F12- ** -3-CA00-0/00		23.38 x 11.38 x 11.50	850	134.6	30.8
01XH24Z12Z12- ** -3-CA00-0/00		24 x 12 x 11.50	930	145.5	32
01XH11F23F12- ** -3-CA00-0/00		11.38 x 23.38 x 11.5	850	134.6	34.7
01XH12Z24Z12- ** -3-CA00-0/00		12 x 24 x 11.50	930	145.5	35.6
01XH23F23F12- ** -3-CA00-0/00		23.38 x 23.38 x 11.50	1890	287.5	47.5
01XH24Z24Z12- ** -3-CA00-0/00		24 x 24 x 11.50	2000	301	48.5
12XH12Z12Z12- ** -3-CA00-0/00	99.99% @ 0.3µm EST Type C	12 x 12 x 11.50	430	67.5	23.6
12XH23F11F12- ** -3-CA00-0/00		23.38 x 11.38 x 11.50	850	134.6	30.8
12XH24Z12Z12- ** -3-CA00-0/00		24 x 12 x 11.50	930	145.5	32
12XH11F23F12- ** -3-CA00-0/00		11.38 x 23.38 x 11.5	850	134.6	34.7
12XH12Z24Z12- ** -3-CA00-0/00		12 x 24 x 11.50	930	145.5	35.6
12XH23F23F12- ** -3-CA00-0/00		23.38 x 23.38 x 11.50	1890	287.5	47.5
12XH24Z24Z12- ** -3-CA00-0/00		24 x 24 x 11.50	2000	301	48.5
13XH12Z12Z12- ** -3-CA00-0/00	99.999% @ 0.3µm IEST Type D	12 x 12 x 11.50	350	67.5	23.6
13XH23F11F12- ** -3-CA00-0/00		23.38 x 11.38 x 11.50	700	134.6	30.8
13XH24Z12Z12- ** -3-CA00-0/00		24 x 12 x 11.50	770	145.5	32
13XH11F23F12- ** -3-CA00-0/00		11.38 x 23.38 x 11.50	700	134.6	34.7
13XH12Z24Z12- ** -3-CA00-0/00		12 x 24 x 11.50	770	145.5	35.6
13XH23F23F12- ** -3-CA00-0/00		23.38 x 23.38 x 11.50	1550	287.5	47.5
13XH24Z24Z12- ** -3-CA00-0/00		24 x 24 x 11.50	1650	301	48.5

H →

DATA NOTES:
 Maximum operating temperature 175° F (80° C). If neoprene gasket is used temperature limitation is 200° F (93° C).
 The Camfil Absolute XH is listed by Underwriters Laboratories as UL 900 and UL 586. IEST=Institute of Environmental Sciences & Technology.
 Replace ** in model number with 00 for no gasket, 1D for one gasket downstream, 1U for one gasket upstream, or 1B for a gasket on both sides.
 Custom sizes available. Call customer service for gel gasket availability.

1.0 General

1.1 - Air filters shall be HEPA grade high-capacity air filters with waterproof micro glass fiber media, tapered corrugated aluminum separators, urethane sealant, 16-gauge steel enclosing frame, and (peel-and-stick neoprene sealing gasket, polyurethane seamless gasket, or gel seal)*.

1.2 - Sizes shall be as noted on drawings or other supporting materials.

2.0 Construction

2.1 - Filter media shall be one continuous pleating of micro-glass fiber media.

2.2 - Pleats shall be uniformly separated by tapered corrugated aluminum separators incorporating a hemmed edge to prevent damage to the media.

2.3 - The media pack shall be potted into the enclosing frame through the use of a urethane sealant.

2.4 - The enclosing frame of 16-gauge steel with a zinc aluminum alloy finish, shall be bonded to the media pack to form a rugged and durable enclosure. The filter shall be assembled without the use of fasteners to assure no frame penetrations. Overall dimensional tolerance shall be correct within -1/8", +0",

and square within 1/8".

2.5 - A (poured-in-place seamless polyurethane gasket, dovetail-cornered peel-and-stick neoprene gasket or gel seal) shall be included on the downstream side of the enclosing frame to form a positive seal upon installation.

3.0 Performance

3.1 - The filter shall have a tested efficiency of (99.97%, 99.99%, 99.999%)* as defined by IEST RP-CC001.

3.2 - Initial resistance to airflow shall not exceed 1.35" w.g. +/-10% at rated capacity.

3.3 - Filter shall be rated by Underwriters Laboratories as UL- 900 and UL-586.

3.4 - The filter shall be capable of withstanding 10" w.g. without failure of the media pack.

3.5 - Manufacturer shall provide evidence of facility certification to ISO 9001:2015.

Supporting Data - The filter shall be labeled as to tested efficiency, rated/tested airflow, pressure drop and shall be serialized for identification.

Filters shall be Camfil XH Series Absolute or equal.

* Items in parentheses () require selection.



For detailed specifications, please consult your local Camfil distributor, representative or XH Absolute. Camfil has a policy of uninterrupted research, development and product improvement. We reserve the right to change designs and specifications without notice.

Camfil | 1 North Corporate Drive, Riverdale, NJ 07457 | Tel: (973) 616-7300



CamContain™ Bags & Accessories

PVC Change-Out Bags & Accessories

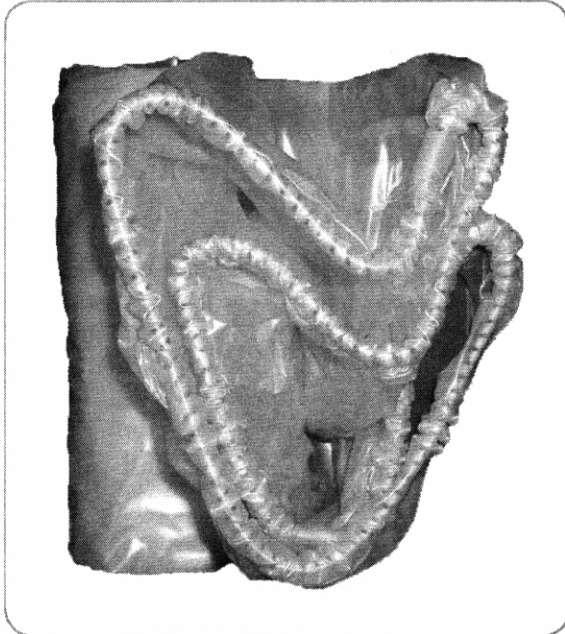

Camfil Bags

Available with various options, Camfil bags meet stringent industry requirements. Bags are constructed of a translucent 8-mil thick poly vinyl chloride that allows service personnel to view progress as filters are changed.

Each bag has an elastic shock cord hemmed into the mouth of the bag so the bag fits securely around housing opening. Every bag is identified on a label attached to the shock cord at the bag opening. Each bag also includes three glove openings. This additional opening facilitates easier handling of filtration during change and provides a convenient used bag removal receptacle.

Camfil can also supply custom-sized replacement bags for any brand of bag-in/bag-out housing. The only information required is the bagging ring circumference and the number of glove sleeves.

Banding Kit

A banding kit that includes a case/lap apron, a heavy duty tie-banding gun, PVC bag cutting shears, a 7" cinching hook-and-loop fastener security/safety strap and ten 100 pound tensile strength banding ties. The kit includes every item and tool needed to facilitate a filter change.

Security Straps

A nylon security strap helps to hold the bag over the bagging ring during the change out process. The security strap includes a reverse-ring and hook-and-loop strips to secure the ends.

Cinching Straps

A cinching strap prevents the bag from being drawn into the housing during operation. The strap is tied at a point near the lip of the door opening. Bag slack is then stored behind the housing door.

Banding Ties

Banding ties are used to isolate items of disposal from the newly installed bag section and filters. Camfil banding ties have a tensile strength of 100 pounds and are shipped in packages of ten.

**PVC bags, and accessories,
manufactured under the
same quality assurance
criteria as the housing.**



**Security
Strap**

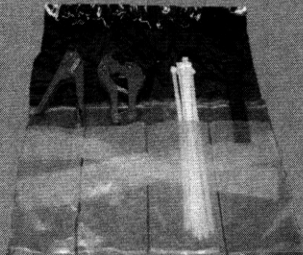

Banding Kit
Includes tie-banding gun, PVC
shears, banding ties and a security
strap in a convenient pouch/apron.



CamContain™ Bags & Accessories

PVC Change-Out Bags & Accessories

Performance Data

Gasket Seal Housings

HOUSING DESCRIPTION	PART #	BAG SIZE	
1/2 HIGH 012-1GB	M61000006	56C X 72/3G	
1/2 HIGH 212-1GB	M61000014	63C X 72/3G	
1/2 HIGH 212-3GB; 2 Bags	M61000002	42C X 72/3G	Prefilter Door
	M61000006	56C X 72/3G	HEPA Door
1 HIGH 012-1GB	M61000022	80C X 96/3G	
1 HIGH 212-1GB	M61000026	86C X 96/3G	
1 HIGH 212-3GB; 2 Bags	M61000018	64C X 72/3G	Prefilter Door
	M61000022	80C X 96/3G	HEPA Door
1 HIGH 016-1GB	M61000030	94C X 96/3G	
1 HIGH 216-1GB	M61000103	96C X 96/3G	
1 HIGH 216-3GB; 2 Bags	M61000018	64C X 72/3G	Prefilter Door
	M61000030	94C X 96/3G	Carbon Door
1 HIGH 018-1GB	M61000030	94C X 96/3G	
1 HIGH 218-1GB	M61000046	102C X 96/3G	
1 HIGH 218-3GB; 2 Bags	M61000018	64C X 72/3G	Prefilter Door
	M61000030	94C X 96/3G	Carbon Door

Custom bags available for all housings; the only information required is the bagging ring circumference and the number of glove sleeves, contact factory for pricing and manufacturing lead time.

Gel Seal Housings

HOUSING DESCRIPTION	PART #	BAG SIZE	
1/2 HIGH 012-1FB	M61000014	63C X 72/3G	
1/2 HIGH 212-3FB; 2 BAGS	M61000002	42C X 72/3G	PREFILTER DOOR
	M61000014	63C X 72/3G	HEPA DOOR
1 HIGH 012-1FB	M61000026	86C X 96/3G	
1 HIGH 212-3FB; 2 BAGS	M61000018	64C X 72/3G	PREFILTER DOOR
	M61000026	86C X 96/3G	HEPA DOOR
1 HIGH 016-1FB	M61000183	96C X 96/3G	
1 HIGH 216-3FB; 2 BAGS	M61000018	64C X 72/3G	PREFILTER DOOR
	M61000183	96C X 96/3G	CARBON DOOR
1 HIGH 018-1FB	M61000046	102C X 96/3G	
1 HIGH 218-3FB; 2 BAGS	M61000018	64C X 72/3G	PREFILTER DOOR
	M61000046	102C X 96/3G	CARBON DOOR

Accessory	Part Number
Banding Kit	M34001023
Security/Safety Strap - 80"	M34001035
Security/Safety Strap - 100"	M34001036
Security/Safety Strap - 112"	M34001037
Security/Safety Strap - 120"	M34001038
Cinching Strap	M34001044
Banding Ties (10-Pack)	M34001021
Aluminum Star Knob	M36001000
Filter Change Manual/CD	M34001041

2
2

Replacement Bags

Replacement bags shall be non-sticking and constructed of 8-mil thick poly vinyl chloride with a yellow translucent, matte finish. A 1/4-inch diameter elastic shock cord shall be hemmed into the opening of the bag so that when stretched around the bagging flange, the bag fits securely. The bag shall include three glove ports as an integral component to assist in the filter change-out. Containment bags shall be suitable for continuous operating temperatures to 150° F (66° C).

Banding Kit

Manufacturer shall supply a banding kit that includes a case/lap apron, a heavy duty tie-banding gun, PVC bag cutting shears, a 7" cinching hook-and-loop security/safety strap and ten 100 pound tensile strength banding ties.

Security/Safety Strap

(#) security/safety strap(s) of nylon construction shall be included. The strap(s) shall include a reverse-ring and hook-and-loop fasteners on the end to secure strap during change.

Cinching Strap

(#) 7-inch cinching strap(s) of nylon construction shall be included.

Banding Ties

(#, multiples of 10) banding ties with a tensile strength of 100 pounds shall be included.

Items in parentheses () denote optional selections.
Replace with required quantity.

For detailed specifications please consult your local Camfil Distributor or Representative or www.camfil.com.
Camfil has a policy of uninterrupted research, development and product improvement. We reserve the right to change designs and specifications without notice.



Direct factory assistance:
Telephone: (252) 975-1141
Fax: (252) 948-3636



Camfil USA | 1 North Corporate Drive, Riverdale, NJ 07457 | Tel: (973) 616-7300