

Quality People. Building Solutions.

Comfort Systems USA (Arkansas), Inc.
P.O. Box 16620
Little Rock, AR 72231
Phone 501-834-3320
Fax 501-834-5416

Date: 11/20/2024

Return Request: 11/30/2024

Project: UAMS (CAMID)

Supplier: Harrison Energy

Manufacturer: Daikin

Submittal: Mini Splits

Submittal Number: 23 00 00-03

Drawing # and Installation: Mechanical Drawings

ARCHITECT

Clark Kenersen
2020 Baltimore Avenue, Suite 300
Kansas City, MO 64108
816-474-8237

ENGINEER

Clark Kenersen
2020 Baltimore Avenue, Suite 300
Kansas City, MO 64108
816-474-8237

GENERAL CONTRACTOR

CDI Contractirs
3000 Cantrell Rd.
Little Rock, AR 72202
501-666-4300

MECHANICAL SUBCONTRACTOR

Comfort Systems USA (Arkansas), Inc.
9924 Landers Rd.
N. Little Rock, AR 72117
501-834-3320

Notes:

CSUSA PROJECT NO.

22-6069

sean@comfortar.com

9924 Landers Rd.
No. Little Rock, AR 72117



Submittal

Prepared For:
Clark & Enerson

Date:
November 1, 2024

Sold To:
Comfort Systems USA

Job Name:
UAMS CAMID

Harrison Energy Partners is pleased to provide the enclosed submittal for your review and approval.

Qty.	Product Summary
2	Daikin Mini Splits

Josh Robinson | Sales Engineer
Harrison Energy Partners
1501 Westpark Drive, Suite 9
Little Rock, AR 72204-2457
Ph. 501-539-0633

The attached information describes the equipment we propose to furnish for this project, and is submitted for your approval.

Ductless Mini Splits

Tag	Qty.	Description	Model Number
DSS-109 and 152	2	Mini Splits	Daikin FTKF24/RKF24

- Cooling only mini split
- 2 ton
- Wall mounted indoor unit
- Wind baffle for low ambient operation
- Condensate pump



Submittal Data Sheet

R-32 --- 2-Ton Wall Mounted Daikin OTERRA Cooling Only System - FTKF24AXVJU-RKF24AXVJU

Project: UAMS CAMID

Submitted by: Josh Robinson of HARRISON ENERGY PARTNERS on 11/1/2024

Submitted to: None

FEATURES

- Daikin Swing Compressor
- Indoor Quiet Operation
- Included Handheld Remote
- Titanium Apatite Air-Purifying Filter
- Anti-corrosion Treatment of Outdoor Heat Exchanger

BENEFITS

- R-32 Easy, Proven, Efficient, Available
- Precharged for up to 33 ft
- Cooling Operation Range - 50-118F for 9K/12K 50-122F for 18/24K
- 12 Year Parts and Compressor Registered Residential Warranty
- 5 year Parts and Compressor Commercial Warranty
- Cooling down to -4F for Facilities

INDOOR UNIT



OUTDOOR UNIT





Submittal Data Sheet

R-32 --- 2-Ton Wall Mounted Daikin OTERRA Cooling Only System - FTKF24AXVJU-RKF24AXVJU

Project: UAMS CAMID

Submitted by: Josh Robinson of HARRISON ENERGY PARTNERS on 11/1/2024

Submitted to: None

SYSTEM PERFORMANCE

Indoor Unit Model No.	FTKF24AXVJU	Indoor Unit Name:	R-32 Daikin OTERRA 2 Ton AC only mini split indoor unit
Outdoor Unit Model No.	RKF24AXVJU	Outdoor Unit Name:	R-32 2 Ton, Cooling only, Ductless ODU Daikin OTERRA
Rated Cooling Capacity (Btu/hr):	22,400	Rated Cooling Conditions:	Indoor (°F DB/WB): 80 / 67 Ambient (°F DB/WB): 95 / 75
Sensible Capacity (Btu/hr):	16,360	Rated Piping Length(ft):	25
Max/Min Cooling Capacity (Btu/hr):	26,400 / 7,000	Rated Height Difference (ft):	0.00
Cooling Input Power (kW):	6.570		
SEER2 (Non-Ducted/Ducted):	21.00 /		
EER2 (Non-Ducted/Ducted):	12.00 /		

SYSTEM DETAILS

Refrigerant Type:	R-32	Cooling Operation Range (°F DB):	50 - 122
Holding Refrigerant Charge (lbs):	3.31		
Additional Charge (oz/ft):	0.18	Max. Pipe Length (Vertical) (ft):	66
Pre-charge Piping (Length) (ft):	33	Cooling Range w/Baffle (°F DB):	-4 - -4
Max. Pipe Length (Total) (ft):	99		
Max Height Separation (Ind to Ind ft):	0		



Submittal Data Sheet

R-32 --- 2-Ton Wall Mounted Daikin OTERRA Cooling Only System - FTKF24AXVJU-RKF24AXVJU

Project: UAMS CAMID

Submitted by: Josh Robinson of HARRISON ENERGY PARTNERS on 11/1/2024

Submitted to: None

INDOOR UNIT DETAILS

Power Supply (V/Hz/Ph):	208-230 / 60 / 1	Airflow Rate (HH/H/M/L/SL) (CFM):	754/716/605/467/395
Power Supply Connections:	L1, L2, L3, Ground	Moisture Removal (Gal/hr):	0.9
Min. Circuit Amps MCA (A):		Gas Pipe Connection (inch):	5/8
Max Overcurrent Protection (MOP) (A):		Liquid Pipe Connection (inch):	1/4
Dimensions (HxWxD) (in):	11-11/16 x 39-9/16 x 10-3/4	Condensate Connection (inch):	5/8
Net Weight (lb):	30.5	Sound Pressure (H/M/L/SL) (dBA):	53/45/39/34
Ext. Static Pressure (Rated/Max) (inWg):	/	Sound Power Level (dBA):	

DIMENSIONAL DRAWING - INDOOR UNIT

Model : FTKF18/24A, FTXF18/24A

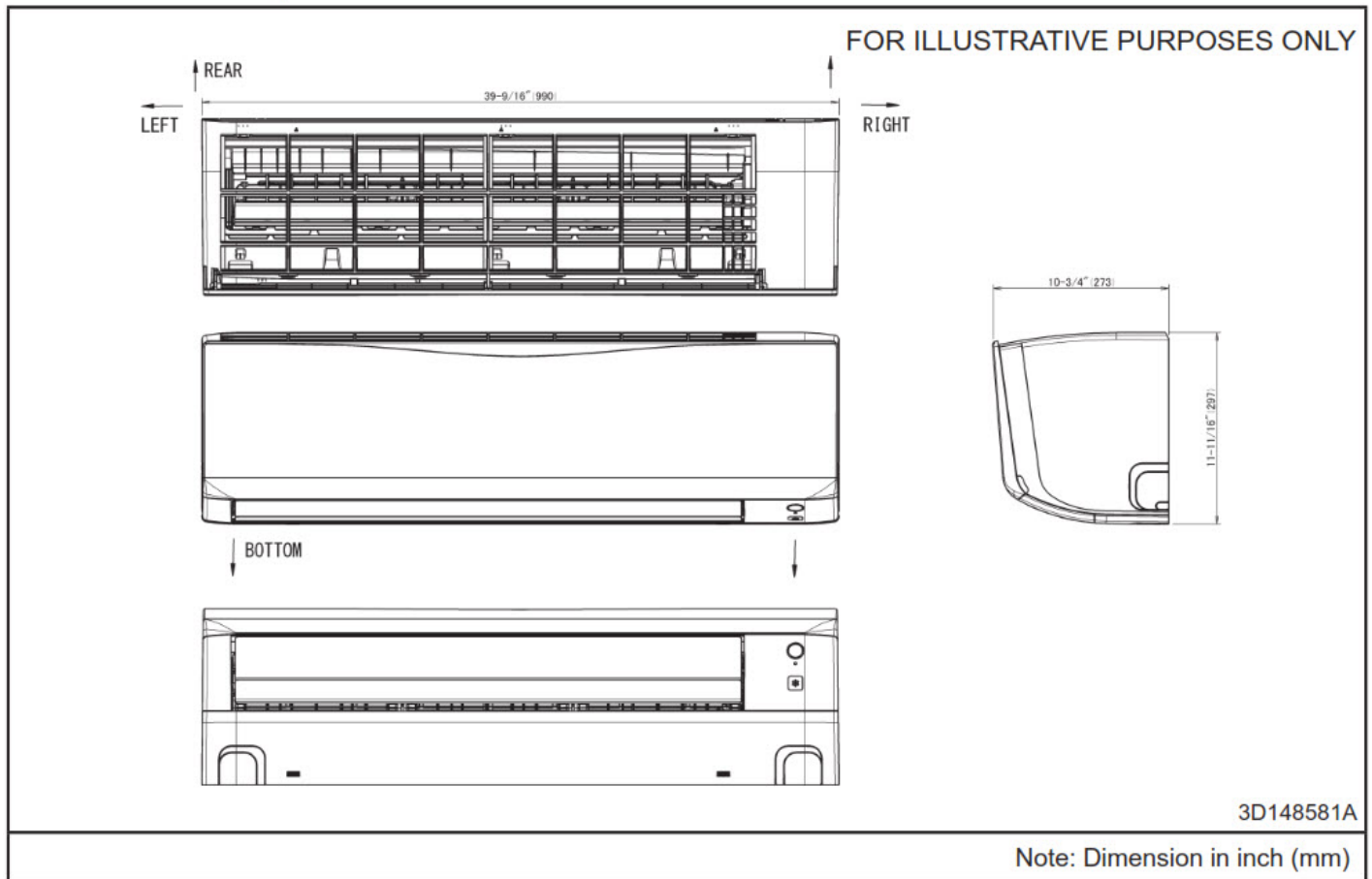

Submittal Data Sheet

R-32 --- 2-Ton Wall Mounted Daikin OTERRA Cooling Only System - FTKF24AXVJU-RKF24AXVJU

Project: UAMS CAMID

Submitted by: Josh Robinson of HARRISON ENERGY PARTNERS on 11/1/2024

Submitted to: None

OUTDOOR UNIT DETAILS

Power Supply (V/Hz/Ph):	208-230 / 60 / 1	Compressor Stage:	Inverter
Power Supply Connections:	L1, L2, L3, Ground	Capacity Control Range (%):	-
Min. Circuit Amps MCA (A):	14.23	Airflow Rate (H) (CFM):	1879
Max Overcurrent Protection (MOP) (A):	20	Gas Pipe Connection (inch):	5/8
Max Starting Current MSC(A):		Liquid Pipe Connection (inch):	1/4
Rated Load Amps RLA(A):		Sound Pressure (H) (dBA):	55
Dimensions (HxWxD) (in):	27-13/32 x 36-5/8 x 13-13/16	Sound Power Level (dBA):	
Net Weight (lb):	101		

DIMENSIONAL DRAWING - OUTDOOR UNIT

Model : RKF18/24A, RXF18/24A

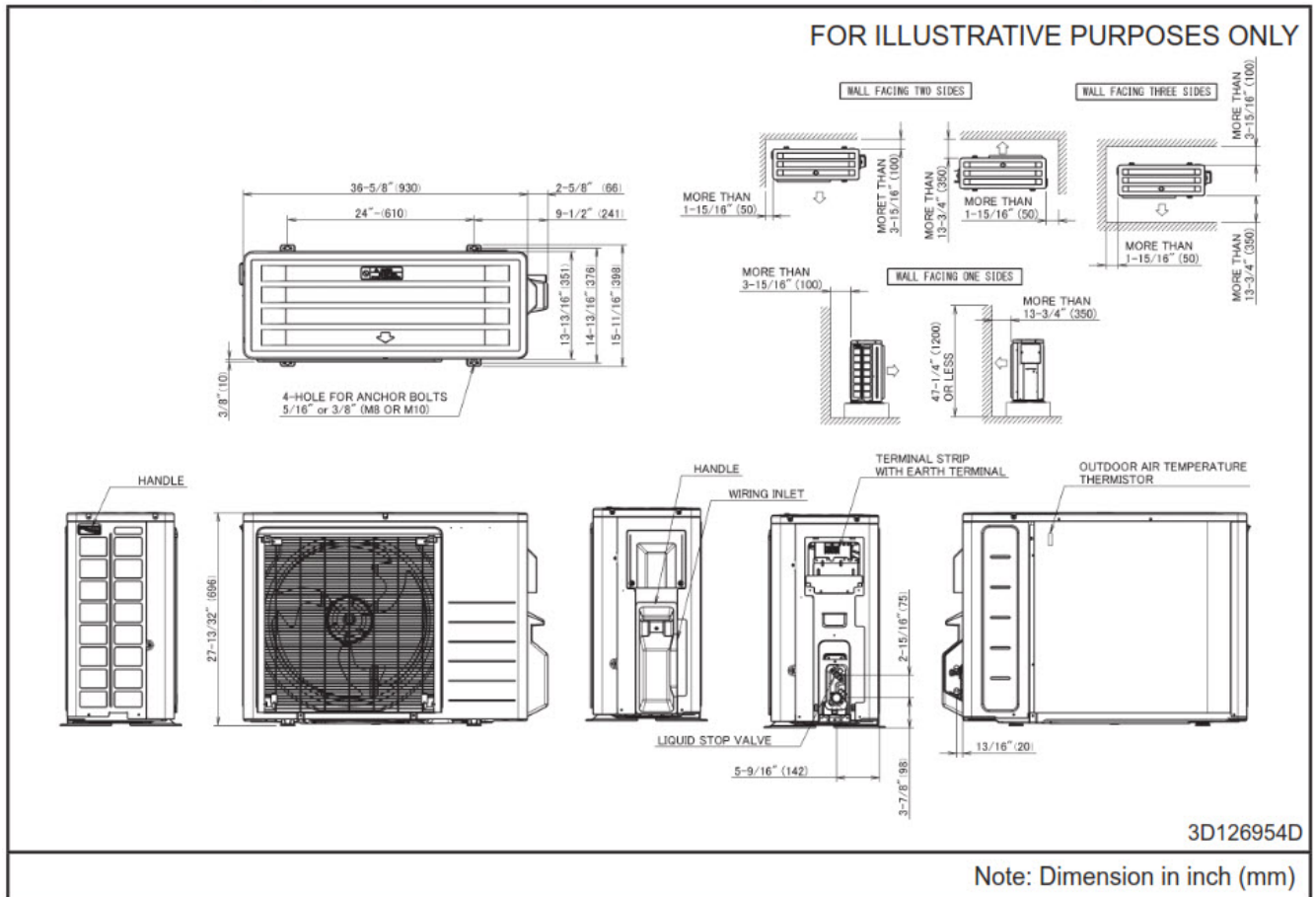



Submittal Data Sheet

R-32 --- 2-Ton Wall Mounted Daikin OTERRA Cooling Only System - FTKF24AXVJU-RKF24AXVJU

Project: UAMS CAMID

Submitted by: Josh Robinson of HARRISON ENERGY PARTNERS on 11/1/2024

Submitted to: None

INDOOR ACCESSORIES

PART NUMBER	DESCRIPTION	INCLUDED
-------------	-------------	----------

AZAI6WSCDKB	DKN Residential Cloud Wi-Fi Adaptor for Single- and Multi-Zone System (S21)	No
AZAI6WSPDKC	DKN Plus Interface	No
BRC51D61	Wired Remote Controller Kit	No
DACA-CP1-1	Mini Aqua Condensate Pump	No
DACA-CP4-1	MINI WHITE PUMP KIT 100-250V	No
DTST-LTE-LA-A	Daikin One Lite (with Translation Adaptor for S21 only)	No
DTST-ONE-ADA-A	Daikin One+ Smart Thermostat for VRV, SkyAir, Single- and Multi-Zone System	No
DTST-TOU-ADA-A	Daikin One Touch Smart Thermostat (with Translation Adaptor for S21 and P1P2)	No
KRP928BB2S	RA Interface Adaptor for DIII-Net -	No

OUTDOOR ACCESSORIES

PART NUMBER	DESCRIPTION	INCLUDED
-------------	-------------	----------

DACA-WB-3	Powder-Coated Wall-Mounted Bracket	No
KEH063A4EA	Bml LRg Drain Pan Heater Rev A	No
KPW063B4E	Air Adjustment Grille	No

Submittal Data Sheet

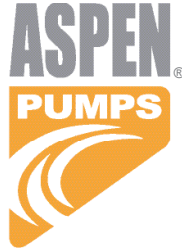

DACA-CP1-1

Mini Univolt 100-250 Pump Kit DACA-CP1-1

Project Information:

Job Name:

Location:

Engineer:

Submitted to:

For: Reference Approval Construction

Submitted by:

Reference:

Submittal Information:

Approval:

Date:

Construction:

Unit #:

Drawing #:

(Sec. I) Product Specifications:

Pump Length - 6.5"
 Pump Width - 1.125"
 Pump Height - 1.125"
 Capacity - 3.2 GPH @ 0' Head
 Max BTUs - 30000
 Max Head in Feet - 33
 Max Temperature - 104F
 Max Suction Lift - 3'3"
 Sound Level - 25dB(A)
 Dry Contact Rating - 3A NC
 Voltage - 100-250
 Amperes - .15 MAX
 Watts - 16
 Remote Reservoir - Y
 Plenum Rated - N
 Cable Length - 6'

Pump Selector & Wiring Diagrams Available at
<http://www.rectorseal.com/index.php/daikin/>

(Sec. II) Ordering Information:

Product Code - DACA-CP1-1
 Model - DACA-CP1-1
 Carton Qty - 1
 Carton Weight - 1.5

(Sec. III) Carton Contents:

Pump Assembly	Drain Hose Adaptor
Inline Reservoir	Inline Fuse
8"x5/8" i.d. Inlet Tube	Cable Ties (6)
5'x1/4" i.d. Vinyl Discharge Tube	Self Adhesive Velcro Strips (2)
Installation Manual	Anti-siphon (1)
6"x1/4" i.d. Vinyl Breather Tube	

(Fig. I) Product Image:



(Fig. II) Typical Pump Locations:

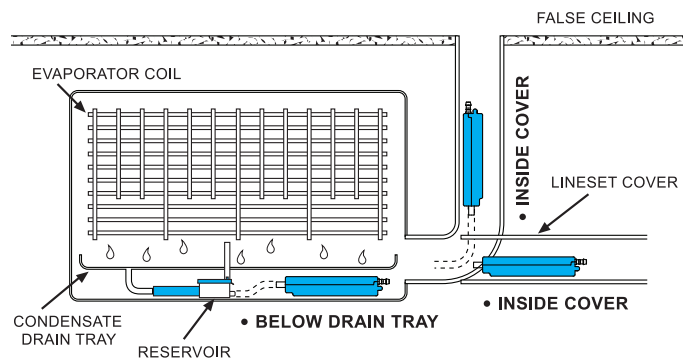

(RectorSeal's products are subject to continuous improvements; RectorSeal reserves the right to modify product design, specifications & information in this data sheet without notice and without incurring any obligations)
 ASPEN® is a registered trademark of Aspen Oldco Limited Company UK

Project Name:	Approval:
Location:	Date:
Engineer:	Construction:
Submitted to:	Unit #:
Submitted by:	Drawing #:
Reference:	

MODEL COMPATIBILITY:

Compatible with Single-Zone system indoor unit models:

Indoor Unit Models	Interface Adaptor
FTKB09AXVJU, FTKB12AXVJU, FTKB18AXVJU, FTKB24AXVJU, FTXB09AXVJU, FTXB12AXVJU, FTXB18AXVJU, FTXB24AXVJU, FTXB09BXVJU, FTXB12BXVJU, FTXB18BXVJU, FTXB24BXVJU	Not needed
CTX07AXVJU, CTX09AXVJU, CTX12AXVJU, FTK09AXVJU, FTK12AXVJU, FTK18AXVJU, FTK24AXVJU, FTX09AXVJU, FTX12AXVJU, FTX18AXVJU, FTX24AXVJU, FTK09BXVJU, FTK12BXVJU, FTK18BXVJU, FTK24BXVJU, FTX09BXVJU, FTX12BXVJU, FTX18BXVJU, FTX24BXVJU	Not needed

SPECIFICATIONS:

Model	BRC51D61
Description	Wired Remote Controller Kit
Maximum Indoor Units	1
Total Wiring Length	32.8ft (10m)
Dimensions	4.72 in x 4.72 in x 0.78 in (120mm x 120mm x 19.5 mm)
Connection Point	CN_WIRED (FTK/XB_AXVJU) CN_NS (FTK/X_AXVJU, FTK/X_BXVJU, FTXB_BXVJU)
Comfort Setpoint Range	60°F – 86°F
Operation	Start / Stop
	Mode (Auto/Heat/Cool/Dry/Fan)
	Set Temperature Setpoint
	Fan Speed
	Airflow Direction
	Feature Selection (SLEEP, ECO+, POWERFUL, QUIET)
	Turn ON/OFF indoor unit LED display
Scheduling	Weekly ON/OFF Timer

PRODUCT IMAGE:





Submittal Data Sheet

BRC51D61 – Wired Remote Controller Kit

Project Name: _____

Location: _____

Engineer: _____

Submitted to: _____

Submitted by: _____

Reference: _____

Approval: _____

Date: _____

Construction: _____

Unit #: _____

Drawing #: _____

FEATURES:

- The Wired Remote Controller Kit includes a wired remote controller, a 32 ft. connecting cable and mounting screws.
- Selectable auto / cool / heat / dry / fan operation modes with adjustable setpoint and fan speed
- Set temperature setpoint in °F or °C units with 1 degree increments
- Temperature is controlled through indoor unit temperature sensor
- Built in weekly ON/OFF timer functionality with up to 2 ON/OFF cycles per day
- Can be used together with the factory supplied standard wireless remote controller – the system will follow the last command provided by either the handheld remote or BRC51D61.
- Room temperature display available via jumper – readout is return air temp at the indoor unit.
- System maintains a 3° to 5°F temperature correction of the set point, depending on the mode of operation.
- The unit runs based on a 1°C temperature control. The setpoint command will be rounded to °C and sent to the indoor unit. For some setpoints, the indoor unit temperature command may not change as shown in the table below.

User Setpoint on Controller (°F)	Actual Indoor Unit Setpoint (°F)
68	68
69	68
70	70
71	70
72	72
73	73
74	73
75	75
76	75
77	77
78	77
79	79
80	79
81	81
82	82

DAIKIN COMFORT TECHNOLOGIES NORTH AMERICA, INC.

19001 Kermier Road, Waller, TX, 77484

www.daikinac.com www.daikincity.com

Rev.0923

(Daikin's products are subject to continuous improvements. Daikin reserves the right to modify product design, specifications, and information in this data sheet without notice and without incurring any obligations)

Project Name: _____

Location: _____

Engineer: _____

Submitted to: _____

Submitted by: _____

Reference: _____

Approval: _____

Date: _____

Construction: _____

Unit #: _____

Drawing #: _____

DIMENSIONS:

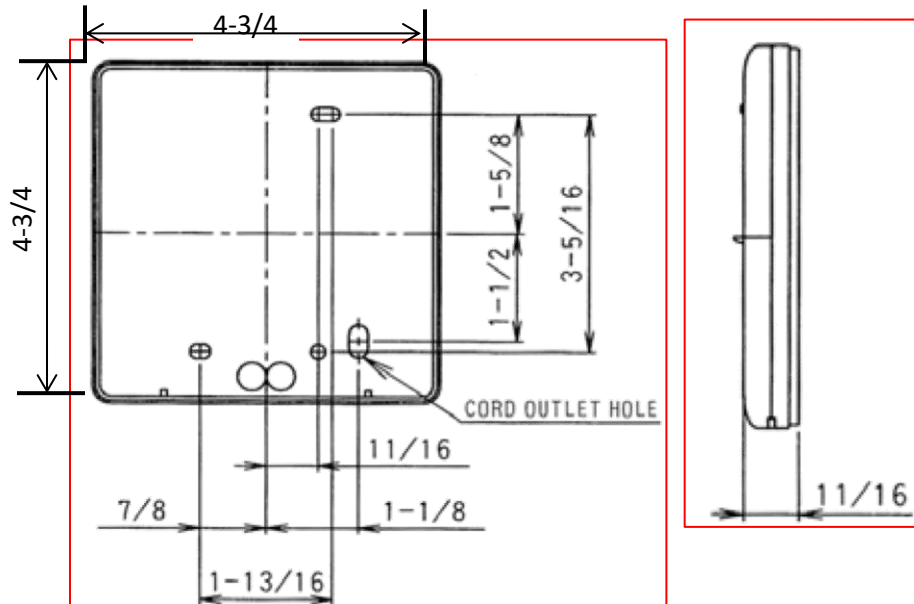

DOCUMENTATION:

Documentation available on www.daikincity.com and/or www.daikinac.com:

- Submittal
- Operation Manual (including installation instructions)



Submittal Data Sheet

Air Adjustment Grille (Wind Baffle)
KPW063B4E

DESCRIPTION

Air Adjustment Grille (Wind Baffle) mounts over the standard air grille and allows adjustment in air blow-off direction.

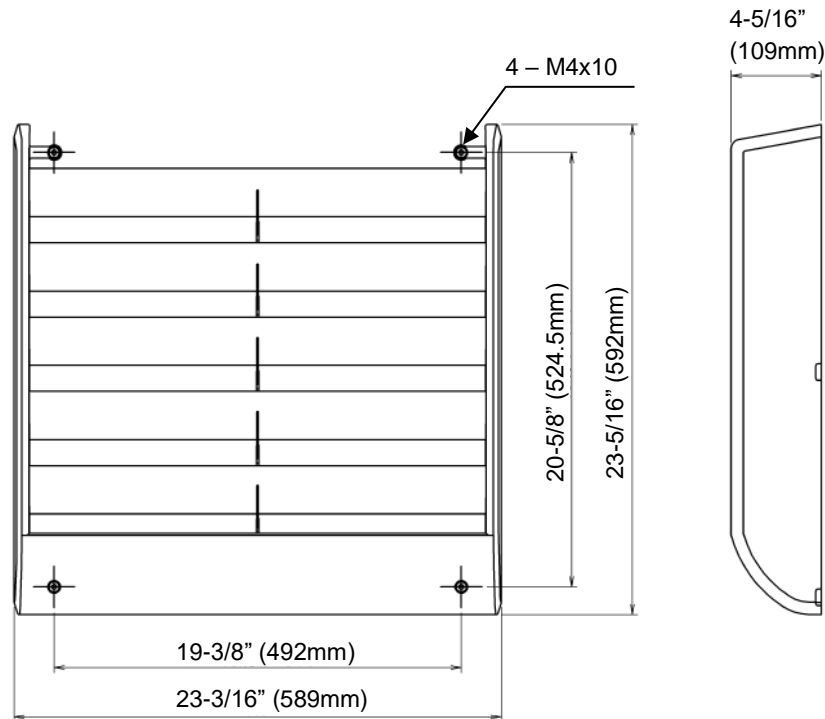

Image for REFERENCE ONLY

SPECIFICATIONS

Model No:	KPW063B4E	
Unit Compatibility:	RK18AXVJU, RK24AXVJU, RX18AXVJU, RX24AXVJU	Qty (1)
Unit Names:	Air Adjustment Grille (Wind Baffle)	
Dimensions (WxHxD):	23-3/16" x 23-5/16" x 4-5/16" (589mm x 592mm x 109mm)	
Shipping Unit Weight:	6 lb. (2.7 kg)	
Material:	Flame Retardant Grade UL94V-HB	

DIMENSIONAL DRAWING



Daikin North America LLC, 5151 San Felipe, Suite 500, Houston TX, 77056
www.daikinac.com www.daikincomfort.com

(Daikin's products are subject to continuous improvements. Daikin reserves the right to modify product design, specifications and information in this data sheet without notice and without incurring any obligations).