

Quality People. Building Solutions.

Comfort Systems USA (Arkansas), Inc.
P.O. Box 16620
Little Rock, AR 72231
Phone 501-834-3320
Fax 501-834-5416

Date: 1/25/2024

Return Request: 2/5/2024

Project: East End HVAC Replacement

Supplier: Dollar Sheetmetal

Manufacturer: Various

Submittal: Metal Ductwork

Submittal Number: 23 00 00-02

Drawing # and Installation: Mechanical Drawings

ARCHITECT

Lewis Architects Engineers
11225 Huron Lane, Suite 104
Little Rock, AR 72211
501-223-9302

ENGINEER

Lewis Architects Engineers
11225 Huron Lane, Suite 104
Little Rock, AR 72211
501-223-9302

GENERAL CONTRACTOR

Comfort Systems USA (Arkansas), Inc.
9924 Landers Rd.
N. Little Rock, AR 72117
501-834-3320

MECHANICAL SUBCONTRACTOR

Comfort Systems USA (Arkansas), Inc.
9924 Landers Rd.
N. Little Rock, AR 72117
501-834-3320

Notes:

CSUSA PROJECT NO.

24-2021

chowell@comfortar.com

9924 Landers Rd.
No. Little Rock, AR 72117

SUBMITTAL

Product: Ductwork (G-90)

Manufacturer: Dollar Sheet Metal, Inc.

Job Name: East End Elementary School

Location: Little Rock, AR

Date: January 24, 2024

HVAC DUCT CONSTRUCTION STANDARDS

METAL AND FLEXIBLE



ANSI/SMACNA 006-2006

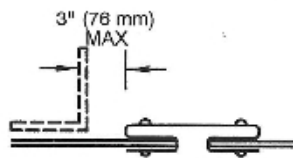


**SHEET METAL AND AIR CONDITIONING CONTRACTORS'
NATIONAL ASSOCIATION, INC.**
www.smacna.org

2 in. wg Static Pos. or Neg.	No Reinforcement Required	Reinforcement Code for Duct Gage Number							
		Reinforcement Spacing Options ↓							
		10 ft	8 ft	6 ft	5 ft	4 ft	3 ft	2½ ft	2 ft
①	②	③	④	⑤	⑥	⑦	⑧	⑨	⑩
10 in. and under	26 ga.	Not Required							
11 – 12 in.	26 ga.								
13 – 14 in.	24 ga.		B-26	B-26	B-26	B-26	B-26	B-26	B-26
15 – 16 in.	24 ga.		C-26	C-26	C-26	C-26	C-26	B-26	B-26
17 – 18 in.	22 ga.		C-26	C-26	C-26	C-26	C-26	C-26	B-26
19 – 20 in.	20 ga.	C-22	C-24	C-26	C-26	C-26	C-26	C-26	C-26
21 – 22 in.	18 ga.	D-22	D-24	D-26	D-26	C-26	C-26	C-26	C-26
23 – 24 in.	18 ga.	E-22	E-24	D-26	D-26	D-26	C-26	C-26	C-26
25 – 26 in.	18 ga.	E-22	E-22	E-24	D-26	D-26	C-26	C-26	C-26
27 – 28 in.	18 ga.	F-20	E-20	E-22	E-24	D-26	D-26	C-26	C-26
29 – 30 in.	18 ga.	F-20	F-20	E-22	E-24	E-26	D-26	D-26	C-26
31 – 36 in.	16 ga.	G-18	G-20	F-22	F-24	E-24	E-26	D-26	D-26
37 – 42 in.		H-16	H-18	G-20	G-22	F-24	E-24	E-26	E-26
43 – 48 in.			I-18	H-20	H-22	G-22	F-24	F-24	E-24
49 – 54 in.			I-16G	I-18G	H-20G	H-20G	G-24	F-24	F-24
55 – 60 in.				I-18G	I-20G	H-20G	G-22	G-24	F-24
61 – 72 in.		Not Designed		J-16H	J-18H	I-20G	H-22G	H-22G	H-24
73 – 84 in.					J-16H	I-20G	I-20G	I-22G	I-22G
85 – 96 in.						J-18H	I-18H	I-20H	I-22H
97 – 108 in.						K-16I	K-18H	J-18H	I-18H
109 – 120 in.							K-16I	K-18I	J-18I

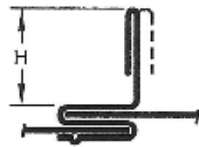
Table 2-3 Rectangular Duct Reinforcement



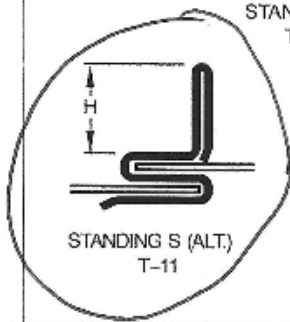


T-8 DOUBLE "S" SLIP
(T-8a REINFORCED)

- 24 ga for 30 inch width or less
- 22 ga over 30 inch width
- Fasten to each section of the duct within 2 in. from corners and at 6 in. maximum intervals
- 5/8 in. minimum tabs to close corners



STANDING S
T-10

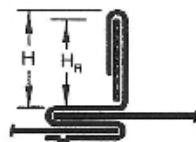


STANDING S (ALT.)
T-11



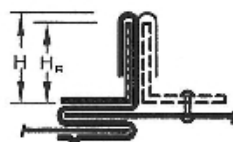
STANDING S (ALT.)
T-12

- When using S on all four sides, fasten slip to duct within 2 in. of the corner and at 12 in. maximum intervals
- Any length at 2 in. wg
- 36 in. maximum length at 3 in. wg
- 30 in. maximum length at 4 in. wg ←
- Not allowed above 4 in. wg



STANDING S
(BAR REINFORCED)
T-13

- Fasten as per Joint T-10
- Standing portion as per T-10 or T-11 to hold Flat Bar
- Fasten bar stock to the connector within 2 in. of the corner and at 12 in. maximum intervals
- Any length at 2 in. wg
- 36 in. maximum length at 3 in. wg
- 30 in. maximum length at 4 in. wg
- Not allowed above 4 in. wg

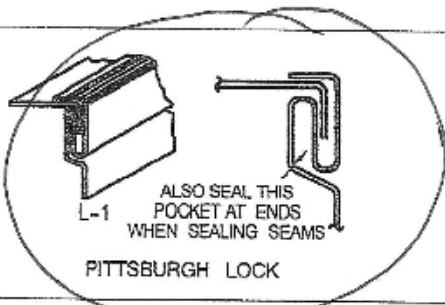


STANDING S
(ANGLE REINFORCED)
T-14

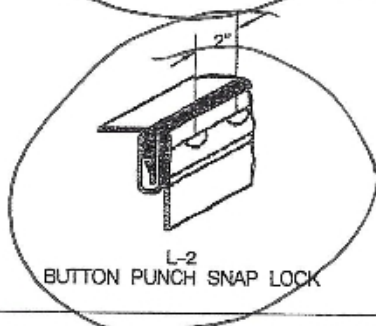
- Fasten as per Joint T-10
- Fasten angle to the connector or duct wall within 2 in. of the corner and at 12 in. maximum intervals
- Any length at 2 in. wg
- 36 in. maximum length at 3 in. wg
- 30 in. maximum length at 4 in. wg
- Not allowed above 4 in. wg

FIGURE 2-1 RECTANGULAR DUCT/TRANSVERSE JOINTS (CONTINUED)





- Pocket depth from ¼ in. to ⅝ in.
- Use on straight duct and fittings
- To ± 10 in. wg



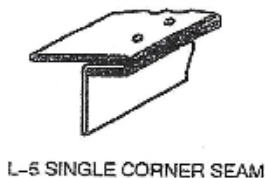
- ⅝ in. pocket depth for 20, 22, and 24 ga
- ½ in. pocket depth for 24 and 26 ga
- To ± 4 in. wg
- Screws must be added at the ends of all duct of 4 in. wg and at the ends of 3 in. wg when the duct is over 48 in. width



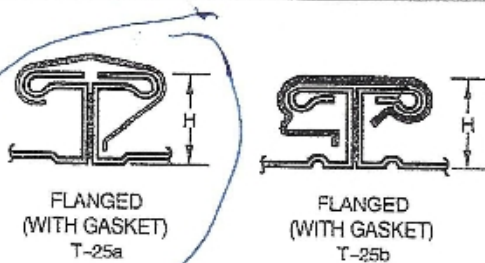
- To ± 10 in. wg



- To ± 10 in. wg
- 1 in. seam up to duct width of 42 in.
- 1 ½ in. seam for larger ducts
- May be used on duct interiors
- Fasten at 2 in. maximum from ends and at 8 in. maximum intervals



- To ± 10 in. wg
- Fasten as per L-4



- Assemble per Figure 2-17
- Ratings may be adjusted with EI-rated bar stock or members from Tables 2-29 and 2-30
- Supplemental members may be attached to the duct wall on both sides of the joint
- Single members may be used if they are fastened through both mating flanges
- Gasket to be located to form an effective seal

FIGURE 2-2 RECTANGULAR DUCT/LONGITUDINAL SEAMS

Reinf. Class	T-2 Standing Drive Slip		T-10 Standing S		T-11 Standing S		T-12 Standing S		T-14 Standing S		
	El*	H x T	WT	H x T	WT	H x T	WT	H x T	WT	H x T + HR	
			LF		LF		LF		LF		LF
A	0.43	Use B		Use B		1/2 x 26 ga	0.5	Use B		Use D	
B	1.0	1 1/8 x 26 ga	0.4	1 x 26 ga	0.6	1/2 x 22 ga 1 x 26 ga	0.6	1 x 26 ga	0.7	Use D	
C	1.9	1 1/8 x 22 ga	0.6	1 x 22 ga	0.8	1 x 22 ga	0.8	1 x 24 ga	0.8	Use D	
D	2.7	1 1/8 x 18 ga	0.8	1 1/8 x 20 ga 1 x 22 ga (+)	0.9	1 x 20 ga 1 x 22 ga (+)	0.9	1 1/2 x 22 ga	1.0	1 5/8 x 24 ga 1 1/2 x 1/8 Bar	1.4
E	6.5	NOT GIVEN		1 1/8 x 18 ga	1.0	1 x 18 ga (+)	1.0	1 x 18 ga 1 1/2 x 20 ga	1.2	Use F	
F	12.8			Use G		NOT GIVEN		Use G		1 5/8 x 22 ga 1 1/2 x 1/8 Bar	1.5
G	15.8			1 5/8 x 18 ga	1.3			1 1/2 x 18 ga	1.3	1 5/8 x 20 ga 1 1/2 x 1/8 Bar	1.7
H	26.4			1 5/8 x 18 ga 1 1/2 x 1/8 Bar	2.0						
I	69			2 1/8 x 20 ga 2 x 2 x 1/8 Angle	2.9						
J	80			2 1/8 x 20 ga 2 x 2 x 3/16 Angle	3.7						
K	103			NOT GIVEN							
L	207										

Table 2-31 Transverse Joint Reinforcement

See Section 2.1.4. *Effective EI is number listed times 10⁵ before adjustment for bending moment capacity. T-2 and T-10 through T-14 are restricted to 30 in. length at 4 in. wg, to 36 in. length at 3 in. wg and are not recommended for service above 4 in. wg. (+) indicates positive pressure use only.

Reinf. Class		T-2 Standing Drive Slip		T-10 Standing S		T-11 Standing S		T-12 Standing S		T-14 Standing S	
	EI*	H x T (mm)	KG LM	H x T (mm)	KG LM	H x T (mm)	KG LM	H x T (mm)	KG LM	H x T + HR (mm)	KG LM
A	0.12	Use B		Use B		12.7 x 0.55	0.74	Use B		Use D	
B	0.29	28.6 x 0.55	0.6	25 x 0.55	0.9	12.7 x 0.85 25 x 0.55	0.9	25 x 0.55	1.0	Use D	
C	0.55	28.6 x 0.85	0.9	25 x 0.85	1.2	25 x 0.85	1.2	25 x 0.70	1.2	Use D	
D	0.78	28.6 x 1.31	1.2	28.6 x 1.00 25 x 0.85 (+)	1.3	25 x 1.00 25 x 0.85 (+)	1.3	Use E	1.5	41.3 x 0.70 38.1 x 3.2 Bar	2.1
E	1.9	NOT GIVEN		28.6 x 1.31	1.5	25 x 1.31 (+)	1.3	25 x 1.31 38.1 x 1.00	1.8	Use F	
F	3.7			Use G		NOT GIVEN	NOT GIVEN	Use G		41.3 x 0.85 38.1 x 3.2 Bar	2.2
G	4.5			41.3 x 1.31	1.9			38.1 x 1.00	1.9	41.3 x 1.00 38.1 x 3.2 Bar	2.6
H	7.6			41.3 x 1.31 38.1 x 3.2 Bar	3.0						
I	20			54 x 1.00 51 x 51 x 3.2 Angle	4.3						
J	23			54 x 1.00 51 x 51 x 4.76 Angle	5.5						
K	30			NOT GIVEN							
L	60										

Table 2-31M Transverse Joint Reinforcement

See Section 2.1.4. *Effective EI is number listed times 10⁵ before adjustment for bending moment capacity. T-2 and T-10 through T-14 are restricted to 750 mm length at 1000 Pa, to 914 mm length at 750 Pa and are not recommended for service above 1000 Pa. (+) indicates positive pressure use only.




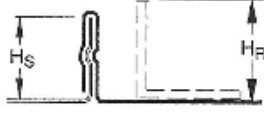
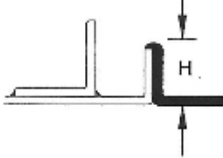
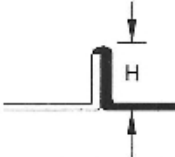
											
Mini- mum Rigidity Class	EI*	T-15 Standing Seam		Standing Seam or Welded Flange Reinforced						T-21 Welded Flange	
		26 to 22 ga Duct		20 to 16 ga Duct		20 to 16 ga Duct					
		H _S × T	WT LF	H _S	Angle H _R × T	WT LF	H _S	H _S × T (Min)	WT LF	H _S × T	WT LF
A	0.43	½ × 24 ga	0.2			1.0				½ × 22 ga	0.1
B	1.0	¾ × 24 ga	0.3			1.0				½ × 16 ga	0.2
C	1.9	Use D	0.5			1.0				¾ × 18 ga	0.3
D	2.7	¾ × 16 ga 1 × 20 ga	0.3	1"	1 × 1 × 16 ga	1.0				1¼ × 18 ga 1¼ × 22 ga (+)	0.4
E	6.5	1 × 16 ga	0.7	1"	1 × 1 × ⅝ or 1½ × 1½ × 16 ga	1.4	1"	1 × 1 × ⅝	1.0	1¼ × 16 ga 1½ × 20 ga (+)	0.5
F	12.8	1½ × 18 ga	0.8		Use G	1.8	1¼"	1¼ × 1¼ × 12 ga	1.7	1½ × 16 ga (+)	0.6
G	15.8	1½ × 18 ga(+)	0.8	1½"	1½ × 1½ × ⅝	2.0	1½"	1¼ × 1¼ × ⅝	2.4	See T-21a And Tie Rod Options	
H	26.4	See T-16 And Tie Rod Options		1½"	2 × 2 × ⅝	2.7	1½"	1½ × 1½ × ⅜	2.6		
I	69			1½"	2 × 2 × ⅜		1½"	2 × 2 × ⅜	2.7		
J	80				Use K	3.5	1½"	2 × 2 × ⅜	3.5		
K	103			1½"	2½ × 2½ × ⅜		1½"	2½ × 2½ × ⅜	4.1		
L	207				Not Given						

Table 2-33 Transverse Joint Reinforcement

See Section 2.1.4. *Effective EI is number listed times 10⁵ before adjustment for bending moment capacity. See tie rod options elsewhere. (+) indicates positive pressure use only.

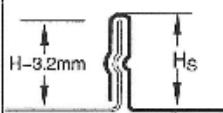

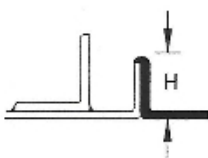
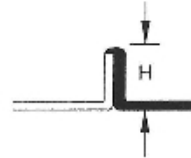
													
Mini- mum Rigidity Class	T-15 Standing Seam			Standing Seam or Welded Flange Reinforced						T-21 Welded Flange			
				0.55 to 0.85 mm Duct			1.00 to 1.61 mm Duct						
EI*	H _S × T (mm)	KG LM	H _S (mm)	Angle H _R × T	KG LM	H _S	H _S × T (Min) (mm)	KG LM	H _S × T (mm)	KG LM			
A	0.12	12.7 × 0.70	0.3						12.7 × 0.85	0.1			
B	0.29	19.1 × 0.70	0.4						19.1 × 1.61	0.3			
C	0.55	Use D	0.7						19.1 × 1.31	0.4			
D	0.78	19.1 × 1.61 25 × 1.0	0.4	25	25 × 25 × 1.61	1.5			31.8 × 1.31 31.8 × 0.85 (+)	0.6 0.4			
E	1.9	25 × 1.61	1.0	25	25 × 3.2	2.1	25	25 × 3.2	31.8 × 1.61 38.1 × 1.0 (+)	0.7			
F	3.7	38.1 × 1.31	1.2		Use G	2.7	31.8	31.8 × 2.8	38.1 × 1.61 (+)	0.9			
G	4.5	38.1 × 1.31 (+)	1.2	38.1	38.1 × 3.2	3.0	38.1	38.1 × 3.2	See T-21a And Tie Rod Options				
H	7.6	See T-16 And Tie Rod Options		38.1	51 × 3.2	4.0	38.1	38.1 × 4.8					
I	20			38.1	51 × 4.8		38.1	51 × 3.2					
J	23				Use K	5.2	38.1	51 × 4.8					
K	30			38.1	63.5 × 4.8		38.1	63.5 × 4.8					
L	60				Not Given								

Table 2-33M Transverse Joint Reinforcement

See Section 2.1.4. *Effective EI is number listed times 10⁵ before adjustment for bending moment capacity. See tie rod options elsewhere. (+) indicates positive pressure use only.



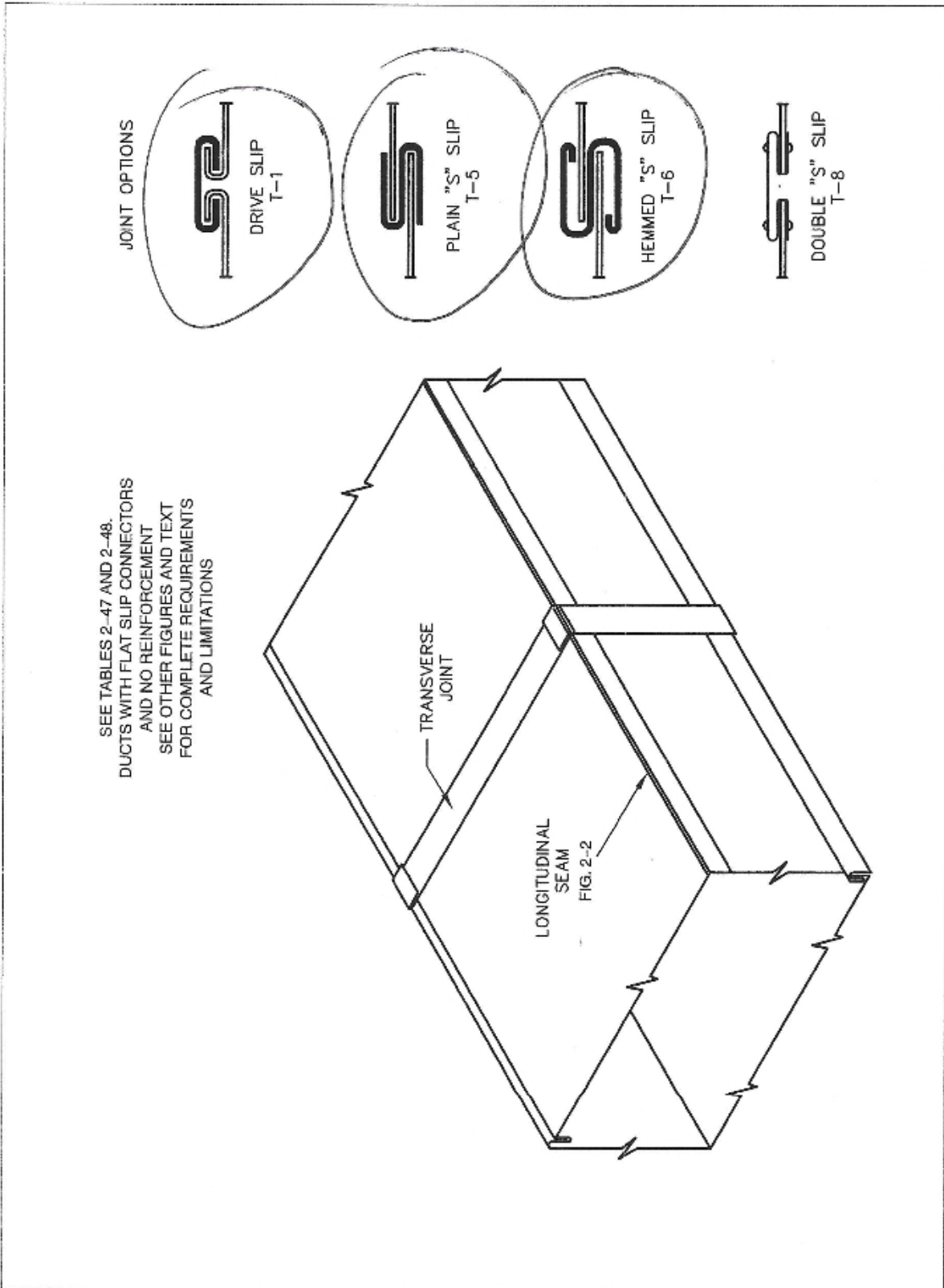


FIGURE 2-8 UNREINFORCED DUCT

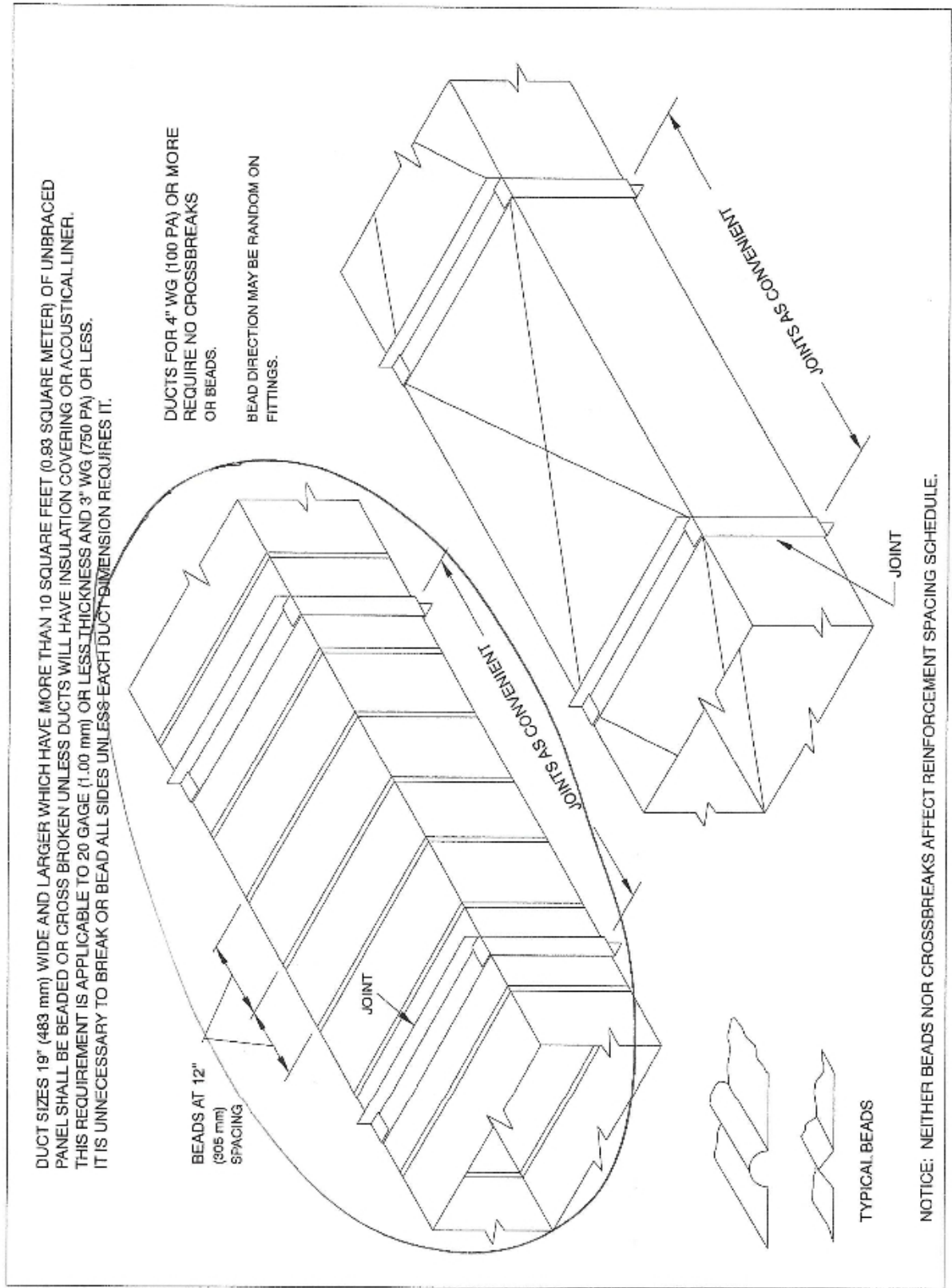


FIGURE 2-9 CROSSBROKEN AND BEADED DUCT



VANED ELBOW DETAILS

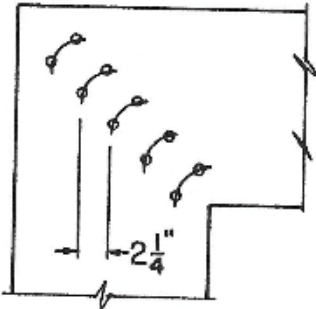
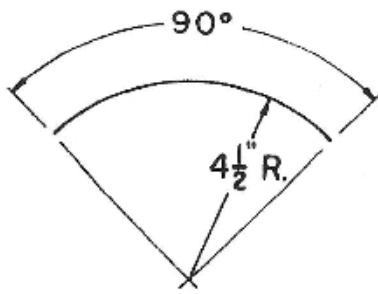
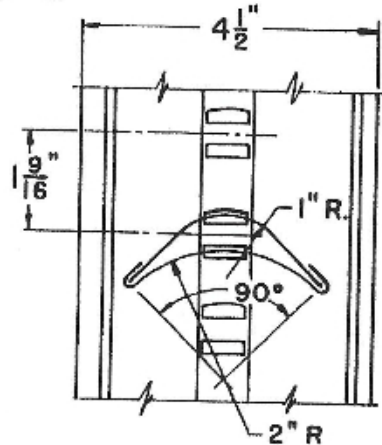


FIG. A
SINGLE VANE ELBOW



DETAIL 1
SINGLE VANE



DETAIL 2
RUNNER

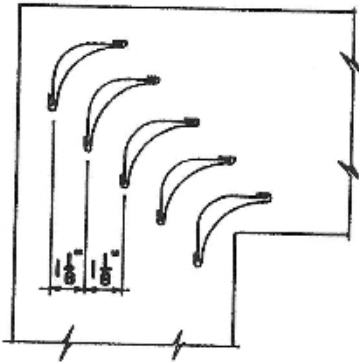
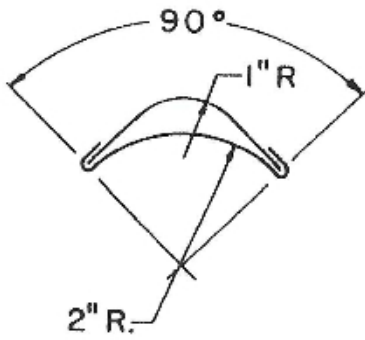
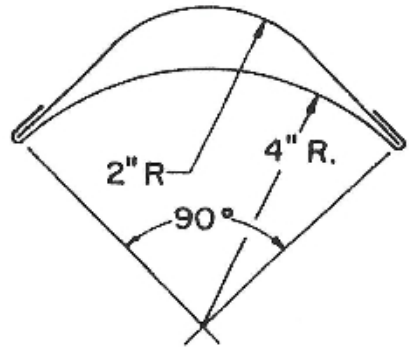


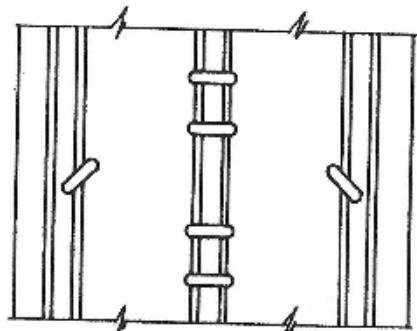
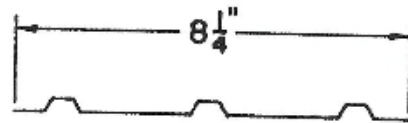
FIG. B
SMALL DOUBLE VANE
SQUARE ELBOW



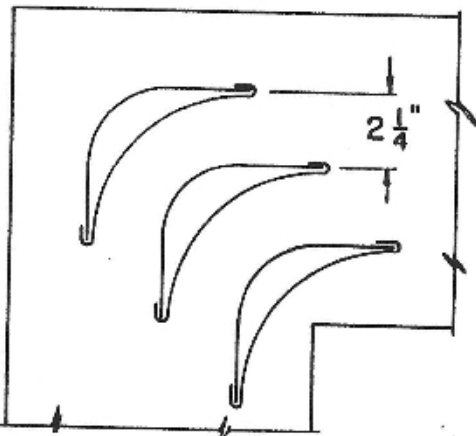
DETAIL 3
SMALL DOUBLE VANE



ALTERNATE DETAIL 4
LARGE DOUBLE VANE



ALTERNATE DETAIL 5
LARGE DOUBLE VANE RUNNER



ALTERNATE FIG. C
LARGE DOUBLE VANE
SQUARE ELBOW

SUBMITTAL

Product: Duct Sealant and Tape

Manufacturer: Hardcast, Inc.

Job Name: East End Elementary School

Location: Little Rock, AR

Date: January 24, 2024



OVERVIEW

Foil-Grip 1402 is a pressure-sensitive, 40-year cycle, duct joint and general purpose rolled mastic sealant. It provides an instant water-resistant air-tight grip to most surfaces including sheet metal, flex duct, and PVC-coated duct. Foil-Grip 1402 is suitable for subgrade application on PVC-coated duct and is ideal for replacement applications.

PART NUMBERS

304093	1 Case w/ (24) 2" x 100' Rolls (Non-printed)
304094	1 Case w/ (16) 3" x 100' Rolls (Non-printed)
304095	1 Case w/ (12) 4" x 100' Rolls (Non-printed)
304096	1 Case w/ (8) 6" x 100' Rolls (Non-printed)
304083	1 Roll 36" x 100' (Non-printed)
304099	1 Case w/ (24) 2" x 100' Rolls (Printed)
304100	1 Case w/ (16) 3" x 100' Rolls (Printed)

FEATURES AND BENEFITS

- Instant Adhesion
- Indoor/Outdoor
- True Zero VOC
- Metal & Subgrade PVC Ductwork
- All Pressure Classes Up To 20 inches W.C.
- 17-Mil Thickness

SPECIFICATIONS/STANDARDS COMPLIANCE

Property	Method	Results
Color	Visual	Mil Finish Aluminum Printed/Non-Printed With Gray Butyl Sealant
Backing	Visual	2 mils Aluminum
Thickness	ASTM D3652	17 mils nominal
Peel Strength	ASTM D3330-83	>10 lbs/linear inch
Tensile Strength	ASTM D412	955 psi avg.
Elongation	ASTM D412	500%
Flexibility	ASTM C765	Excellent/No Cracking
Water Resistance	CSTM. RA 8.0	Pass
VOC	EPA Method # 2	0 g/l
Flame	ASTM E84/UL 723	20
Smoke	ASTM E84/UL 723	40
Service Temperature	ASTM D2485/D2243	-20°F to 200°F (-28.8°C to 93.3°C)
Pressure Test	Independent 24 Hour Test up to 5/8-inch Diameter	20 inch w.c.
Weather Resistance	ASTM G53	Passes 2,000 QUV
Bond Time		Immediate/Full Bond: 15 Minutes
UL Rating	UL 723	Passes/Classified
VOC Limitation	SCAQMD Rule 1168	Pass
NFPA	90A & 90B	Class 1

STORAGE

Temperature	35°F to 110°F (1.7°C to 44°C) DO NOT FREEZE
Shelf Life	24 months
Flammability	Non-flammable



APPLICATION

Temperature	35°F to 110°F (1.7°C to 44°C)
Preparation	Surface must be dry and free of dirt, oil and grease.
Method	Cut desired length, peel off release liner, apply. Removal or repositioning may damage Foil-Grip 1402 and surface. Overlap at ends. Use squeegee with heavy pressure to assure complete contact.
Clean Up	UN-TACK™ or Solvent (Use safe handling practices.)
Painting	Use paint appropriate for aluminum



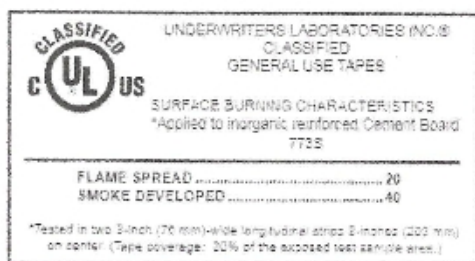
PRECAUTIONS

Surfaces must be clean and free of moisture and contamination. Do not apply this product in areas where temperatures will exceed 200°F. Keep out of the reach of children. DO NOT use where acidic or alkaline chemicals are present (i.e., lab fume hood, vents, etc.).

For Industrial Professional Use Only.

LEED

Post-industrial Recycled Content	0%
Pre-consumer Recycled Content	0%
VOC Content	0 g/L
Manufacturing Location(s)	Wylie, TX



CERTIFICATE OF COMPLIANCE



Hardcast, a Carlisle Company

CCWI-181 White Two Gallon Pail

113145-410

Certificate Number

04/30/2018 - 04/30/2023

Certificate Period

Certified

Status

UL 2818 - 2013 Standard for Chemical Emissions for Building Materials, Finishes and Furnishings

Building Construction Adhesives are determined compliant in accordance with an Office environment with an air change of 0.68 hr^{-1} .

Products tested in accordance with UL 2821 test method to show compliance to emission limits in UL 2818, Section 7.1.



GREENGUARD Certification Criteria for Building Products and Interior Finishes

Criteria	CAS Number	Maximum Allowable Predicted Concentration	Units
TVOC ^(A)	-	0.50	mg/m ³
Formaldehyde	50-00-0	61.3 (50 ppb)	µg/m ³
Total Aldehydes ^(B)	-	0.10	ppm
Particle Matter less than 10 µm ^(C)	-	50	µg/m ³
4-Phenylcyclohexene	4994-16-5	6.5	µg/m ³
Individual VOCs ^(D)	-	1/10th TLV	-

- (A) Defined to be the total response of measured VOCs falling within the C₆ – C₁₆ range, with responses calibrated to a toluene surrogate. Maximum allowable predicted TVOC concentrations for GREENGUARD (0.50 mg/m³) fall in the range of 0.5 mg/m³ or less, as specified in CDPH Standard Method v1.2.
- (B) The sum of all measured normal aldehydes from formaldehyde through nonanal, plus benzaldehyde, individually calibrated to a compound specific standard. Heptanal through nonanal are measured via TD/GC/MS analysis and the remaining aldehydes are measured using HPLC/UV analysis.
- (C) Particle emission requirement only applicable to HVAC Duct Products with exposed surface area in air streams (a forced air test with specific test method) and for wood finishing (sanding) systems.
- (D) Allowable levels for chemicals not listed are derived from 1/10th of the Threshold Limit Value (TLV) industrial work place standard (Reference: American Conference of Government Industrial Hygienists, 6500 Glenway, Building D-7, and Cincinnati, OH 45211-4438).



PART NUMBERS

304142	1 Case w/ (25) 11 oz. Cartridges (White)
304146	1 Case w/ (25) 11 oz. Cartridges (Gray)
304144	1 Case w/ (4) 1-Gallon Pails (White)
304148	1 Case w/ (4) 1-Gallon Pails (Gray)
304143	1 - 2-Gallon Pail (White)
304147	1 - 2-Gallon Pail (Gray)
304145	1 - 5-Gallon Pail (White)

TECHNICAL DATA

Color	White & Gray
Consistency	Heavy textured
Base	Synthetic latex
Solvent	Water
Weight per Gallon	11.6 lbs.
Solids Content	73.4%
Viscosity	Thixotropic
Coverage (UL 181 A-M)	Apply 18 mil, scrim, addt. 18 mil
Coverage (UL 181 B-M)	Approximately 214 to 320 lin. ft. per gal. at 20 to 30 mil wet film thickness at 3" width
Shore A Hardness	> 20
Flexibility	Passes ¼ inch mandrel bend
Time to Test	48 hours*
Service Temperature	-20°F to 200°F
Mildew Resistance	Mold & Mildew resistant
VOC	Exempt: 0 g/l Non Exempt: 38 g/l (less water)
Surface Burning	Flame Spread - 0, Smoke Developed - 0 (When tested in accordance with ASTM E84, UL 723)
Pressure Classes	SMACNA ½, 1, 2, 3, 4, 6 and 10 inches w.g.
Seal Class	Meets Seal Class A
Packaging	11 oz. cart.; 1, 2 & 5 gal. pails
Freeze/Thaw Stability	Passed 5 Cycles

*May vary according to temperature and humidity

SPECIFICATION/STANDARDS COMPLIANCE

Property	Method	Results
Freeze Thaw & Heat Cycling	ASTM C-731	Pass
Slump Test	ASTM D-2202	Pass
VOC Limitation	SCAQMD Rule 1168	Pass
	USDA	Pass
	FDA	Pass
	EPA	Pass
	City of Los Angeles Approval RR#8427	Pass

A versatile, all purpose duct sealant for use on all types of metal duct, fiberglass duct board, duct fabric and flex duct. CCWI-181 incorporates a built-in polyester reinforcement for exceptional strength, with UV inhibitors for outdoor use. UL 181A-M listed / UL 181B-M listed.


APPLICATION

Temperature	35°F to 110°F (1.7°C to 44°C)
Method	Brush, putty knife, caulk gun
Preparation	Surface must be dry, dirt, oil, and grease free.
Rate (UL 181 A-M)	Apply 18 mil, scrim and 18 mil over scrim.
Rate (UL 181 B-M)	Approx. 214 to 320 lin. ft. per gal. at 20 to 30 mil wet film thickness at 3" width.
Clean Up Wet	Soap and water
Clean Up Dry	UN-TACK™ or Solvent (Use safe handling practices.)
Painting	Only latex or epoxy paints
Ductboard	Scrim required for UL 181A-M

STORAGE

Temperature	35°F to 110°F (1.7°C to 44°C) DO NOT FREEZE
Shelf Life	One year (unopened)
Flammability	Non-flammable

Underwriters Laboratories Inc.®
LISTED
17NF
UL 181A-M
FOR USE WITH U.L. LISTED RIGID FIBERGLASS AIR DUCTS OR CONNECTORS.
UL 181B-M
FOR USE WITH U.L. LISTED FLEXIBLE AIR DUCTS OR CONNECTORS



PRECAUTIONS

Surface must be clean and free of moisture, contamination and foreign matter. Do not allow this product to freeze. Apply when temperatures will not fall below freezing for at least 36–48 hours, depending on temperature and humidity. Do not apply this product where temperatures will exceed 200°F. Keep out of the reach of children. Review MSDS for complete safety information prior to use. DO NOT use where acidic or alkaline chemicals are present (i.e., lab fume hood, vents, etc.)

For Industrial Professional Use Only.

SUBMITTAL

Product: Duct Liner

Manufacturer: Johns Manville

Job Name: East End Elementary School

Location: Little Rock, AR

Date: January 24, 2024

DESCRIPTION

Linacoustic® RC insulation is a flexible duct liner made from strong glass fibers bonded with a thermosetting resin. The airstream surface is protected with JM's exclusive Reinforced Coating system, which combines our state-of-the-art Permacote® acrylic coating with a flexible glass mat reinforcement to provide a smooth airstream surface.

FACTORY-APPLIED EDGE COATING

Edge coating is factory applied to the edges of the liner core, ensuring coverage of the leading edges per NAIMA/SMACNA requirements. Shop fabrication cuts may be coated with SuperSeal® edge treatment (refer to publication AHS-202).

USES

Linacoustic RC insulation is specifically designed for lining sheet metal ducts in air conditioning, heating and ventilating systems, providing superior acoustical and thermal performance.

STORAGE

Linacoustic RC should be kept clean and dry during storage, transport, fabrication, installation, and system operation.

GENERAL PROPERTIES

Operating temperature (max.) – ASTM C411	250°F (121°C)
Air velocity (max.) – ASTM C1071	6,000 fpm (30.5 m/sec)
Fungi resistance – ASTM C1338	Does not breed or promote
Fungi resistance – ASTM G21	No growth

STANDARD THICKNESSES AND PACKAGING

Thickness	Roll Length		Roll Widths for All Thicknesses*	
	in	mm	in	mm
½	13	100, 150, 200	34 to 72	864 to 1829
1	25	50, 100, 150, 200	34 to 72	864 to 1829
1½	38	50, 100	34 to 72	864 to 1829
2	51	50	34 to 72	864 to 1829
3	76.2	50	55 to 60	1422 to 1524

*Available in ½" (6.4 mm) increment.

Contact your Regional Sales Office for stock items and availability of special sizes.

SURFACE BURNING CHARACTERISTICS

Linacoustic RC duct liner meets the Surface Burning Characteristics and Limited Combustibility of the following standards:

- Standard/Test Method
- ASTM E84
- UL 723
- NFPA 255
- NFPA 90A and 90B
- NFPA 259
- CAN/ULC S102

Maximum Flame Spread Index	25
Maximum Smoke Developed Index	50



SPECIFICATION COMPLIANCE

- ASTM C1071, Type I
- ICC Compliant
- California Title 24
- MEA #353-93-M
- Conforms to ASHRAE 62
- SMACNA Application Standards for Duct Liners
- NAIMA Fibrous Glass Duct Liner Installation Standard
- Canada: CGSB 51-GP-11M and CAN/CGSB 51.11

ADVANTAGES

Improves Indoor Building Environment. Linacoustic RC duct liner improves indoor environmental quality by helping to control both temperature and sound.

Resistant to Dust and Dirt. The tough acrylic polymer Permacote coating helps guard against the incursion of dust or dirt into the substrate, minimizing the potential for biological growth.

Will Not Support Microbial Growth. Permacote coating is formulated with an immobilized EPA-registered protective agent to protect the coating from potential growth of fungi and bacteria.

Linacoustic RC duct liner meets all requirements for fungi and bacterial resistance. Tests were conducted in accordance with ASTM C1338 and ASTM G21 (fungi testing). Detailed information is available in Johns Manville fact sheet HSE-103FS.

Note: As with any type of surface, microbial growth may occur in accumulated duct system dirt, given certain conditions. This risk is minimized with proper design, filtration, maintenance and operation of the HVAC system.

Cleanability. If HVAC system cleaning is required, the Reinforced Coating airstream surface may be cleaned with industry-recognized dry methods. See the North American Insulation Manufacturers Association (NAIMA) "Cleaning Fibrous Glass Insulated Air Duct Systems."

Highly Resistant to Water. The reinforced coating surface provides superior resistance to penetration of incidental water into the fiber glass wool core.

LINACOUSTIC® RC

FIBERGLASS DUCT LINER WITH REINFORCED COATING SYSTEM

DATA SHEET

SUSTAINABLE BUILDING CERTIFICATIONS

GREENGUARD®
GREENGUARD® GOLD

Certified
Certified

GREENGUARD® Certified products have been screened for more than 10,000 volatile organic compounds (VOCs) and meet stringent standards for low chemical emissions based on established criteria from key public health agencies



INSTALLATION

Linacoustic RC duct liner installation must be performed in accordance with the requirements of the NAIMA Fibrous Glass Duct Liner Standards or SMACNA HVAC Duct Construction Standard. All transverse edges, or any edges exposed to airflow, must be coated with an approved duct liner coating material, such as Johns Manville SuperSeal products.

Minimizes Pre-installation Damage. Linacoustic RC duct liner's Reinforced Coating System is highly resistant to damage that can occur during in-shop handling, fabrication, jobsite shipping and installation.

Easy to Fabricate. Linacoustic RC duct liner is lightweight and easy to handle. Clean, even edges can be accurately cut with regular shop tools.

THERMAL PERFORMANCE

Thickness		R-value		Conductance	
in	mm	(hr•ft²•°F)/Btu	m²•°C/W	Btu/(hr•ft²•°F)	W/m²•°C
½	13	2.2	0.39	0.46	2.61
1	25	4.2	0.74	0.24	1.36
1½	38	6.3	1.11	0.16	0.91
2	51	8.0	1.41	0.13	0.74
3	76.2	12.0	2.11	0.08	0.47

R-value and conductance are calculated from the material thermal conductivity tested in accordance with ASTM C518 at 75°F (24°C) mean temperature.

SOUND ABSORPTION COEFFICIENTS (TYPE "A" MOUNTING)

Thickness		Sound Absorption Coefficient at Frequency (Cycles per Second) of						
in	mm	125	250	500	1000	2000	4000	NRC
½	13	0.07	0.20	0.44	0.66	0.84	0.93	0.55
1	25	0.08	0.31	0.64	0.84	0.97	1.03	0.70
1½	38	0.10	0.47	0.85	1.01	1.02	0.99	0.85
2	51	0.25	0.66	1.00	1.05	1.02	1.01	0.95
3	76.2	0.47	0.96	1.17	1.10	1.02	1.05	1.05

Coefficients were tested in accordance with ASTM C123 and ASTM E795.

ISO 9001:2015 CERTIFICATION

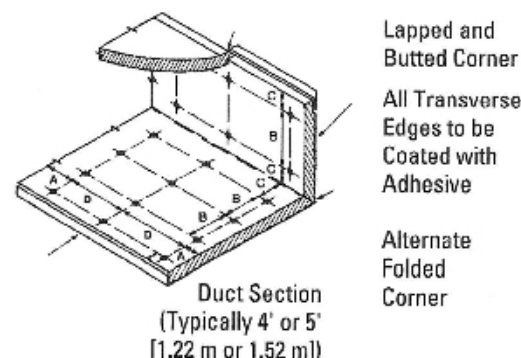
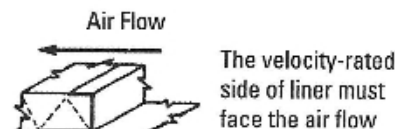
Johns Manville mechanical insulation products are designed, manufactured and tested in our own facilities, which are certified and registered to stringent ISO 9001:2015 (ANSI/ASQC 90) series quality standards. This certification, along with regular, independent third-party auditing for compliance, is your assurance that Johns Manville products deliver consistent high quality.

LINACOUSTIC® RC
FIBERGLASS DUCT LINER WITH REINFORCED COATING SYSTEM

DATA SHEET

DUCT LINER INSTALLATION

When velocity exceeds 4000 fpm (20.3 m/sec), use metal nosing on every leading edge. Nosing may be formed on duct or be channel or zee attached by screws, rivets or welds. A metal nosing shall also be installed at the fan discharge and at any point where lined duct is preceded by unlined duct.



Maximum spacing for fasteners. Actual intervals are approximate.

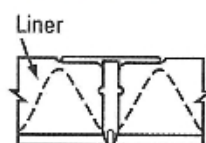
Velocity*	Dimensions							
	A		B		C		D	
	in	mm	in	mm	in	mm	in	mm
0-2500 fpm (0-12.7 m/sec)	3	76	12	305	4	102	18	457
2501-6000 fpm (12.7-30.5 m/sec)	3	76	6	152	4	102	16	406

*Unless a lower level is set by the listing agency.

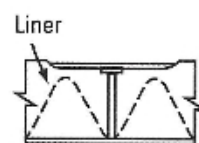
Liner adhered to the duct with 90% minimum area coverage of adhesive. Adhesive shall conform to ASTM C 916.

Shop or field cuts shall be liberally coated with SuperSeal Edge Treatment or approved adhesive.

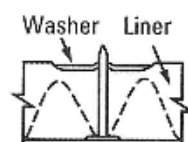
LINER FASTENERS



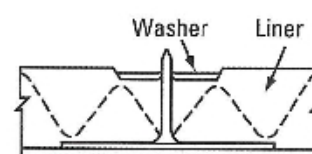
Type 1
Clinched Pin: Integral Head (Impact Applied)



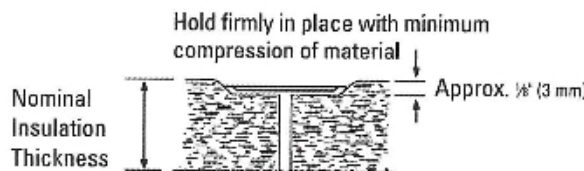
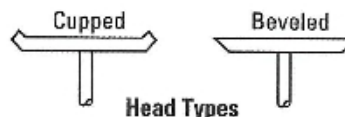
Type 2
Welded Pin: Integral Head



Type 3
Welded Pin: Press-on Head



Type 4
Adhered Pin: Press-on Head



717 17th St.
Denver, CO 80202
800-654-3103
www.JM.com

North American Sales Offices, Insulation Systems

Eastern Region & Canada
P.O. Box 158
Defiance, OH 43512
800-334-2399
Fax: 419-784-7866

Western Region & Outside North America
P.O. Box 5108
Denver, CO 80217
800-368-4431
Fax: 303-978-4661

Technical specifications as shown in this literature are intended to be used as general guidelines only. Please refer to the Safety Data Sheet and product label prior to using this product. The physical and chemical properties of Linacoustic RC listed herein represent typical, average values obtained in accordance with accepted test methods and are subject to normal manufacturing variations. They are supplied as a technical service and are subject to change without notice. Any references to numerical flame spread or smoke developed ratings are not intended to reflect hazards presented by these or any other materials under actual fire conditions.

All Johns Manville products are sold subject to Johns Manville's standard Terms and Conditions, which includes a Limited Warranty and Limitation of Remedy. For a copy of the Johns Manville standard Terms and Conditions or for information on other Johns Manville thermal insulation and systems, visit www.jm.com/terms-conditions or call (800) 654-3103.

SUBMITTAL

Product: Flexible Duct Connector

Manufacturer: DURO DYNE

Job Name: East End Elementary School

Location: Little Rock, AR

Date: January 24, 2024



Specifications

All Listed Duro Dyne Flexible Duct Connector Fabrics are designed to meet the following specifications:

1. MIL-C-20696B Para. 4.4.3. (Oil Resistance).
2. MIL-C-20696B Para. 4.4.4. (Hydro Carbon Resistance).
3. NFPA701 Tests for Flame Propagation of Fabrics and film (except Teflon).
4. California State Fire Marshal Approved.
5. Los Angeles City Approved. (*See note below)
6. Denver City Approved.

All Duro Dyne Flexible Duct Connectors utilize galvanized steel meeting ASTM-A-525 G 60 or better.

Duro Dyne Flexible Duct Connectors are also available with 300 series stainless steel or 3003 aluminum upon request.

**Note - Standard Excelcon is not LA city approved. Use Excelcon-LA when LA city approval is necessary. (See Submittal Form for Excelcon-LA)

CHEMICAL RESISTANCE

(X = Extremely Resistant)
 (NR = Not Recommended)
 (O = No Data Available)

Chemical	Excelcon	Neoprene	Durulon	Insulflex	Thermafab	Teflon	Glasscel	Chemical	Excelcon	Neoprene	Durulon	Insulflex	Thermafab	Teflon	Glasscel
Acetic Acid	NR	X	X	NR	NR	X	NR	Hydrofluoric Acid (100%)	NR	X	X	NR	NR	X	NR
Aluminum Chloride	X	X	X	X	X	X	X	Hydrogen Peroxide	X	NR	X	X	NR	NR	X
Aluminum Sulfate	X	X	X	X	X	X	X	Hydrogen Sulfide	X	X	X	X	O	X	X
Ammonia (Anhyd)	X	X	X	X	X	X	X	Lactic Acid	NR	X	X	NR	O	X	NR
Ammonium Hydroxide	X	X	X	X	X	X	X	Linseed Oil	NR	X	X	NR	X	O	NR
Ammonium Sulfate	X	X	X	X	X	X	X	Magnesium Chloride	NR	X	X	NR	NR	X	NR
Barium Sulfide	X	X	X	X	O	X	X	Maleic Acid	X	NR	X	X	X	O	X
Black Sulfate Liquor	X	X	X	X	NR	X	X	Methyl Alcohol	NR	X	X	NR	NR	X	NR
Boric Acid	X	X	X	X	X	X	X	Methyl Cellosolve	NR	X	X	NR	NR	O	NR
Butyl Alcohol	NR	X	X	NR	NR	X	NR	Mineral Oil	X	X	X	X	NR	X	X
Cadmium Plating Solution	X	NR	NR	NR	O	O	X	Naphtha	NR	NR	NR	NR	X	X	NR
Calcium Chloride	X	X	X	X	X	X	X	Nickel Chloride	X	X	X	X	O	X	X
Calcium Hypochlorite	X	NR	X	X	O	X	X	Nickel Sulfate	X	X	X	X	X	X	X
Chlorine Water	X	NR	NR	X	NR	O	X	Nitric Acid (40%)	X	NR	X	X	NR	X	X
Chromic Acid	X	NR	X	X	O	X	X	Oleic Acid	X	NR	NR	X	NR	X	X
Chromium Plating Solution	X	O	O	NR	O	O	X	Oleum	NR	NR	X	NR	O	X	NR
Citric Acid	X	X	X	X	X	X	X	Oxalic Acid	X	X	X	X	X	X	X
Copper Chloride	X	X	X	X	O	X	X	Phosphoric Acid (85%)	NR	X	X	NR	X	X	NR
Copper Sulfate	X	X	X	X	O	X	X	Pickling Solution	X	NR	X	X	O	O	X
Cottonseed Oil	X	X	X	X	X	O	X	Potassium Chloride	X	X	X	X	O	O	X
Diacetone Alcohol	NR	X	X	NR	O	O	NR	Potassium Cyanide	X	X	X	X	O	X	X
Disodium Phosphate	X	NR	NR	X	O	O	X	Potassium Dichromate	X	X	X	X	O	X	X
Ethyl Alcohol	NR	X	X	NR	NR	X	NR	Potassium Hydroxide (40%)	X	X	X	NR	X	X	X
Ethylene Glycol	NR	X	X	NR	X	X	NR	Potassium Sulfate	X	X	X	X	O	X	X
Ferric Chloride	X	X	X	X	X	X	X	Propyl Alcohol	NR	X	X	NR	NR	O	NR
Ferric Sulfate	X	X	X	X	X	X	X	Sodium Chloride	X	X	X	X	X	X	X
Fluoroboric Acid	X	X	X	NR	O	O	X	Sodium Hydroxide (40%)	NR	X	X	NR	X	X	NR
Formaldehyde (40%)	X	X	X	X	O	A	A	Sodium Hypochlorite	NR	NR	X	NR	NR	X	NR
Formic Acid	X	X	X	X	O	X	X	Steam	NR	X	NR	NR	O	X	NR
Glucose	X	X	X	X	X	X	X	Sulfur Dioxide (Liquid)	NR	X	X	NR	X	X	NR
Glycerine	NR	X	X	NR	X	X	NR	Sulfuric Acid (50%)	X	NR	X	NR	NR	X	X
Heptane	NR	X	X	NR	O	X	NR	Sulfuric Acid (over 50%)	NR	NR	X	NR	NR	X	NR
Hexane	NR	X	X	NR	O	X	NR	Tannic Acid	X	X	X	X	O	X	X
Hydrobromic Acid (40%)	NR	X	X	NR	O	X	NR	Vinegar	X	X	X	X	X	X	X
Hydrochloric Acid (conc)	NR	X	X	NR	NR	X	NR								

Duro Dyne East Division, Bay Shore, NY
 Duro Dyne Midwest Division, Hamilton, OH
 Duro Dyne West Division, Fontana, CA
 Duro Dyne Canada, Lachine, Quebec, Canada

631-249-9000 Fax: 631-249-8346
 513-870-6000 Fax: 513-870-6005
 562-926-1774 Fax: 562-926-5778
 514-422-9760 Fax: 514-636-0328

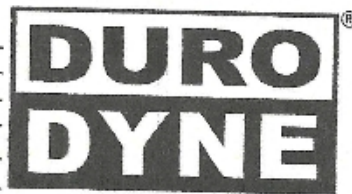
www.durodyne.com E-mail: durodyne@durodyne.com



©2019 Duro Dyne Corporation
 Printed in USA 3/29/19
 B0010403

SUBMITTAL RECORD

JOB _____
 LOCATION _____
 SUBMITTED TO _____
 SUBMITTAL PREPARED BY _____
 APPROVED BY _____
 DATE _____

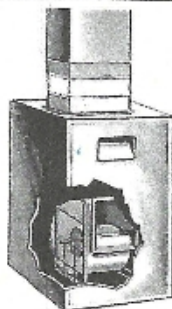


**Submittal Form
 DDFDC
 Flexible Duct Connector**

DESCRIPTION

All air duct installations for heating, cooling or ventilation are attached to mechanical equipment containing a fan or blower. Vibrations, noises and rattles resulting from operation of the fan or blower are transmitted into the metal ducts which carry the noises throughout the system.

In order to isolate the vibration and noises to the source, an air-tight flexible joint, consisting of a fabric which is attached to sheet metal on both sides, must be inserted between the equipment and the ductwork. This vibration isolator is called a "Flexible Duct Connector".



Fabric Comparisons	Excelon [®]	Neoprene (Specification Grade)	Durolon	Insulflex [®] *	Tetrafab [®]	Teflon	Glassteel
UL Classified Listing #	R4462	R4462	UL Certified NFPA 701	n/a	R4462	n/a	R4462
Continuous Temp. Range	-40°F. to 180°F.	-40°F. to 200°F.	-40°F. to 250°F.	-40°F. to 180°F.	-65°F. to 500°F.	-150°F. to 500°F.	-40°F. to 180°F.
Color	Black	Black	White	Black	Grey	Grey Outside/Beige Inside	Grey & Black
Commercial Grade Weight	22 oz.	30 oz.	26 oz.	28 oz. (composite weight)	17 oz.	16.5 oz.	16 oz.
Residential Grade Weight	17 oz.	30 oz.	26 oz.	28 oz. (composite weight)	17 oz.	16.5 oz.	16 oz.
Abrasion Resistance ¹	15,000 cycles	600 cycles	500 cycles	500 cycles	125 cycles	1,000 cycles	1,400 cycles
Leakage Resistance ²	350	595	250	125	400	650	120
Tear Strength ¹	100 lbs. / 100 lbs.	12 lbs. / 12 lbs.	12 lbs. / 12 lbs.	8 lbs. / 11 lbs.	50 lbs. / 40 lbs.	50 lbs. / 30 lbs.	8 lbs. / 9 lbs.
Tensile Strength ⁴	240 lbs. / 220 lbs.	500 lbs. / 450 lbs.	225 lbs. / 300 lbs.	70 lbs. / 70 lbs.	200 lbs. / 150 lbs.	400 lbs. / 300 lbs.	90 lbs. / 90 lbs.
ASTM E84 Rating (Flame/Smoke)	10/250	10/55	10/120	N/A	0/25	0/5	N/A
NFPA 701	yes	yes	yes	N/A	yes	no	N/A
Base Fabric	Woven Nylon/Polyester Blend	Woven Fiberglass	Woven Fiberglass	Polyester	Woven Fiberglass	Fiberglass/Satin Weave	Woven Fiberglass
Coating	Vinyl	Neoprene	Hypalon	Vinyl	Silicon Rubber	Teflon	Vinyl
Features	<ul style="list-style-type: none"> • Excellent water resistance • Excellent tear strength • Excellent all purpose fabric • Unaffected by mildew 	<ul style="list-style-type: none"> • Extremely resistant to alkalis & gasoline • Excellent on systems exposed to toxic fumes • Good general purpose fabric • Unaffected by mildew 	<ul style="list-style-type: none"> • Excellent ozone & weathering resistance • Best overall acid resistance • Recommended for rooftop applications • Unaffected by mildew 	<ul style="list-style-type: none"> • Low Smoke Emission • Insulated 3-4-3 Configuration 	<ul style="list-style-type: none"> • Excellent high temp. & chemical resistance • Extremely low smoke emission • Unaffected by mildew 	<ul style="list-style-type: none"> • High temperature resistant • High corrosion resistance • Excellent chemical resistance 	<ul style="list-style-type: none"> • Good, low cost • Resistant to acids & chemical fumes • Resistant to grease & alkalis • Unaffected by mildew
Metal-Fab [®] Grip Loc	MBX333 (#10159)	MFN333 (#10003)	MFD333 (#10002)	IDC343 (#10173) *Gauge: 28 +Guard Loc	MFT333 (#10005)	MCT333 (#10278)	MGL333 (#10004)
Super Metal-Fab [®] Grip Loc	MB6X363 (#10160) MB12X3123 (#10252)	MF6N363 (#10012) MFN12N3123 (#10251)	MF6D363 (#10011)	Not Available	MF6T363 (#10013)	Not Available	MF6G363 (#10016)
TDC/TDF Grip Loc	MBX444 (#10210) MBX464 (#10214) MBX484 (#10280) MBX4104 (#10286)	MFN444 (#10211) MFN464 (#10246) MFN484 (#10281) MFN4124 (#10254)	MFD444 (#10237) MFD464 (#10245)	Not Available	Not Available	MCT444 (#10279) MCT4104 (#10287)	Not Available

All Metal-Fab, Super Metal-Fab and TDC/TDF Flexible Duct Connectors are manufactured with 24 gauge galvanized steel. Duro Dyne meets or exceeds the SMACNA steel requirements for flexible duct connector. Other materials are available upon request.

Notes:

1. Abrasion resistance as per Federal Test Standard 191 Method #5306 using CS 17 wheel with 250 Gram load.
2. Leakage resistance as per Federal Test Standard 191 Method #5512. Results in P.S.I. (To convert inches of water multiply P.S.I. x 27.176.)
3. Tear strength in tongue pounds as per Federal Test Standard 191 Method #5134.1 (warp/fill).
4. Tensile strength in grab pounds as per Federal Test Standard 191 Method #5100 (warp/fill).
5. Standard Excelon is not LA city approved. Use Excelon-LA when LA city approval is necessary. (See Specification Form Excelon-LA - 203)

All Duro Dyne Flexible Duct Connector Products are suitable for pressures of -10 to +15 wg. Duro Dyne's standard "single fold" metal to fabric grip has been tested by an independent testing laboratory to withstand a negative pressure of -10" WC and a positive pressure of +17.25" WC with no tearing or visible separation.

SUGGESTED SPECIFICATION

Vibration Isolating Flexible Duct Connector For Heating, Cooling & Exhaust Supplies & Returns.

At the inlet and discharge of all air handling equipment (unless otherwise noted) furnish and install vibration isolators. Vibration isolators shall be a coated woven fabric named _____ and shall be "Underviters Laboratories Classified". Vibration isolators shall have a tear strength of not less than _____, and a continuous temperature range of _____. Vibration isolators shall be preassembled metal to exposed fabric to metal. Fabric and metal shall be joined by means of a double lock seam. Vibration isolators shall be code _____

(called Flexible Duct Connectors) as manufactured by Duro Dyne Corporation, Bay Shore, N.Y.