



*Quality People. Building Solutions.*

Comfort Systems USA (Arkansas), Inc.  
P.O. Box 16620  
LittleRock, AR 72231  
Phone 501-834-3320  
Fax 501-834-5416

**Date:** 6/18/2024  
**Return Request:** ASAP  
**Project:** Hugg and Hall Storage Addition  
**Supplier:** CSUSA  
**Manufacturer:**  
**Submittal:** EF-01 & 02 Exhaust Fans  
**Submittal Number:**  
**Spec Section:** None  
**Drawing # and Installation Location:** M5.0

**ARCHITECT**

Fennell / Purifoy Architects  
100 River Bluff Dr Suite 320  
Little Rock, Arkansas 72202  
(501) 372-6734

**CONSTRUCTION MANAGER**

Kinco Constructors  
12600 Lawson Road  
Little Rock, Arkansas 72210  
(501) 225-7606

**ENGINEER**

Brown Engineers  
17200 Chenal Pkwy Suite 300  
Little Rock, Arkansas 72223  
(501) 448-0100

**MECHANICAL SUBCONTRACTOR**

Comfort Systems USA (Arkansas), Inc.  
9924 Landers Road  
North Little Rock, Arkansas 72117  
(501) 834-3320

**Comments:**

**CSUSA PROJECT NO.**  
**24-1051**  
[jon@comfortar.com](mailto:jon@comfortar.com)

9924 Landers Road  
No. LittleRock, AR 72117



# IOM

## Hugg and Hall Mobile Storage

**Powers of Arkansas  
5440 Northshore Drive  
North Little Rock, AR 72118**



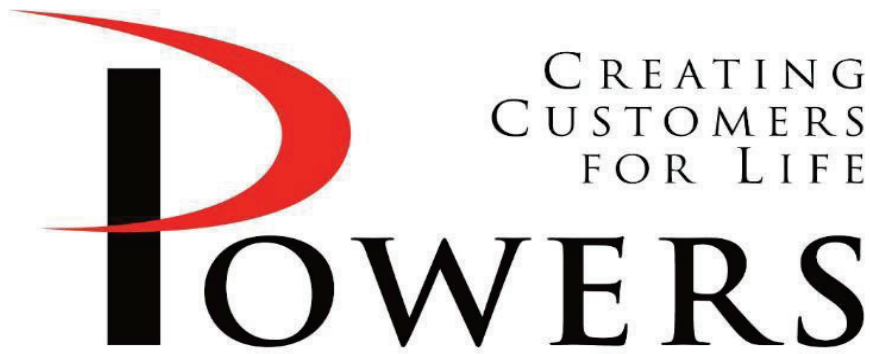

## IOM

<b>PRODUCT</b>	Exhaust Fans EF-01,02
<b>MANUFACTURER</b>	Loren Cook
<b>JOB NAME</b>	Hugg and Hall Mobile Storage
<b>LOCATION</b>	Little Rock, AR
<b>ENGINEER</b>	Brown Engineers
<b>CONTRACTOR</b>	Comfort Systems
<b>DATE</b>	10/3/2024
<b>SUBMITTED BY</b>	Todd Given

5440 Northshore Drive - North Little Rock, Arkansas 72118 - Tel: 501.374.5420 Fax: 501.370.9298

This publication contains the installation, operation and maintenance instructions for standard units of the *Gemini: Ceiling and Cabinet Fans*.



**Carefully read this publication and any supplemental documents prior to any installation or maintenance procedure.**

Loren Cook catalog, *Gemini*, provides additional information describing the equipment, fan performance, available accessories and specification data.

For additional safety information, refer to AMCA Publication 410-96, *Safety Practices for Users and Installers of Industrial and Commercial Fans*.

All of the publications listed above can be obtained from:

- [lorencook.com](http://lorencook.com)
- [info@lorencook.com](mailto:info@lorencook.com)
- 417-869-6474 ext. 166

For information and instructions on special equipment, contact Loren Cook Company at 417-869-6474.

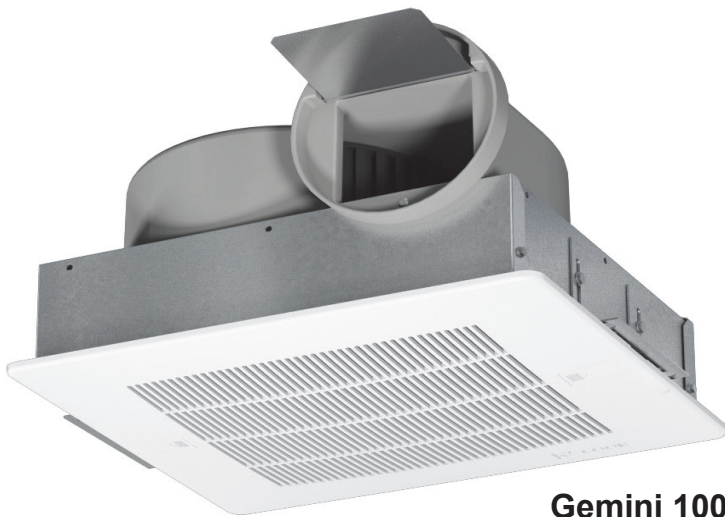

**Gemini 100**

### Receiving and Inspection

Carefully inspect the fan and accessories for any damage and shortage immediately upon receipt of fan.

- Turn the wheel by hand to ensure it turns freely and does not bind.
- Inspect dampers (if included) for free operation of all moving parts.
- Remove mounting brackets from packing insert & install mounting brackets (Gemini 100 only).
- Remove shipping tape.
- Record on the Delivery Receipt any visible sign of damage.

### Handling

Lift fan by grasping the outside housing (cabinet) or by the blower mounting brace. Never lift by the shaft or motor.

## **!WARNING**

### Rotating Parts & Electrical Shock Hazard:

Fans should be installed and serviced by qualified personnel only.

Disconnect electric power before working on unit (prior to removal of guards or entry into access doors).

Follow proper lockout/tagout procedures to ensure the unit cannot be energized while being installed or serviced.

A disconnect switch should be placed near the fan, so power can be swiftly turned off in case of an emergency. This will also allow maintenance personnel to have complete control of the power source.

Grounding is required. All field-installed wiring must be completed by qualified personnel. All field installed wiring must comply with National Electric Code (NFPA 70) and all applicable local codes.

Fans and blowers create pressure at the discharge and vacuum at the inlet. This may cause objects to get pulled into the unit and objects to be propelled rapidly from the discharge. The discharge should always be directed in a safe direction and inlets should not be left unguarded. Any object pulled into the inlet will become a projectile capable of causing serious injury or death.

When air is allowed to move through a non-powered fan, the impeller can rotate. This is referred to as windmilling. This unexpected rotation of components can cause a hazardous condition. Impellers should be blocked in position or air passages blocked to prevent draft prior to working on fans.

Friction and power loss inside rotating components can cause them to be a potential burn hazard. All components should be approached with caution and/or allowed to cool before contacting them for maintenance.

Under certain lighting conditions, rotating components may appear stationary. Components should be verified to be stationary in a safe manner, before they come into contact with personnel, tools or clothing.

Failure to follow these instructions could result in death or serious injury.

## Storage

If the fan is stored for any length of time prior to installation, store it in its original shipping crate and protect it from dust, debris and the weather.

## Installation

### Motor Installation

All Gemini units are shipped with motors mounted at the factory.

### Gemini 100 Inline to Ceiling Conversion

The Gemini 100 series can be converted from inline to ceiling by ordering the Inline to Ceiling Conversion Kit from Loren Cook Company (Part Number 797180). The kit includes all parts required, plus detail instructions on how to convert the Gemini 100.

### Gemini 100 Ceiling to Inline Conversion

The Gemini 100 series can be field converted from ceiling to inline by following these steps:

1. Remove and discard the inlet box end plate.
2. Install the inline cover panel with sheet metal screws as shown on the following page. Ceiling to Inline Conversion Kit can be ordered from Loren Cook Company (Part Number 797181), or fabricate the required part using the following two sketches.

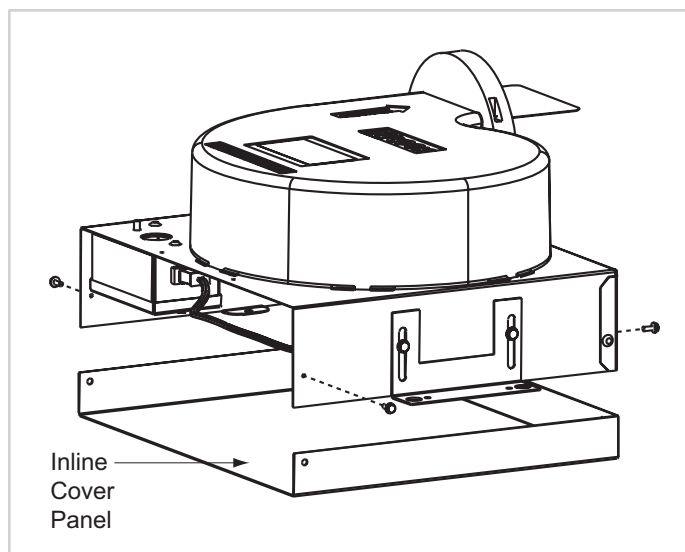
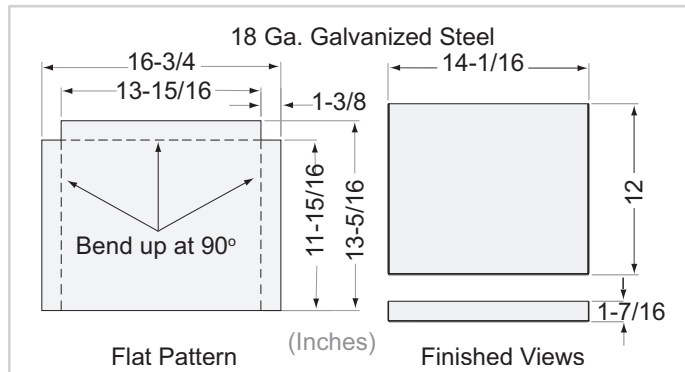

### Direction of Discharge (200–900 Series)

Discharge direction can be converted from right angle to straight line, without a kit, by swapping outer panel and the inlet/grille: See *Figure 1*.

1. Remove the side panel, mounting brackets (2) and grille (if present).
2. Place the side panel where the inlet/grille had been. Place the mounting brackets on the edge where the side panel had been. Holes are pre-punched for this procedure.
3. Rotate unit so that the outlet is on top.

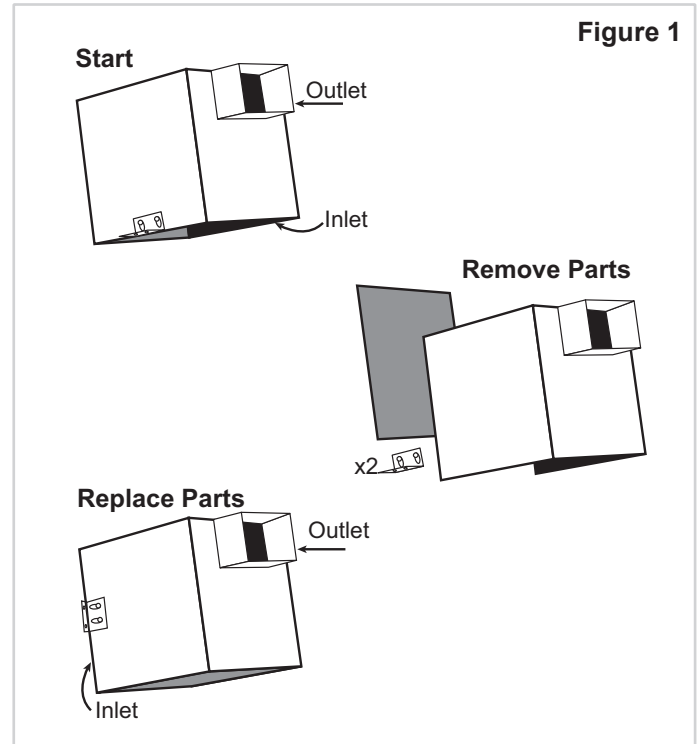

### Fan Installation

1. Use the mounting bracket slots to lower the unit housing by a distance equal to the ceiling thickness. Refer to *Figure 2*.
2. Raise the unit, as needed to accommodate accessories and options: With optional filter, raise unit 3/8". For both filter and deluxe aluminum grille options, raise unit 7/8" to compensate for 1/2" grate protrusion of grille. If filter is not present: the grate on the aluminum grille will fit inside of the unit (except sizes 160 & 180). Other grilles have no protrusion and fit flush with the fan.
3. Fasten duct work to the outside of the duct collar (damper frame) using sheet metal screws and foil tape. Make sure sheet metal screws are placed where they do not interfere with damper operation.
4. Fasten the housing to the bottom of the joists through the holes provided in the mounting bracket.



**For Ceiling Radiation Damper Installation see separate document, "Gemini/CRD Installation Supplement."**

## Typical Installation

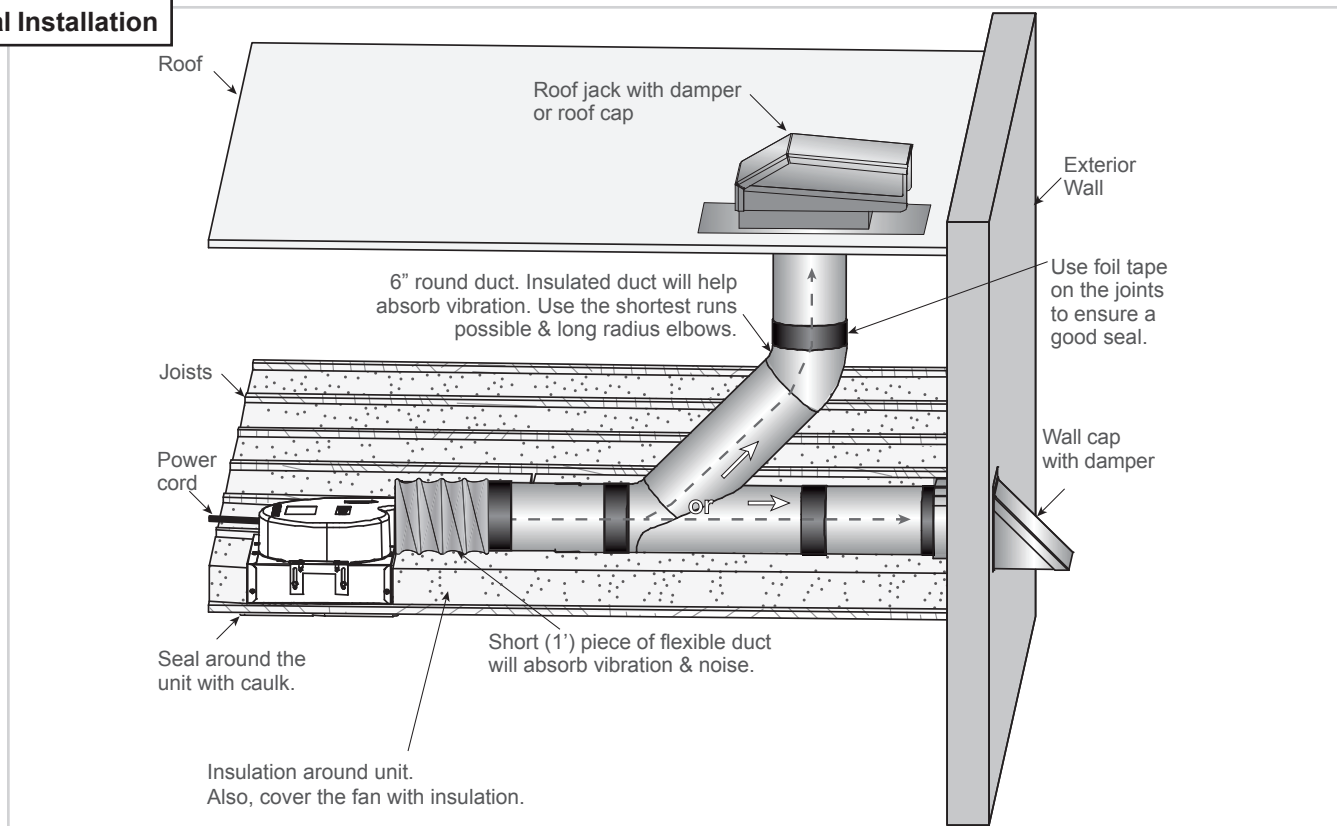
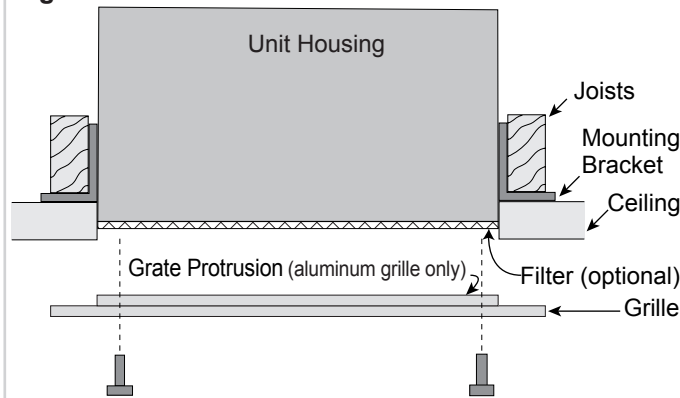
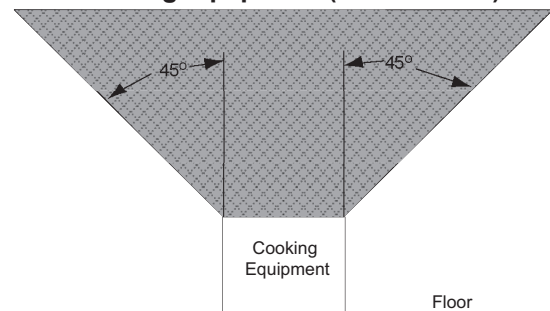

Figure 2



**Notice! Do not install above or around cooking equipment (shaded area)**



## Wiring Installation

All wiring should be in accordance with local ordinances and the National Electrical Code, NFPA 70.

Ensure the power supply (voltage, frequency and current carrying capacity of wires) is in accordance with the motor nameplate. Refer to *Wiring Diagrams*.

Lock out all power sources before unit is wired to power

**Follow the wiring diagram in the disconnect switch and the wiring diagram provided with the motor. Correctly label the circuit on the main power box and always identify a closed switch to promote safety (i.e., red tape over a closed switch).**

Note: Insulate Unused Leads. Fan plug box is designed for single speed operation, using an FSC to vary speed if required. Do not wire to more than two leads.

## Wiring Diagrams

### ⚠ WARNING

#### Electrical Shock & Fire Hazard:

- Insulate Unused Leads Separately
- Failure to follow these instructions could result in death or serious injury.

#### Gemini 100 with Vari-Flow® EC Motor:

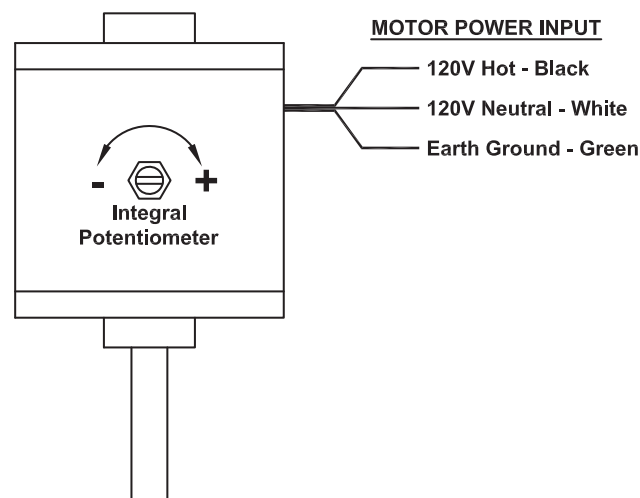

**Gemini 300 - 900 with Vari-Flow® EC Motor**

See EC motor wiring supplement.

**Gemini 100 Series:**

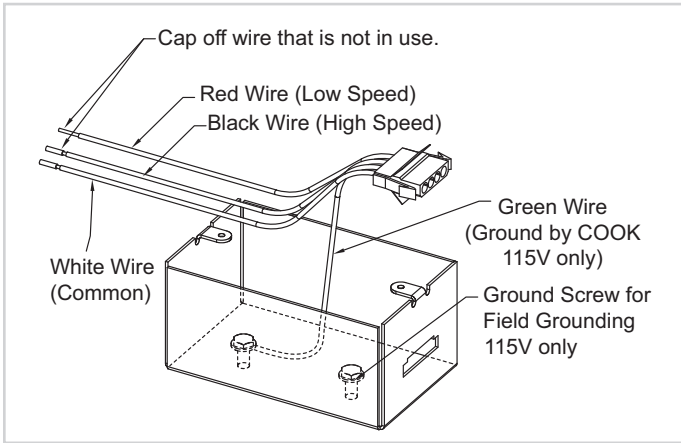

For fan power supply connection use 4-wire(115V) or 3 wire(220V) cable provided in field wiring box shown on above diagram.

For 115V connect field ground wire to green ground screw located inside fan electrical box. Connect one supply line to white wire. Depending on fan speed requirements connect other supply line to Red wire for Low Speed or Black wire for High Speed. Insulate unused Red or Black wire. Replace electrical box cover. Model 126, 146, 166, 186 are Low Speed. Models 128, 148, 168, 188 are High Speed.

**Gemini 200, 300, 500, 600 and 700 Series:**

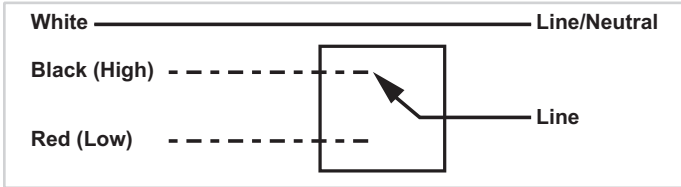

**Gemini 400 Series:**



**Gemini 800 - 900 Series:**

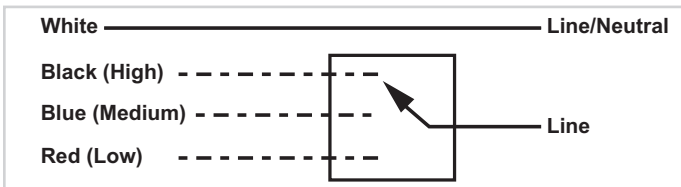

**Gemini 1000:**

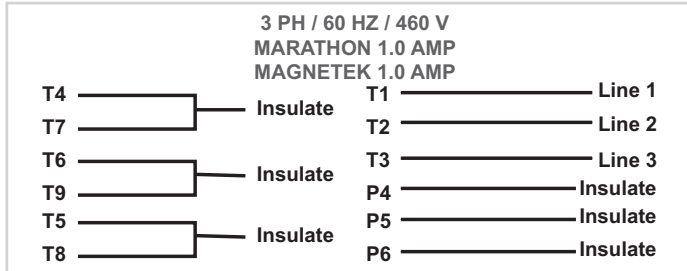
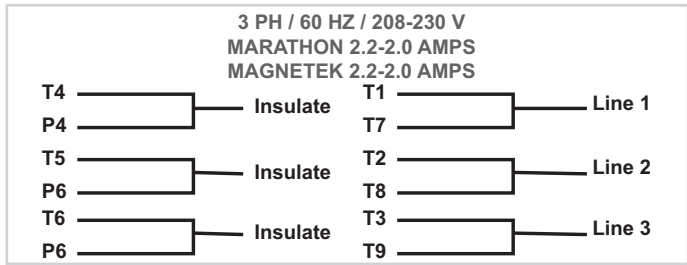
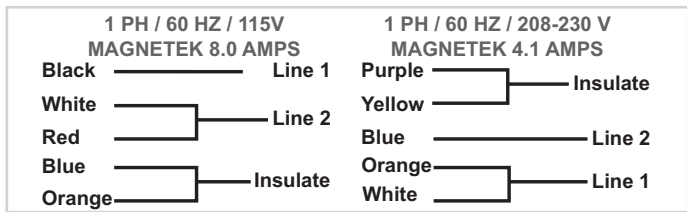
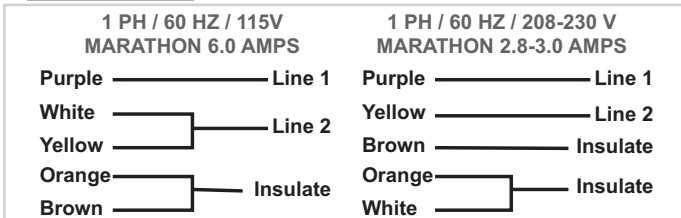

**Gemini 2000:**

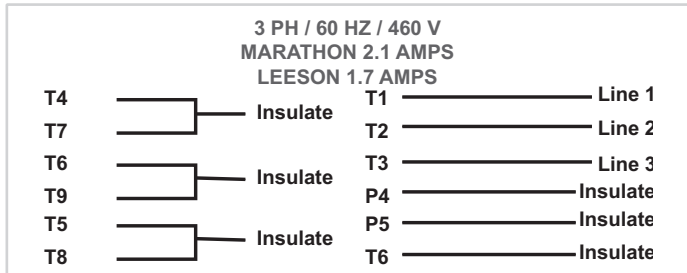
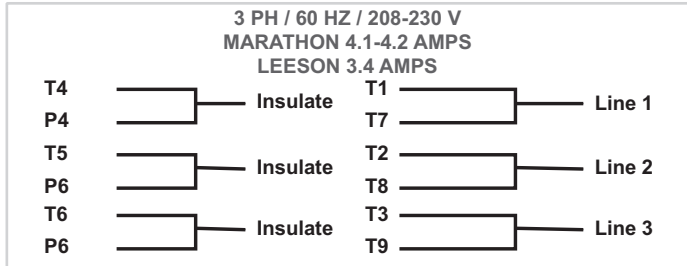
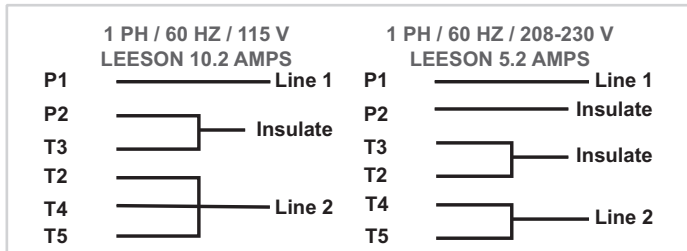
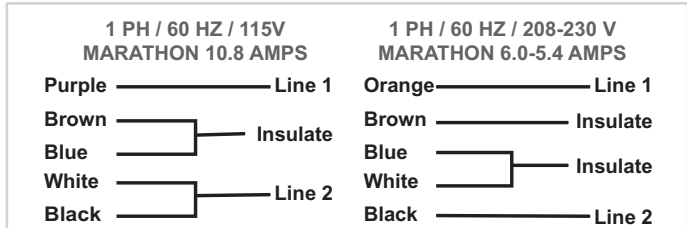



## FSC:

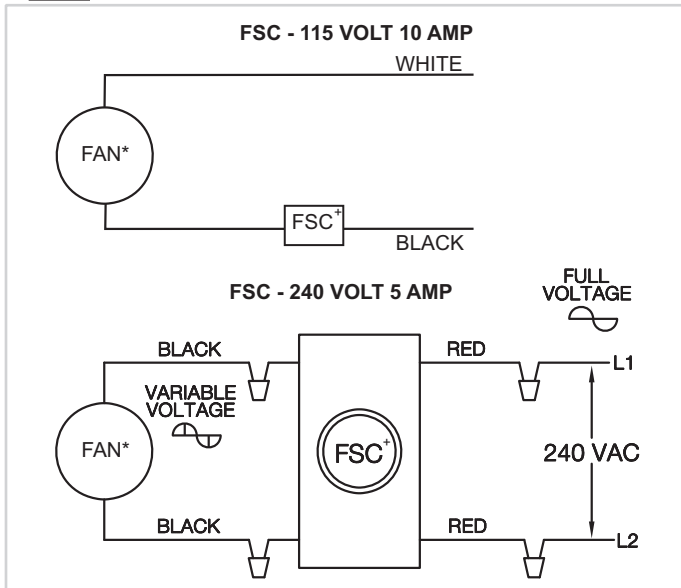

## Time Delay Switch:

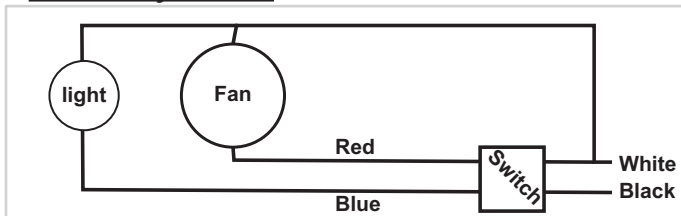

## Final Installation Steps

1. Inspect fasteners and setscrews (particularly fan mounting fasteners) and tighten as required.
2. Inspect for correct amperage and voltage with an ammeter and voltmeter.
3. Ensure blower is secured to duct work.
4. Ensure all accessories are installed.
5. Inspect wheel-to-inlet clearance. Make sure wheel does not rub against the inlet.
6. Test the fan to be sure the rotation is the same as indicated by the arrow marked *Rotation*.

Grille installation is described after the operation and inspection sections.

## Operation

### Pre-Start Checks

1. Lock out all the primary and secondary power sources.
2. Inspect fasteners and setscrews (particularly those used for mounting the fan) and tighten if necessary.
3. Inspect motor wiring.
4. Ensure fan and ductwork are clean and free of debris.
5. Test the fan to ensure the rotation of the wheel is the same as indicated by the rotation label.
6. Restore power to unit.

## Start Up

Before attaching the grille, turn the fan on and inspect for the following:

- Direction of rotation.
- Excessive vibration.
- Unusual noise.
- Motor noise.
- Improper motor amperage or voltage.

Lock out all electrical power and check for the cause of the trouble—refer to the *Troubleshooting* section.

## Inspection

Inspection of the fan should be conducted at the first 30 minute interval of satisfactory operation. During the inspection, stop the fan and inspect as per directions below.

- Inspect bolts, setscrews and motor mounting bolts.
- Adjust and tighten as necessary.

## Grille Installation

Attach the grille by hand-tightening the grille screws. When the unit is furnished with a filter, place the screws through the hole in the grille. Install the filter through the holes provided in the filter frame. See *Figure 2*.

## Maintenance

Establish a schedule for inspecting all parts of the fan. The frequency of inspection depends on the operating conditions and location of the fan.

Fans exhausting contaminated air (airborne abrasives) should be inspected every three months.

Regular inspections are recommended for fans exhausting non-contaminated air. **It is recommended the following inspections be conducted twice per year:**

- Inspect bolts and setscrews for tightness. Tighten as necessary.
- Inspect for cleanliness. Clean exterior surfaces only. Removing dust and grease on motor housing assures proper motor cooling.

## Access

### Gemini 100:

To inspect, clean or repair, refer to the following diagram and follow these steps:

1. Remove grille.
2. Remove blower assembly from housing:
  1. Disconnect the motor from electrical supply
  2. Remove the mounting bolts on the inlet plate assembly and remove the motor/wheel assembly
3. Remove the blower wheel with an allen wrench

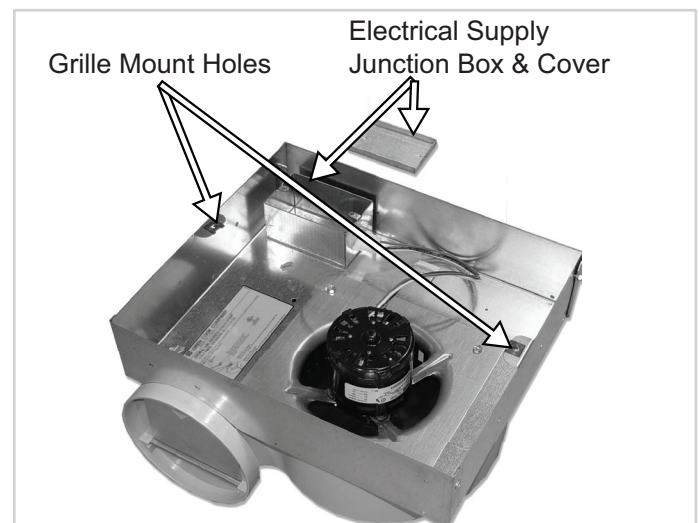

## Gemini 200 - 700 series

To inspect, clean, or repair, refer to the follow diagram and follow these steps:

1. Remove grille.
2. Remove blower assembly from housing:
  - a. Disconnect the motor from electrical supply.
  - b. Remove mounting bolts.
  - c. Slide discharge flange out of spring clip and move motor/blower assembly from box.
3. Remove inlet ring from blower housing.
4. Remove blower wheel with an allen wrench.

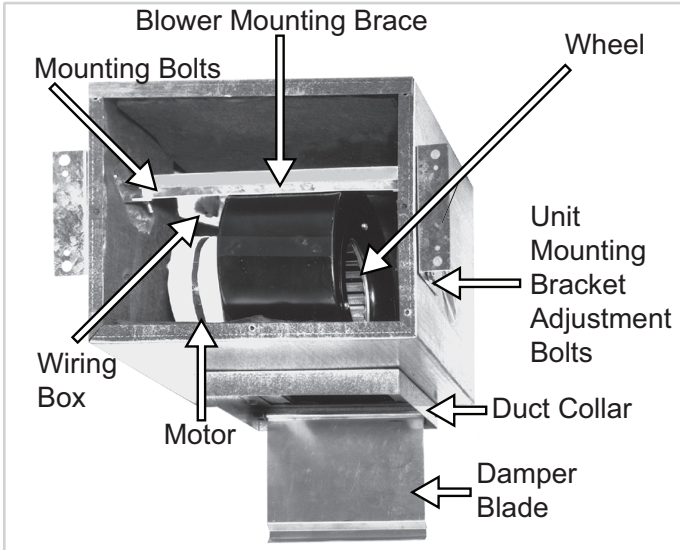

## Gemini 800 - 2000 series:

To inspect, clean, or repair, refer to the diagram below and follow these steps:

1. Remove grille.
2. Remove blower assembly from housing:
  - a. Disconnect the motor from the electrical supply.
  - b. Remove motor plate bolts.
  - c. Slide motor plate and remove motor/blower assembly from box.
3. Remove inlet rings from blower housing (both sides).
4. Mark the wheel and housing to ensure correct replacement of blower wheels (one is clockwise and the other is counter-clockwise), then remove the blower wheels with an allen wrench.

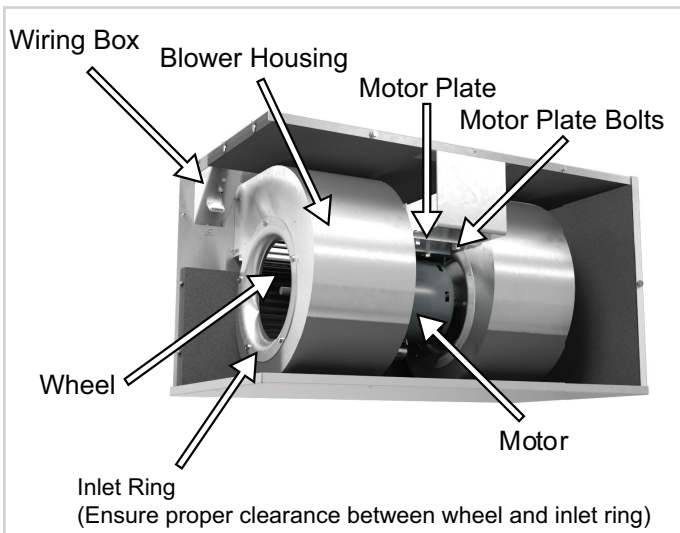

## **Reassembly**

Simply reverse the disassembly instructions. Make sure the wheel rotates in the same direction as the arrow on the blower housing. Make sure the wheels do not rub on the inlet rings. When replacing the motor, make sure the motor and wheels are properly aligned with the blower housing.

**Notice! Ensure that the blower discharge flange is secured in slot of the cabinet on Gemini 200 - 700 series.**

## **Motor Bearings**

Motor bearings are pre-lubricated and sealed. Under normal conditions they will not require further maintenance for a period of ten years.

## **Motor Services**

Should the motor prove defective within a one-year period, contact your local Loren Cook representative or your nearest authorized electric motor service representative

## **Troubleshooting**

### **Problem and Potential Cause**

#### **Low Capacity or Pressure:**

- Incorrect direction of rotation. Make sure the fan rotates in same direction as the arrows on the motor or belt drive assembly.
- Poor fan inlet conditions. There should be a straight clear duct at the inlet.
- Improper wheel alignment.
- Damper held shut by tape.
- Screw attaching duct work to collar interfering with damper operation.

#### **Excessive Vibration and Noise:**

- Damaged or unbalanced wheel.
- Belts too loose; worn or oily belts.
- Speed too high.
- Incorrect direction of rotation. Make sure the fan rotates in same direction as the arrows on the motor or belt drive assembly.
- Bearings need lubrication or replacement.
- Fan surge.

#### **Overheated Motor:**

- Motor improperly wired.
- Incorrect direction of rotation. Make sure the fan rotates in same direction as the arrows on the motor or belt drive assembly.
- Cooling air diverted or blocked.
- Improper inlet clearance.
- Incorrect fan RPMs.
- Incorrect voltage.

## Gemini 100 Parts List

Part No.	Part Description
1	Inlet Box End Plate (Ceiling only)
2	Housing/Scroll
3	Field Wiring Compartment
4	Motor
5	Tinnerman Clip (Grill) X2
6	Mounting Bracket
7	Backdraft Damper
8	Wheel
9	Motor Mount/Inlet
10	Inlet Box
11	Grille

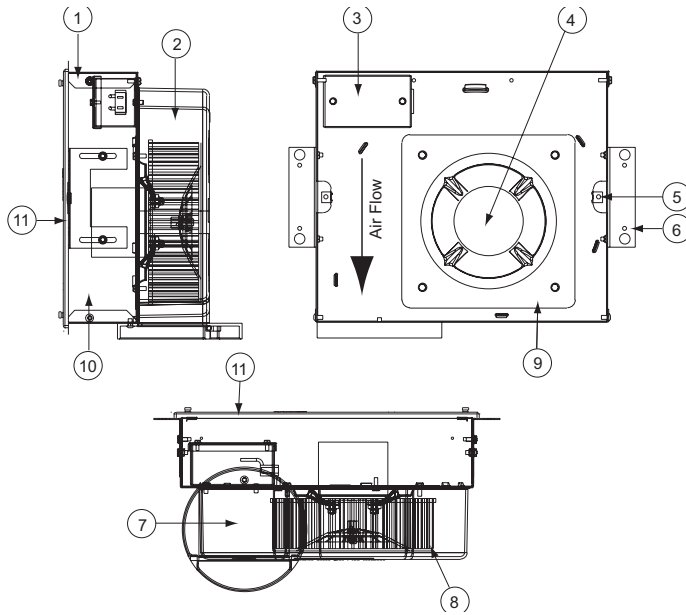

## Gemini 200-900 Parts List

Part No.	Size 200-700	Size 800-900
1	Backdraft Damper	Backdraft Dampers (2)
2	Damper Frame	Damper Frame (2)
3	Mounting Bracket (2)	Mounting Bracket (2)
4	Wheel	Wheel (2)
5	Grille (Ceiling and Wall)	Grille (Ceiling and Wall)
6	Blower Housing	Blower Housing (2)
7	Motor	Motor
8	Insulation	Insulation
9	Cabinet housing	Cabinet housing
10	Housing Side Cover	Housing Side Cover

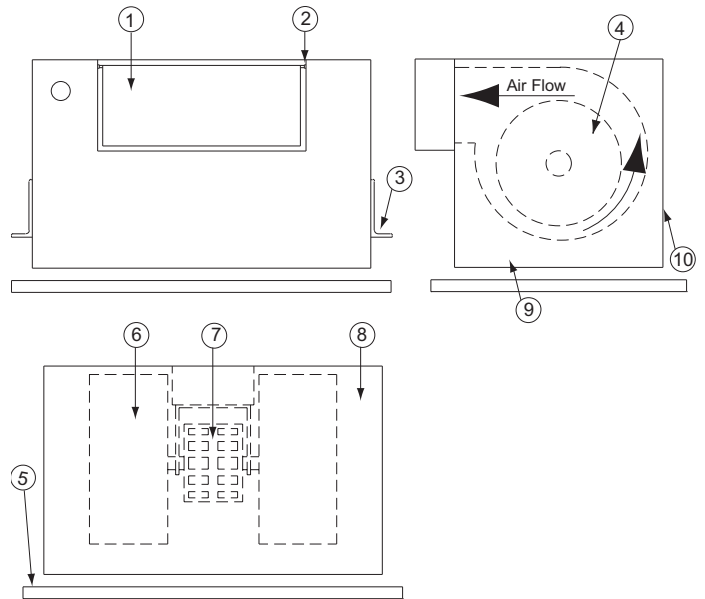

## Gemini 1000–2000 Parts List

Part No.	Part Description
1	Grille (ceiling and wall)
2	Backdraft Damper (2)
3	Wheel (2)
4	Blower Housing (2)
5	Motor
6	Insulation
7	Mount Brackets (2)
8	Cabinet housing
9	Housing Side Cover

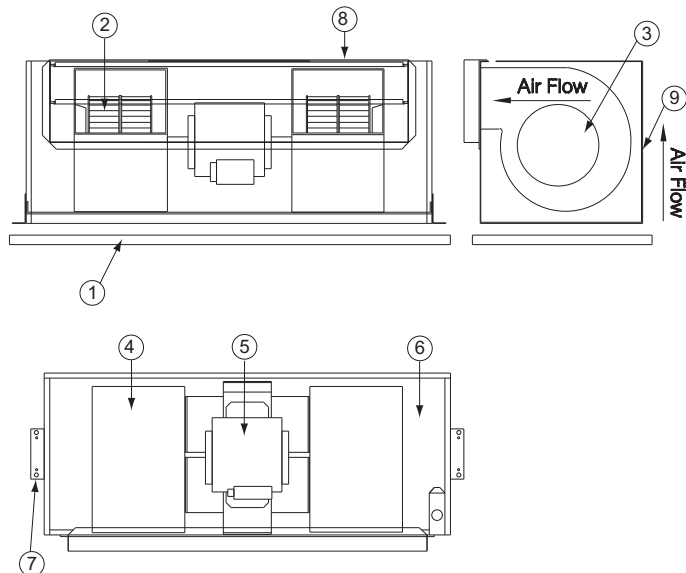

### Limited Warranty

Loren Cook Company warrants that your Loren Cook fan was manufactured free of defects in materials and workmanship, to the extent stated herein. For a period of one (1) year after date of shipment, we will replace any parts found to be defective without charge, except for shipping costs which will be paid by you. This warranty is granted only to the original purchaser placing the fan in service. This warranty is void if the fan or any part thereof has been altered or modified from its original design or has been abused, misused, damaged or is in worn condition or if the fan has been used other than for the uses described in the company manual. This warranty does not cover defects resulting from normal wear and tear. To make a warranty claim, notify Loren Cook Company, General Offices, 2015 East Dale Street, Springfield, Missouri 65803-4637, explaining in writing, in detail, your complaint and referring to the specific model and serial numbers of your fan. Upon receipt by Loren Cook Company of your written complaint, you will be notified, within thirty (30) days of our receipt of your complaint, in writing, as to the manner in which your claim will be handled. If you are entitled to warranty relief, a warranty adjustment will be completed within sixty (60) business days of the receipt of your written complaint by Loren Cook Company. This warranty gives only the original purchaser placing the fan in service specifically the right. You may have other legal rights which vary from state to state.



# LOREN COOK COMPANY

Corporate Offices: 2015 E. Dale St. Springfield, MO 65803  
 Phone 417-869-6474 | Fax 417-862-3820 | [lorencook.com](http://lorencook.com)

# SUBMITTAL REVIEW

Date: July 12, 2024

To:	Fennell-Purifoy Architects 100 Morgan Keegan Dr, Suite #320 Little Rock, AR 72202		
Attention:	Christian Martin		
From:	Michael Biebesheimer, P.E.		
Re:	EF-01 & 02 Exhaust Fans Submittal for Approval		
Project No.	FP-057	Project Name:	Hugg and Hall Mobile Storage Addition

<input type="checkbox"/>	<input checked="" type="checkbox"/>	<input type="checkbox"/>	<input type="checkbox"/>	<input type="checkbox"/>	<input type="checkbox"/>	<input type="checkbox"/>
<b>CODE 1</b> <b>Approved</b>	<b>CODE 2</b> <b>Approved</b> <b>as Noted</b>	<b>CODE 3</b> <b>Approved</b> <b>As Noted /</b> <b>Confirm</b>	<b>CODE 4</b> <b>Revise and</b> <b>Resubmit</b>	<b>CODE 5</b> <b>Not</b> <b>Approved</b>	<b>CODE 6</b> <b>Comments</b> <b>Attached</b>	<b>CODE 7</b> <b>Receipt</b> <b>Acknowledged</b>

1. EF-01, -02: Cook GN-186 Inline Fan – **Approved as noted**
  - a. Provide 75 CFM inline exhaust fan at EF-02 per equipment schedules in lieu of submitted 150 CFM fan.

## SHOP DRAWING REVIEW

Contractor's obligation to perform and complete the Work in accordance with the Contract Documents shall be absolute. Engineer's review and approval will be only to determine if the items covered by the submittals will conform to the information given in the Contract Documents and be compatible with the design concept. Engineer's review and approval will not extend to means, methods, techniques, sequences, or procedures of construction or to safety precautions or programs incident thereto.



# SUBMITTAL

## Hugg and Hall Mobile Storage

**Powers of Arkansas  
5440 Northshore Drive  
North Little Rock, AR 72118**



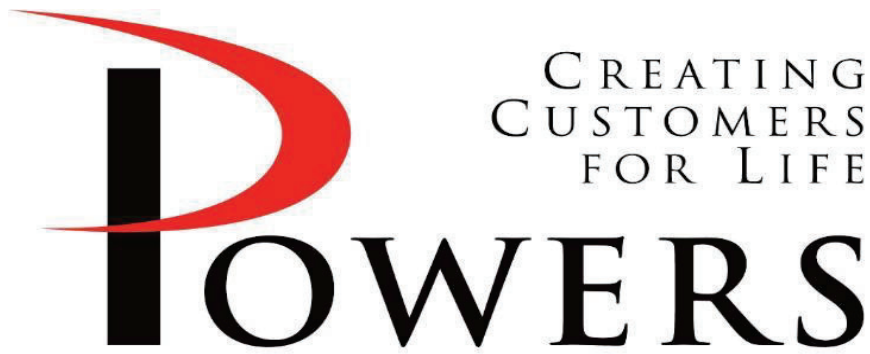

# SUBMITTAL

<b>PRODUCT</b>	Exhaust Fans
<b>MANUFACTURER</b>	Loren Cook
<b>JOB NAME</b>	Hugg and Hall Mobile Storage
<b>LOCATION</b>	Little Rock, AR
<b>ENGINEER</b>	Brown Engineers
<b>CONTRACTOR</b>	Comfort Systems
<b>DATE</b>	6/18/2024
<b>SUBMITTED BY</b>	Todd Given

5440 Northshore Drive - North Little Rock, Arkansas 72118 - Tel: 501.374.5420 Fax: 501.370.9298





# COOK



MARK: EF-01,02

PROJECT: HUGG & HALL MOBILE STORAGE

DATE: 6/18/2024

## GEMINI

### Inline Fans 100 Series

#### STANDARD CONSTRUCTION FEATURES:

Forward curved injection molded polypropylene fan wheel - Injection molded flame resistant fan housing with round outlet duct - 22 ga. galvanized steel inlet box - Permanently lubricated 2-speed motor with built-in thermal overload protection and disconnect plug - Isolation mounted motor, mounted to one piece galvanized stamped steel integral motor mount/inlet - Field wiring compartment with receptacle - Adjustable prepunched mounting bracket - Shipped in ISTA certified transit tested packaging.

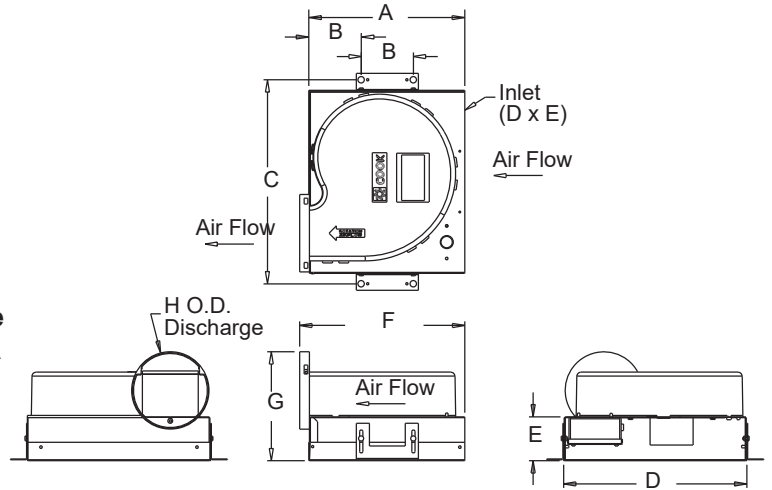

#### Performance

Qty	Catalog Number	Flow (CFM)	SP (inwc)	Nominal RPM	Input Watts	Speed Control
2	GN-186	150	.250	816	65	FSC

Altitude (ft): 266 Temperature (F): 70

#### Motor Information

Volts/Ph/Hz	Nameplate Amps
115/1/60	.817

#### Sound Data Inlet Sound Power by Octave Band

1	2	3	4	5	6	7	8	LwA	dBA	Sones
51	55	58	52	50	46	43	38	55	44	2.5

- Distance from Sound source 5 ft

#### Accessories:

- ROOF CAP-CRB W/BDSCR
- FAN SPEED CONTROLLER 5 AMP 120 VOLT
- GEMINI ISOLATOR KIT - ISOLATORS
- ROOF CURB RCG 16-13.5H

#### Dimensions (inches)

A	12
B	4
C	15-5/8
D	14
E	3-3/8
F	12-3/4
G	8-3/8
H O.D.	5-15/16

NOTE: Accessories may affect dimensions shown.

Weight(lbs)***	Shipping	56	Unit	53
----------------	----------	----	------	----

\*\*\*Includes fan, motor & accessories.

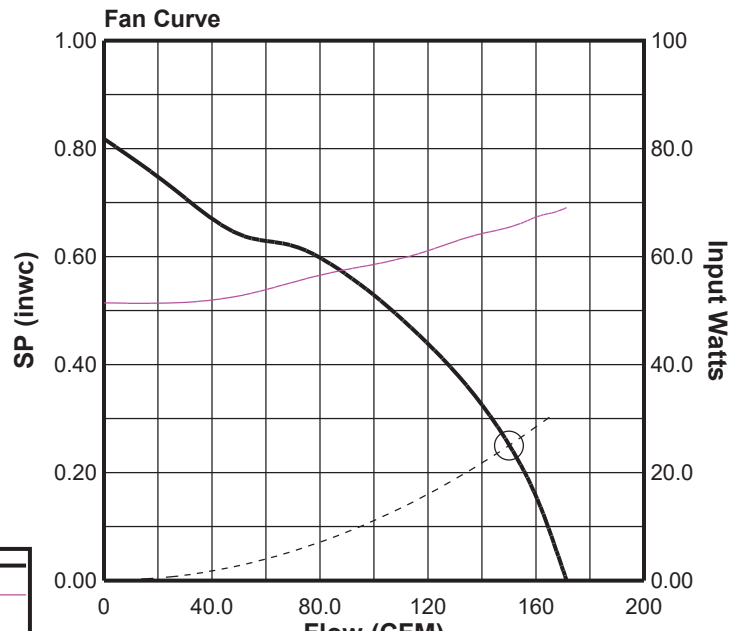

#### Fan Curve Legend

CFM vs SP	—
CFM vs Watts	—
Point of Operation	○



# COOK

PROJECT: HUGG & HALL MOBILE STORAGE

DATE: 6/18/2024

## GEMINI

### ROOF CAP Curb Mount

#### STANDARD CONSTRUCTION FEATURES:

Aluminum construction - Anti-backdraft flange

Optional birdscreen - PR8, PR12, PR16, and PR20 are curb mount.

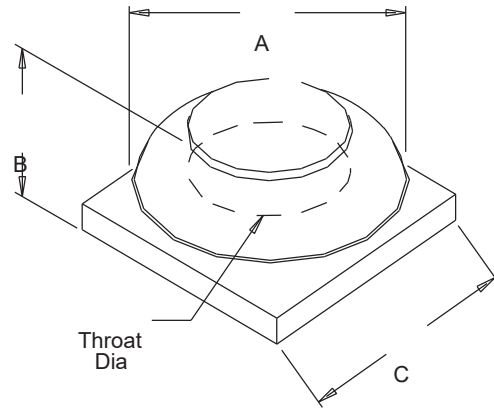

#### Dimensions (inches)

Mark	Qty	Description	A	B	C	Throat Dia.
EF-01,02	2	ROOF CAP-CRB W/BDSCR	18-1/4	10-1/8	18	8-19/32



## FSC

### Fan Speed Controls

#### STANDARD CONSTRUCTION FEATURES:

**PRODUCT DESCRIPTION** - Through the "Quadrac" integrated semi-conductor device it is now possible to offer this system with many advantages. Fewer semi-conductor parts mean greater reliability and the passivation process used in the manufacture of the semi-conductor insures long life.

Printed circuit construction eliminates wiring difficulties and guarantees workmanship.

All of these factors serve to offer the most important of all features - quality.

**SPEED CONTROL** - Positive Off/On action in the control dial. Speed range set to the customer's requirements. **CONTROL RATING** - 120 volts, 60 cycles, 1 phase. Maximum ambient temperature - 120 degree F (5 AMP, 10 AMP, 15 AMP). 220/240 volt, 50/60 cycles, 1 phase. Maximum ambient temperature - 120 degree F (5 AMP, 10 AMP). 220/240 volt model not UL listed. Fan cannot have UL listing if furnished with prewired 220/240 volt FSC. 277 volt, 60 cycles, 1 phase.

Maximum ambient temperature - 120 degree F (5 AMP). **WARNING** - Power must be turned off before installing this unit. **STANDARD INSTALLATION** - Fits any standard single gang box.

Turn off power and connect the two wires on the control to the two switch wires in the usual manner. The connection box is not supplied. **SPECIAL FEATURES** - Complete range control, solid state "Quadrac" integrated circuitry, solid state construction for long reliable operating life, saves on electric bills.

#### Dimensions (inches)

Mark	Qty	Description
EF-01,02	2	FSC 5 AMP 120 VOLT

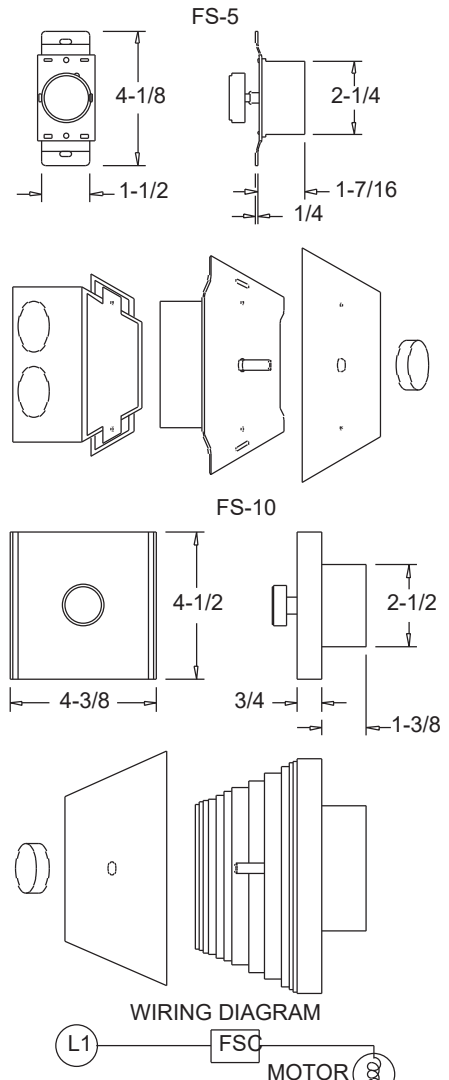



# COOK

PROJECT: HUGG & HALL MOBILE STORAGE

DATE: 6/18/2024

## GEMINI

Gemini Isolator Kit  
GIK  
Rubber In Shear

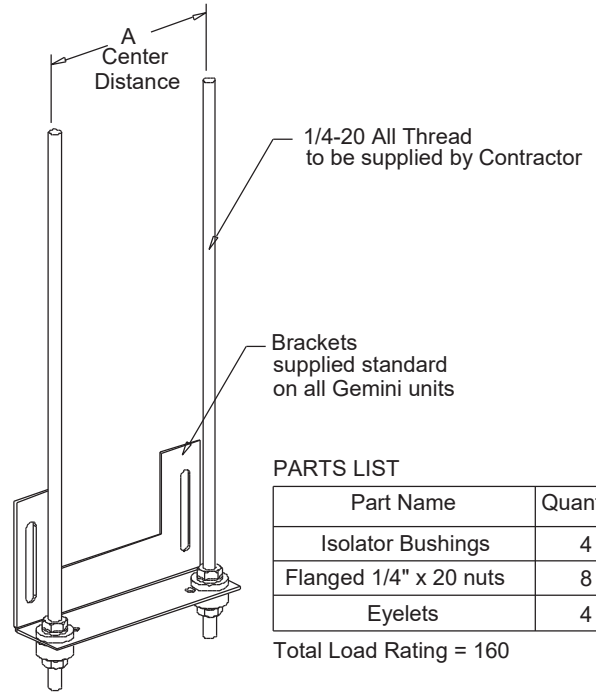

### Dimensions (inches)

Mark	Qty	Description	Part #	A
EF-01,02	2	GEMINI ISOLATO	GIK	4



## RCG

### Galvanized Steel Roof Curb

#### STANDARD CONSTRUCTION FEATURES:

18 gauge galvanized steel - 1-1/2",  
3 lbs. density thermal and acoustical  
insulation - Continuously welded corners -  
Wood nailer.

#### Options:(As noted below\*)

- 1) No wood nailer (deduct 1-1/2" for actual height).
- 2) Damper tray.
- 3) Liner.
- 4) Gasket on wood nailer.
- 5) Lorenized coating.
- 6) Enamel coating.
- 7) Burglar bars.

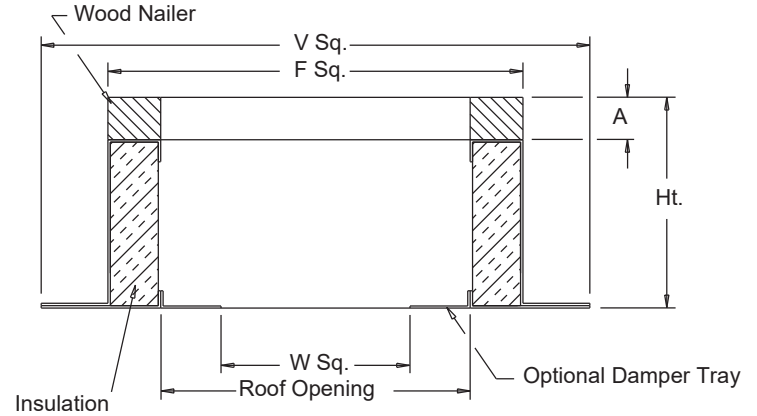

#### Dimensions (inches)

Mark	Qty	Description	Ht	Options*	A	F Sq.	V Sq.	W Sq.	Roof Opening
EF-01,02	2	RCG 16	13.5	-	1-1/2	16-1/2	20-1/2	9-3/4	13-1/2