



BRADFORD WHITE[®]
W A T E R H E A T E R S

**Residential Electric and Light Duty
Commercial Electric Water Heaters**



SERVICE **MANUAL**

Troubleshooting Guide
and Instructions for Service

(To be performed ONLY by
qualified service providers)

Models Covered by This Manual:

Residential:

RE1, RE2 & RE3 Upright Models.
RE1 & RE2 Lowboy Models.
RE1 Utility Models.
RE1 Wall Hung Models.

Light Duty:

LE Upright Models.
LE Utility Models.
LE Lowboy.
LE Wall Hung.



As required by the state of California Proposition 65.

Table of Contents

	<u>Page</u>	<u>Service Procedure</u>
Introduction.....	2	---
Tools.....	2	---
General Information.....	3	---
Sequence of Operation.....	6	---
Single Element Operation.....	6	---
Double Element Non-Simultaneous Single Phase.....	7	---
Double Element Simultaneous Single Phase 4 wire Service.....	8	---
Double Element Non-Simultaneous 3 Phase.....	9	---
Double Element Simultaneous 3 Phase.....	10	---
Double Element Non-Simultaneous Single Phase Off Peak	11	---
Troubleshooting.....	12	- - -
Line Voltage and High Limit ECO Testing.....	14	RE-I
Heating Element Testing.....	15	RE-II
Residential Thermostat Testing	16	RE-III
Single Element	16	
Double Element, 4 wire, Simultaneous, Single Phase	16	
Double Element, Non-Simultaneous, Single Phase	17	
Double Element, Non-Simultaneous, 3 Phase	19	
Double Element, Simultaneous, 3 Phase	21	
Double Element, Non-Simultaneous, Single Phase, Off Peak ...	23	
Light Duty Commercial Thermostat Testing	25	RE IV
Double Element, Non-Simultaneous, Single Phase.....	25	
Double Element, Simultaneous, Single Phase	27	
Double Element, Non-Simultaneous, 3 Phase	29	
Double Element, Simultaneous, 3 Phase	31	
Thermostat Removal and Replacement	33	RE-V
Heating Element Removal and Replacement	34	RE-VI
DipTube and Anode Inspection and Replacement	35	RE-VII
Generic Parts List	36	---

Introduction

This service manual is designed to aid service and maintenance professionals on the function, proper diagnosis and repair of Bradford White residential electric and light duty commercial electric water heaters.

The text and illustrations in this manual provide step by step instructions to facilitate proper operation and troubleshooting procedures. Contact the Bradford White Technical Support Group immediately if diagnosis can not be made using the methods described in this service manual.

Tools

- | | |
|------------------------|------------------------------|
| - Multi Meter | - Phillips Head Screw Driver |
| - 1-½ Deep Well Socket | - Thermometer |
| - ¼" Nut Driver | - Drain Hose |

Various Hand Tools: Pipe Wrench, Channel Locks, Pliers (common & needle nose), Wire cutters, Wire Strippers, Flash Light.

Commonly Used Formulas

Amps = $\frac{\text{Watts}}{\text{Volts}}$ (for single phase units) Example: $4500\text{W}/240\text{V} = 18.75\text{A}$

Amps = $\frac{\text{Watts}}{\text{Volts} \times 1.732}$ (for balanced 3 phase units) Example: $4500\text{W}/240\text{V} \times 1.732 = 10.82\text{A}$

Watts = Amps x Volts Example: $18.75\text{A} \times 240\text{V} = 4500\text{W}$

Ohms = $\frac{\text{Volts}^2}{\text{Watts}}$ Example: $(240\text{V})^2 / 4500\text{W} = 12.8 \text{ Ohms}$

Common Service Wire Configurations

120 VOLT

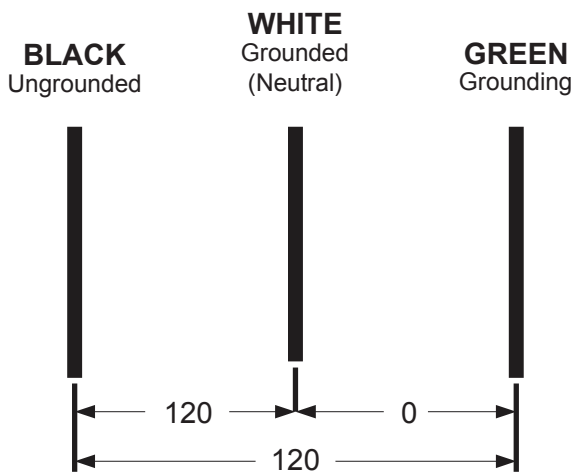

240 VOLT

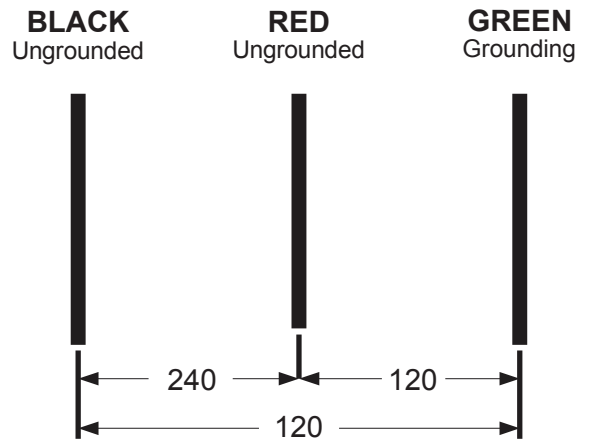

208 3Ph

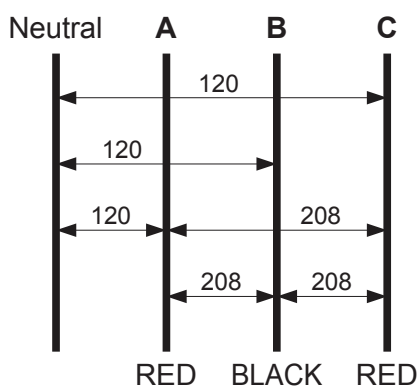

240 3Ph

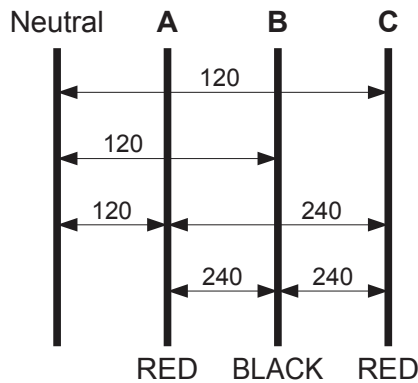

480 3Ph/277 1 Ph

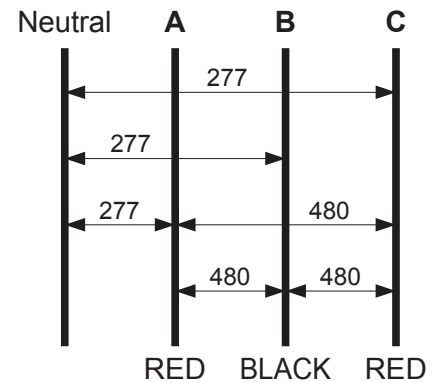

Wattage Limitations at Various Voltages

Residential Electric Upright RE2 & RE3 Series (Non-Simultaneous Operation)
 Residential High Efficiency Upright RE2 Series (Non-Simultaneous Operation)
 Residential Electric Lowboy RE2 Series (Non-Simultaneous Operation)

Maximum Wattage	Element Upper/Lower	Voltage
3,000	3,000/3,000	120
6,000	6,000/6,000	208, 240
6,000	6,000/6,000	277, 480

Residential Electric Upright RE2 & RE3 Series (Simultaneous Operation)
 Residential High Efficiency Upright RE2 Series (Simultaneous Operation)
 Residential Electric Lowboy RE2 Series (Simultaneous Operation)
 Light Duty Commercial Electric LE Series (Non-Simultaneous Operation)
 Light Duty Commercial Electric LE Series (Simultaneous Operation)

Maximum Wattage	Element Upper/Lower	Voltage
3,000	1,500/1,500	120
10,000	5,000/5,000	208
11,000	5,500/5,500	240
12,000	6,000/6,000	277, 480

Residential Electric Utility Series (Single Element Operation)
 Light Duty Utility Series (Single Element Operation)

Maximum Wattage	Single Element	Voltage
3,000	3,000	120
6,000	6,000	208, 240
6,000	6,000	277
6,000	6,000	480

Surface Mounted Thermostats

Surface mounted thermostats are mounted into a bracket which holds the thermostat against the side of the tank. Surface mounted thermostats respond to tank surface temperatures to sense a call for heat, set point temperature settings and high limit (ECO) activation. It is important that the entire back surface of the thermostat is in full contact or flush with the tank. Improperly mounted thermostat will lead to improper water heater operation.

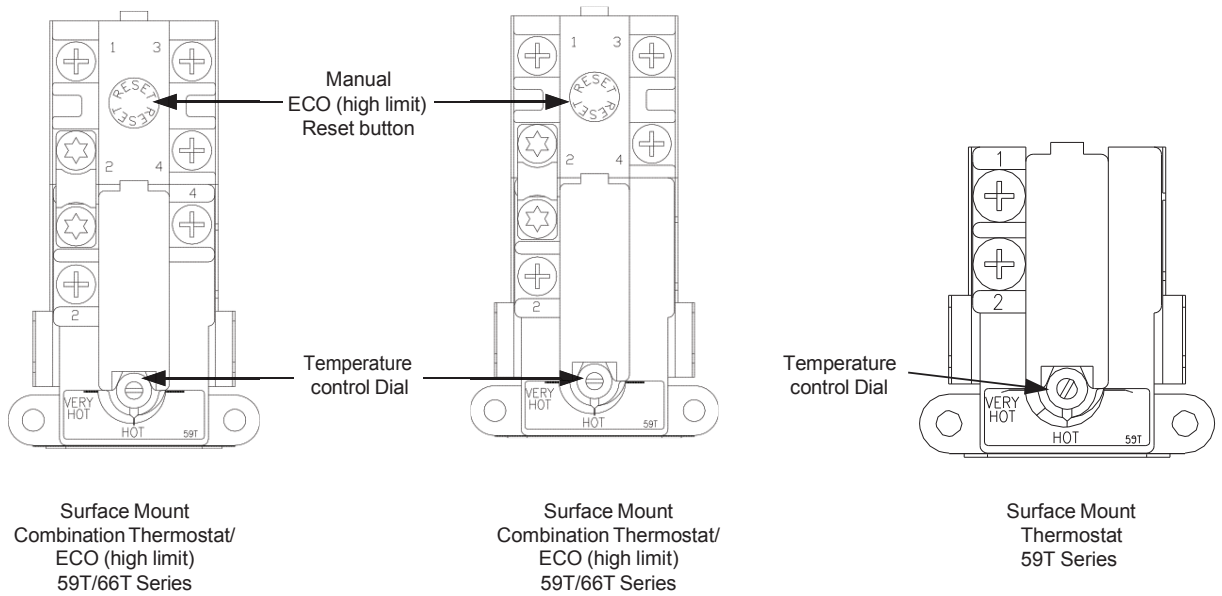

Direct Immersion “Screw-in” Type Heating Element

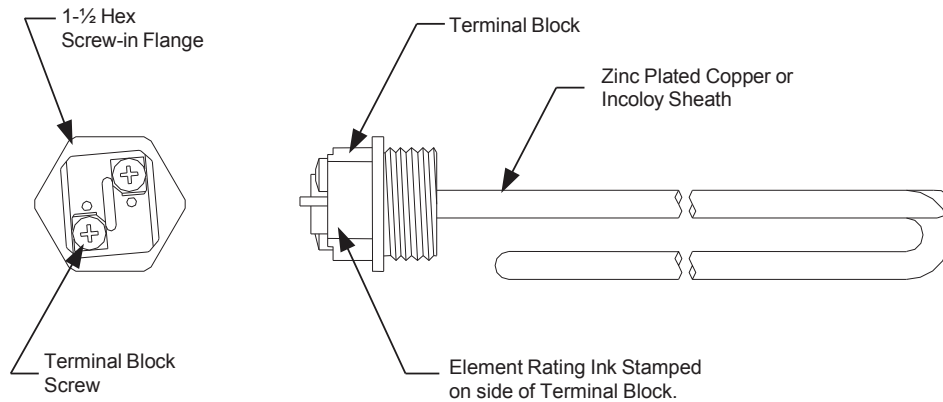

SEQUENCE OF OPERATION

Residential and light duty commercial electric water heaters are designed to operate using several different operating modes. The common modes and sequence of operation are as follows:

1. Single Element Operation.
2. Double Element Non-Simultaneous Operation (single phase).
3. Double Element Non-Simultaneous Operation (3 phase).
4. Double Element Simultaneous Operation (single phase).
5. Double Element Simultaneous Operation (3 phase).

Sequence of Operation- Single Element Operation.

- 1 Line voltage is applied across terminals L1 & L3 of the thermostat. ECO is closed, so there is voltage at terminal L4 and to one side of the element.

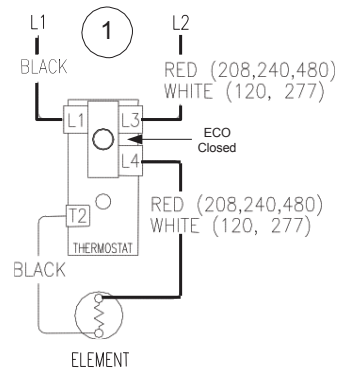

- 2 Tank is cold therefore thermostat is closed at terminal T2 (calling for heat). This completes the circuit and allows current to flow through the element.

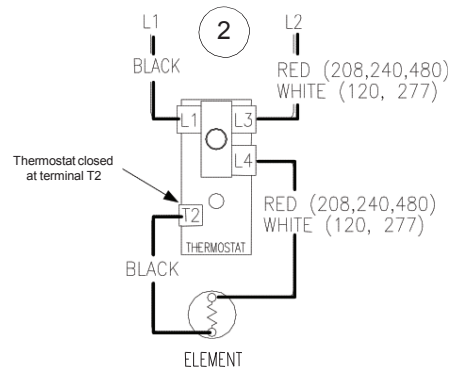

- 3 When the thermostat is satisfied, it opens at terminal T2 interrupting current flow through the element. System is now in stand-by mode, waiting for the next call for heat.

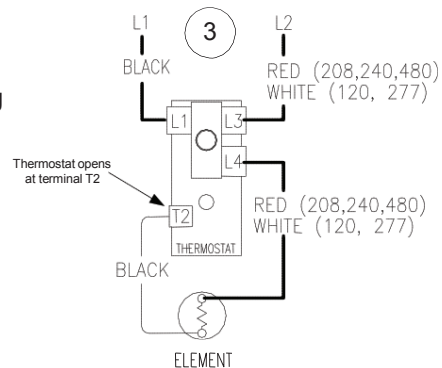

Non-Simultaneous and Simultaneous Operation

Double element electric water heaters are designed to operate in either Non-Simultaneous or Simultaneous mode.

Non-Simultaneous Mode: Allows only one heating element to operate at a time. For example, when the tank is cold, the upper element is energized first, heating the top of the tank. Only when the upper thermostat is satisfied, the upper element is de-energized and power is directed to the lower thermostat, energizing the lower element and heating the bottom portion of the tank until the lower thermostat is satisfied. As hot water is drawn off the tank, it is replaced with cold water delivered through the dip tube to the bottom of the tank. When the tank cools at the lower thermostat level, the lower thermostat will call for heat, energizing the lower element. If enough hot water is drawn from the tank, the top portion of the tank cools and the upper thermostat will call for heat, de-energizing the lower element and allowing only the top element to energize until the upper thermostat is satisfied.

Simultaneous mode: allows both heating elements to operate at the same time. That is, if either thermostat (upper or lower) is calling for heat, the corresponding heating element is energized independent of the other.

Sequence of Operation- Double Element, Non-Simultaneous Operation, Single Phase.

- 1 Line voltage is applied across terminals L1 & L3 of the upper thermostat. ECO is closed, so there is voltage at terminal L4 and to one side of the upper and lower elements.
- 2 Tank is cold. Therefore, the thermostats are closed at terminals T2 & 2 (calling for heat). The circuit is complete through the upper thermostat only, allowing current to flow through upper element.
- 3 When the upper thermostat is satisfied, it opens at terminal T2, interrupting current flow through the upper element. Terminal T4 closes, allowing voltage to pass to terminal 1 of the lower thermostat. This completes the circuit through the lower thermostat and allows current flow through the lower element.
- 4 When the lower thermostat is satisfied, it opens at terminal 2, interrupting current flow through lower element. The system is now in stand-by mode waiting for the next call for heat.

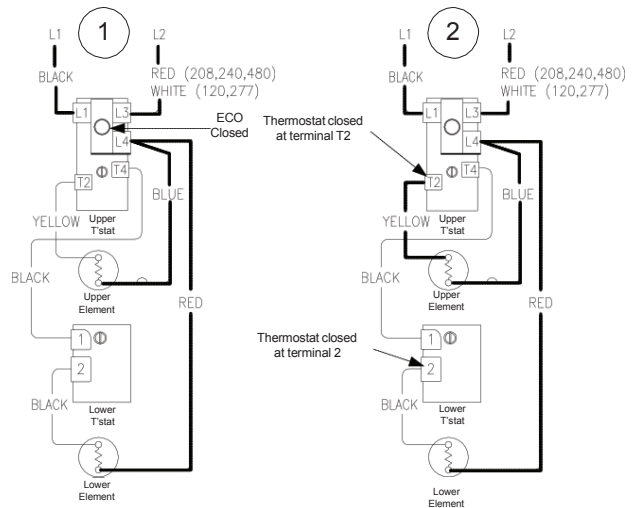

- 5 The lower thermostat/element combination will generally cycle on and off more often than the upper. In some cases, such as a cold tank or in high demand periods, the upper thermostat will call for heat (opening at terminal T4 and closing at terminal T2) prior to the lower thermostat being satisfied. This will interrupt current flow through the lower thermostat and element and allow current to flow through the upper element only. When the upper thermostat is satisfied, it resumes operation as described in sequence #3 above.

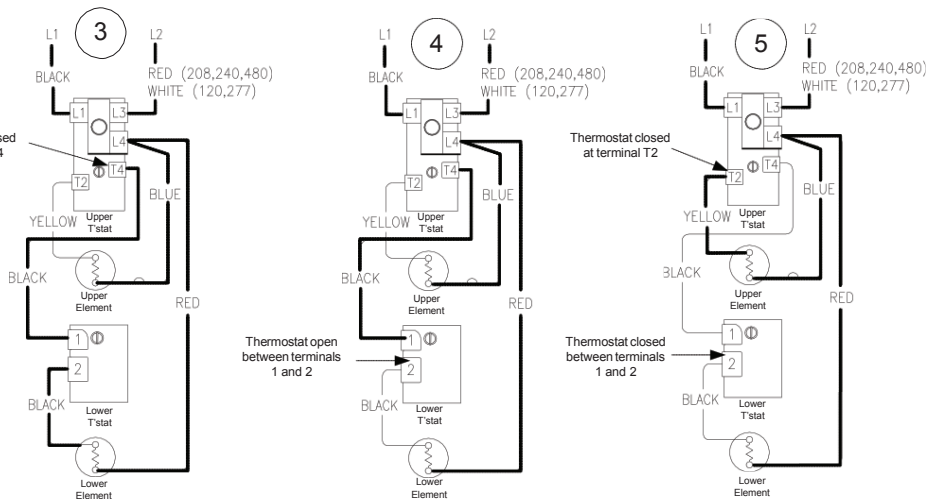

SEQUENCE OF OPERATION

A 4 wire, double element heater wired for simultaneous operation is essentially two single element systems operating independently. The heaters are wired internally with two independent circuits, one circuit for each thermostat/element combination. When installed using a two wire service, the blue and red (or white) wires will be connected together, likewise black and yellow wires will be connected together.

Sequence of Operation- Double Element, Simultaneous Operation, Single Phase, 4 wire service installation.

1 Line voltage from circuit one is applied across terminals L1 & L3 of the lower thermostat. Likewise, line voltage from circuit two is applied across terminals L1 & L3 of the upper thermostat. ECO in both upper and lower thermostat is closed, so there is voltage at terminal L4 of each thermostat and to one side of the upper and lower elements.

2 Tank is cold therefore both thermostats are closed at terminal T2 (calling for heat). This completes the circuit through the thermostats and allows current to flow through the elements.

3 When either thermostat is satisfied, it will open at terminal T2, interrupting current flow through the corresponding element. As both thermostats satisfy, the system will be in stand-by mode waiting for the next call for heat. Thermostats will operate independent of each other.

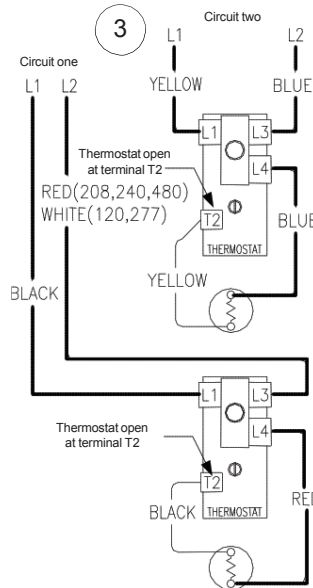
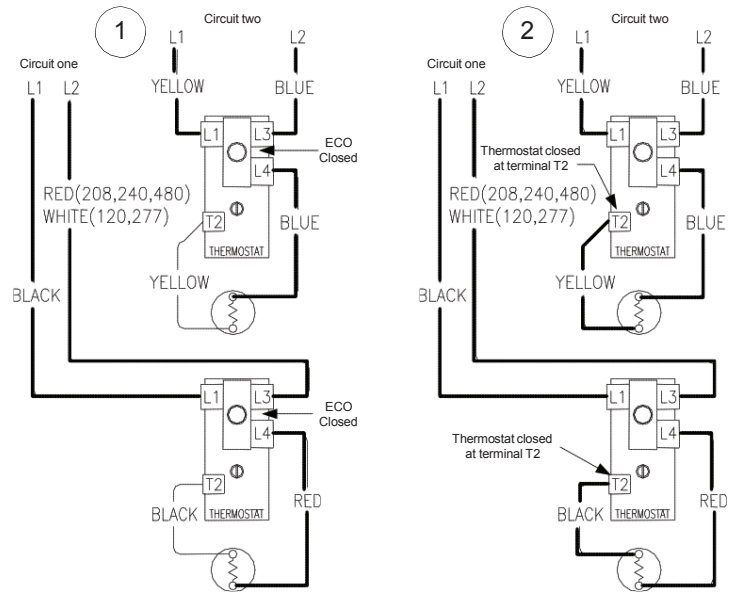

Sequence of Operation- Double Element, Non-Simultaneous Operation, 3 Phase.

- 1 Line voltage is applied across terminals L1 & L3 of upper thermostat. Likewise, Line voltage is applied to terminal L3 of lower thermostat. ECO in both upper & lower thermostat is closed, so there is voltage at terminal L4 of both thermostats and to one side of both upper & lower elements.
- 2 Tank is cold therefore both thermostats are closed at terminal T2 (calling for heat). The circuit is complete through the upper thermostat only allowing current to flow through the upper element.
- 3 When the upper thermostat is satisfied, it opens at terminal T2 interrupting current flow through upper element, and closes at terminal T4 allowing voltage to pass to terminal L1 of lower thermostat. This completes the circuit through the lower thermostat allowing current flow through lower element.
- 4 When the lower thermostat is satisfied, it opens at terminal T2 interrupting the current flow through the lower element. The system is now in stand-by mode waiting for the next call for heat.
- 5 The lower thermostat/element combination will generally cycle on and off more often than the upper. In some cases, such as a cold tank or in high demand periods, the upper thermostat will call for heat (opening at terminal T4 and closing at terminal T2) prior to the lower thermostat being satisfied. This will interrupt current flow through the lower thermostat and element and allow current to flow through the upper element only. When the upper thermostat is satisfied, it resumes operation as described in sequence #3 above.

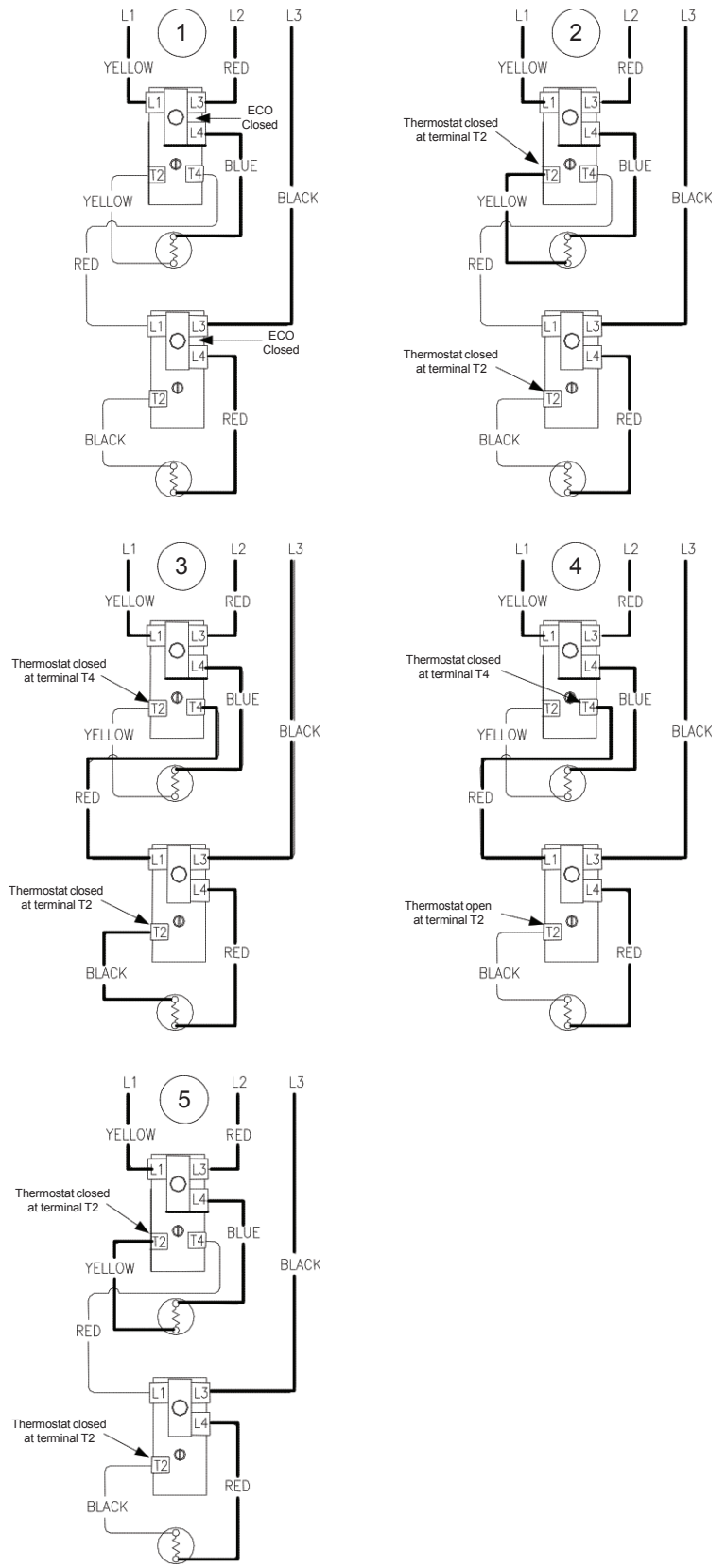

Sequence of Operation- Double Element, Simultaneous Operation, 3 Phase.

- 1 Line voltage is applied across terminals L1 & L3 of upper thermostat. Line voltage also extends to terminal L1 of lower thermostat. Also, line voltage is applied to terminal L3 of lower thermostat. ECO in both upper & lower thermostat is closed, so there is voltage at terminal L4 of both thermostats and to one side of both upper & lower elements.
- 2 Tank is cold therefore both thermostats are closed at terminal T2 (calling for heat). This completes the circuit through the thermostats and allows current to flow through the elements.

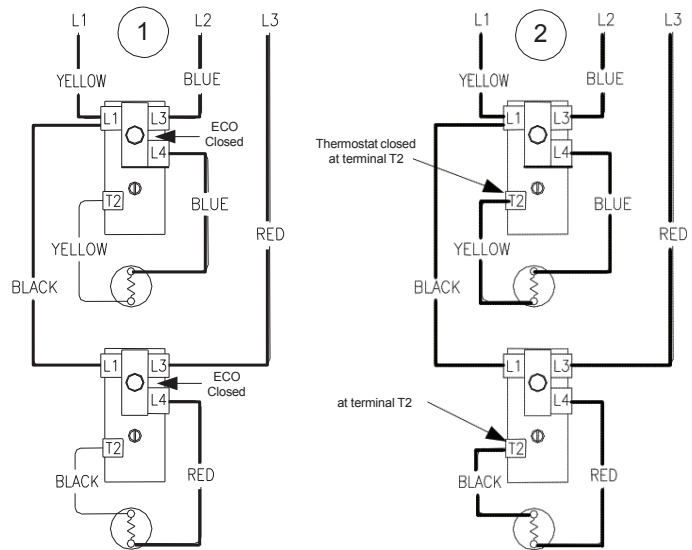

- 3 When either thermostat is satisfied, it will open at terminal T2, interrupting current flow through the corresponding element. As both thermostats satisfy, the system will be in stand-by mode waiting for the next call for heat. Thermostats will operate independent of the other.

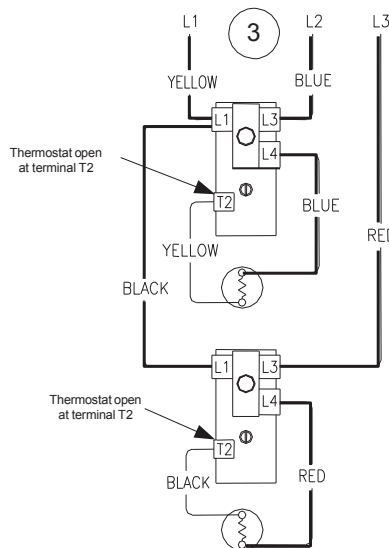

Some electric utility companies will offer discounts for using electricity during “Off Peak” Times of the day. The system allows the use of an “Off Peak” meter, which interrupts power to the lower element during high power demand periods.

Sequence of Operation- Double Element, Non-Simultaneous Operation, Single Phase, Off Peak.

- 1 Line voltage is applied across terminals L1 & L3 of the upper thermostat. Line voltage from off peak meter is supplied to terminal L1 of lower thermostat. ECO in the upper thermostat is closed, so there is voltage at terminal L4 of upper thermostat and to one side of the upper element.
- 2 Tank is cold therefore both thermostats are closed at terminal T2 (calling for heat). The circuit is complete through the upper thermostat only, allowing current to flow through upper element.
- 3 When upper thermostat is satisfied, it opens at terminal T2 interrupting current flow through upper element, and closes at terminal T4 allowing voltage to pass to one side of the lower element. This completes the circuit through the lower thermostat and off peak meter allowing current flow through lower element.
- 4 When the lower thermostat is satisfied, it opens at terminal T2 interrupting current flow through lower element. The system is now in stand-by mode waiting for the next call for heat

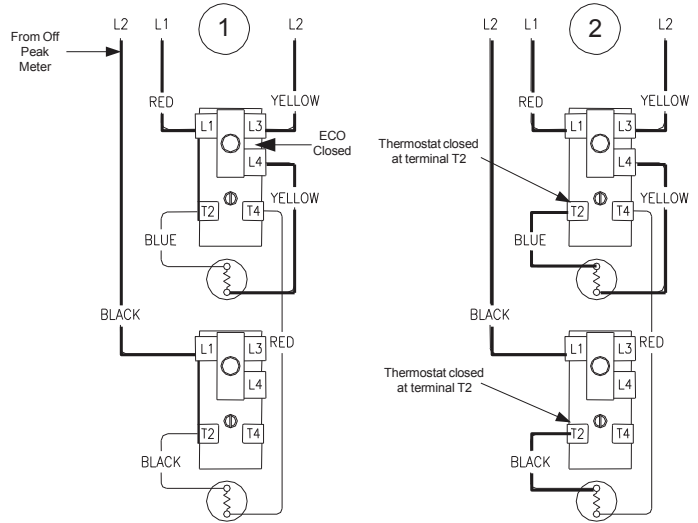

- 5 During peak power demand periods as determined by the local utility, the off peak meter will interrupt power to terminal L1 of lower thermostat. Only the top thermostat/element combination is allowed to operate during this period.

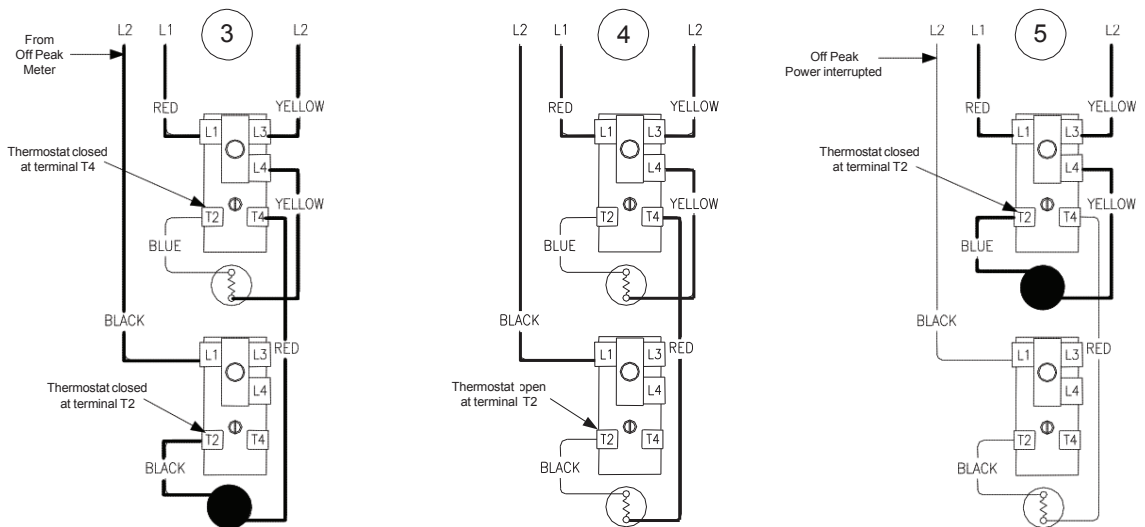

Most common cause for improper electric water heater operation can be linked to heating element failure.

When troubleshooting an electric water heater with the incidence of “No Hot Water” or “Insufficient Amount of Hot Water,” It’s always a good idea to check the heating elements first by following the procedure on page 15.

Common Heating Element Failures:

1. **Dry Firing.** Element may be partially submerged in water or most likely, completely exposed with no water in tank. In some cases, sediment or lime build up around an element can eventually cause an air pocket, and within seconds, result in a dry fired element. At this point the element becomes inoperative. When element replacement is required, be sure the tank is full of water prior to energizing the water heater.
2. **Grounded Element.** An element with a short circuit to ground will in most cases cause the circuit breaker in the service panel to open or shut off. In some cases, there may not be enough current draw for the circuit breaker to open. This will allow the heating element to be in continuous operation resulting in over heated water, limited only by the ECO or Energy Cut Out. Repeated actuation of the ECO is usually the result of a grounded element.
3. **Sediment build up.** Slow hot water recovery can usually be traced back to sediment or lime build up around heating element. Sediment build up can also over time cause a dry fired element.

Figure 1, below shows a common “Screw-In” type heating element identifying certain features commonly referred to throughout this manual.

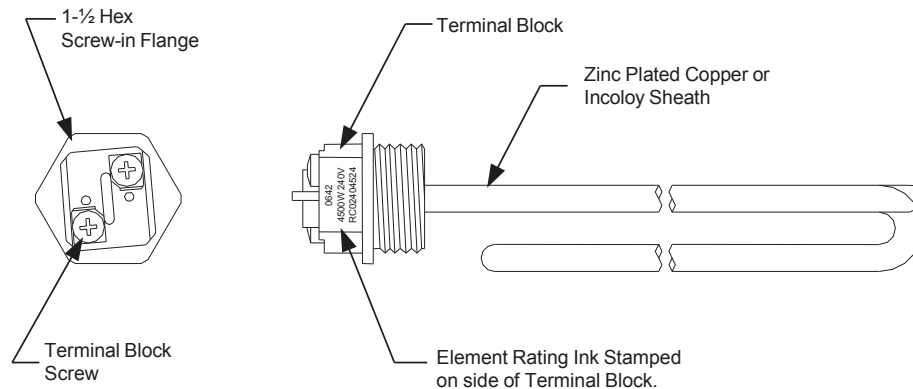

Figure 1
Typical Direct Immersion “Screw-In”
Type Heating Element

Quick Step Plan to Hot Water

1. TURN OFF power to water heater and check all wire connections to ensure they are tight and corrosion free.
2. Turn power "ON" and determine that service voltage is present, and the high limit (ECO) has not actuated (see procedure on page 14).
3. Check for inoperative heating element (see procedure on page 15).
4. Check for proper thermostat operation (see procedures beginning on page 16). NOTE: Thermostat testing procedures assume items 2 and 3 above are in working order.

⚠ WARNING
High voltage exposure. Use caution when making voltage checks to avoid personal injury.

<u>SYMPTOM</u>	<u>PROBABLE CAUSE</u>	<u>CORRECTIVE ACTION</u>	<u>SERVICE PROCEDURE</u>
No Hot Water	<ol style="list-style-type: none"> 1. No Power to heater. 2. Loose wire connections. 3. Inoperative upper heating element. 4. Inoperative upper thermostat. 5. Open ECO. 	<ol style="list-style-type: none"> 1. Check fuses or circuit breakers in service panel. 2. Check all wire connections. 3. Check heating element(s). Replace as needed. 4. Check thermostat(s) operation. Replace as needed. 5. Check ECO. Reset or replace thermostat(s) as needed. 	<ol style="list-style-type: none"> 3. See Service Procedure RE-II, Page 15. 4. See Service Procedure RE-III, Page 16. 5. See Service Procedure RE-I, Page 14.
Not Enough Hot Water	<ol style="list-style-type: none"> 1. Inoperative lower heating element. 2. Thermostat(s) set to low. 3. Inoperative thermostat(s). 4. Loose wire connection. 5. Sediment or lime build up on element(s). 6. High demand period. 7. Undersized heater. 8. Very cold inlet water to heater. 9. Plumbing connections reversed. 10. Damaged dip tube. 	<ol style="list-style-type: none"> 1. Check heating element(s), replace as needed. 2. Increase thermostat setting. 3. Check thermostat(s), replace as needed. 4. Check all wire connection. 5. Remove heating element(s) and check for lime build up. 6. Reduce demand. 7. Replace with larger heater. 8. Temper water to heater. 9. Correct plumbing connections. 10. Check dip tube, replace as needed. 	<ol style="list-style-type: none"> 1. See Service Procedure RE-II, Page 15. 3. See Service Procedure RE-III, Page 16. 5. See Service Procedure RE-VI, Page 34. 10. See Service Procedure RE-VII, Page 35.
Slow Hot Water Recovery	<ol style="list-style-type: none"> 1. Sediment or lime build up on element(s). 2. Loose wire connections. 3. Inoperative thermostat(s). 4. Derated heating element installed. 	<ol style="list-style-type: none"> 1. Remove heating element(s) and check for lime build up. 2. Check all wire connections. 3. Check thermostat(s), replace as needed. 4. Check terminal block of element for proper voltage and wattage rating. 	<ol style="list-style-type: none"> 1. See Service Procedure RE-VI, Page 34. 3. See Service Procedure RE-III, Page 16.
Over Heated Water or Continued Operation	<ol style="list-style-type: none"> 1. Thermostat not in contact with tank. 2. Grounded heating element(s). 3. Thermostat set too high. 4. Inoperative thermostat(s). 5. Inoperative ECO. 6. Undersized water heater. 	<ol style="list-style-type: none"> 1. Position thermostat flush with tank surface. 2. Check heating element(s). Replace as needed. 3. Adjust thermostat(s) to desired setting. 4. Check thermostat(s), replace as needed. 5. Check ECO, replace thermostat as needed. 6. Replace with larger heater. 	<ol style="list-style-type: none"> 1. See Service Procedure RE-V, Page 33. 2. See Service Procedure RE-II, Page 15. 4. See Service Procedure RE-III, Page 16. 5. See Service Procedure RE-I, Page 14.
Noisy (singing or hissing) Elements	<ol style="list-style-type: none"> 1. Lime formation on elements. 	<ol style="list-style-type: none"> 1. Remove and clean heating elements. Replace as needed. 	<ol style="list-style-type: none"> 1. See Service Procedure RE-VI, Page 34.

SERVICE PROCEDURE RE-I Line Voltage & High Limit (ECO) Testing

Line Voltage Testing

1. Turn "OFF" power to water heater.
2. Remove access cover(s) from front of water heater. Remove insulation and plastic cover from thermostat.
3. Set multi-meter to "Volts AC."
4. Turn power "ON" to water heater.
5. Check voltage across terminals L1 & L3 of upper thermostat (see Figure 2).
 - A) Rated voltage IS present, power to the water heater is okay.
 - B) Rated voltage NOT present, Check circuit breaker at service panel.

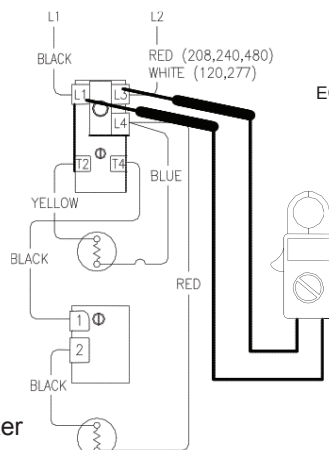
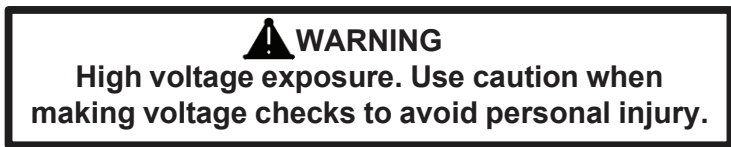

Figure 2

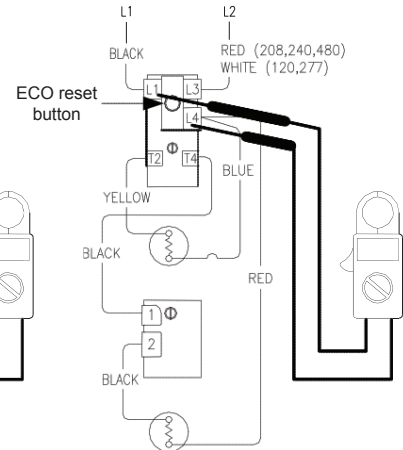

Figure 3

High Limit (ECO) Testing

1. Check voltage across terminals L1 & L4 upper thermostat (see Figure 3).
 - A) Rated Voltage IS present, ECO is okay.
 - B) Rated voltage NOT present, proceed to step 2.
2. Turn power "OFF" to water heater and firmly press ECO reset button on thermostat(s). Turn power "ON" and recheck voltage across terminals L1 & L4 of upper thermostat (see Figure 3).
 - A) Rated voltage IS present, the ECO has previously opened indicating the water in the tank, at some point did overheat, check the following:
 1. Thermostat must be in full contact with tank.
 2. Be sure heating element(s) is not shorted to ground (see page 15).
 3. Proper thermostat operation (see procedures beginning on page 16).
 - B) Rated voltage NOT present, water in tank may be over heated.
 1. If water is hot, turn "OFF" power to water heater and flow water through tank to cool below set point of upper thermostat. Recheck voltage per step 1.
 2. If water is cool, Replace upper thermostat.

Testing For Open Or Burned Out Element

Step 1. **TURN OFF POWER TO WATER HEATER**

Step 2. Remove access cover(s) from front of water heater. Remove insulation and plastic cover from thermostat.

Step 3. Disconnect wires from heating element(s).

Step 4. Set multi-meter to “ohms” setting.

Step 5. Touch probes of multi-meter to screw terminals of heating element(s) (see Figure 4).

Step 6. Reading should be 12.8 ohms (±6%) for a 240 volt, 4500 watt element:

$$\text{Ohms} = \frac{\text{Volts}^2}{\text{Watts}}$$

A reading outside the range using the formula beyond (±6%), indicates a bad element and the element must be replaced.

⚠ WARNING
High voltage exposure. Be sure power is turned OFF to water heater prior to performing this procedure.

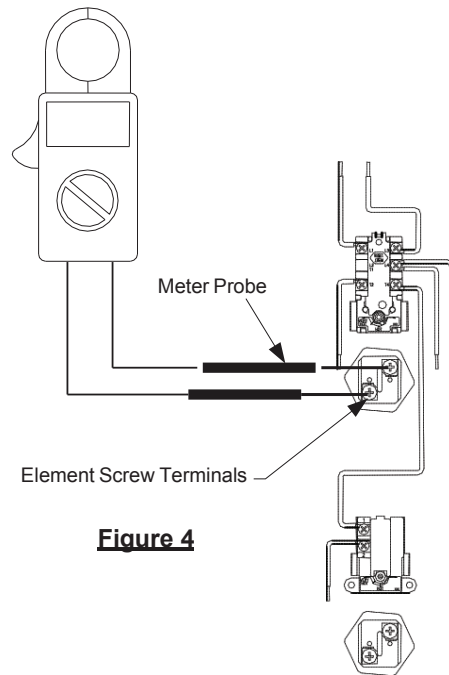

Figure 4

Testing For Heating Element Short Circuit To Ground

Step 1. **TURN OFF POWER TO WATER HEATER**

Step 2. Remove access cover(s) from front of water heater. Remove insulation and plastic cover from thermostat.

Step 3. Disconnect wires from heating element(s).

Step 4. Set multi-meter to “ohms” setting.

terminal of heating element and the other on the element flange (see figure 5). There should be no reading on the ohm meter. Any reading indicates a grounded element and the element must be replaced. Repeat this step for the other screw terminal.

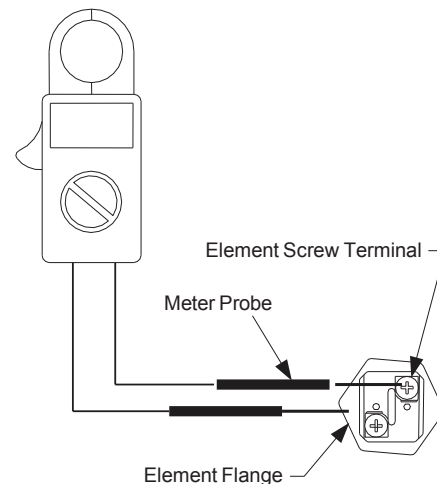

Figure 5

SERVICE PROCEDURE RE-III
Residential Thermostat Testing

**Single Element Operation or Double Element,
4 Wire, Simultaneous, Single Phase Operation**

⚠ WARNING
**High voltage exposure. Use caution to avoid
personal injury during this procedure.**

Water In Tank Is Cold With Power ON

1. This procedure assumes line voltage, ECO and elements are in working order.
2. Turn power "ON" to water heater.
3. Set multi-meter to "Volts AC."
4. Check across terminals L4 and T2 of thermostat (see Figure 6).
 - A) Rated voltage NOT present, Recheck ECO. If ECO is okay, replace thermostat.
 - B) Rated voltage IS present, proceed to next step.
5. Check across element terminals (see Figure 7).
 - A) Rated voltage NOT present, check wire connections from thermostat to element.
 - B) Rated voltage IS present, Repeat element testing see page 15.

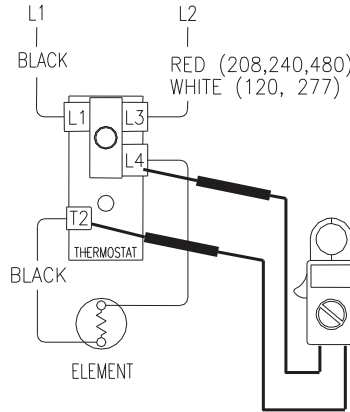

Figure 6

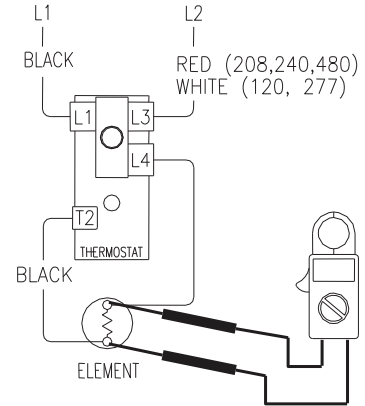
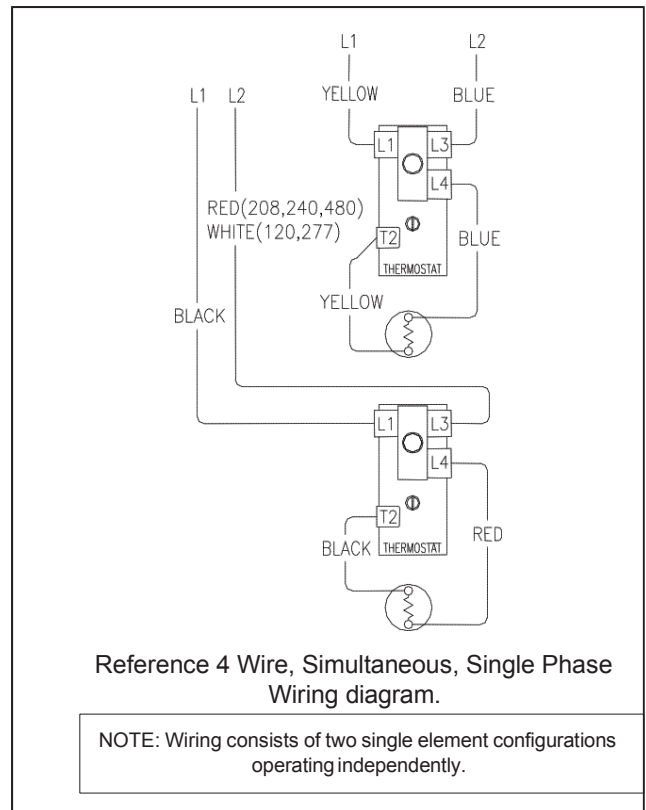

Figure 7

Water Temperature In Tank Is Above Thermostat Setting

1. This procedure assumes line voltage, ECO and elements are in working order.
2. Turn power "ON" to water heater.
3. Set multi-meter to "Volts AC."
4. See Figure 6 above, check across terminals L4 and T2 of thermostat.
 - A) Rated voltage IS present, replace thermostat.
 - B) Rated voltage NOT present, thermostat is okay.
 - C) Lower than rated voltage IS present, recheck for grounded element (see page 15).



Double Element, Non-Simultaneous, Single Phase Operation.

⚠ WARNING
High voltage exposure. Use caution to avoid personal injury during this procedure.

Water In Tank Is Cold With Power ON.

1. This procedure assumes line voltage, ECO and elements are in working order.
2. Turn power "ON" to water heater.
3. Set multi-meter to "Volts AC."
4. Check across terminals L4 and T2 of upper thermostat (see Figure 8).
 - A) Rated voltage NOT present, Recheck ECO. If ECO is okay, replace thermostat.
 - B) Rated voltage IS present, proceed to next step.
5. Check across element terminals (see Figure 9).
 - A) Rated voltage NOT present, check wire connections from thermostat to element.
 - B) Rated voltage IS present, Repeat element testing see page 15.

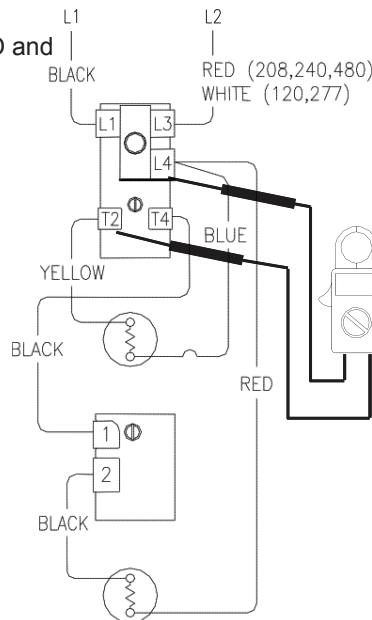

Figure 8

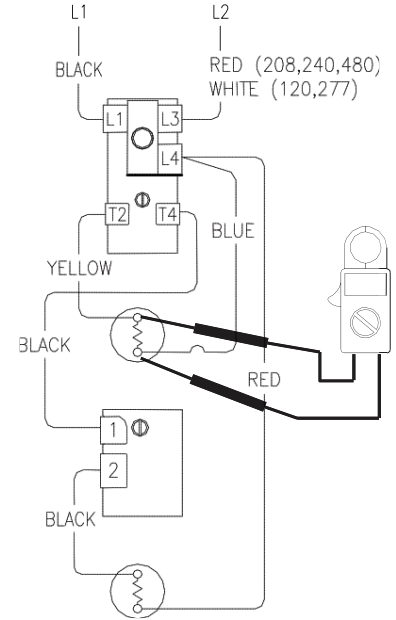

Figure 9

Tank Does Not Deliver Enough Hot Water.

1. This procedure assumes line voltage, ECO and elements are in working order.
2. Turn power "ON" to water heater and set multi-meter to "Volts AC."
3. Adjust temperature setting of upper thermostat to the highest setting. Water temperature in tank must be below thermostat setting for this test.
4. See Figure 8 above, check voltage across terminals L4 and T2 of upper thermostat.
 - A) Rated voltage IS present, okay, upper thermostat is calling for heat. Go to step 5 below.
 - B) Rated voltage NOT present, replace upper thermostat.
5. Adjust temperature setting of upper thermostat to the minimum setting. Water temperature in tank must be above thermostat setting for this test.
6. Check voltage across terminals L4 and T4 of upper thermostat (see Figure 10).
 - A) Rated voltage NOT present, replace upper thermostat.
 - B) Rated voltage IS present, thermostat is okay. Go to step 7 on next page.

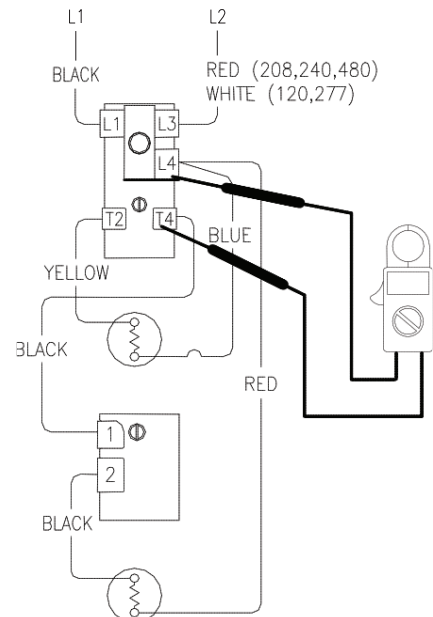

Figure 10

Double Element, Non-Simultaneous, Single Phase Operation (continued).

Not Enough Hot Water (continued).

7. Check voltage across terminal L4 of upper thermostat and terminal 1 of lower thermostat (see Figure 11).
 - A) Rated voltage NOT present, - check wire connection between thermostats.
 - B) Rated voltage IS present, okay, go to step 8.
8. Adjust lower thermostat to highest setting. Water temperature in tank must be below the lower thermostat setting for this test.
9. Check voltage across terminal L4 of upper thermostat and terminal 2 of lower thermostat (see Figure 12).
 - A) Rated voltage NOT present, replace lower thermostat.
 - B) Rated voltage IS present, thermostat is ok.

⚠ WARNING
High voltage exposure. Use caution to avoid personal injury during this procedure.

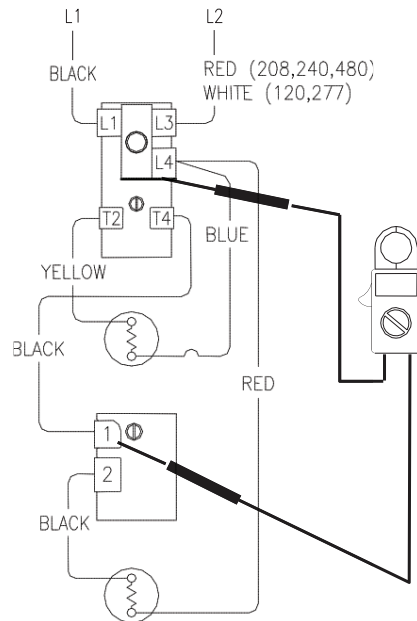

Figure 11

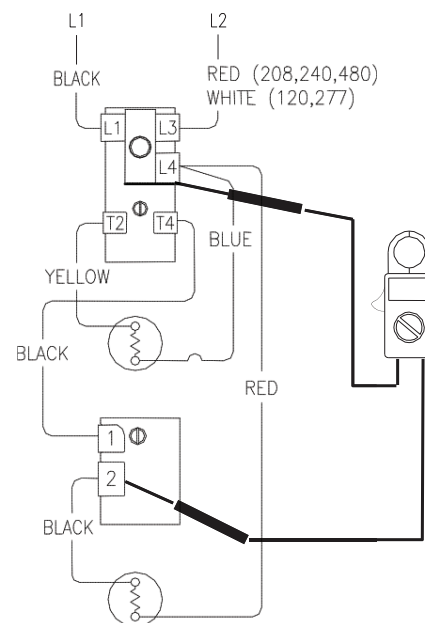

Figure 12

⚠ WARNING
Be sure thermostats are reset to their original temperature settings as found prior to thermostat testing

Water Temperature In Tank Is Above Thermostat Setting.

1. This procedure assumes Line voltage, ECO and elements are in working order.
2. Adjust upper and lower thermostats to the lowest setting.
3. Turn power "ON" to water heater and set multi-meter to "Volts AC."
4. Check across terminals L4 and T2 of upper thermostat (see Figure 8 on page 17).
 - A) Rated voltage IS present, replace upper thermostat.
 - B) Rated voltage NOT present, upper thermostat is okay. Go to step 5 below.
 - C) Lower than rated voltage IS present, recheck for grounded upper element (see page 15).
5. Check across terminals L4 and 2 of lower thermostat (see Figure 12).
 - A) Rated voltage IS present, replace lower thermostat.
 - B) Rated voltage NOT present, lower thermostat is okay.
 - C) Lower than rated voltage IS present, recheck for grounded lower element (see page 15).

Double Element, Non-Simultaneous, Three Phase Operation.

Water In Tank Is Cold With Power ON.

⚠ WARNING
High voltage exposure. Use caution to avoid personal injury during this procedure.

1. This procedure assumes line voltage, ECO and elements are in working order.

2. Turn power "ON" to water heater.

3. Set multi-meter to "Volts AC."

4. Check across terminals L4 and T2 of upper thermostat (see Figure 13).

A) Rated voltage NOT present, recheck ECO. If ECO is okay, replace thermostat.

B) Rated voltage IS present, proceed to next step.

5. Check across element terminals (see Figure 14).

A) Rated voltage NOT present, check wire connections from thermostat to element.

B) Rated voltage IS present, repeat element testing, see page 15.

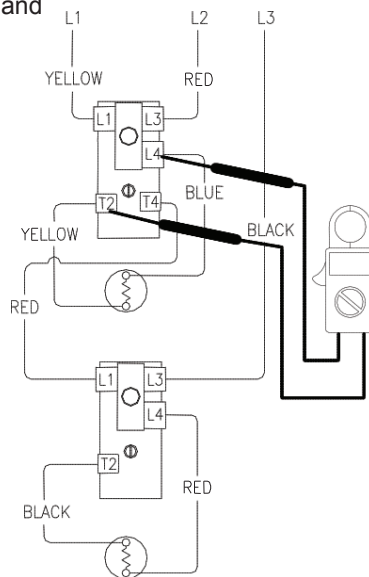

Figure 13

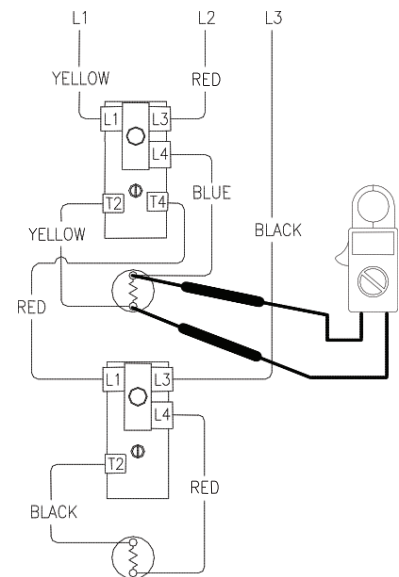

Figure 14

Tank Does Not Deliver Enough Hot Water.

1. This procedure assumes line voltage, ECO and elements are in working order.

2. Turn power "ON" to water heater and set multi-meter to "Volts AC."

3. Adjust temperature setting of upper thermostat to the highest setting. Water temperature in tank must be below thermostat setting for this test.

4. See Figure 13 above, check voltage across terminals L4 & T2 of upper thermostat.

A) Rated voltage IS present, okay, upper thermostat is calling for heat. Go to step 5 below.

B) Rated voltage NOT present, replace upper thermostat.

5. Adjust temperature setting of upper thermostat to the minimum setting. Water temperature in tank must be above thermostat setting for this test.

6. Check voltage across terminals T4 of upper thermostat & L3 of lower thermostat (see Figure 15).

A) Rated voltage NOT present, replace upper thermostat.

B) Rated voltage IS present, upper thermostat is okay. Go to step 7 on next page.

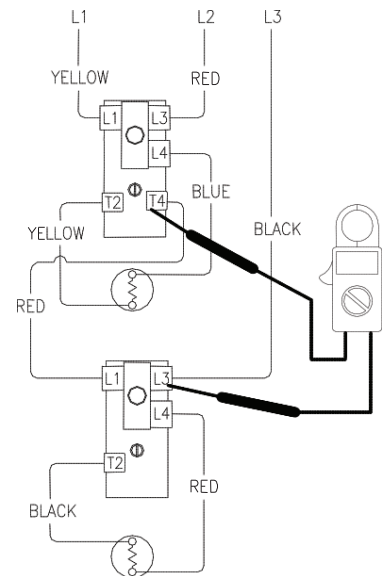

Figure 15

**Double Element, Non-Simultaneous,
Three Phase Operation (continued).**

⚠ WARNING
**High voltage exposure. Use caution to avoid
personal injury during this procedure.**

Tank Does Not Deliver Enough Hot Water (continued)

7. Check voltage across terminal L1 & L3 of lower thermostat (see Figure 16).
 - A) Rated voltage NOT present, check wire connection between thermostats.
 - B) Rated voltage is present, okay, go to step 8.
8. Adjust lower thermostat to highest setting. Water temperature in tank must be below the lower thermostat setting for this test.
9. Check voltage across terminal L4 & T2 of lower thermostat (see Figure 17).
 - A) Rated voltage NOT present, recheck ECO (see page 14). If ECO okay, replace lower thermostat.
 - B) Rated voltage IS present, thermostat is ok. Check wire connection to lower element. If connection okay, recheck lower element (see page 15).

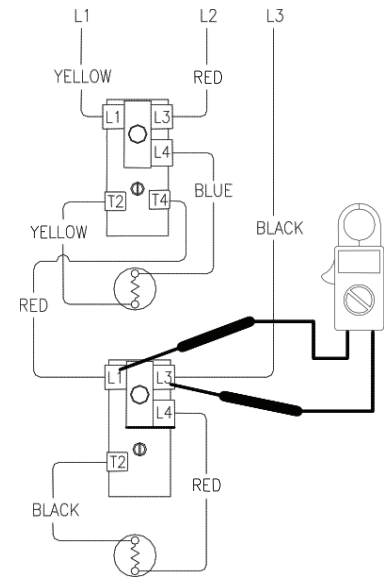

Figure 16

⚠ WARNING
**Be sure thermostats are reset to their original
temperature settings as found prior to
thermostat testing**

Water Temperature In Tank Is Above Thermostat Setting.

1. This procedure assumes line voltage, ECO and elements are in working order.
2. Adjust upper and lower thermostats to the lowest setting.
3. Turn power "ON" to water heater and set multi-meter to "Volts AC."
4. Check across terminals L4 and T2 of upper thermostat (see Figure 13 on page 19).
 - A) Rated voltage IS present, replace upper thermostat.
 - B) Rated voltage NOT present, upper thermostat is okay. Go to step 5 below.
 - C) Lower than rated voltage IS present, recheck for grounded upper element (see page 15).
5. Check across terminals L4 and T2 of lower thermostat (see Figure 17).
 - A) Rated voltage IS present, replace lower thermostat.
 - B) Rated voltage NOT present, lower thermostat is okay.
 - C) Lower than rated voltage IS present, recheck for grounded lower element (see page 15).

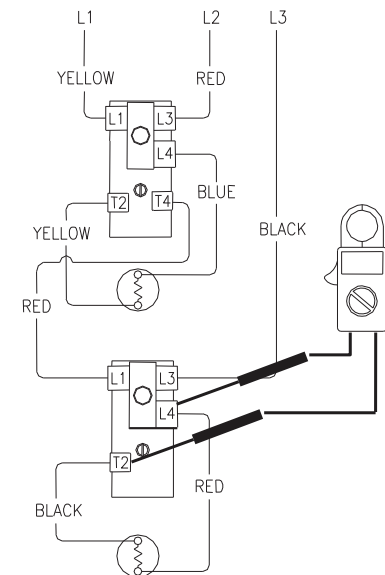

Figure 17

Double Element, Simultaneous, Three Phase Operation.

⚠ WARNING
High voltage exposure. Use caution to avoid personal injury during this procedure.

Water In Tank Is Cold Or Not Enough Hot Water With Power ON.

1. This procedure assumes line voltage, ECO and elements are in working order.
2. Adjust temperature setting for both thermostats to the highest setting.
2. Turn power "ON" to water heater.
3. Set multi-meter to "Volts AC."
4. Check across terminals L4 and T2 of upper thermostat (see Figure 18).
 - A) Rated voltage NOT present, recheck ECO (see page 14). If ECO is okay, replace thermostat.
 - B) Rated voltage IS present, proceed to next step.
5. Check across upper element terminals (see Figure 19).

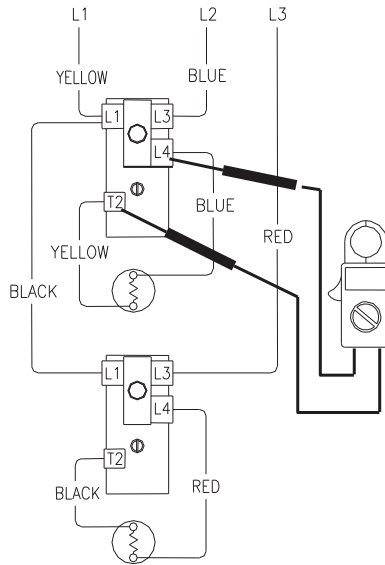

Figure 18

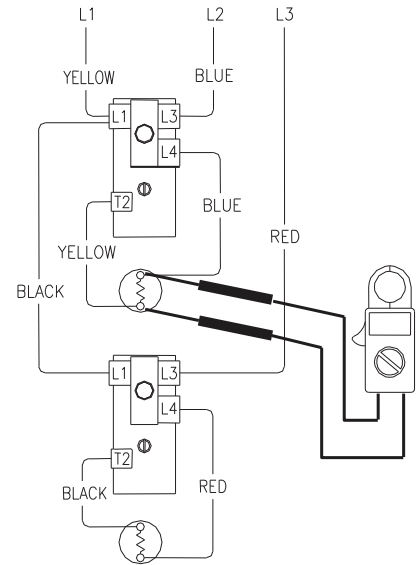

Figure 19

- A) Rated voltage NOT present, check wire connections from thermostat to element.
 - B) Rated voltage IS present, repeat element testing see page 15.
6. Check across terminals L1 & L3 of lower thermostat (see Figure 20).
 - A) Rated voltage NOT present, check wire connections from upper to lower thermostats.
 - B) Rated voltage IS present, okay, go to step 7.
7. Check across terminals L4 and T2 of lower thermostat (see Figure 21).
 - A) Rated voltage NOT present, recheck ECO (see page 14). If ECO is okay, replace thermostat.
 - B) Rated voltage IS present, proceed to next step.
8. Check across lower element terminals.

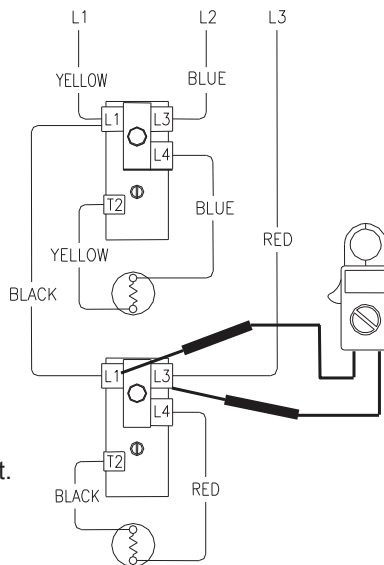

Figure 20

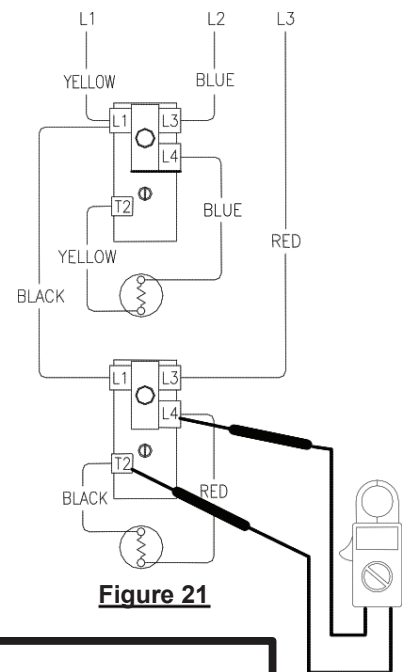

Figure 21

⚠ WARNING
Be sure thermostats are reset to their original temperature settings as found prior to thermostat testing

Double Element, Simultaneous, Three Phase Operation (continued).

Water Temperature In Tank Is Above Thermostat Setting.

1. This procedure assumes line voltage, ECO and elements are in working order.
2. Adjust upper and lower thermostat to the lowest setting.
3. Turn power "ON" to water heater.
4. Set multi-meter to "Volts AC."
5. Check across terminals L4 and T2 of upper thermostat (see Figure 22).
 - A) Rated voltage IS present, replace upper thermostat.
 - B) Rated voltage NOT present, upper thermostat is okay. Go to step 6 below.
 - C) Lower than rated voltage IS present, recheck for grounded upper element (see page 15).
6. Check across terminals L4 and T2 of lower thermostat (see Figure 23).
 - A) Rated voltage IS present, replace lower thermostat.
 - B) Rated voltage NOT present, lower thermostat is okay.
 - C) Lower than rated voltage IS present, recheck for grounded lower element (see page 15).

⚠ WARNING
High voltage exposure. Use caution to avoid personal injury during this procedure.

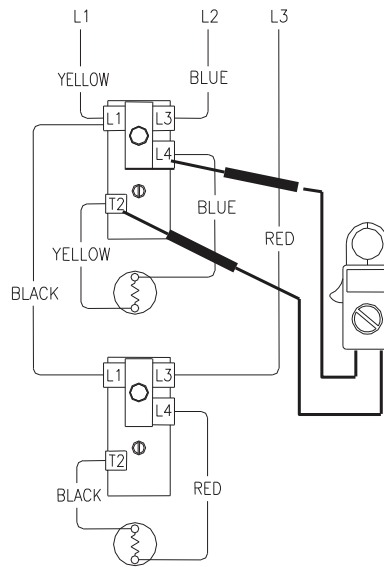

Figure 22

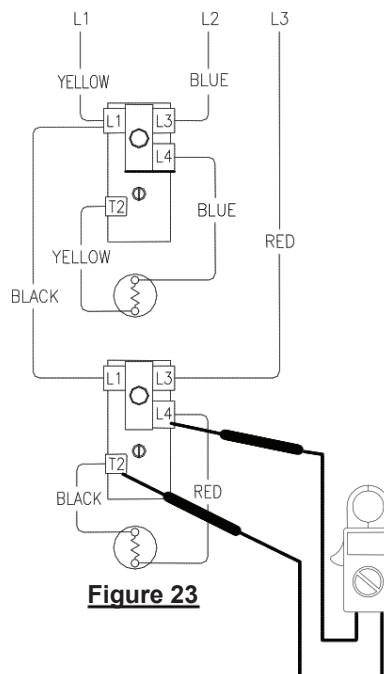

Figure 23

Double Element, Non-Simultaneous, Single Phase, Off Peak Operation.

Water In Tank Is Cold With Power ON.

1. This procedure assumes line voltage, ECO and elements are in working order.
2. Turn power "ON" to water heater.
3. Set multi-meter to "Volts AC."
4. Check across terminals L4 and T2 of upper thermostat (see Figure 24).
 - A) Rated voltage NOT present, recheck ECO (see page 14). If ECO is okay, replace thermostat.
 - B) Rated voltage IS present, proceed to next step.
5. Check across element terminals (see Figure 25).
 - A) Rated voltage NOT present, check wire connections from thermostat to element.
 - B) Rated voltage IS present, Repeat element testing see page 15.

⚠ WARNING
High voltage exposure. Use caution to avoid personal injury during this procedure.

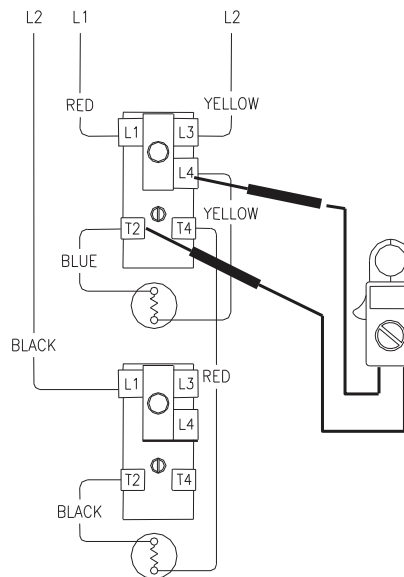

Figure 24

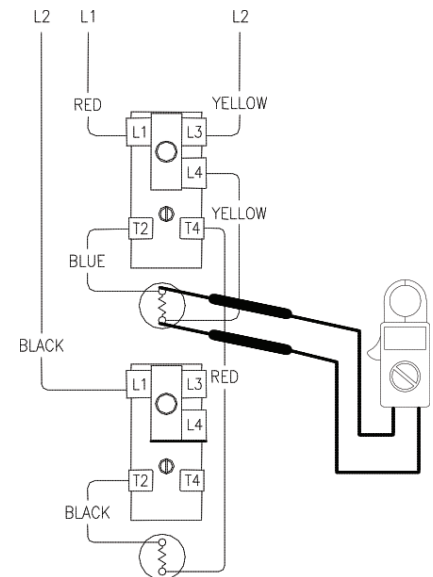

Figure 25

Tank Does Not Deliver Enough Hot Water.

1. This procedure assumes line voltage, ECO and elements are in working order. Be sure OFF PEAK meter has not interrupted line voltage.
2. Turn power "ON" to water heater and set multi-meter to "Volts AC."
3. Adjust temperature setting of upper & lower thermostat to the highest setting. Water temperature in tank must be below thermostat setting for this test.
4. See Figure 24 above. Check voltage across terminals L4 & T2 of upper thermostat.
 - A) Rated voltage IS present, okay, upper thermostat is calling for heat. Go to step 5 below.
 - B) Rated voltage NOT present, replace upper thermostat.
5. Adjust temperature setting of upper thermostat to the minimum setting. Water temperature in tank must be above thermostat setting for this test.
6. Check voltage across terminals T4 of upper thermostat & L1 of lower thermostat (see Figure 26).
 - A) Rated voltage NOT present, replace upper thermostat.
 - B) Rated voltage IS present, upper thermostat is okay. Go to step 7 on next page.

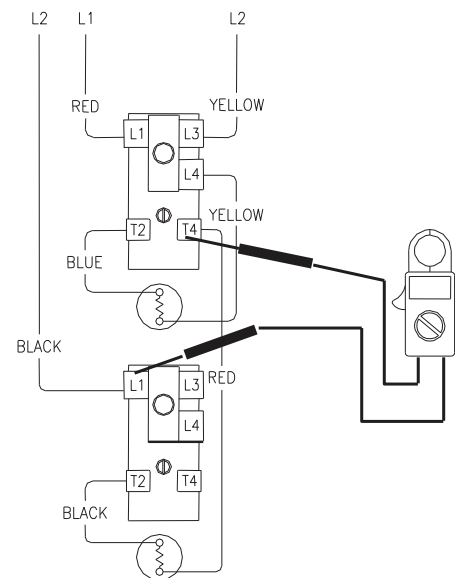

Figure 26

**Double Element, Non-Simultaneous,
Single Phase, Off Peak Operation.**
(continued)

⚠ WARNING
**High voltage exposure. Use caution to avoid
personal injury during this procedure.**

Not Enough Hot Water (continued).

7. Check voltage across terminal T4 of upper thermostat & T2 of lower thermostat. (see Figure 27).
 - A) Rated voltage NOT present, replace lower thermostat.
 - B) Rated voltage is present, okay, go to step 8.
8. Check voltage across lower element (see Figure 28).
 - A) Rated voltage NOT present, check wire connections between thermostats & element.
 - B) Rated voltage IS present, repeat element testing see page 15.

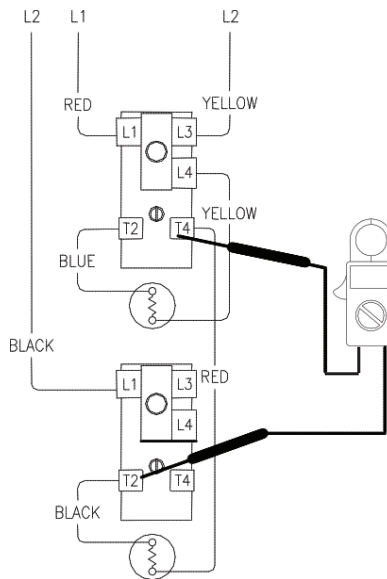

Figure 27

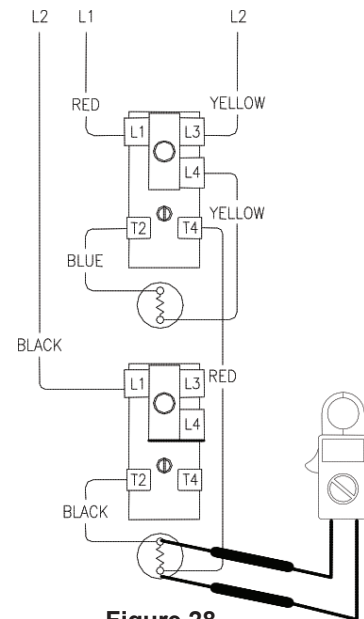

Figure 28

⚠ WARNING
**Be sure thermostats are reset to their original
temperature settings as found prior to
thermostat testing**

Water Temperature In Tank Is Above Thermostat Setting.

1. This procedure assumes line voltage, ECO and elements are in working order.
2. Adjust upper and lower thermostats to the lowest setting.
3. Turn power "ON" to water heater and set multi-meter to "Volts AC."
4. Check across terminals L4 and T2 of upper thermostat (see Figure 24 on page 23).
 - A) Rated voltage IS present, replace upper thermostat.
 - B) Rated voltage NOT present, upper thermostat is okay. Go to step 5 below.
 - C) Lower than rated voltage IS present, recheck for grounded upper element (see page 15).
5. Check across terminals T4 of upper thermostat and T2 of lower thermostat (see Figure 27 above).
 - A) Rated voltage IS present, replace lower thermostat.
 - B) Rated voltage NOT present, lower thermostat is okay.
 - C) Lower than rated voltage IS present, recheck for grounded lower element (see page 15).

Double Element, Non-Simultaneous, Single Phase Operation.

⚠ WARNING
High voltage exposure. Use caution to avoid personal injury during this procedure.

Water In Tank Is Cold With Power ON.

1. This procedure assumes line voltage, ECO and elements are in working order.
2. Turn power "ON" to water heater.
3. Set multi-meter to "Volts AC."
4. Check across terminals L4 and T2 of upper thermostat (see Figure 29).
 - A) Rated voltage NOT present, recheck ECO (see page 14). If ECO is okay, replace thermostat.
 - B) Rated voltage IS present, proceed to next step.
5. Check across element terminals (see Figure 30).
 - A) Rated voltage NOT present, check wire connections from thermostat to element.
 - B) Rated voltage IS present, repeat element testing see page 15.

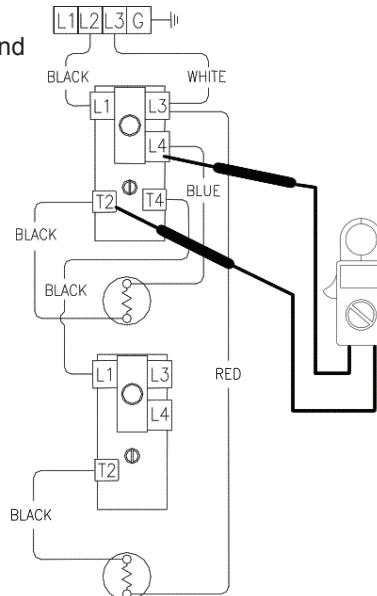

Figure 29

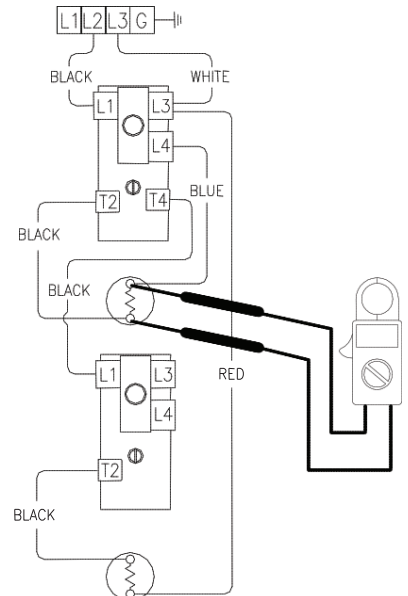

Figure 30

Tank Does Not Deliver Enough Hot Water.

1. This procedure assumes line voltage, ECO and elements are in working order.
2. Turn power "ON" to water heater and set multi-meter to "Volts AC."
3. Adjust temperature setting of upper & lower thermostat to the highest setting. Water temperature in tank must be below thermostat setting for this test.
4. See Figure 29 above. Check voltage across terminals L4 & T2 of upper thermostat.
 - A) Rated voltage IS present, okay, upper thermostat is calling for heat. Go to step 5 below.
 - B) Rated voltage NOT present, replace upper thermostat.
5. Adjust temperature setting of upper thermostat to the minimum setting. Water temperature in tank must be above thermostat setting for this test.
6. Check voltage across terminals L3 & T4 of upper thermostat (see Figure 31).
 - A) Rated voltage NOT present, replace upper thermostat.
 - B) Rated voltage IS present, upper thermostat is okay. Go to step 7 on next page.

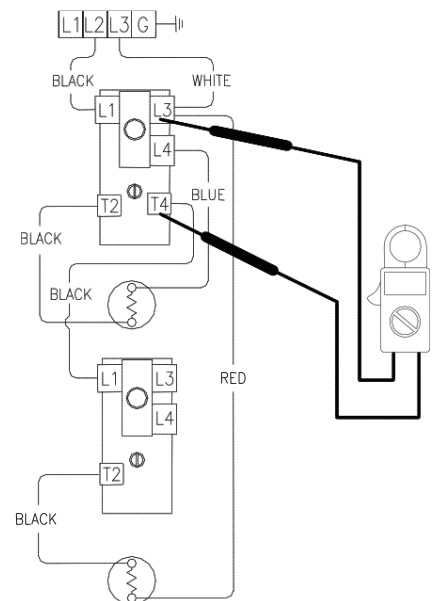

Figure 31

SERVICE PROCEDURE RE-IV
Light Duty Commercial
Thermostat Testing

Double Element, Non-Simultaneous,
Single Phase Operation (continued)

⚠ WARNING
High voltage exposure. Use caution to avoid
personal injury during this procedure.

Tank Does Not Deliver Enough Hot
Water (continued).

7. Check voltage across terminal L3 of upper thermostat & T2 of lower Thermostat. (see Figure 32).
 - A) Rated voltage NOT present, replace lower thermostat.
 - B) Rated voltage is present, okay, go to step 8.
8. Check voltage across lower element (see Figure 33).
 - A) Rated voltage NOT present, Check wire connections between thermostats & element.
 - B) Rated voltage IS present, repeat element testing see page 15.

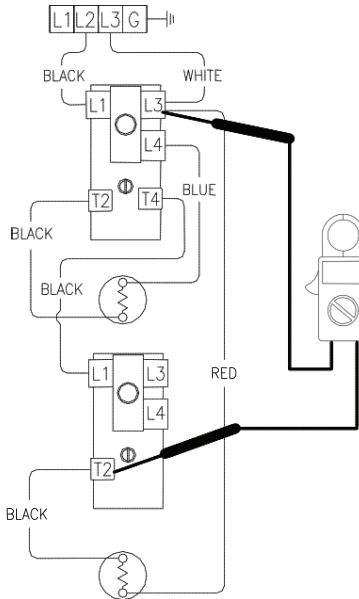

Figure 32

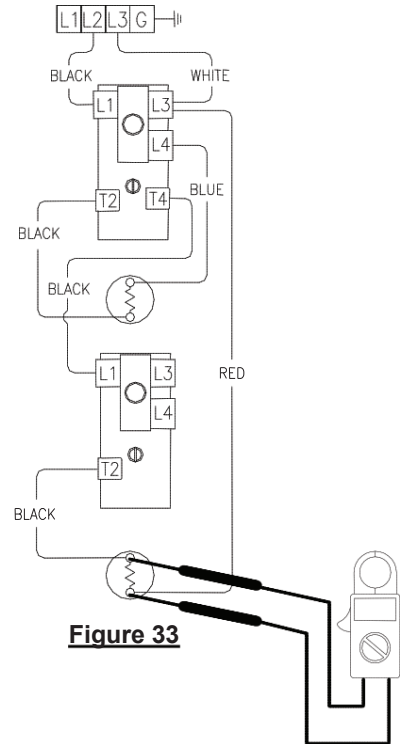

Figure 33

⚠ WARNING
Be sure thermostats are reset to
their original temperature settings
as found prior to thermostat
testing

Water Temperature In Tank Is Above Thermostat Setting.

1. This procedure assumes line voltage, ECO and elements are in working order.
2. Adjust upper and lower thermostat to the lowest setting.
3. Turn power "ON" to water heater and Set multi-meter to "Volts AC."
4. See Figure 32 above. Check across terminal L3 of upper thermostat & T2 of lower thermostat.
 - A) Rated voltage IS present, replace lower thermostat.
 - B) Rated voltage NOT present, okay, go to step 5 below.
 - C) Lower than rated voltage IS present, recheck for grounded lower element see page 15.
5. Check across terminal L4 & T2 of upper thermostat (see Figure 34).
 - A) Rated voltage IS present, replace upper thermostat.
 - B) Rated voltage NOT present, upper thermostat is okay.
 - C) Lower than rated voltage IS present, recheck for grounded upper element see page 15.

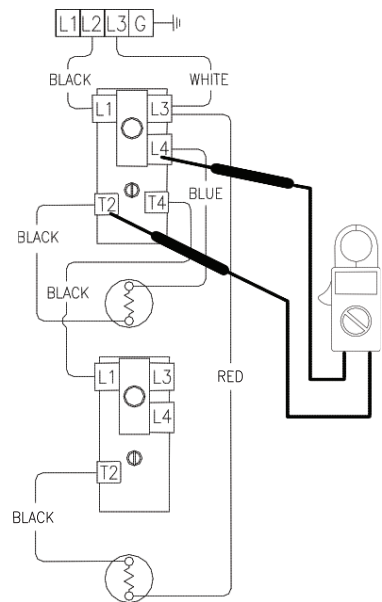

Figure 34

Double Element, Simultaneous, Single Phase Operation.

⚠ WARNING
High voltage exposure. Use caution to avoid personal injury during this procedure.

Water In Tank Is Cold Or Not Enough Hot Water With Power ON.

1. This procedure assumes line voltage, ECO and elements are in working order.
2. Adjust temperature setting for both thermostats to the highest setting.
3. Turn power "ON" to water heater.
4. Set multi-meter to "Volts AC."
5. Check across terminals L4 and T2 of upper thermostat (see Figure 35).
 - A) Rated voltage NOT present, recheck upper ECO (see page 14). If ECO is okay, replace upper thermostat.
 - B) Rated voltage IS present, proceed to next step.
6. Check across upper element terminals (see Figure 36).
 - A) Rated voltage NOT present, check wire connections from thermostat to upper element.
 - B) Rated voltage IS present, repeat element testing see page 15.

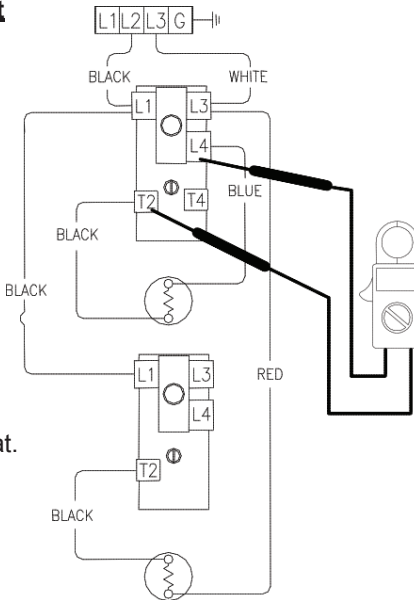

Figure 35

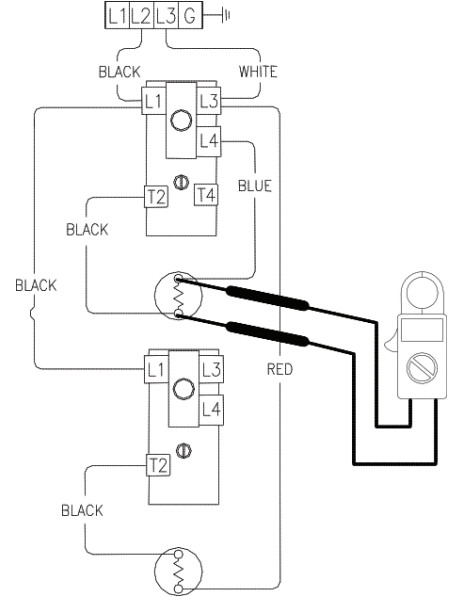

Figure 36

7. Check across terminal L3 of upper thermostat and T2 of lower thermostat (see Figure 37).
 - A) Rated voltage NOT present, check ECO (see page 14) & wire connections at upper & lower thermostats. If okay, replace lower thermostat.
 - B) Rated voltage IS present, proceed to next step.
8. Check across lower element terminals (see Figure 38).
 - A) Rated voltage NOT present, check lower element wire connections to the thermostats.
 - B) Rated voltage IS present, repeat lower element testing see page 15

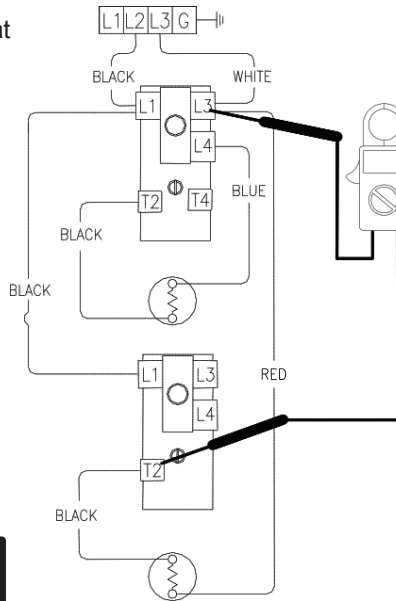

Figure 37

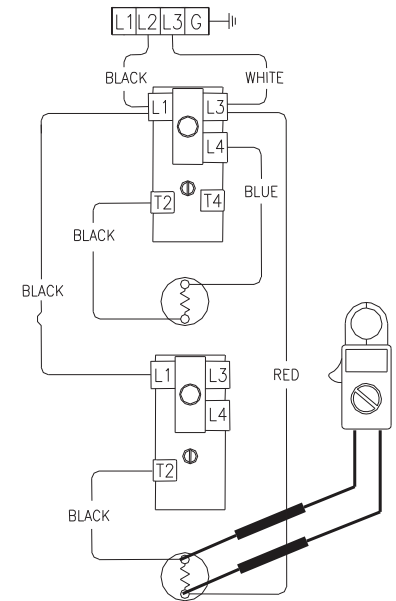

Figure 38

⚠ WARNING
Be sure thermostats are reset to their original temperature settings as found prior to thermostat testing

SERVICE PROCEDURE RE-IV
Light Duty Commercial
Thermostat Testing

Double Element, Simultaneous, Single Phase Operation (continued)

Water Temperature In Tank Is Above Thermostat Setting.

1. This procedure assumes line voltage, ECO and elements are in working order.
2. Adjust upper and lower thermostat to the lowest setting.
3. Turn power "ON" to water heater.
4. Set multi-meter to "Volts AC."
5. Check across terminals L4 and T2 of upper thermostat (see Figure 39).
 - A) Rated voltage IS present, replace upper thermostat.
 - B) Rated voltage NOT present, upper thermostat is okay. Go to step 6 below.
 - C) Lower than rated voltage IS present, recheck for grounded upper element see page 15.
6. Check across terminal L3 of upper thermostat and T2 of lower thermostat (see Figure 40).
 - A) Rated voltage IS present, replace lower thermostat.
 - B) Rated voltage NOT present, lower thermostat is okay.
 - C) Lower than rated voltage IS present, recheck for grounded lower element see page 15.

⚠ WARNING
High voltage exposure. Use caution to avoid personal injury during this procedure.

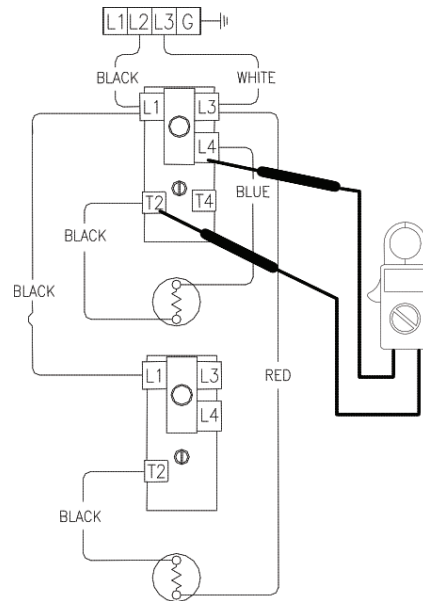

Figure 39

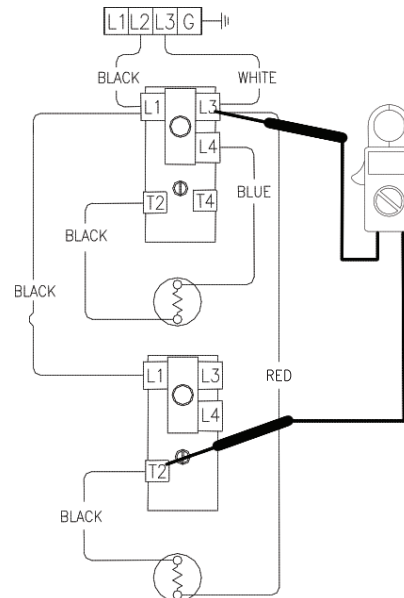

Figure 40

Double Element, Non-Simultaneous, Three Phase Operation.

Water In Tank Is Cold With Power ON.

1. This procedure assumes line voltage, ECO and elements are in working order.
2. Turn power "ON" to water heater.
3. Set multi-meter to "Volts AC."
4. Check across terminals L4 and T2 of upper thermostat (see Figure 41).
 - A) Rated voltage NOT present, recheck upper ECO. If ECO is okay, replace thermostat.
 - B) Rated voltage IS present, proceed to next step.
5. Check across element terminals (see Figure 42).
 - A) Rated voltage NOT present, check wire connections from thermostat to element.
 - B) Rated voltage IS present, repeat element testing see page 15.

⚠ WARNING
High voltage exposure. Use caution to avoid personal injury during this procedure.

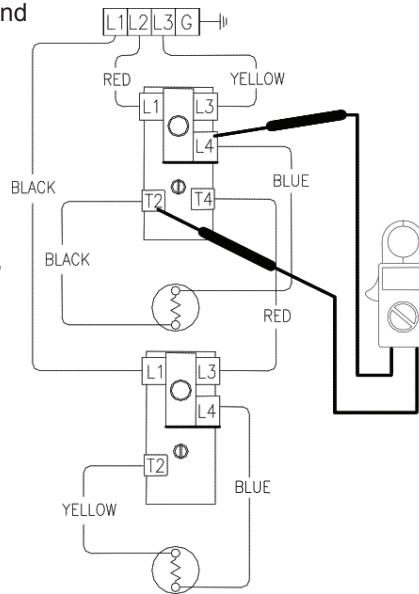

Figure 41

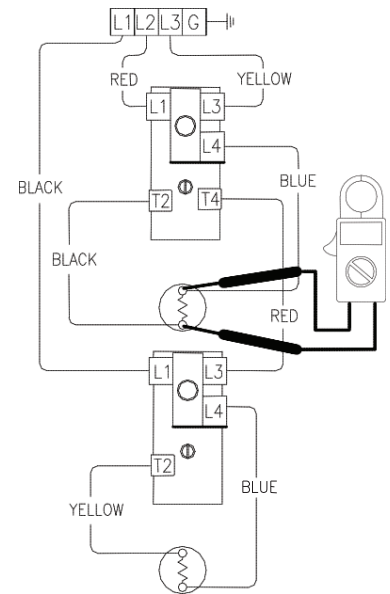

Figure 42

Tank Does Not Deliver Enough Hot Water.

1. This procedure assumes line voltage, ECO and elements are in working order.
2. Turn power "ON" to water heater and set multi-meter to "Volts AC."
3. Adjust temperature setting of upper & lower thermostat to the highest setting. Water temperature in tank must be below thermostat setting for this test.
4. See Figure 41 above. Check voltage across terminals L4 & T2 of upper thermostat.
 - A) Rated voltage IS present, okay, upper thermostat is calling for heat. Go to step 5 below.
 - B) Rated voltage NOT present, replace upper thermostat.
5. Adjust temperature setting of upper thermostat to the minimum setting. Water temperature in tank must be above thermostat setting for this test.
6. Check voltage across terminals L3 & T4 of upper thermostat (see Figure 43).
 - A) Rated voltage NOT present, replace upper thermostat.
 - B) Rated voltage IS present, upper thermostat is okay. Go to step 7 on next page.

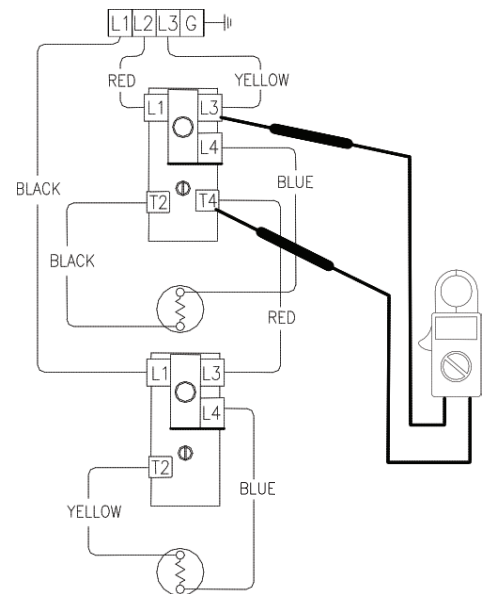

Figure 43

SERVICE PROCEDURE RE-IV
Light Duty Commercial
Thermostat Testing

Double Element, Non-Simultaneous, Three Phase Operation (continued).

⚠ WARNING
High voltage exposure. Use caution to avoid personal injury during this procedure.

Tank Does Not Deliver Enough Hot Water (continued).

7. Check voltage across terminal L1 of upper thermostat & T2 of lower thermostat. (see Figure 44).
 - A) Rated voltage NOT present, Replace lower thermostat.
 - B) Rated voltage is present, okay, go to step 8.
8. Check voltage across lower element (see Figure 45).
 - A) Rated voltage NOT present, check wire connections between thermostats & element.
 - B) Rated voltage IS present, repeat element testing see page 15.

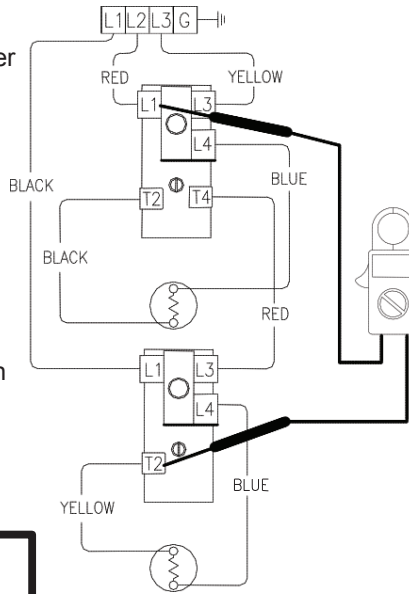

Figure 44

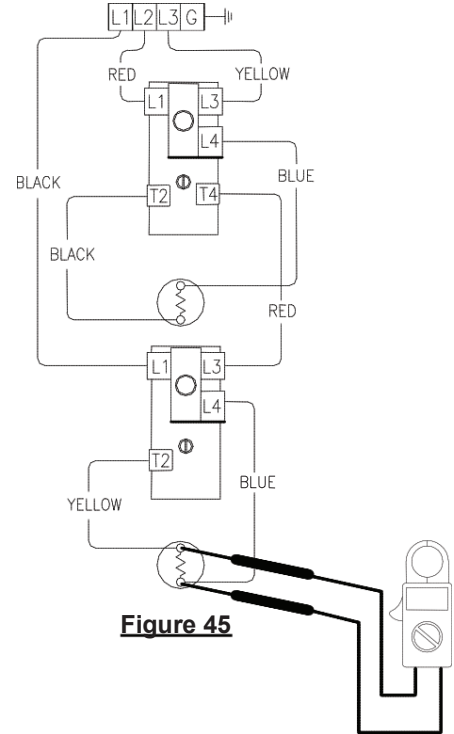

Figure 45

⚠ WARNING
Be sure thermostats are reset to their original temperature settings as found prior to thermostat testing

Water Temperature In Tank Is Above Thermostat Setting.

1. This procedure assumes line voltage, ECO and elements are in working order.
2. Adjust upper and lower thermostat to the lowest setting.
3. Turn power "ON" to water heater and Set multi-meter to "Volts AC."
4. See Figure 44 above. Check across terminal L1 of upper thermostat & T2 of lower thermostat.
 - A) Rated voltage IS present, replace lower thermostat.
 - B) Rated voltage NOT present, okay, go to step 5 below.
 - C) Lower than rated voltage IS present, recheck for grounded lower element.
5. Check across terminal L4 & T2 of upper thermostat (see Figure 46).
 - A) Rated voltage IS present, replace upper thermostat.
 - B) Rated voltage NOT present, upper thermostat is okay.
 - C) Lower than rated voltage IS present, recheck for grounded upper element, see page 15.

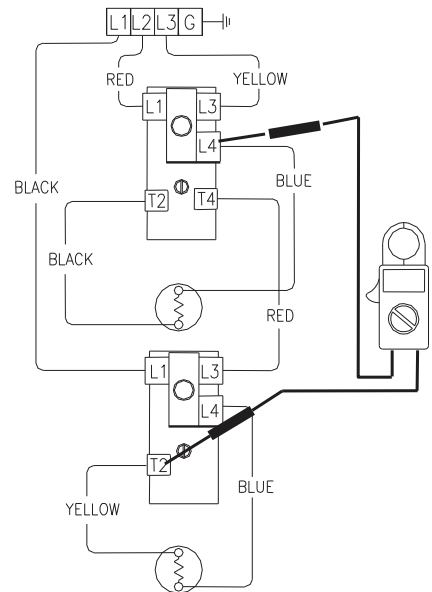

Figure 46

Double Element, Simultaneous, Three Phase Operation.

Water In Tank Is Cold Or Not Enough Hot Water With Power ON.

⚠ WARNING
High voltage exposure. Use caution to avoid personal injury during this procedure.

1. This procedure assumes line voltage, ECO and elements are in working order.
2. Adjust temperature setting for both thermostats to the highest setting.
3. Turn power "ON" to water heater.
4. Set multi-meter to "Volts AC."
5. Check across terminals L4 and T2 of upper thermostat (see Figure 47).

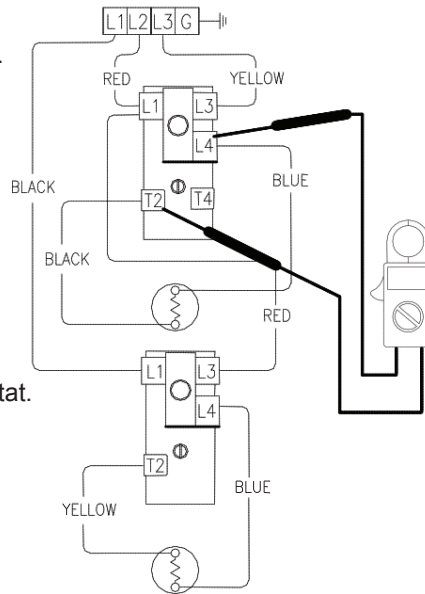

Figure 47

- A) Rated voltage NOT present, recheck upper ECO (see page 14). If ECO is okay, replace upper thermostat.
- B) Rated voltage IS present, proceed to next step.

6. Check across upper element terminals (see Figure 48).

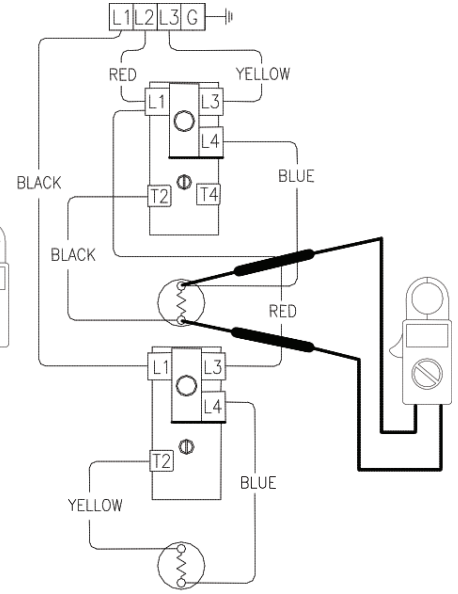

Figure 48

- A) Rated voltage NOT present, check wire connections from thermostat to upper element.
- B) Rated voltage IS present, repeat element testing see page 15

7. Check across terminal L4 of lower thermostat and T2 of lower thermostat (see Figure 49).

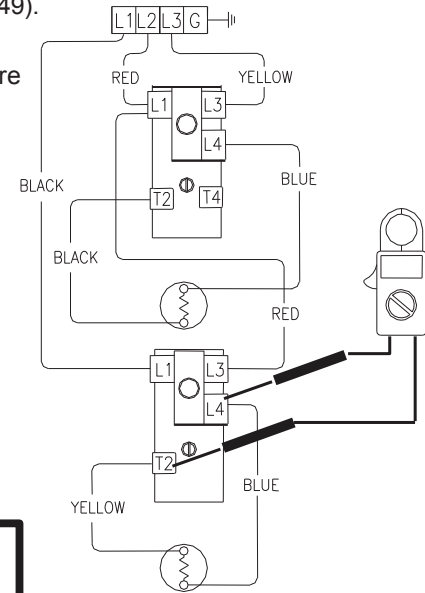

Figure 49

- A) Rated voltage NOT present, check ECO (see page 14) & wire connections at upper & lower thermostats. If okay, replace lower thermostat.
- B) Rated voltage IS present, proceed to next step.

8. Check across lower element terminals (see Figure 50).

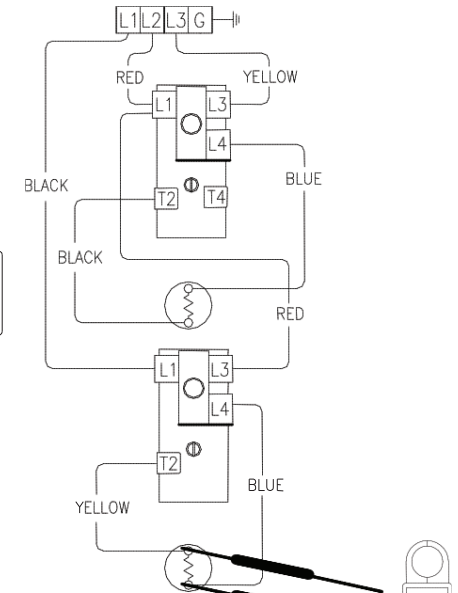

Figure 50

- A) Rated voltage NOT present, check lower element wire connections to thermostat.
- B) Rated voltage IS present, repeat lower element testing see page 15.

⚠ WARNING
Be sure thermostats are reset to their original temperature settings as found prior to thermostat testing

SERVICE PROCEDURE RE-IV
Light Duty Commercial
Thermostat Testing

Double Element, Simultaneous, Three Phase Operation (continued).

Water Temperature In Tank Is Above Thermostat Setting.

1. This procedure assumes line voltage, ECO and elements are in working order.
2. Adjust upper and lower thermostat to the lowest setting.
3. Turn power "ON" to water heater.
4. Set multi-meter to "Volts AC."
5. Check across terminals L4 and T2 of upper thermostat (see Figure 51).
 - A) Rated voltage IS present, replace upper thermostat.
 - B) Rated voltage NOT present, upper thermostat is okay. Go to step 6 below.
 - C) Lower than rated voltage IS present, recheck for grounded upper element see page 15.
6. Check across terminals L4 & T2 of lower thermostat (see Figure 52).
 - A) Rated voltage IS present, replace lower thermostat.
 - B) Rated voltage NOT present, lower thermostat is okay.
 - C) Lower than rated voltage IS present, recheck for grounded lower element.

⚠ WARNING
High voltage exposure. Use caution to avoid personal injury during this procedure.

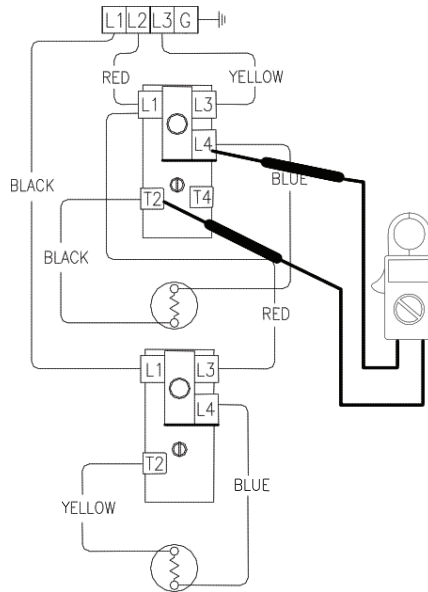

Figure 51

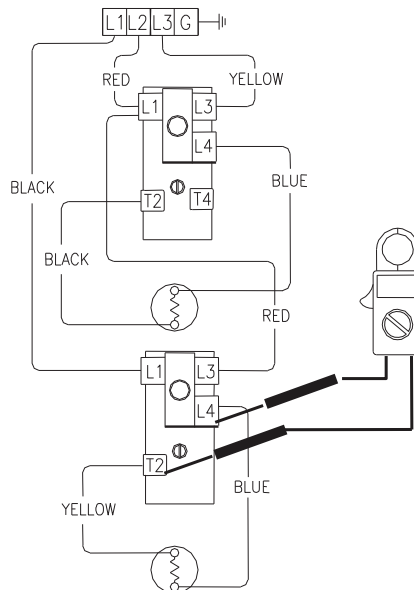

Figure 52

SERVICE PROCEDURE RE-VI

Heating Element Removal and Replacement

Heating Element Removal

1. Turn power "OFF" To water heater.
2. Turn off cold water supply to heater. Connect hose to drain spigot of water heater and route to an open drain. Open a nearby hot water faucet to vent heater for draining. Open drain spigot of water heater and allow heater to drain to a point below the element(s).
3. Close drain spigot and remove hose.
4. Remove access cover and insulation.
5. Remove plastic thermostat protector from thermostat.
6. Disconnect wires from element terminals.
7. Remove element from tank using 1-½ deep well socket or appropriate wrench. Unscrew element counter-clockwise to remove from tank.
8. Be sure to remove old element gasket from the tank. It is not recommended to be re-used.

Heating Element Replacement

1. Check element terminal block for proper electrical rating. NOTE: Some elements have dual ratings, be sure to check all surfaces of the element terminal block (see illustration below).
2. Apply new element gasket to the new element. Be sure gasket is seated flat against element flange without rolls or gaps (see illustration below).
3. Clean any debris from element fitting on tank. Lubricate element threads as needed with thread lubricant.
4. Thread new element clockwise into tank. Tighten element using 1-½ deep well socket or appropriate wrench. Do not over tighten, over tightening may damage element gasket.
5. Reconnect wires to element, be sure wires are snug and corrosion free. Do not over tighten, doing so may damage terminal block.
6. Resume water supply to heater, be sure tank is full of water and check for leaks.
7. Re-install plastic thermostat protector.
8. Re-install insulation and access cover.
9. To resume operation, **BE SURE TANK IS FULL OF WATER** and restore power to water heater. Verify proper heater operation.

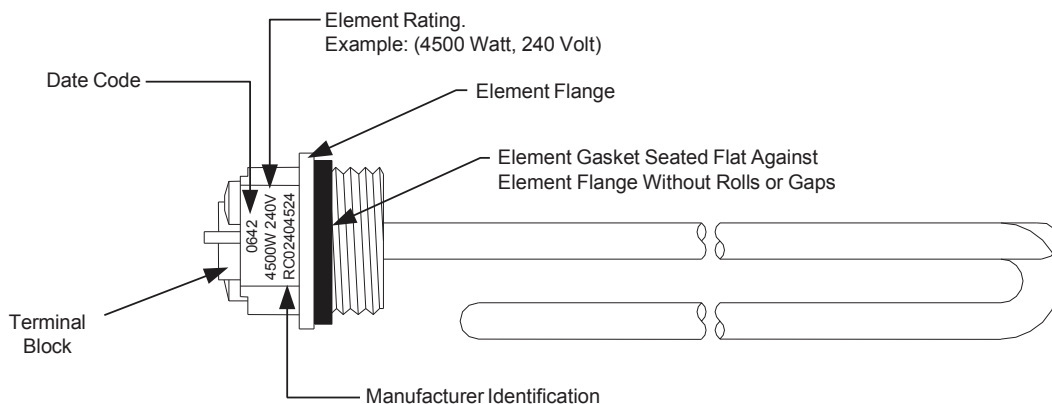

⚠ WARNING
High voltage exposure. Be sure power is
"OFF" when performing this procedure.

⚠ WARNING
Heater components and stored water may be
HOT when performing the following steps in
this procedure. Take necessary precaution to
prevent personal injury.

Diptube Inspection and Replacement

WARNING

Heater components and stored water may be HOT when performing the following steps in this procedure. Take necessary precaution to prevent personal injury.

- Step 1. Turn power "OFF" to water heater.
- Step 2. Turn off cold water supply to heater. Connect hose to drain spigot of water heater and route to an open drain. Open a nearby hot water faucet to vent heater for draining. Open drain spigot of water heater and allow heater to drain to a point below the inlet connection nipple.
- Step 3. Close drain spigot and remove hose.
- Step 4. Disconnect inlet nipple from plumbing system.
- Step 5. With an appropriate wrench, remove inlet nipple/dip tube from the water heater. Use caution not to damage nipple threads.
- Step 6. Visually inspect inlet nipple/dip tube. Inlet nipple/dip tube should be free of cracks and any blockage. Hydro-jets located near the bottom of the dip tube should be open and free of any blockage. Anti-siphon hole located approximately 6" from the bottom of nipple, should be free of any blockage.

Any damage such as cracks, restriction due to deformation or unintentional holes are not field repairable and the inlet nipple/dip tube must be replaced.
- Step 7. Upon completion of inspection or subsequent replacement, reinstall inlet nipple/dip tube into heater. Ensure pipe dope is used on the nipple's threads. Connect nipple to plumbing system, close spigot and remove drain hose, resume water supply and refill heater with water.
- Step 8. To resume operation, **BE SURE TANK IS FULL OF WATER** and turn power "ON" to water heater.

Anode Inspection and Replacement

- Step 1. Turn power "OFF" to water heater.
- Step 2. Turn off cold water supply to heater. Connect hose to drain spigot of water heater and route to an open drain. Open a nearby hot water faucet to vent heater for draining. Open drain spigot of water heater and allow heater to drain to a point below the outlet connection nipple.
- Step 3. Close drain spigot and remove hose.
- Step 4. Disconnect outlet nipple from plumbing system.
- Step 5. With an appropriate wrench, remove outlet nipple/anode from the water heater. Use caution not to damage nipple threads.
- Step 6. Visually inspect outlet nipple/anode. Outlet nipple/anode should show signs of depletion, this is normal. If depletion is $\frac{1}{2}$ of the original anode diameter (original diameter approximately $\frac{3}{4}$ "), replacement is recommended. If any of the steel core of the anode is exposed, replacement is recommended.
- Step 7. Upon completion of inspection or subsequent replacement, reinstall outlet nipple/anode into heater. Ensure pipe dope is used on the nipple's threads. Connect nipple to plumbing system, close spigot and remove drain hose, resume water supply and refill heater with water.
- Step 8. To resume operation, **BE SURE HEATER IS FULL OF WATER** and turn power "ON" to water heater.

Generic Parts List

TOP LOCATION

- Double element water heater, non-simultaneous single phase and three phase operation.

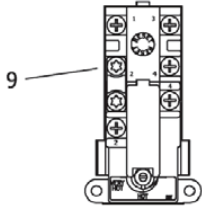

TOP LOCATION

- Double element water heater, simultaneous operation.

BOTTOM LOCATION

- Single element water heater.
- Double element water heater, non-simultaneous three phase operation.
- Double element water heater, simultaneous operation.

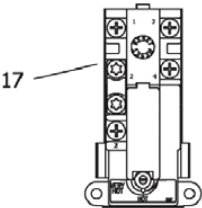

BOTTOM LOCATION

- Double element water heater, non-simultaneous single phase operation.

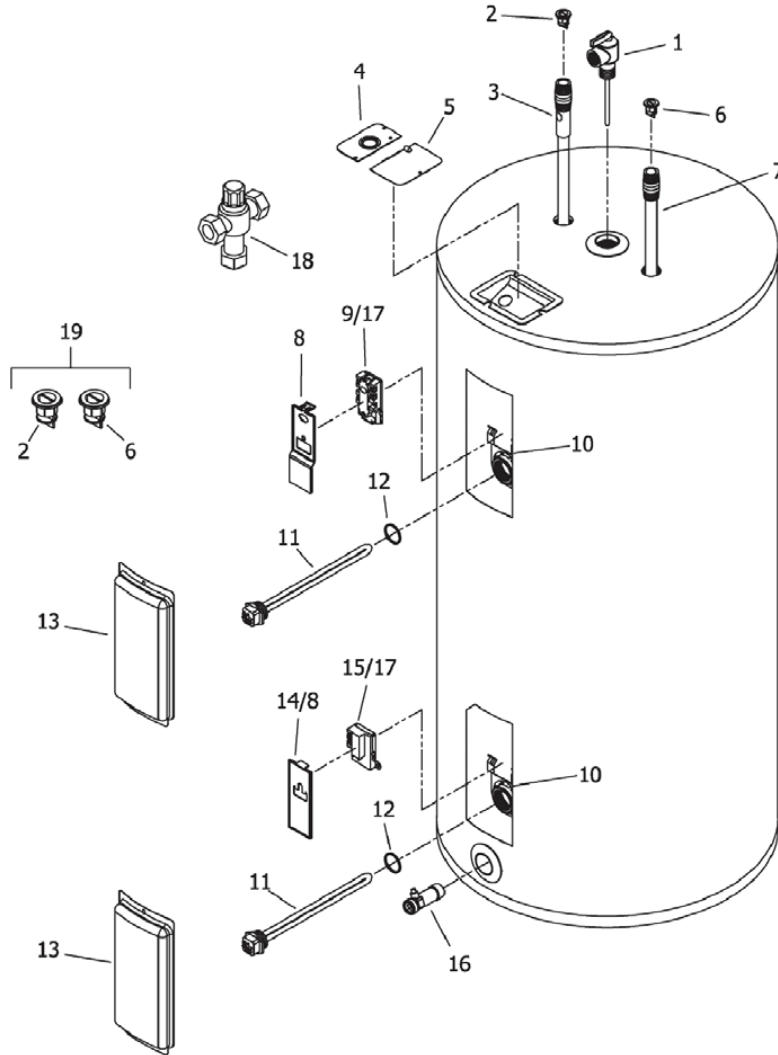
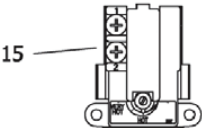

1. T&P Relief Valve
2. Heat Trap Insert (Outlet)
3. Hot Water Outlet/Anode
4. Cover Conduit/Ground
5. Junction Box Cover
6. Heat Trap Insert (Inlet)
7. Cold Water Inlet Diptube
8. Upper Thermostat Protector
9. Upper Thermostat
10. Thermostat Mounting Bracket

11. Heating Element
12. Element Gasket
13. Access Cover
14. Lower Thermostat Protector
15. Lower Thermostat (59T)
16. Brass Drain Valve
17. Thermostat w/High Limit (59T/66T)
18. ASSE Approved Mixing Device
19. Kit Heat Trap



United States

Sales 800-523-2931

Technical Support 800-334-3393

Email techserv@bradfordwhite.com

Warranty 800-531-2111

Email warranty@bradfordwhite.com

Service Parts 800-538-2020

Email parts@bradfordwhite.com

Canada

Sales & Technical Support 866-690-0961 905-203-0600

Fax 905-636-0666

Warranty bwccwarranty@bradfordwhite.com

Technical Support bwccotech@bradfordwhite.com

Service Parts orders@bradfordwhitecanada.com

Orders ca.orders@bradfordwhite.com

For U.S. and Canada field service,
contact your professional installer or
local Bradford White sales representative.

International

General Contact international@bradfordwhite.com

Quality People. Building Solutions.

Comfort Systems USA (Arkansas), Inc.
P.O. Box 16620
Little Rock, AR 72231
Phone 501-834-3320
Fax 501-834-5416

Date: 10/11/2023

Return Request: 10/22/2023

Project: Small & Associates – Tenant Finish Out

Supplier: Sanders Supply

Manufacturer: Bradford White

Submittal: Water Heater

Submittal Number:

Drawing # and Installation: Plumbing Drawings

ARCHITECT

Johnson Architects
2725 Cantrell Rd.
Little Rock, AR 72202
501-374-7700

ENGINEER

EECI, Inc.
10 Corporate Hill Drive, Suite 100
Little Rock, AR 72205
501-244-0511

GENERAL CONTRACTOR

Bailey Construction
2200 N. Rodney Parham Rd. #206
Little Rock, AR 72212
501-954-9201

MECHANICAL SUBCONTRACTOR

Comfort Systems USA (Arkansas), Inc.
9924 Landers Rd.
N. Little Rock, AR 72117
501-834-3320

Notes:

CSUSA PROJECT NO.

23-1026

jon@comfortar.com

Residential Utility Electric Water Heater



Photo is of
RE120U6

FEATURING:

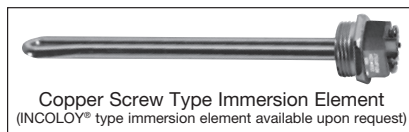

The Utility Electric Models Feature:

- **Fully Automatic Controls**—Fast acting surface-mount thermostat with high limit energy cut-off (manual reset) for safety.
- **Direct Heat Transfer With a Single Immersed Element**—Transfers heat directly and efficiently to the water. Screw-in style element.
- **Vitraglas[®] Lining with Microban[®]**—An exclusively engineered enamel formula that provides superior tank protection from the corrosive effects of water; and with Microban[®] antimicrobial product protection to help prevent the growth of bacteria, mold and mildew on the surface of the tank lining.
- **Insulation System**—1" (25mm) Non-CFC foam insulation covers the sides and top of the tank, reducing heat loss. This results in less energy consumption, improved efficiencies, and jacket rigidity.
- **Water Connections**—3/4" (19mm) NPT factory-installed true dielectric fittings extend water heater life and simplify water line connections. Located on the side for easier installation (Fittings packaged separately inside carton).
- **Protective Anode Rod**—Provides added protection against corrosion for long-term, trouble-free service.
- **Voltages Available**—120V, 208V, 240V, 277V, 480V.
- **Single Phase Operation Only.** ←
- **T&P Relief Valve**—installed.
- **Housing and Urban Development**—These water heaters are designed in accordance with H.U.D. and are approved for installation in a manufactured home (mobile home).



- Approved
- Approved as Noted
- Revise and Resubmit
- Rejected
- See Attached Review

Approval of Submittals is for general conformance with the design concept of the project and general compliance with the information given in the contract documents and does not relieve the contractor from the responsibilities for adherence to the contract. Contractor is responsible for confirming and correlation of all quantities and dimensions.

nkinder 10/17/2023 2:52:23 PM

Existing is 3-phase, 1-phase is readily available initially and as repair needed. Coordinate with electrician as a breaker change will be needed.

6 or 10-Year Limited Tank Warranties / 6 or 10-Year Limited Warranty on Component Parts.

For more information on warranty, please visit www.bradfordwhite.com

For products installed in USA, Canada, and Puerto Rico. Some states do not allow limitations on warranties. See complete copy of the warranty included with the heater.

Microban[®] antimicrobial product protection helps prevent the growth of bacteria, mold and mildew that may affect the product. The built-in antimicrobial properties do not protect users or others from disease-causing organisms. Microban[®] is a registered trademark of Microban Products Company.



Residential Utility Electric Water Heater

Utility Models

C.E.C. Listed

Model Number	Rated Nominal Capacity		Recovery at 90°F Rise*		A Floor to Heater Top in.	B Jacket Dia. in.	C Floor to Cold Water Conn. in.	D Floor to Hot Water Conn. in.	E Floor to T&P Conn. in.	F Floor to Anode Rod in.	G Water Conn. NPT in.	H Floor to Electrical Access in.	Approx. Shipping Weight lbs.
	U.S. Gal.	Imp. Gal.	U.S. GPH	Imp. GPH									
RE16U6†	6	5	7	6	16 ^{3/16}	14	2 ^{3/4}	9 ^{3/4}	9 ^{3/4}	N/A	3/4	16 ^{3/16}	35
RE110U6	10	8	7	6	17 ^{7/16}	16	5 ^{5/8}	14 ^{15/16}	13 ^{15/16}	9 ^{5/8}	3/4	12	44
RE112T6†	12	10	7	6	27 ^{5/16}	14	2 ^{3/4}	20 ^{5/8}	20 ^{5/8}	N/A	3/4	27 ^{5/16}	48
RE120U6	19	16	7	6	24 ^{7/16}	18	2 ^{3/4}	18 ^{3/16}	18 ^{3/16}	N/A	3/4	24 ^{7/16}	65

Model Number	Rated Nominal Capacity		Recovery at 50°C Rise*		A Floor to Heater Top mm.	B Jacket Dia. mm.	C Floor to Cold Water Conn. mm.	D Floor to Hot Water Conn. mm.	E Floor to T&P Conn. mm.	F Floor to Anode Rod mm.	G Water Conn. NPT mm.	H Floor to Electrical Access mm.	Approx. Shipping Weight kg.
	Liters		Liters/Hour										
RE16U6†	23		26		411	356	70	248	248	N/A	19	411	16
RE110U6	38		26		443	404	143	380	354	244	19	305	20
RE112T6†	45		26		694	356	70	524	524	N/A	19	694	22
RE120U6	72		26		621	457	70	462	462	N/A	19	621	29

† Maximum wattage at any voltage is 3000W.
 For 10 year models, change suffix "6" to "10".
 Single element only.

* Based on 1500W operation.

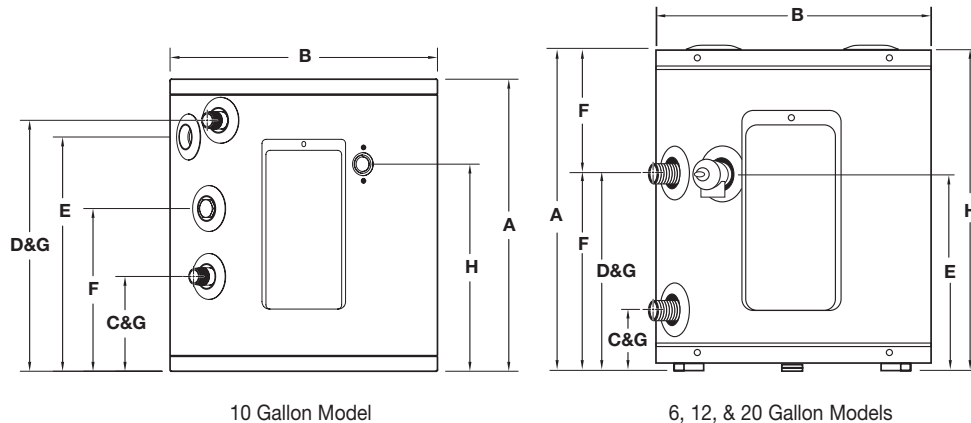

Wattage	Recovery GPH Temperature Rise °F				
	60	80	90	100	120
1500W	10	8	7	6	5
2000W	14	10	9	8	7
2500W	17	13	11	10	9
3000W	21	15	14	12	10
3500W	24	18	16	14	12
4000W	28	21	18	16	14
4500W	31	23	21	19	15
5000W	34	26	23	21	17
5500W	38	29	25	23	19
6000W	41	31	28	25	21

Wattage Limitations	Voltage			
	120V	208V	240V	277V 480V
1500W	yes	yes	yes	yes
2000W	yes	yes	yes	yes
2500W	yes	yes	yes	yes
3000W	yes	yes	yes	yes
3500W	no	yes	yes	no
4000W	no	yes	yes	yes
4500W	no	yes	yes	yes
5000W	no	yes	yes	yes
5500W	no	yes	yes	no
6000W	no	yes	yes	yes

General:

All models are exempt from NAECA requirements and ASHRAE Standard 90.1b. All models UL® listed. These heaters are wired Single Phase, 120V with one 1500W element, unless otherwise specified. All water and electrical connections are 3/4" (19mm) NPT. All models certified at 300 PSI test pressure (2068 kPa) and 150 PSI working pressure (1034 kPa). Applicable models CSA-verified for energy performance in accordance with C191.1-M90.

Dimensions and specifications subject to change without notice in accordance with our policy of continuous product improvement.

— BRADFORD WHITE IS —



Sales: 800-523-2931 ■ Fax 215-641-1612

24/7 Technical Support: 800-334-3393 ■ Email techserv@bradfordwhite.com

Products made by Bradford White are manufactured in the United States using the finest raw materials and components from around the world.

Built to be the Best