

*Quality People. Building Solutions.*

Comfort Systems USA (Arkansas), Inc.  
P.O. Box 16620  
Little Rock, AR 72231  
Phone 501-834-3320  
Fax 501-834-5416

**Date:** 5/9/2023

**Return Request:** 5/18/2023

**Project:** Little Rock Convention Center – Atrium

**Supplier:** Airetech

**Submittal:** Terminal Heat Transfer Units (FCU-1)

**Submittal Number:** 23 82 19-01

**Drawing # and Installation:** Mechanical Drawings

**ARCHITECT**

Witsell Evans Rasco  
901 West Third Street  
Little Rock, AR 72201  
501-374-5300

**ENGINEER**

Pettit & Pettit  
201 E. Markham, Suite 400  
Little Rock, AR 72201  
501-374-3731

**GENERAL CONTRACTOR**

Wagner General Contractor  
600 W. Race Ave.  
Searcy, AR 72143  
501-203-0704

**MECHANICAL SUBCONTRACTOR**

Comfort Systems USA (Arkansas), Inc.  
9924 Landers Rd.  
N. Little Rock, AR 72117  
501-834-3320

Notes:

**CSUSA PROJECT NO.**

**23-1015**

[jon@comfortar.com](mailto:jon@comfortar.com)



## **Installation, Operation and Maintenance Manual**

**EQUIPMENT:** IEC Lowboy Fan Coil Unit

**PROJECT:** Little Rock Statehouse Convention Center East Lobby  
Atrium Renovation

**LOCATION:** Little Rock, AR

**MECHANICAL  
CONTRACTOR:** Comfort Systems, USA

**SUBMITTED BY:** Forrest Moseley  
[forrest@airetechcorp.com](mailto:forrest@airetechcorp.com)  
(501) 280-0404

---

**Job # 73503**



A **NIBE** GROUP MEMBER

# Fan Coils

## INSTALLATION, OPERATION, & MAINTENANCE MANUAL

### Horizontal, Vertical, Hi-Performance



- Energy Efficient
- Easy to Install
- Extended Service Life

# Fan Coils

## INSTALLATION, OPERATION, & MAINTENANCE MANUAL

---

It is the responsibility of the end user to properly characterize and dispose of all waste materials according to applicable regulatory and legal entities. Where reasonable, safe, and compliant with local regulatory and legal requirements, IEC encourages recycling materials when disposing of its products.

International Environmental Corporation (IEC) works continually to improve its products. As a result, the design and specifications of each product may be changed without notice and may not be as described herein. Please contact IEC for information regarding current design and product specifications. Statements and other information contained herein are not express warranties and do not form the basis of any bargain between the parties but are merely IEC's opinion or commendation of its products. Manufacturer's standard limited warranty applies.



## Table of Contents

### SECTION ONE — Installation

- 4 Preface
- 4 Unpacking and Inspection
- 5 Prepare Jobsite and Units
- 5 Handling and Installation
- 6 Unit Clearance and Service Access
- 11 Vertical Series Unit Installation
- 12 Cabinet Front Panel Installation and Removal
- 13 Decorative Wall Panels Installation (FHA)
- 14 Optional Trim Kit Installation
- 14 Rear Cabinet Extension Installation (Vertical Floor)
- 15 Cooling/Heating Connections
- 17 Electrical Connections
- 20 Ductwork Connections
- 21 Final Preparations

---

### SECTION TWO — Start-Up

- 22 General Start Up
- 22 Cooling/Heating System
- 23 Direct Expansion (DX) Systems
- 23 Air System Balancing
- 23 Maximum External Static Pressures
- 24 Water Treatment
- 24 Water System Balancing

### SECTION THREE — Controls Operation

- 25 Board Components and Specifications
- 27 Board Function and Diagnostics
- 32 LED Functions and Outcomes (sequence of operations)
- 33 Board Generic Wiring Diagram

---

### SECTION FOUR — Normal Operation and Maintenance

- 34 General
- 34 Motor/Blower Assembly
- 34 Bipolar Ionizer Brush Cleaning
- 34 Coil
- 35 Electric Heater Assembly
- 35 Electrical Wiring and Controls
- 36 Valves and Piping
- 36 Filters, Throwaway
- 36 Filters, Permanent
- 36 Drain
- 37 Replacement Parts

---

### SECTION FIVE — Equipment Start-Up

- 38 Check List - IMPORTANT
- 39 Appendix A – 3-Speed Pot Board
- 40 Terms and Conditions

### SECTION ONE — Installation

#### Preface

International Environmental Corporation fan coil units represent a prudent investment offering trouble-free operation and long service with proper installation, operation, and regular maintenance. Your equipment is initially protected under the manufacturer's standard warranty; however, this warranty is provided under the condition that the steps outlined in this manual for initial inspection, proper installation, regular periodic maintenance, and everyday operation of the equipment be followed in detail. This manual should be fully reviewed in advance before initial installation, start-up, and any maintenance. Should any questions arise, please contact your local Sales Representative or the factory BEFORE proceeding.

The equipment covered by this manual is available with a variety of options and accessories. Consult the approved unit submittals, order acknowledgment, and other manuals for specific details on unit options and accessories.

No attempt should be made to handle, install, or service any unit without following safe practices regarding mechanical equipment.

The equipment must always be properly supported. Temporary supports used during installation or service must be adequate to hold the equipment securely.

All power must be disconnected before any installation or service is attempted. More than one power source may be supplied to a unit. Power to remote mounted control devices may not be supplied through the unit.

Never wear bulky or loose-fitting clothing when working on any mechanical equipment. Gloves should always be worn for protection against heat and other possible injuries. Safety glasses or goggles should always be worn, especially when drilling, cutting, or working with chemicals such as refrigerants or lubricants.

Never pressurize any equipment beyond specified test pressures as shown on unit rating plate. Always pressure test with an inert fluid or gas such as clear water or dry nitrogen to avoid possible damage or injury in the event of a leak or component failure during testing.

Always protect adjacent flammable material when welding or soldering. Use a suitable heat shield material to contain sparks or drops of solder. Have a fire extinguisher readily available.

All mechanical and electrical connections should be made by authorized personnel in accordance with National and local codes where applicable. The manufacturer assumes no responsibility for personal injury or property damage resulting from improper or unsafe practices during the handling, installation, service, or operation of any equipment.

**This appliance is not intended for use by persons (including children) with reduced physical, sensory, or mental capabilities, or lack of experience and knowledge, unless they have been given supervision or instruction concerning use of the appliance by a person responsible for their safety.**

#### Unpacking and Inspection

All units are carefully inspected at the factory throughout the manufacturing process under a strict detailed quality assurance program. All major components and sub-assemblies are carefully tested for proper operation and verified for full compliance with factory standards. Operational testing of some customer-furnished components such as control valves and electronic control items may be a possible exception.

Each unit is carefully packaged for shipment to avoid damage during normal transit and handling. Equipment should always be stored in a dry and covered location and in the proper orientation as marked on the carton.

All shipments are made F.O.B. factory and it is the responsibility of the receiving party to inspect the equipment upon arrival. Any obvious damage to the carton and/or its contents should be recorded on the bill of lading and a claim should be filed with the freight carrier.

After determining the condition of the carton exterior, carefully remove each unit from the carton and inspect for hidden damage. At this time, check to make sure that factory provided items such as valve packages and actuators, switches, thermostats, drip lips, etc., are accounted for. Any hidden damage should be recorded

### SECTION ONE — Installation, Cont'd.

and immediately reported to the carrier and a claim filed. In the event a claim for shipping damage is filed, the unit, shipping carton, and all packing must be retained for physical inspection by the freight carrier. All equipment should be stored in the factory shipping carton with internal packing in place until installation.

At the time of receipt, the equipment type and arrangement should be verified against the order documents. Should any discrepancy be found, the local IEC Factory Representative should be notified immediately so that proper action may be taken.

**NOTE:** Should any questions arise concerning warranty repairs, the factory must be notified BEFORE any corrective action is taken.

#### Prepare Jobsite and Units

To save time and to reduce the possibility of costly errors, set up a complete sample installation in a typical room at the jobsite. Check all the critical dimensions such as field piping, wiring, and duct connection to ensure they agree with job requirements. Refer to job drawings and product dimension drawings as required. Instruct all trades in their part of the installation. Should any discrepancies be discovered, contact your local representative before continuing with unit installations.

For each unit, confirm incoming and control power requirements match available power source. Refer to unit nameplate and wiring diagram.

1. Check all tags on unit to determine if shipping screws are to be removed. Remove screws as directed.
2. Rotate the fan wheel by hand to ensure that the fan is unrestricted and can rotate freely. Check for shipping damage and fan obstructions. Adjust blower wheel as required.
3. Perform "Dry Fit" of valve assembly that may be shipped unattached to unit coil assembly. Should any questions arise on fit up please contact your local representative immediately.

#### Handling and Installation

While all equipment is designed and fabricated with sturdy materials, and may present a rugged appearance, great care must be taken to assure that no force or pressure be applied to the coil, piping or drain stub-outs during handling. Also, depending on the options and accessories, some units could contain delicate components that may be damaged by improper handling. Wherever possible, all units should be maintained in an upright position, and handled by the chassis, plenum sections, or as close as possible to the mounting-point locations. In the case of a full cabinet unit, the unit must obviously be handled by the exterior casing. This is acceptable providing the unit is again maintained in an upright position, and no force is applied that may damage internal components or painted surfaces.

The equipment covered in this manual **IS NOT** suitable for outdoor installations. The equipment should never be stored or installed where it may be subjected to a hostile environment such as rain, snow, or extreme temperatures.

Before, during, and after installation, special care must be taken to prevent foreign material such as paint, plaster, and drywall dust from being deposited in the drain pan or on the motor or blower wheels. Failure to do so may have serious adverse effects on unit operation, and in the case of the motor and blower assembly, may result in immediate or premature failure. All manufacturer's warranties are void if foreign material is allowed to be deposited in the drain pan or on the motor or blower wheels of any unit. Some units and/or job conditions may require some form of temporary covering during construction.

### SECTION ONE — Installation

#### Unit Clearance and Service Access

For specific unit dimensions, refer to the product technical catalog for your model. Provide adequate clearance for the removal of the panel, access to controls or replacement of internal serviceable components including air filters. Allow clearances according to local and national codes.

#### Vertical F\*A Service & Operating clearances

NOTE – Figures 1 and 2 clearances also applicable for obsolete F\*C and F\*Y floor families

Service access is available from the front on vertical units. Cabinet and recessed units have removable front panels to allow access to the unit.

Units have either right or left hand piping. Reference piping locations by facing the front of the unit (airflow discharges from the front). The control panel is always on the end opposite the piping, unless otherwise specified.

Table 1. Vertical Floor F\*A

Size	Dimensions – inches (mm)	
	FHA	FXA/FSA
02	23-1/2 (597)	41 (1041)
03	27-1/2 (699)	45 (1143)
04	33-1/2 (851)	51 (1295)
06	43-1/2 (1105)	61 (1549)
08	45-1/2 (1156)	63 (1600)
10	59-1/2 (1511)	77 (1956)
12	67-1/2 (1715)	85 (2159)

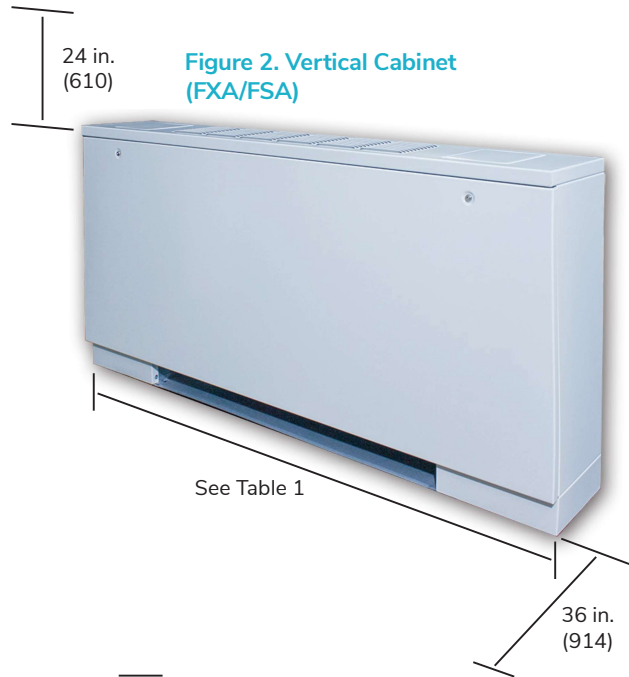

Figure 1. Vertical Concealed (FHA)

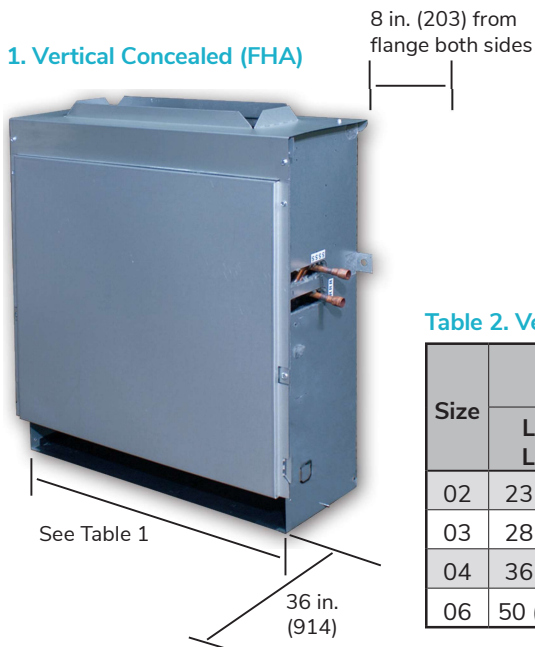
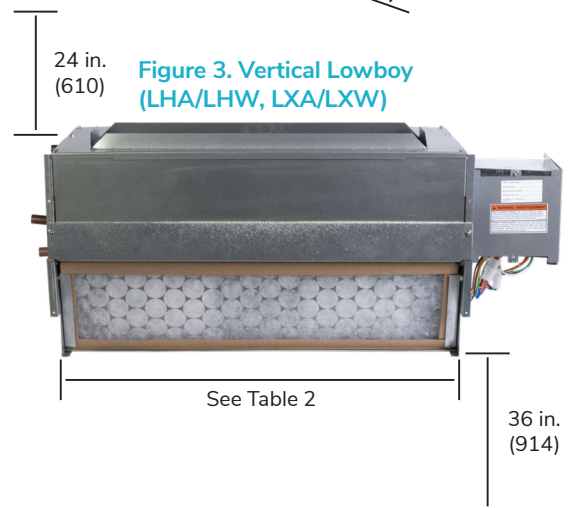

Table 2. Vertical Lowboy L\*\*

Size	Dimensions – inches (mm)	
	LHA/LHW	LXA/LXW
02	23 (584)	41 (1041)
03	28 (711)	46 (1168)
04	36 (914)	54 (1372)
06	50 (1270)	68 (1727)



### Horizontal Ceiling Unit Clearance and Service Access Clearance

Units have either right or left hand piping. Reference piping locations by facing the front of the unit (airflow discharges from the front). The control panel is always on the end opposite the piping, unless otherwise specified.

**Table 3. Horizontal Ceiling Drain Pan or Coil Removal Minimum Service Clearance Width**

Size	Dimensions – inches (mm)				
	CHY/CPY standard drain pan	CHY/CPY extended drain pan	CPY Same Side Piping & Controls Extended Drain Pan	CBY	CXB
02	21-1/4 (540)	31-1/4 (794)	34 (864)	37 (940)	38 (965)
03	25-1/4 (641)	35-1/4 (895)	38 (995)	37 (940)	42 (1067)
04	31-1/4 (794)	41-1/4 (1048)	44 (1118)	43 (1092)	48 (1219)
06	36-1/4 (921)	46-1/4 (1175)	49 (1245)	55 (1397)	53 (1346)
08	43-1/4 (1099)	53-1/4 (1353)	56 (1422)	55 (1397)	60 (1524)
10	57-1/4 (1454)	67-1/4 (1708)	70 (1778)	77 (1956)	74 (1880)
12	65-1/4 (1657)	75-1/4 (1911)	78 (1981)	77 (1956)	83 (2083)

**Figure 4. CPY Unit Clearance and Service Access**

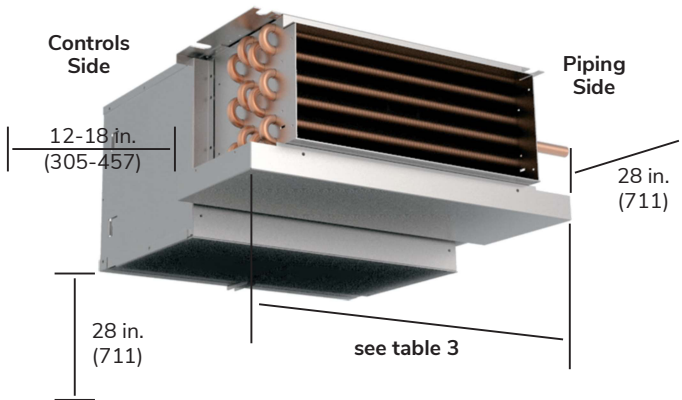

**Figure 6. CXB Unit Clearance Service Access**

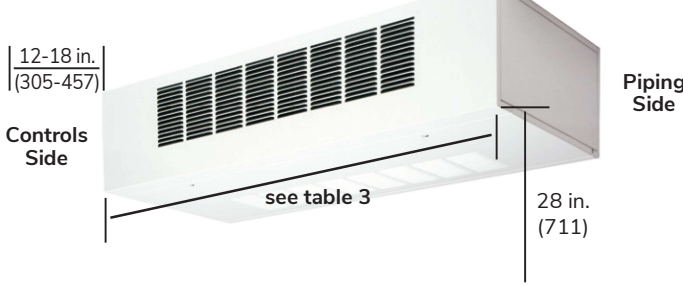

**Figure 5. CHY Unit Clearance Service Access**

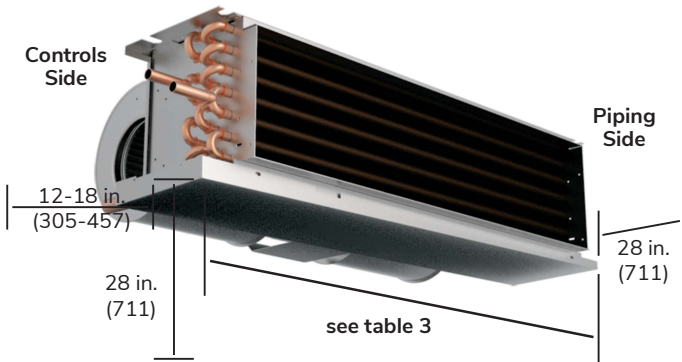

**Figure 7. CBY Unit Clearance and Service Access**





# Fan Coils

## INSTALLATION, OPERATION, & MAINTENANCE MANUAL

### SECTION ONE — Installation, Cont'd.

#### Hi-Performance Unit Clearance and Service Access Clearance

Units have either right or left hand piping. Reference piping locations by facing the front of the unit (airflow discharges from the front). The control panel is always on the end opposite the piping, unless otherwise specified.

Table 4. Hi-Performance Drain Pan or Coil Removal Minimum Service Clearance Width

Size	Dimensions – inches (mm)				
	HHY/HPY standard drain pan	HHY/HPY extended drain pan	HLY	HXY	VEY
06	23 (584)	32 (813)	31 (787)	31 (787)	21 (533)
08	28 (711)	37 (940)	36 (914)	36 (914)	26 (660)
10	32 (813)	42 (1067)	40 (1016)	40 (1016)	30 (762)
12	37 (940)	47 (1194)	45 (1143)	45 (1143)	35 (889)
14	42 (1067)	52 (1321)	50 (1270)	50 (1270)	40 (1016)
16	47 (1194)	56 (1422)	55 (1397)	55 (1397)	45 (1143)
18	52 (1321)	62 (1575)	60 (1524)	60 (1524)	50 (1270)
20	56 (1422)		64 (1626)	64 (1626)	54 (1372)

Figure 8. HPY Unit Clearance and Service Access

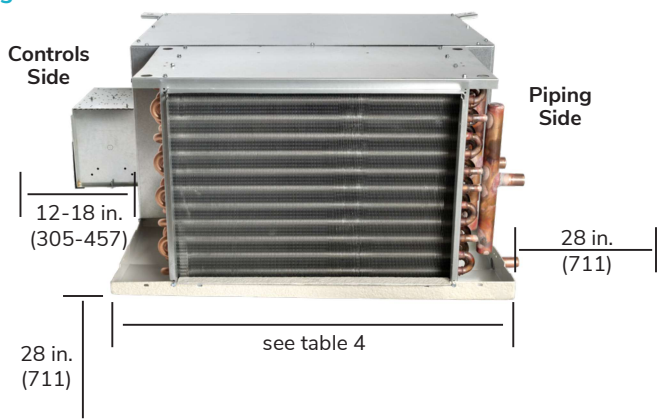

Figure 10. HHY Unit Clearance and Service Access

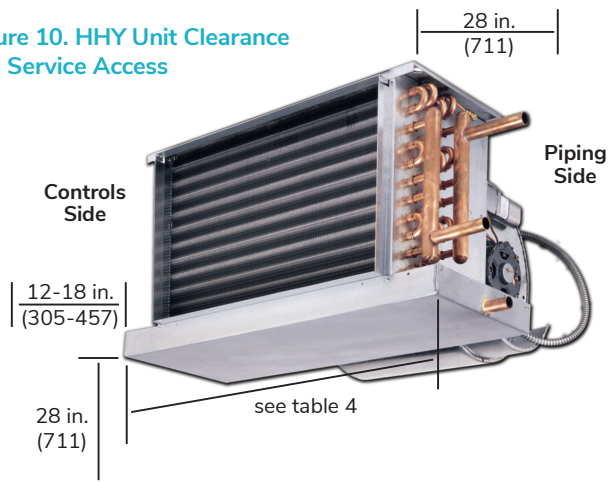

Figure 9. HXY Unit Clearance and Service Access



Figure 11. HLY Unit Clearance and Service Access



### SECTION ONE — Installation, Cont'd.

#### VEY Clearance

Figure 12. VEV Unit Clearance and Service Access

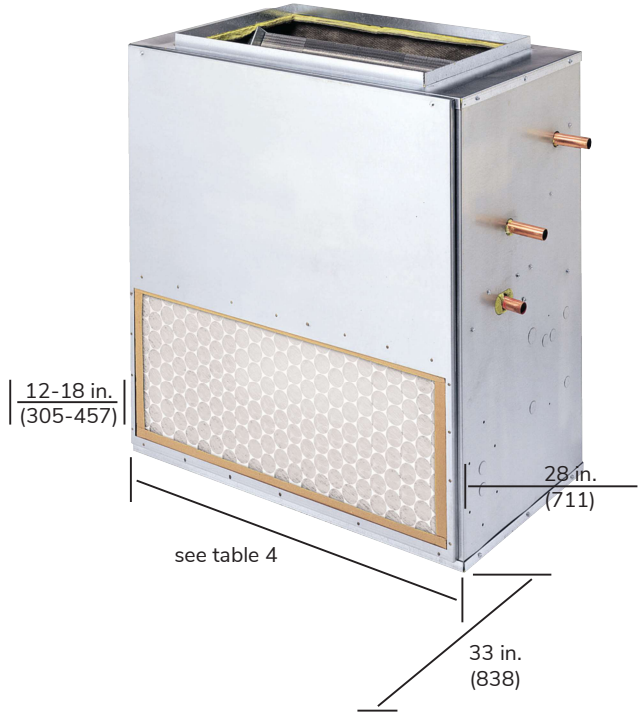

#### Horizontal Ceiling and Hi-Performance Ceiling Unit Installation

**CBY, CHY, CPY, CXB, HHY, HLY, HPY, HXY**

Anchoring the equipment in place is accomplished by using the mounting points provided with 3/8 inch all-thread rod and other hardware (not supplied with unit). The unit must be positioned so that the coil is on a LEVEL PLANE. Care must be taken to ensure that the drain pan does not slope away from the outlet connection.

Other field-furnished mounting devices such as rubber-in-shear or spring-type vibration isolators selected by the contractor or engineer may be substituted for the factory grommets and should be used where factory grommets are not provided. Refer to the device manufacturer for installation instructions.

It should be noted that unacceptable system operating characteristics and/or performance may result from improper or inadequate unit structural support. Adequate clearance must be provided for service and removal of the equipment and any accessory components.

Table 5. Threaded Rod Recommendations

Model	Rod Diameter	Rod Qty
C*Y 02, 03, 04, 06, 08,10,12	3/8" (9.5 mm)	4
H*Y 06, 08, 10, 12, 14, 16, 18, 20	3/8" (9.5 mm)	4
HPY 06, 08, 10, 12, 14, 16, 18, 20	3/8" (9.5 mm)	6

\*NOTE – Threaded rods and hardware are provided by others.

Refer to the unit product drawings for mounting hole locations and sizes.

On certain units, shipping screws or braces must be removed after the unit is installed. Be sure to check all tags on the unit to determine which, if any, of these devices need to be removed.

Figure 13. Thread Rod Suspension\*

\*NOTE – Figure depicts CHY. Threaded rods and hardware are provided by others.

Horizontal open coil unit models HHY or CHY may be mounted using the neoprene grommets provided.

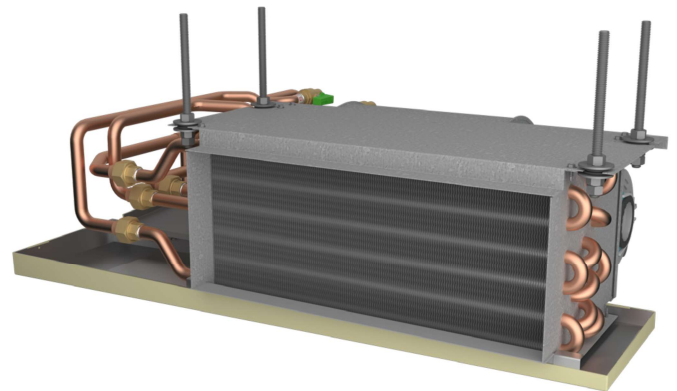

### SECTION ONE — Installation, Cont'd.

**Figure 14. Threaded Rod Suspension\***

\*NOTE – Figure depicts HPY. Threaded rods and hardware are provided by others.

Plenum-type unit model HPY should be mounted using the four hanger points on the coil and two hanger points on the plenum.

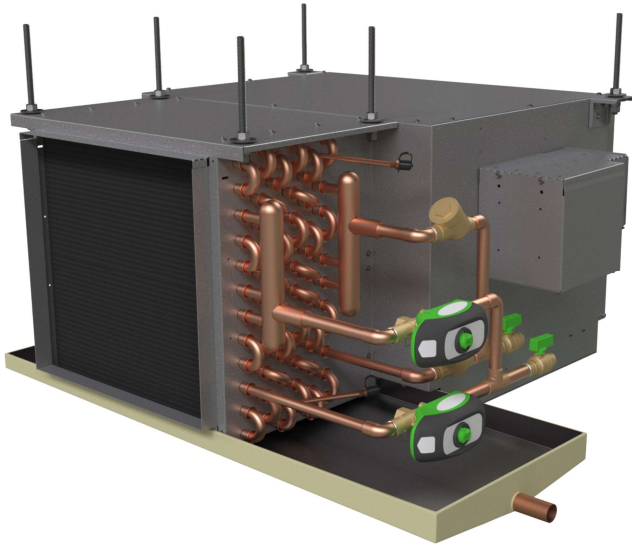

**Figure 15. Channel Mount Suspension\***

\*NOTE – Figure depicts CBY. Hanger rails and hardware are provided by others.

Cabinet unit models CBY and CXB may be mounted using four neoprene grommets provided in the four hanger holes in the case top.

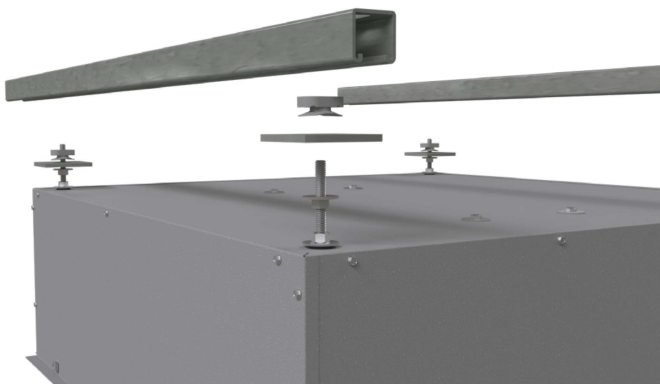

**Figure 16. Hanger Rails Mount**

\*NOTE – Figure depicts HXY. Threaded rods and hardware are provided by others.

Cabinet unit models HXY and HLY may be suspended using the neoprene grommets provided.



#### Drip Lip Installation

1. Locate where the Drip Lip will be installed.  
The supplied Drip Lip should be installed on the drain tube side of the coil assembly for CPY/CHY/ CBY/CXB units with factory supplied valve packages. The optional drain pan side mounting location may be used for CPY/CHY units that do not have factory supplied valve packages. (Figures 18, 20.)

**NOTE: The mounting holes on the drain pan may be partially concealed by insulating spray foam. Either the round or slotted through-holes on the Drip Lip can be used for installation.**

2. Secure the Drip Lip to the Drain pan using (2) of the included #8 x 3/8 inch (9.5 mm) screws. (See image of unit matching your unit/Drip Lip.)



### SECTION ONE — Installation, Cont'd.

Figure 17. Left-hand extension drip lip.

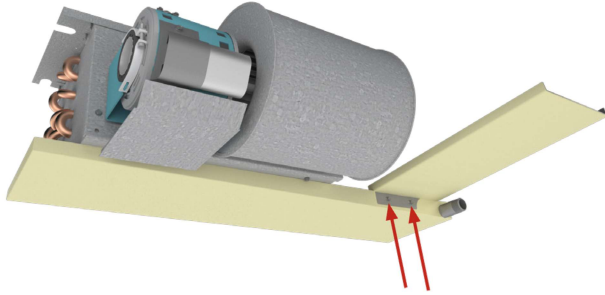

Figure 18. Left-hand side drip lip (without valve package).

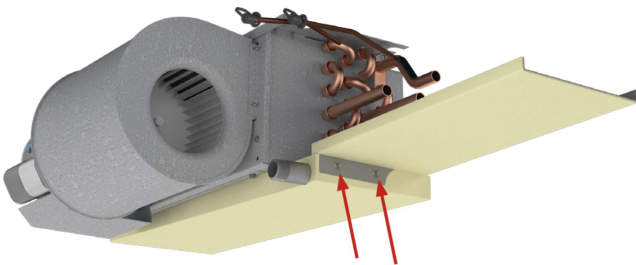

Figure 19. Right-hand extension drip lip.

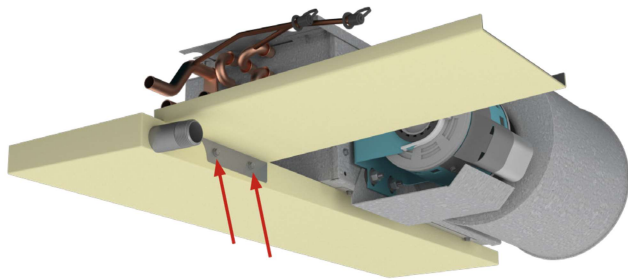
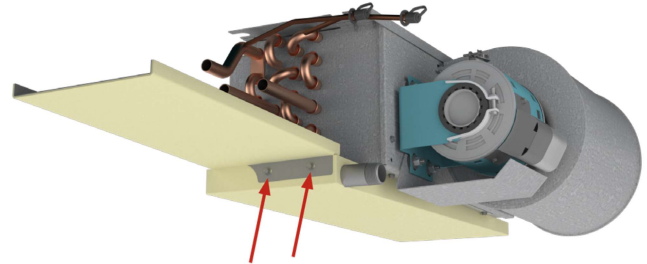

Figure 20. Right-hand side drip lip (without valve package).



#### VEY Hi-Performance Unit Installation

##### VEY

Hi-Performance vertical closet units VEV are designed to be floor mounted or otherwise supported from below and may be anchored directly through the cabinet floor or the optional 6-inch legs.

1. Select the unit location. Allow for adequate space for free air circulation, service clearances, piping and electrical connections, and any necessary ductwork.
2. Make sure the floor is able to support the weight of the unit. See submittal drawings for nominal unit weight.

#### Vertical Series Unit Installation

##### FHA

Vertical unit models are designed to be floor mounted or otherwise supported from below and bolted to the wall or floor structure through the mounting holes provided in the chassis. These units may be wall hung only when originally ordered from the factory for wall-mount applications.

The type of mounting device is a matter of choice; however, the mounting point shall always be that provided in the chassis or cabinet. Fasteners and other required hardware must be field-supplied. Refer to the unit product drawings for hole mounting locations and sizes.

### SECTION ONE — Installation, Cont'd.

#### Floor Mount

NOTE – Floor Mount instructions also applicable for obsolete F\*C and F\*Y floor families.

1. Select the unit location. Allow for adequate space for free air circulation, service clearances, piping and electrical connections, and any necessary ductwork.
2. Make sure the floor is able to support the weight of the unit. See submittal drawings for nominal unit weight.
3. Ensure wall behind unit is smooth and plumb; if necessary, install furring strips on walls with irregular surfaces or mullions. Furring strips must be positioned behind mounting holes in unit. Fasteners, furring strips, and other seals (if required) must be field-supplied.
4. Remove all wall and floor moldings from behind the unit.
5. Adjust optional unit leveling legs so unit is level. Unit must be level for proper operation and condensate drainage.

#### Cabinet Front Panel Installation and Removal

For FXA/FSA cabinet units, replace the front panel by aligning the bottom tabs on the unit with the respective slots on the panel bottom. Align the top edge of the unit with the panel.

#### Wall Mount

Figure 21. Wall Mount Hanger Hole Locations – FHA

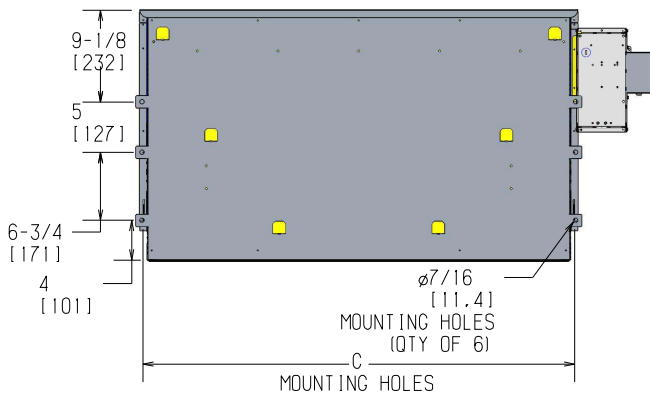

Figure 22. Wall Mount Hanger Hole Locations – FXA, FSA

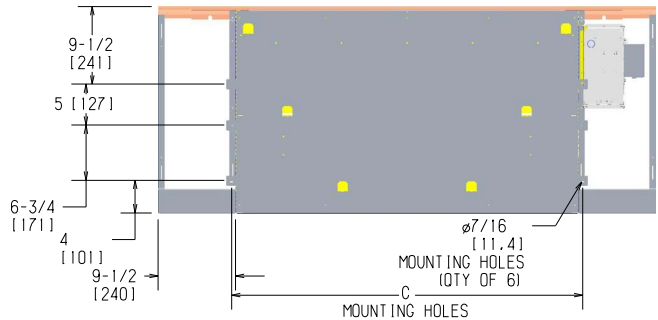

Table 6. C dimension for Wall Mount Hanger Hole Locations

Unit Model	C
02	23 (584)
03	27 (686)
04	33 (838)
06	43 (1092)
08	45 (1143)
10	59 (1499)
12	67 (1702)

1. Prepare wall openings for recessed units. Reference submittal drawings for unit size dimensions.
2. Mark the position of the hanger holes on the wall according to the dimensions provided in Figures 21 or 22. Align the hole locations evenly.
3. Prepare the field-provided installation hardware before setting the unit in place.
4. For Cabinet Units, remove the front panel before installation.
5. Mount the unit on the hanger hardware. Test to verify the unit is properly supported.
6. Complete piping and wiring connections, in addition to any necessary ductwork to the unit as instructed in the following sections. Ensure that the auxiliary drain pan is in position for coil drain, when applicable.
7. Reinstall the front panel (cabinet units) before start-up.

### SECTION ONE — Installation, Cont'd.

#### Decorative Wall Panels Installation (FHA)

NOTE – Decorative wall panel instructions also applicable for obsolete FHC floor model. For FHY, contact the factory.

The FHA model is a fully recessed and built into the wall of the conditioned areas. They cover the recess opening on all sides and are easily removed for access to the unit.

A top, bottom, and side framing studs are required to properly secure the wall panel to the dry wall. Reference Figures 25 and 26 for install diagram requirements. Secure the wall panel to the framing studs with field supplied mounting hardware

NOTE - For Style W and Z wall panels, once the wall panel frame is secured to the wall, install the panel and secure to the frame with the factory provided quarter turn camlocks.

Figure 24. Style Z Framed Wall Panel

Dimensions provided in inches (mm)

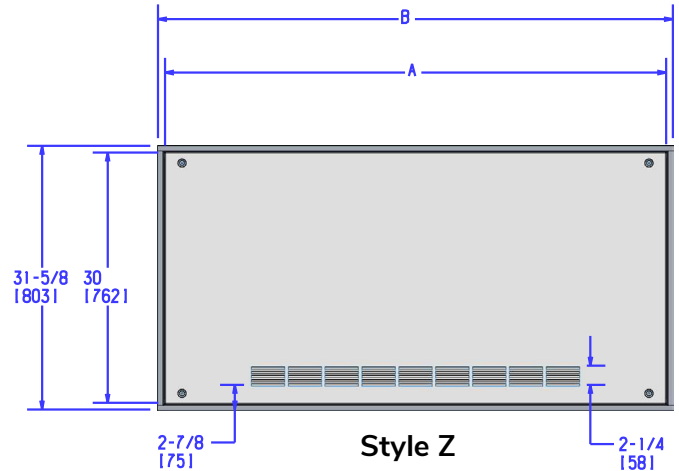

Table 7. Style W & Z Framed Wall Panel Dimensions

Nominal CFM	Panel Width (A) Inches (mm)	Frame Width (B) Inches (mm)	Wall Opening Inches (mm)	
			Width	Height
200	40" (1016)	41-3/4" (1061)	40-3/8" (1026)	30-1/4" (768)
300	40" (1016)	41-3/4" (1061)	40-3/8" (1026)	30-1/4" (768)
400	50" (1270)	51-3/4" (1315)	50-3/8" (1280)	30-1/4" (768)
600	60" (1524)	61-3/4" (1569)	60-3/8" (1534)	30-1/4" (768)
800	62" (1575)	63-3/4" (1619)	62-3/8" (1585)	30-1/4" (768)
1000	76" (1930)	77-3/4" (1975)	76-3/8" (1940)	30-1/4" (768)
1200	84" (2134)	85-3/4" (2178)	84-3/8" (2143)	30-1/4" (768)

Figure 25. Style W Framed Wall Panel Install Diagram

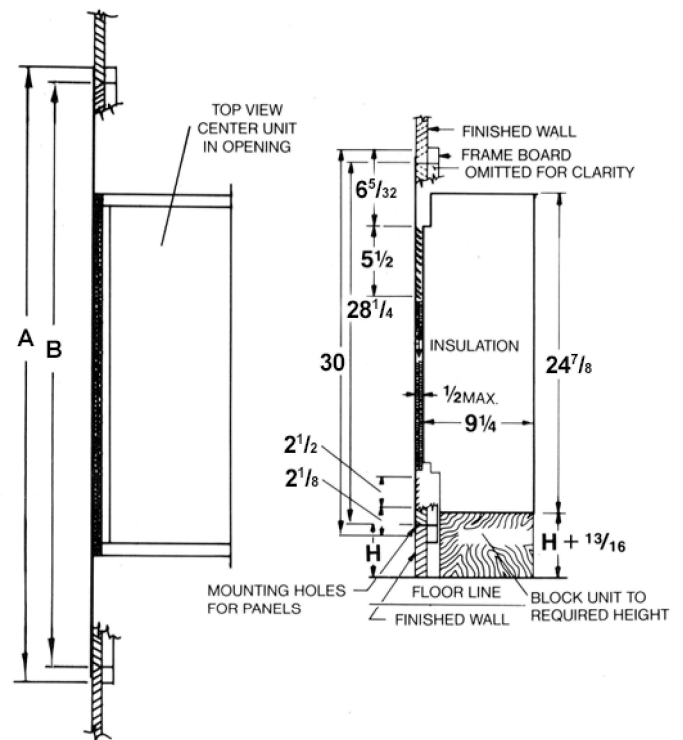
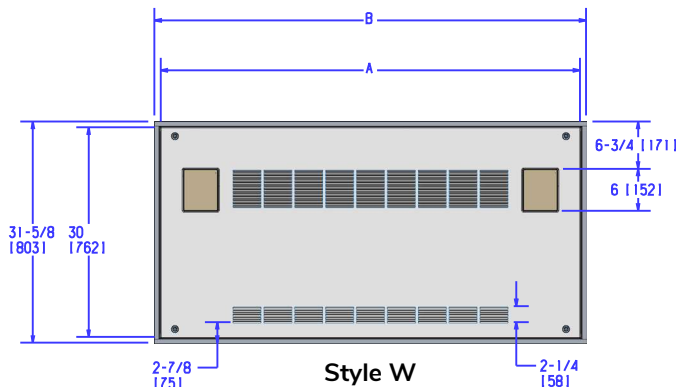

Figure 23. Style W Framed Wall Panel

Dimensions provided in inches (mm)



### SECTION ONE — Installation, Cont'd.

Figure 26. Style Z Framed Wall Panel Install Diagram

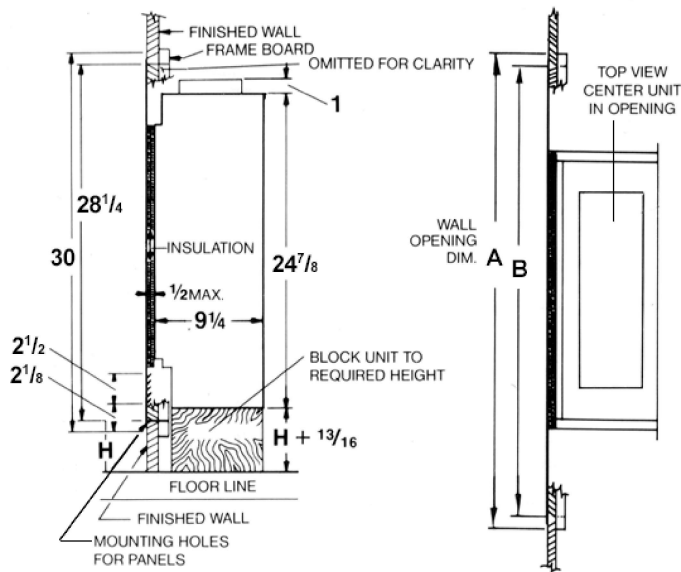
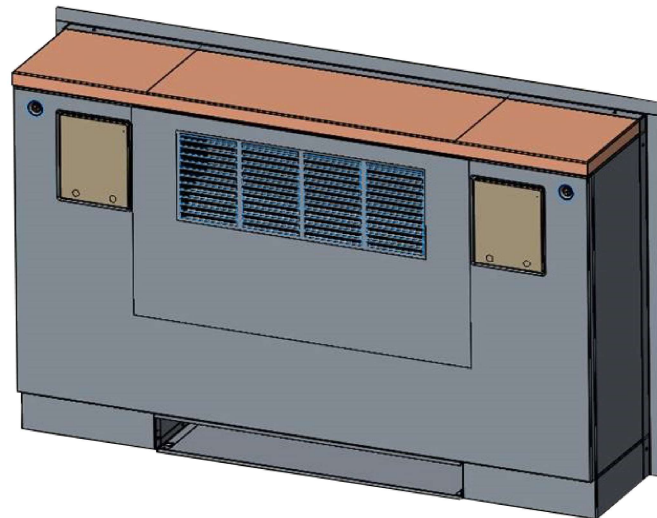

Figure 27. Trim Kit Around Floor Mount Unit



#### Optional Trim Kit Installation

An optional trim kit can be applied to partially recess the FXA, FSA units in the wall. The trim kit can also be applied to cover rough opening to eliminate the need for finish work such as carpentry, drywall, painting, etc.

Reference unit submittal drawings for unit sizes. Trim kits have 1" flanges.

There are 3 mounting brackets (two sides, one top) provided in the trim kit for floor mount units. There are 4 mounting brackets (two sides, top, bottom) in the trim kit for wall mount units. There are no mounting holes provided on the unit so the brackets can be positioned at whatever depths is required for recess. Use self tapping screws to secure the brackets to the unit.

#### Rear Cabinet Extension Installation (Vertical Floor)

NOTE – Rear cabinet extension instructions also applicable for obsolete F\*C and F\*Y floor families.

An option to install a rear cabinet extension is available on FXA and FSA vertical floor mounted units. The cabinet extensions ship loose and are field installed.

The extension pieces should be assembled to align with the dimensions of the back of the floor unit, utilizing field-provided screws (Reference Figure 27a).

Figure 27a. Rear Cabinet Extension Assembly

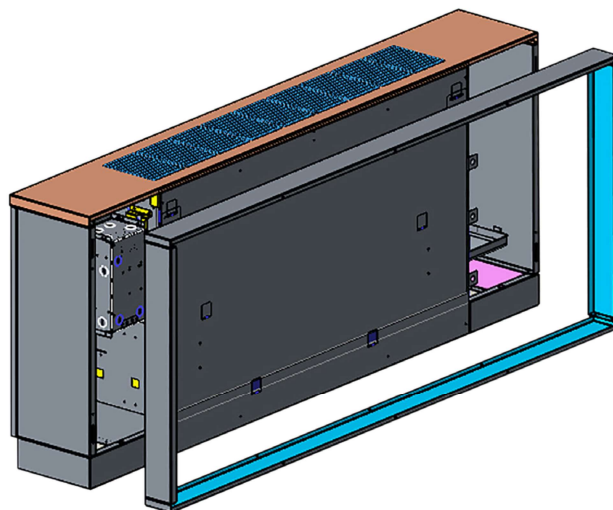

### SECTION ONE — Installation, Cont'd.

Once the extension has been assembled, survey the back of the floor unit to ensure there is no loose debris or obstructions. Secure the rear extension, flush to the back of the floor unit, utilizing the pre-cut screw holes on the flange of the rear extension and field-provided screws (Reference Figure 27b).

Figure 27b. Rear Cabinet Extension Installation

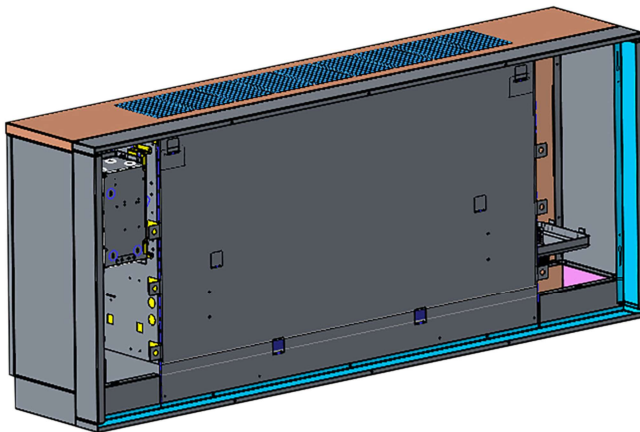

#### Cooling/Heating Connections

After mounting the unit, it is then ready for the various service connections such as water, drain and electrical. At this time, it should be verified that the proper types of services are actually provided to the unit. On those units requiring chilled water and/or hot water, the proper line size and water temperature should be available to the unit. In the case of refrigerant cooling, the proper line size and refrigerant type should be available to the unit. On units with steam-heating coils, the proper line sizing and routing should be verified, and the maximum steam pressure applied to the unit should never exceed 10 psig (69 KPa). The drain piping and steam trap should be sized and routed to allow for proper condensate flow.



**CAUTION: Toxic residues and loose particles resulting from manufacturing and field piping techniques such as joint compounds, soldering flux, and metal shavings may be present in the unit and the piping system. Special consideration must be given to system cleanliness when connecting to solar, domestic or potable water systems.**

Submittals and product literature detailing unit operation, controls, and connections should be thoroughly reviewed BEFORE beginning the connection of the various cooling and/or heating mediums to the unit.

#### 1. Horizontal Ceiling Drain Pan Removal

CXB, CBY, CHY and CPY Horizontal models come with a removable drain pan. The drain pan should be removed before installing or servicing the valve package. An extended drill bit may be necessary to access the screws to remove the drain pan.

**NOTE: Exact location of screws to remove drain pan may vary based on horizontal model.**

#### 2. Condensate Drain Pan

The drain should always be connected and piped to an acceptable disposal point. For proper moisture carry-off, the drain piping should be sloped away from the unit at least 1/8 inch per foot. A drain trap may be required by local codes and it is strongly recommended for odor containment. When furnished, the optional 5/8-inch secondary or “tell-tale” connection must be piped to some location where an indication of drain flow restriction may be readily observed. Units furnished with a “tell-tale” connection should be sloped very slightly towards the drain outlets. The differential height of the trap inlet to outlet must be at least one inch greater than the total static pressure on the unit. The height from the drain outlet to the bottom of the trap must not be less than the total static pressure. The condensate drain hose should be secured with a clamp after installing.

#### 3. Auxiliary Drain Pan

NOTE – Auxiliary drain pan instructions also applicable for obsolete F\*C and F\*Y floor families.

On some units (F\*A, LH\*, LX\*, ST\*), an auxiliary drain pan is included to collect condensate from the primary drain pan and then to direct this condensate to a drain by way of a sloped pipe, recommended to include a p-trap or other air-trap device. The auxiliary drain pan is also to collect any condensate coming from a valve package or other piping connected to the coil.



### SECTION ONE — Installation, Cont'd.

Included with each unit is a feature for connecting the auxiliary drain pan, found on the lower section of the inner-case leg, a part of the metal casing supporting the coil and fan, and to the same side as where piping connects to the coil and where any valve package is located.

The auxiliary drain pan is shipped loose from the factory and must be installed directly below the drain tube leading from the primary drain pan and a condensate overflow switch where applicable.

The auxiliary drain pan is situated to the inner-case leg by way of either supporting tabs extending from the case leg or by way of slots in the case leg. The drain pipe or a drain trap is then connected to the stub-out off the bottom side of this pan. Finally, confirm that the pan is secure and positively situated so that condensate coming from the primary drain pan is collected.

#### 4. Valve Package Install (when applicable)

**NOTE: Always protect chilled and hot water valve bodies, strainers, ball valves, and other flow control related devices from heat caused by soldering or brazing processes by wrapping these devices in cold or damp rags.**

**NOTE: Zone valves recommended to prevent excessive condensate (from running wild coil).**

All accessory valve packages should be installed as required, and all service valves should be checked for proper operation.

If coil and valve package connections are to be made with a “sweat” or solder joint, care should be taken to assure that no components in the valve package are subjected to a high temperature which may damage seals or other materials. Many two-position electric control valves, depending on valve operation, are provided with a manual opening lever. This lever should be placed in the “open” position during all soldering or brazing operations.

Ground-Joint seal preparation for copper unions (recommended by manufacturer):

1. Make sure the ground joint area is free of nicks and scratches.
2. Spray the ground-joint area with silicone spray for beeswax to enhance seating.
3. Recommended torques for ground joint seal:  
 $\frac{1}{2}$ " (12.7 mm) (nominal) unions – 35 ft./lbs. (23, 519 mm/kg) (minimum)  
 $\frac{3}{4}$ " (19 mm) (nominal) unions – 60 ft./lbs. (40,318 mm/kg) (minimum)
4. Make sure alignment of line does not put lateral stress on the ground-joint seal.
5. Make sure that excess solder droplets do not reach the ground-joint area.

If the valve package connection at the coil is made with a union, the coil side of the union must be prevented from twisting (“backed up”) during tightening to prevent damage to the coil tubing. Over-tightening must be avoided to prevent distorting (“egg shaping”) the union seal surface and destroying the union.

The supply and return connections are marked on the coil stub-outs and the valve package, with an “S” meaning supply or inlet and “R” meaning return or outlet indicating flow direction to and from the coil. Blue letters mark the chilled water connections and red letters mark the hot water or steam connections.

In the case of field-installed valves and piping, the chilled water valve cluster (or expansion valve on DX units) should be installed in such a way that any dripping or sweating is contained in the drain pan or other device such as an optional extended drain pan or factory drip lip. Factory drip lips are field installed and may be packaged separately from the unit. Factory supplied cooling coil valve packages will be arranged to locate as much of the package as possible over a standard drip lip.

### SECTION ONE — Installation, Cont'd.

1. For CXB and CBY units, factory provides tube extensions to penetrate the rear of the fan coil cabinet. Chilled and hot extension tubes must be properly insulated.  
  
Label each tube extension for purpose, i.e: "CS" Cooling Supply, etc. Solder tube extensions to the valve package.
2. Remove valve actuators temporarily during valve installation. Protect unit wiring from damage.
3. **Install valve packages and connect to the coil in sequence, first heating, then cooling.**
4. Torque unions tight using backup wrench to prevent damage to coil tubes. Align exiting tubes to the center of the pipe openings.
5. If desired, apply split bushings or grommets (provided by others) to the pipes for mechanical support and protection. Do not allow copper tube to contact steel cabinet.
6. Now is a good time to leak test the unions and fittings, using air pressure and soap. The coil air vent(s) may be used for this purpose.

Figure 28. General valve package assembly. CXB unit shown.

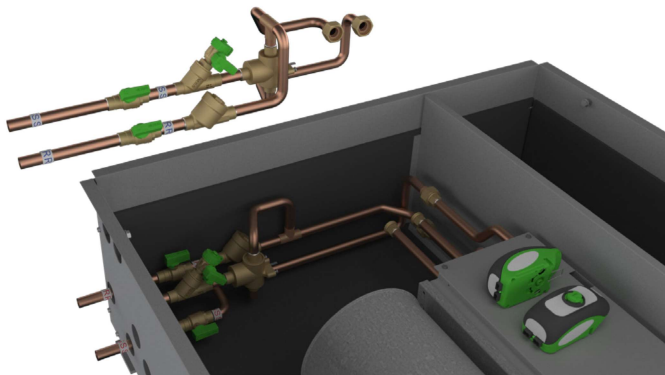

If none of the above factory accessories have been provided with the units, a drip lip (available from the factory) may still be required to direct piping condensate into the unit drain pan.

After the connections are completed, the system should then be tested for leaks. Since some components are not designed to hold pressure with a gas, hydronic systems should be tested with water. Pressure testing should be completed prior to sheet rocking or painting.



**CAUTION: All water coils must be protected from freezing after initial filling with water. Even if the system is drained, unit coils may still hold enough water to cause damage when exposed to temperatures below freezing.**

Refrigerant systems should be tested with dry nitrogen rather than air to prevent the introduction of moisture into the system. In the event that leaking or defective components are discovered, the Sales Representative must be notified BEFORE any repairs are attempted. All leaks should be repaired before proceeding with the installation.

After system integrity has been established, insulate the piping in accordance with the project specifications. This is the responsibility of the installing or insulation contractor. All chilled water piping and valves or refrigerant suction piping not located over drain pans or drip lips must be insulated to prevent damage from sweating. This includes factory and field piping inside the unit cabinet.

#### Electrical Connections

The electrical service to the unit should be compared to the unit nameplate to verify compatibility. The routing and sizing of all piping, and the type and sizing of all wiring and other electrical components such as circuit breakers, disconnect switches, etc. should be determined by the individual job requirements. Verify the electrical conductor size is suitable for the distance to the equipment connection and will support the equipment electrical load. All installations should be made in compliance with all governing codes and ordinances. Compliance with all codes is the responsibility of the installing contractor.

### SECTION ONE — Installation, Cont'd.

The unit serial plate lists the unit electrical characteristics such as the required supply voltage, fan and heater amperage and required circuit ampacities. The unit wiring diagram shows all unit and field wiring. Since each project is different and each unit on a project may be different, the installer must be familiar with the wiring diagram and serial plate on the unit BEFORE beginning any wiring.

All components furnished for field installation by either the factory or the controls contractor should be located and checked for proper function and compatibility. All internal components should be checked for shipping damage, and any loose connections should be tightened to minimize problems during start-up.

Any devices such as fan switches or thermostats that have been furnished from the factory for field installation must be wired in strict accordance with the wiring diagram that appears on the unit. Failure to do so could result in personal injury or damage to components and will void all manufacturer's warranties.

The fan motor(s) should never be controlled by any wiring or device other than the 3-speed switch or thermostat/switch combination without factory authorization. Fan motor(s) may be temporarily wired for use during construction only with prior factory approval in strict accordance with the instructions issued at that time.

Units with optional factory-furnished and installed aquastats may be shipped with the aquastats mounted on a coil stub-out. Remove the aquastat before installation of a valve package. Consult the factory piping diagram in the approved submittals for proper location when reinstalling the aquastats. If the valve package is field-furnished, the aquastat must be installed in a location where it will sense the water temperature regardless of control valve position. A bleed bypass may be required to guarantee proper aquastat operation.

All field wiring should be done in accordance with governing codes and ordinances. Any modification of the unit wiring without factory authorization will void all of the factory warranties, and will nullify any agency listings.

The manufacturer assumes no responsibility for any damages and/or injuries resulting from improper field installation and/or wiring.

1. After planning for and bringing incoming power to the unit, locate the control box and cover plate (incoming electrical power wiring compartment).

Figure 29. Control box with cover plate

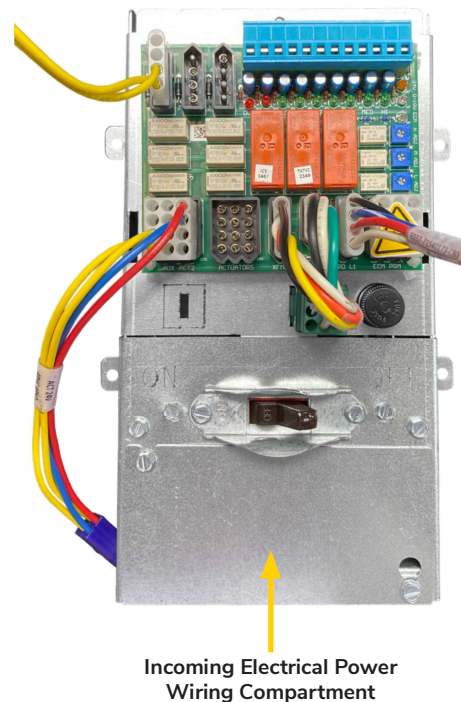

2. Determine appropriate knock out to feed incoming power wiring into box.
3. Loosen screws to rotate cover plate to access wiring.



### SECTION ONE — Installation, Cont'd.

Figure 30. Loosened cover plate

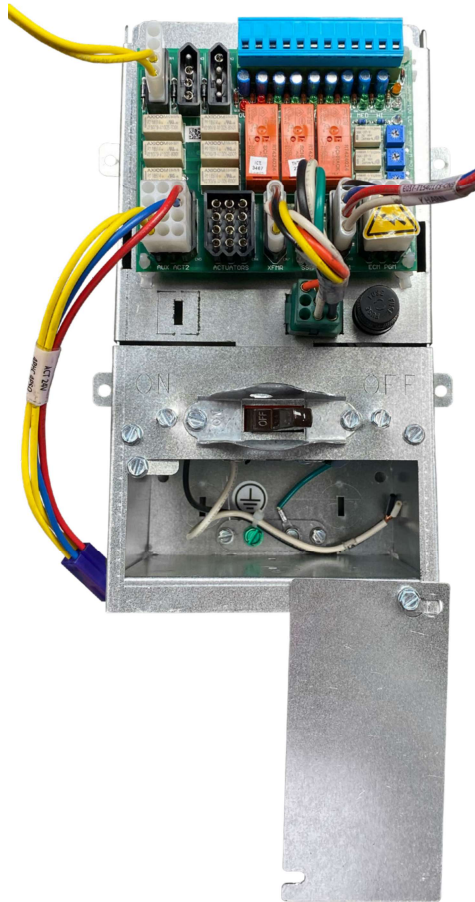

Figure 31. Unit-mounted control box access

\*NOTE – Image depicts control box mounted in CBY unit

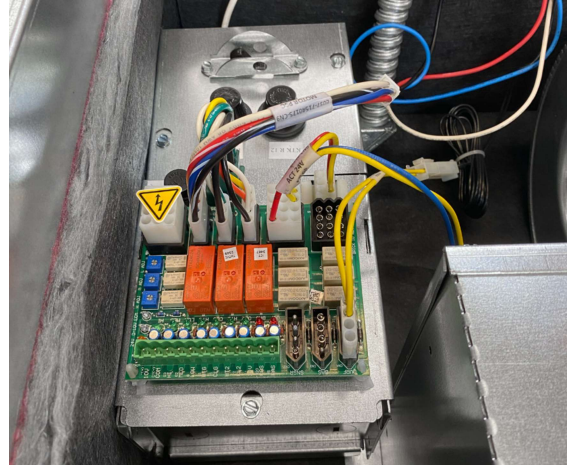
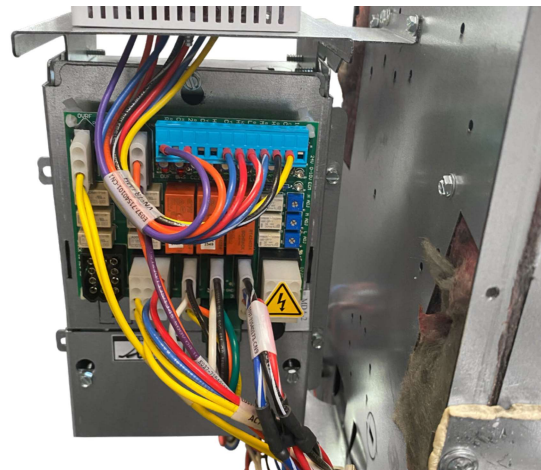

Figure 32. External unit-mount control box access

\*NOTE – Image depicts control box mounted on LHA unit



4. Secure incoming power wiring with proper service entrance connector and/or appropriate strain relief. Use wire nuts connections that meet wire gauge requirements.
5. Replace cover plate and secure screws.

### SECTION ONE — Installation, Cont'd.

**Figure 33. Thermostat unit-mount**

\*NOTE – Image below depicts control box with Venture Wi-Fi Thermostat mounted on LHA unit



#### Ductwork Connections

All ductwork and/or supply and return grilles should be installed in accordance with the project plans and specifications. If not included on the unit or furnished from the factory, supply and return grilles should be provided as recommended in the product catalog.

For units with no return-air ductwork, check local code requirements for possible application restrictions. All units must be installed in areas that are non-combustible.

Some models are designed to be connected to ductwork with a MINIMUM amount of external static pressure. These units may be damaged by operation without the proper ductwork connected. Consult the approved submittals and the product catalog for unit external static pressure limitations.

Units provided with outside air for ventilation should have some form of low-temperature protection to prevent coil freeze-up. This protection may be any of several methods such as a low-temperature thermostat to close the outside air damper or a preheat coil to temper the outside air before it reaches the unit.

It should be noted that none of these methods will adequately protect a coil in the event of power failure. The safest method of freeze protection is to use glycol in the proper percent solution for the coldest expected air temperature.

#### 1. Horizontal plenum-type

CPY units may be shipped with a bottom return-air inlet. These units may be converted to rear return by removing the bottom inlet filter retainer clips and filter, then removing the plenum rear panel. The rear panel must then be moved to the bottom of the unit and reversed so that the top edge (when rear mounted) is toward the supply end of the unit and reinstalled on the bottom of the plenum. The panel should be positioned towards the drain pan to expose the one-inch wide filter slot for unit-mounted filters. The panel should be positioned against the rear bottom brace completely covering the bottom of the plenum on units with remote filters.

#### 2. Hi-Performance plenum-type

HPY units may be shipped with a bottom return-air inlet. These units may be converted to rear return by simply exchanging the bottom and rear plenum panels.

Flexible duct connections should be used on all air handling equipment to minimize vibration transmissions. All ductwork and insulation should be installed to allow proper access to all components for service and repair such as filters, motor/blower assemblies, etc.

The manufacturer assumes no responsibility for undesirable system operation due to improper design, equipment or component selection, and/or installation of base unit, ductwork, grilles, and other related components.

### SECTION ONE — Installation, Cont'd.

#### Final Preparations

1. Turn off power to the unit (open unit electrical disconnect) and install lockout tags on all power supplies to unit.
2. Install thermostats and perform any other final wiring as applicable. Ensure all electrical connections are tight.
3. Perform a final visual inspection. All equipment, plenums, ductwork, and piping should be inspected to verify that all systems are complete and properly installed and mounted, and that no debris or foreign articles such as paper or drink cans are left in the units or other areas. Clean dirt, dust, and other construction debris from unit interior. Be sure to check fan wheel and housing and clean, if necessary.
4. Rotate fan wheel by hand to be sure it is free and does not rub housing. Check that wing nuts securing fan assembly to fan deck are tight. Adjust if necessary.
5. Install filter in frame at front of coil. If field-supplied filters are used, be sure size is as specified in Table 2.
6. Ensure all panels and filters are installed before checking fan operation. Turn on power to the unit.
7. Check the fan and motor operation.
8. Verify drain line is properly and securely positioned and that the line is clear. Pour water into drain to check operation.

### SECTION TWO — Start-Up

#### General Start Up

Before beginning any start-up operation, the start-up personnel should familiarize themselves with the unit, options and accessories, and control sequence to understand the proper system operation. All personnel should have a good working knowledge of general start-up procedures and have the appropriate start-up and balancing guides available for consultation.

The building must be completely finished including doors, windows, and insulation. All internal walls and doors should be in place and in the normal position. In some cases the interior decorations and furniture may influence overall system performance. The entire building should be as complete as possible before beginning any system balancing.

The Building breaker will be used as the disconnect switch. An additional service switch may be installed on the unit.

The initial step in any start-up operation should be a final visual inspection. All equipment, plenums, duct-work, and piping should be inspected to verify that all systems are complete and properly installed and mounted, and that no debris or foreign articles such as paper or drink cans are left in the units or other areas.

Each unit should be checked for:

1. free blower wheel operation
2. loose wires
3. loose or missing access panels or doors
4. clean filter of the proper size and type

Except as required during start-up and balancing operations, no fan coil units should be operated without all the proper ductwork attached, supply and return grilles in place, and all access doors and panels in place and secure. Failure to do so could result in damage to the equipment or building and furnishings, and/or void all manufacturer's warranties.

Maximum operating altitude for units is 13,400 ft. (4 km). All units are IPXO rated.

#### Cooling/Heating System

Prior to the water system start-up and balancing, the chilled/hot water systems should be flushed to clean out dirt and debris which may have collected in the piping during construction. During this procedure, all unit service valves must be in the closed position. This prevents foreign matter from entering the unit and clogging the valves and metering devices. Strainers should be installed in the piping mains to prevent this material from entering the units during normal operation.

During system filling, air venting from the unit is accomplished by the use of the standard, manual air vent fitting, or the optional, automatic air vent fitting installed on the coil. Manual air vents are basically Schrader valves. To vent the air from the coil, depress the valve until the air has vented the coil. When water begins to escape through the valve, release the valve. Automatic air vents may be unscrewed one turn counterclockwise to speed initial venting, but should be screwed in for automatic venting after start-up operations.



**CAUTION! The air vent provided on the unit is not intended to replace the main system air vents and may not release air trapped in other parts of the system. Inspect the entire system for potential air traps and vent those areas as required, independently. In addition, some systems may require repeated venting over a period of time to properly eliminate air from the system.**

## SECTION TWO — Start-Up, Cont'd.

### Direct Expansion (DX) Systems

**Note:** Operation of DX equipped fan coils at any fan speed other than high fan speed is not approved and will void the manufacturer's limited warranty.

-  Do not operate fan coils with a DX evaporator coil plus contiguous hydronic coil without use of a suitable glycol solution that is approved for use by the manufacturer. Failure to follow this instruction will void the manufacturer's limited warranty.
- Should the evaporator freeze due to inadequate airflow for any reason, damage may occur to adjacent water or steam coil tubing. This type of issue is due to product misapplication and voids the manufacturer's limited warranty.

### Air System Balancing

All ductwork must be complete and connected. All grilles, filters, and access doors and panels must be properly installed to establish actual system operating conditions **BEFORE** beginning air balancing operations.

Each individual unit and the attached ductwork is a unique system with its own operating characteristics. For this reason, air balancing is normally done by balance specialists who are familiar with all procedures required to properly establish air distribution and fan-system operating conditions. These procedures should not be attempted by unqualified personnel.

Exposed units without ductwork do not require air balancing other than selecting the desired fan speed.

After proper system operation is established, the actual unit air delivery and the actual fan motor amperage draw for each unit should be recorded in a convenient place for future reference.

### Maximum External Static Pressures

Table 8. Hi-Performance H\*Y, VEY

External Static Pressure	
Max @ High Speed	0.70
Max @ Med Speed	0.61
Max @ Low Speed	0.20

Table 9. Ceiling C\*Y

External Static Pressure	
Max @ High Speed	0.50
Max @ Med Speed	0.40
Max @ Low Speed	0.20

Table 10. Floor F\*A

External Static Pressure	
Max @ High Speed	0.40
Max @ Med Speed	0.29
Max @ Low Speed	0.12

Table 11. Floor Lowboy L\*\*

External Static Pressure	
Max @ High Speed	0.50
Max @ Med Speed	0.42
Max @ Low Speed	0.25

### SECTION TWO — Start-Up, Cont'd.

#### Water Treatment

Proper water treatment is a specialized industry. IEC recommends consulting an expert in this field to analyze the water for compliance with the water quality parameters listed below, and to specify the appropriate water treatment regimen. The expert may recommend typical additives such as rust inhibitors, scaling preventative, antimicrobial growth agents, or algae preventatives. Anti-freeze solutions may also be used to lower the freezing point.

IEC water coil tubes and headers are constructed of pure copper. Multiple brass alloys may be present in the valve package, depending on unit configuration. It is the user's responsibility to ensure the tube and piping materials furnished by IEC, are compatible with the treated water.

**Failure to provide proper water quality will void the fan coil unit's warranty.**

Water Containing	Required Concentration
Sulphate	Less than 200 ppm
pH	7.0 – 8.5
Chlorides	Less than 200 ppm
Nitrate	Less than 100 ppm
Iron	Less than 4.5 mg/l
Ammonia	Less than 2.0 mg/l
Manganese	Less than 0.1 mg/l
Dissolved Solids	Less than 1000 mg/l
CaCO3 Hardness	300 - 500 ppm
CaCO3 Alkalinity	300 - 500 ppm
Particulate Quantity	Less than 10 ppm
Particulate Size	800 micron max

Maximum Water Operating Temperature: 190° (87°C)  
 Maximum Allowable Water Pressure: 500 PSIG (3447 kpa)

#### Water System Balancing

A complete knowledge of the hydronic system, along with its components and controls, is essential to proper water system balancing. This procedure should not be attempted by unqualified personnel. The system must be complete, and all components must be in operating condition **BEFORE** beginning water system balancing operations.

Each hydronic system has different operating characteristics depending on the devices and controls used in the system. The actual balancing technique may vary from one system to another.

After the proper system operation is established, the appropriate system operating conditions such as various water temperatures and flow rates should be recorded in a convenient place for future reference.

Before, and during water system balancing, conditions may exist due to incorrect system pressures which may result in noticeable water noise or undesired valve operation. After the entire system is balanced, these conditions will not exist on properly designed systems.



## **SECTION THREE — Controls Operation**

### **SECTION THREE – Controls Operation**

#### **Board Components and Specifications**

Before proper control operation can be verified, all other systems must be operating properly. The correct water and air temperatures must be present for the control function being tested. Some controls and features are designed to not operate under certain conditions. For example, on a 2-pipe cooling/heating system with auxiliary electric heat, the electric heater cannot be energized with hot water in the system. A wide range of controls, electrical options and accessories may be used with the equipment covered in this manual. Consult the approved unit submittals, order acknowledgments, and other literature for detailed information regarding each individual unit and its controls. Since controls and features may vary from one unit to another, care should be taken to identify the controls used on each unit and their proper control sequence. Information provided by component manufacturers regarding installation, operation, and maintenance of their individual controls is available upon request.

### SECTION THREE – Controls Operation, Cont'd.

#### 85 Control Board (E025-71481108)

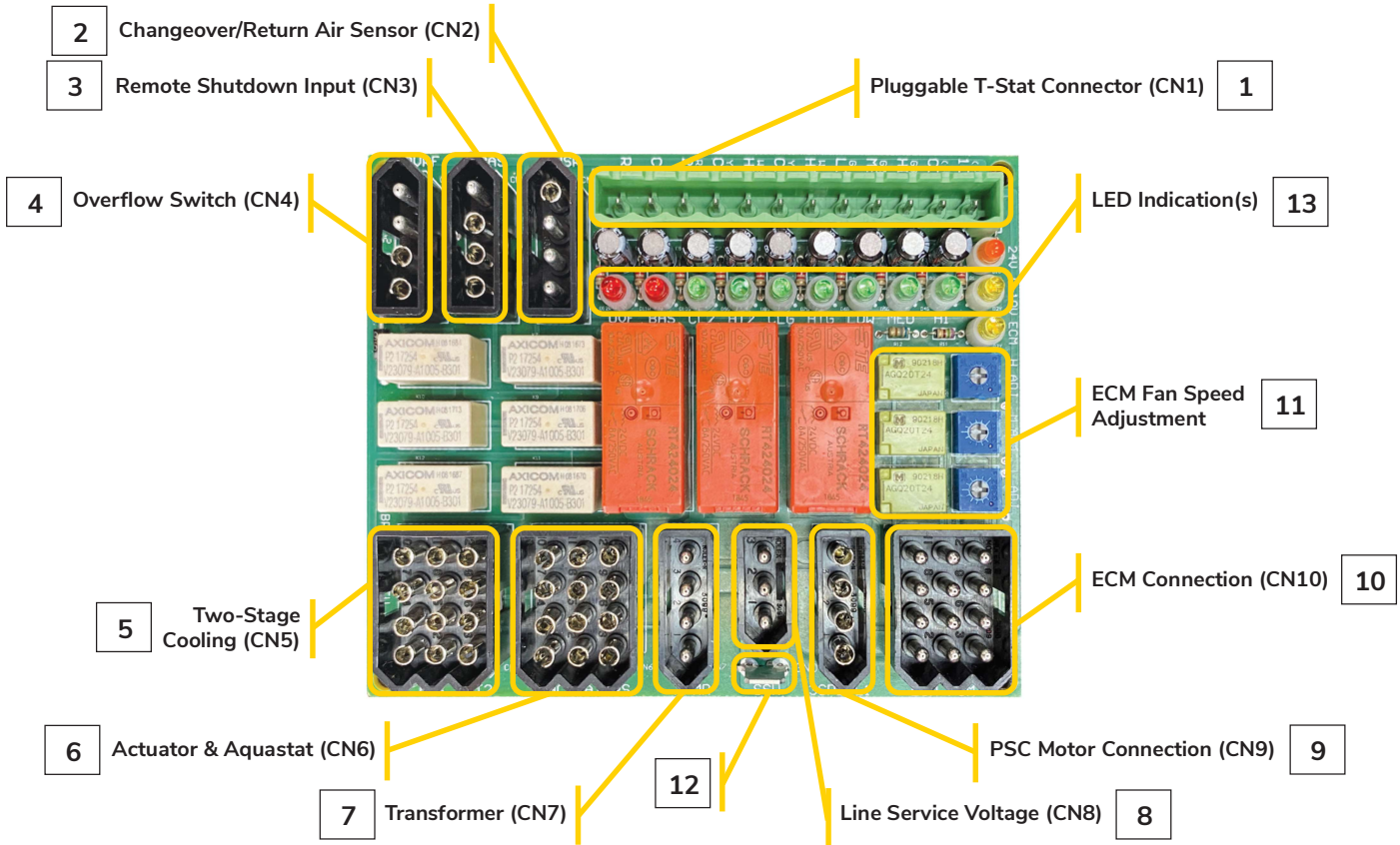

1	CN1 – 24V Customer Input (Thermostat)
2	CN2 – Changeover/Return Air Sensor
3	CN3 – Remote Shutdown Input
4	CN4 – Condensate Overflow Switch
5	CN5 – Two Stage Cooling
6	CN6 – Actuator 7 Aquastat
7	CN7 – Transformer
8	CN8 – Line Service Voltage
9	CN9 – PSC Motor Connection
10	CN10 – ECM Connection
11	ECM Fan Speed Adjustment
12	Ground Connection
13	LED Diagnostics (for Multimeter Diagnostics)



### SECTION THREE – Controls Operation, Cont'd.

#### Board Function and Diagnostics

##### 1. CN1 – 24V Customer Input (Thermostat)

Use proper wire gauge and insulation type based on application and local code requirements.

For detailed IEC 24V thermostat control wiring diagrams, reference thermostat IOMs.

##### For Factory Installed IEC 24V Thermostat\*

\* Does not apply to proportional or Line voltage thermostat controls. The diagram below represents a factory installed IEC 24V thermostat.

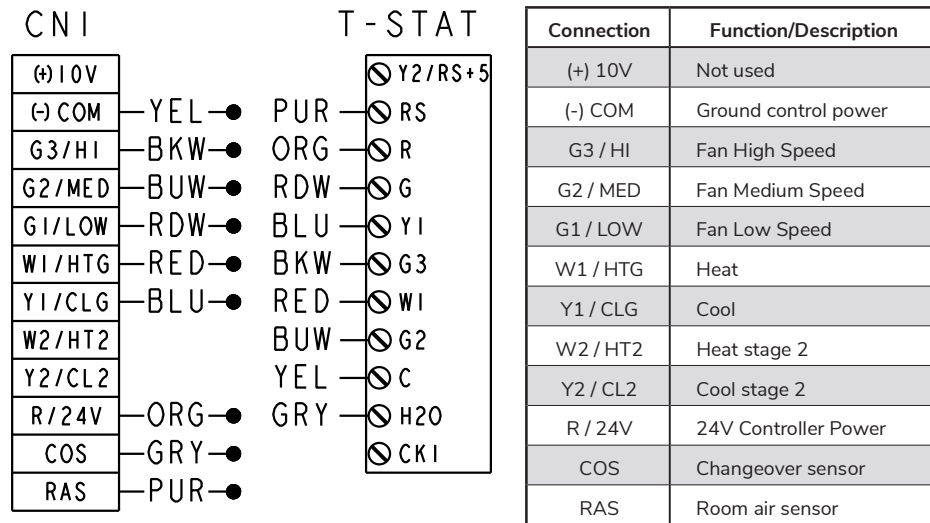
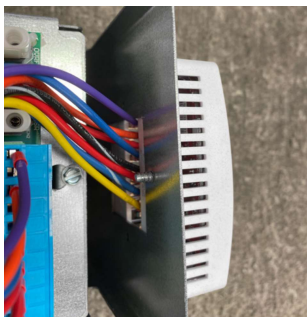

Figure 34. Thermostat wire harness connection



Figure 35. Mounted thermostat connection

\*NOTE – Image depicts an IEC unit-mounted Venture Wi-Fi Thermostat.



### SECTION THREE – Controls Operation, Cont'd.

#### For Thermostat Control By Others or Remote Mounted Thermostat

**Figure 36.** Unplug blue connector from control board. Make appropriate thermostat wiring connections and plug connector back to control board.

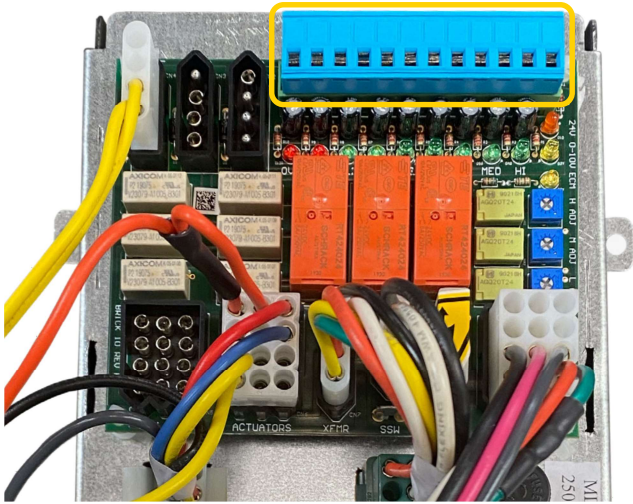

#### CN1 - PLUG

(+) 10V
(-) COM
G3/HI
G2/MED
G1/LOW
W1/HTG
Y1/CLG
W2/HT2
Y2/CL2
R/24V
COS
RAS

Connection	Function/Description
(+) 10V	Apply 0-10V signal for proportional fan speed control (ECM only)
(-) COM	Ground control power
G3 / HI	Apply 24V signal for High Speed Control
G2 / MED	Apply 24V signal for Medium Speed control
G1 / LOW	Apply 24V signal for Low Speed Control
W1 / HTG	Apply 24V for Stage 1 heat
Y1 / CLG	Apply 24V for Stage 1 cool
W2 / HT2	Apply 24V for Stage 2 heat
Y2 / CL2	Apply 24V for Stage 2 cool
R / 24V	24V Controller Power
COS	Changeover sensor
RAS	Room air sensor

#### 2. CN2 – Changeover/Return Air Sensor

- Power connector for 24V or Common-powered sensors
  - 24V powered sensors
    - Applicable for IEC-supplied air sensor for Wi-Fi (E055-71520330), Programmable (E055-71520317), Non-programmable (E055-71520316) 24V IEC thermostats
  - Common-powered sensors
    - Applicable for thermostats by others
- Sensor/switch
  - 10k thermistor
  - Bimetal switch

#### 3. CN3 – Remote Shutdown Input

- Provides dry contact for signal to BAS system – I/O
  - Dry Normally Open
  - Wet Normally Open
  - Discrete Coil
- When contact activated
  - Motor OFF
  - Actuator OFF
  - Electric Heat OFF
  - Power to controller remains ON
- BAS LED indication when BAS relay circuit activated

## **SECTION THREE – Controls Operation, Cont'd.**

### **4. CN4 – Condensate Overflow Switch**

- Low voltage condensate switch shuts down the unit when the water level in the drain pan reaches an unsafe level.
  - a. Switch is normally closed and opens on an increase in water level.
- When contact activated, then
  - a. Motor OFF
  - b. Valve Actuator OFF
  - c. Electric Heat OFF
  - d. Power to controller remains ON
- OVF LED indication when condensate switch activated

### **5. CN5 – 2nd Stage Cooling/Heating**

- Available with two stage coil for part load
  - a. Available with IEC Venture Wi-Fi Thermostat (E055-71520330). Contact factory for application.
- 24V On/Off, 24V Floating, 0-10V Proportional control
- CL2 or HT2 LED indication when either 2<sup>nd</sup> stage cooling or heating activated

### **6. CN6 – 1st Stage Cooling/Heating**

- 24V On/Off, 24V Floating, 0-10V Proportional control, Line voltage
- SureFlow control available. Contact factory for applications
- CLG or HTG LED indication when either 1<sup>st</sup> stage cooling or heating activated

### **7. CN7 – Class II Transformer**

- 40VA, 75VA option
- 24V LED activated when powered

### **8. CN8 – Incoming Power**

### **9. CN9 – PSC Motor**

- 3 speed application
- Either LOW/MED/HI activated when a speed is selected

### **10. CN10 – EC Motor**

- 3 speed application
- Solid State switching
- Either LOW/MED/HI activated when a speed is selected
- ECM LED indicates speed control is powered
- 0-10V LED intensity indicates increasing speed

### **11. ECM Fan Speed Adjustment**

If the unit is equipped with an ECM blower, additional steps may be required during the air balancing process. Review project submittals or order acknowledgment to determine which ECM control scheme the unit has. Alternatively, match the control board to the illustrations.



**CAUTION!** Both of the procedures described below require the control box to be powered while adjustments are made. Line voltage components are concealed behind a secondary cover. However, installer should still take all reasonable precautions.

### SECTION THREE – Controls Operation, Cont'd.

#### 11. ECM Fan Speed Adjustment, cont'd.

Figure 37. 3-Speed, Potentiometer Adjustment (ECM Only)  
(E025-71481108)

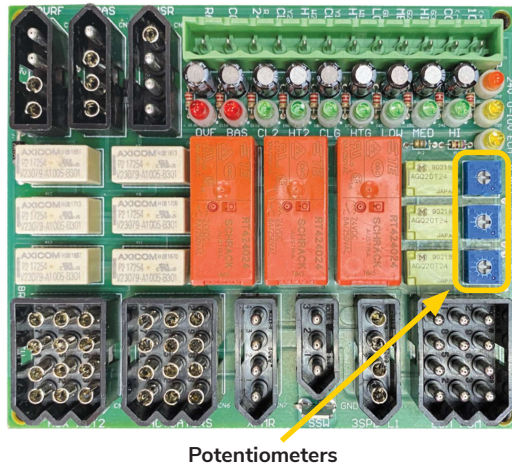
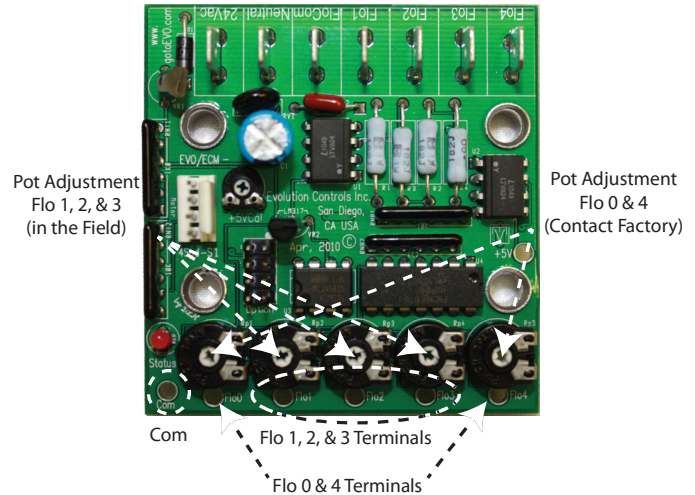

Figure 38. 4-Speed, Solid State with Potentiometer  
(E025-71521503)



**Note:** The unit has been factory configured to produce PSC equivalent airflow on high speed, with medium and low speed set at 80% and 60% of high, respectively. If these settings are acceptable, then no further configuring is required.

If alternative airflows are desired, use board mounted pots to adjust the airflow associated with each input. To reset to initial factory settings, reference the voltages found on the sticker next to the pots.

Each output can be adjusted from 0 to 100% of the motor's factory programmed operating range. Use voltmeter and airflow chart (on control box cover) to set values.

Adjusting the potentiometers requires the use of a Multi-meter capable of measuring 0~5 vdc.

1. Only trained and qualified individuals should attempt to adjust or service components on any electrical component. Failure to follow safety rules could result in electrical shock or hazard.
2. 24 VAC power must be supplied to ECM board to make adjustments.
3. Set the electrical multimeter to Volts Direct Current (Vdc) on the 0~5 or 0~20 Vdc scale.
4. Attach black (negative) lead of meter to the "Com" terminal to the left of the potentiometers and below the Status light.
5. Attach the red (positive) lead of the meter to the terminal below the Potentiometer needing adjustment.
  - a. High Speed: Using a small screwdriver, turn the H ADJ potentiometer (CW for increasing speed, CCW for decreasing speed).
  - b. Medium Speed: Using a small screwdriver, turn the M ADJ potentiometer (CW for increasing speed, CCW for decreasing speed).
  - c. Low Speed: Using a small screwdriver, turn the L ADJ potentiometer (CS for increasing speed, CCW for decreasing speed).

## **SECTION THREE – Controls Operation, Cont'd.**

### **11. ECM Fan Speed Adjustment, cont'd.**

#### **Variable Airflow for 0-10 VDC**

If a factory provided thermostat or DDC controller is utilized, then the unit is already correctly configured.

IEC recommends using the specified thermostat or DDC controller to commission the unit whenever possible. However, the blower can be started and operated without the thermostat. Consult factory for further instruction.

#### **ECM Variable Airflow for 0-10 VDC**

No control board is required and no field adjustments are possible. Motor uses 0-10VDC signal directly. See control box label. Fan enable at 1.5VDC.

### **12. Ground Tab Connection**

- For multimeter diagnostics

### SECTION THREE – Controls Operation, Cont'd.

#### 13. LED Function and Outcomes (Sequence of Operations)

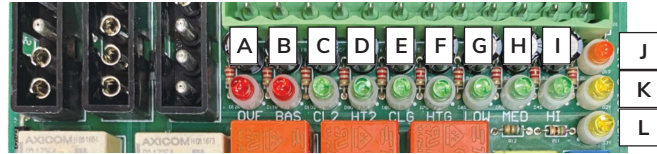

Item	Description	Outcome
A	Condensate Overflow Switch (OVF) Condensate switch is tripped by increasing water level in the drain pan	<ul style="list-style-type: none"> <li>OVF LED Shows Red</li> <li>Motor OFF</li> <li>Actuator OFF</li> <li>Electric Heat Off</li> <li>Power to controller remains ON</li> </ul>
B	Remote Shutdown Input (BAS) 24VAC externally applied to BAS CN3 or the internally-powered BAS CN3 loop is closed	<ul style="list-style-type: none"> <li>BAS LED shows RED</li> <li>Motor OFF</li> <li>Actuator OFF</li> <li>Electric Heat Off</li> <li>Power to controller remains ON</li> </ul>
C	Cooling 2 <sup>nd</sup> Stage (24VAC and 0-10VDC) (CL2) 24VAC signal applied to CL2 of CN1. 2 <sup>nd</sup> stage cooling relay (CL2) will actuate and supply 24VAC to Pin 9 of connector CN5. When 0-10VDC is applied to CL2, control signal will passively be present at Pin 7 of the CN5 connector.	<ul style="list-style-type: none"> <li>CL2 LED shows GREEN</li> <li>Signal for 2<sup>nd</sup> stage cooling valve present</li> </ul>
D	Heating 2 <sup>nd</sup> Stage (24VAC and 0-10VDC) (HT2) 24VAC signal applied to HT2 of CN1. 2 <sup>nd</sup> stage heating relay (HT2) will actuate and supply 24VAC to Pin 9 of connector CN5. When 0-10VDC is applied to HT2, control signal will passively be present at Pin 7 of the CN5 connector.	<ul style="list-style-type: none"> <li>HT2 LED shows GREEN</li> <li>Signal for 2<sup>nd</sup> stage heating valve present</li> </ul>
E	Cooling 1 <sup>st</sup> Stage (24VAC and 0-10VDC) (CLG) 24VAC signal applied to CLG of CN1. 1 <sup>st</sup> stage cooling relay (CLG) will actuate and supply 24VAC to Pin 9 of connector CN5. When 0-10VDC is applied to CLG, that control signal will passively be present at Pin 7 of the CN6 connector.	<ul style="list-style-type: none"> <li>CLG LED shows GREEN</li> <li>Signal for 1<sup>st</sup> stage cooling valve present</li> </ul>
F	Heating 1 <sup>st</sup> Stage (24VAC and 0-10VDC) (HTG) 24VAC signal applied to HTG of CN1. 1 <sup>st</sup> stage HTG relay will actuate and supply 24VAC to Pin 12 of connector CN5. When 0-10VDC is applied to HTG, that control signal will passively be present at Pin 8 of the CN6 connector.	<ul style="list-style-type: none"> <li>HTG LED shows GREEN</li> <li>Signal for 1<sup>st</sup> stage cooling valve present</li> </ul>
G	Fan Low Speed (24VAC) (LOW) 24VAC signal applied to LOW of CN1. The low speed PSC motor power relay and the low speed ECM signal relays will be activated. Line voltage will be present at Pin 2 of CN9 and the adjustable low speed ECM DC signal will be present at Pin 5 of the CN10 connector.	<ul style="list-style-type: none"> <li>LOW LED shows GREEN</li> <li>Signal for low speed present</li> </ul>
H	Fan Med Speed (24VAC) (MED) 24VAC signal applied to MED of CN1. The medium speed PSC motor power relay and the medium speed ECM signal relays will be activated. Line voltage will be present at Pin 3 of CN9 and the adjustable medium speed ECM DC signal will be present at Pin 5 of the CN10 connector.	<ul style="list-style-type: none"> <li>MED LED shows GREEN</li> <li>Signal for medium speed present</li> </ul>
I	Fan High Speed (24VAC) (HI) 24VAC signal applied to HI of CN1. High speed PSC motor power relay and the high speed ECM signal relays will be activated. Line voltage will be present at Pin 4 of CN9 and the adjustable high speed ECM DC signal will be present at Pin 5 of the CN10 connector..	<ul style="list-style-type: none"> <li>HI LED shows GREEN</li> <li>Signal for high speed present</li> </ul>
J	24VAC Board Power (24V) 24VAC signal supplied from internal transformer. 24VAC required for board operation.	<ul style="list-style-type: none"> <li>24V LED shows ORANGE</li> </ul>
K	0-10V ECM Speed Control (0-10V) 0-10V signal supplied to 10V of CN1. Signal passively present at Pin or CN10 connector..	<ul style="list-style-type: none"> <li>0-10 LED shows YELLOW</li> <li>Intensity of the LED illumination will vary depending on the amplitude of the 0-10VDC signal (10VDC is brightest)</li> </ul>
L	Power Supply by ECM (ECM) ECM Motor connected to CN10 and powered by line voltage. Signal from the ECM regulator is present at Pin 6 of the CN10 connector.	<ul style="list-style-type: none"> <li>ECM LED shows YELLOW</li> </ul>



# SECTION THREE – Controls Operation, Cont'd.

### Example Wiring Diagram

\*NOTE – Wiring diagram also available through QR code found on the unit serialized name plate label.

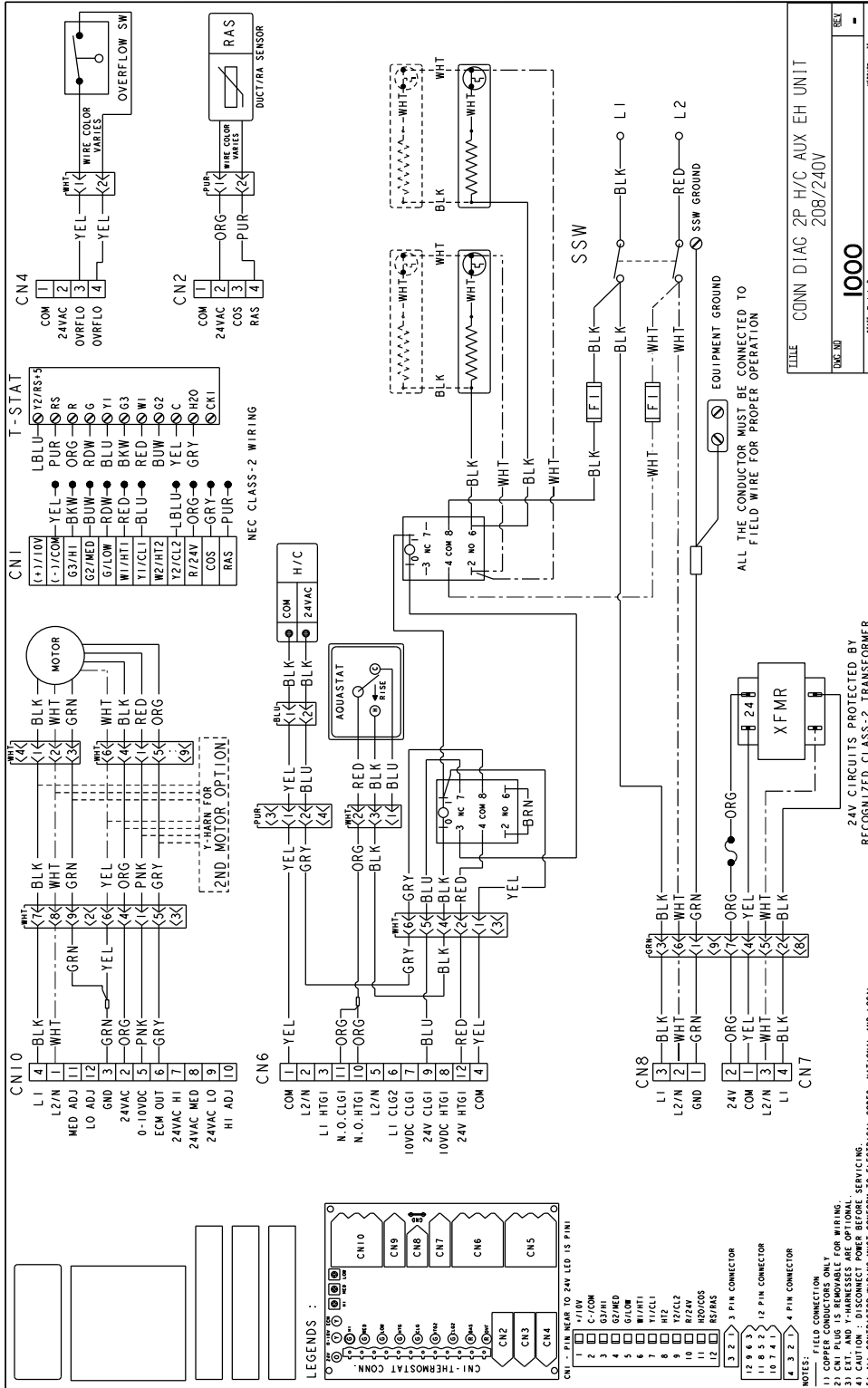

### SECTION FOUR – Normal Operation and Maintenance

#### SECTION FOUR – Normal Operation & Periodic Maintenance

##### General

Each unit on a job will have its own unique operating environment and conditions which may dictate a maintenance schedule for that unit that is different from other equipment on the job. A formal schedule of regular maintenance and an individual unit log should be established and maintained. This will help to achieve the maximum performance and service life of each unit on the job.

**Information regarding safety precautions contained in the preface at the beginning of this manual should be followed during any service and maintenance operations.**

For more detailed information concerning service operations consult your Sales Representative or the factory.

##### Motor/Blower Assembly

The type of fan operation is determined by the control components and their method of wiring. This may vary from unit to unit. Refer to the wiring diagram that is attached to each unit for that unit's individual operating characteristics.

All motors have permanently lubricated bearings. No field lubrication is required.

Should the assembly require more extensive service, the motor/blower assembly may be removed from the unit to facilitate such operations as motor or blower wheel/housing replacement, etc.

Dirt and dust should not be allowed to accumulate on the blower wheel or housing. This can result in an unbalanced blower wheel condition which can damage a blower wheel or motor. The wheel and housing may be cleaned periodically using a vacuum cleaner and a brush taking care not to dislodge the factory balancing weights on the blower wheel blades.

##### Bipolar Ionizer Brush Cleaning

The bipolar ionizer is designed to not require replacements parts.

The brushes on the device may become dirty over time and will require cleaning to maintain the effectiveness of ion output. Cleaning of bipolar ionizer brushes and inspection of device should be performed at time of each filter change or sooner, based on the location, filter effectiveness and general environment.

1. To clean the brushes, turn off power to the unit.  
**NOTE: When power is OFF, the green LED indicator on the device will not be illuminated.**
2. Using a small nylon brush, gently wipe off the two brushes. See Figure 39 for brush location.
3. After cleaning, restore power.

It is strongly recommended the bipolar ionizer be paired with a Pleated MERV 8 filter for most effective indoor air quality results.

Figure 39.

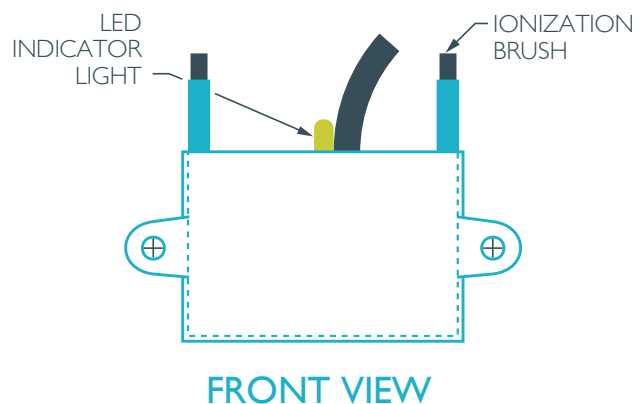

##### Coil

Coils may be cleaned by removing the motor/blower assemblies and brushing the entering air face between fins with a stiff brush. Brushing should be followed by cleaning with a vacuum cleaner. If a compressed air source is available, the coil may also be cleaned by blowing air through the coil fins from the leaving air face. This should



### SECTION FOUR – Normal Operation and Maintenance, Cont'd.

again be followed by vacuuming. Units provided with the proper type of air filters, replaced regularly, will require less frequent coil cleaning.

#### Electric Heater Assembly

Electric heaters typically require no normal periodic maintenance when unit air filters are changed properly. The operation and service life may be affected by other conditions and equipment in the system. The two most important operating conditions for an electric heater are proper air flow and proper supply voltage. High supply voltage and/or poorly distributed or insufficient air flow over the element will result in element overheating. This condition may result in the heater cycling on the high limit thermal cutout. Sheath heaters have automatic reset switches only. Open-strip heaters have an automatic reset switch with a back-up, high-limit thermal switch.

Automatic reset switches reset automatically after the heater has cooled down. High-limit thermal switches must be replaced once the circuit has been broken. The high-limit thermal cutout device is a safety device only, and is not intended for continuous operation. With proper unit application and operation, the high-limit thermal cutout will not operate. This device only operates when a problem exists, and ANY condition that causes high-limit cutout MUST be corrected immediately. High supply voltage also causes excessive amperage draw and may trip the circuit breaker or blow the fuses on the incoming power supply.

After proper air flow and supply power are assured, regular filter maintenance is important to provide clean air over the heater. Dirt that is allowed to deposit on the heating element will cause hot spots and eventual element burn through. These hot spots will normally not be enough to trip the high-limit thermal cut-out device, and may not be evident until actual heater element failure.

#### Typical Heater Types:

1. Exposed wire heater for CBY, CHY, CPY, CXB

Figure 40. for CBY, CHY, CPY, CXB.

NOTE – Size and number of elements varies with model.



2. Exposed wire heater for VEY.

Note: Heater located below the coil.

#### Electrical Wiring and Controls

The electrical operation of each unit is determined by the components and wiring of the unit. This may vary from unit to unit. Consult the wiring diagram attached to the unit for the actual type and number of controls provided on each unit.

The integrity of all electrical connections should be verified at least twice during the first year of operation. Afterwards, all controls should be inspected regularly for proper operation. Some components may experience erratic operation or failure due to age. Wall thermostats may also become clogged with dust and lint, and should be periodically inspected and cleaned to provide reliable operation.

When replacing any components such as fuses, contactors, or relays, use only the exact type, size and voltage component as furnished from the factory. Any deviation without factory authorization could result in personnel injury or damage to the unit. This will also void all factory warranties. All repair work should be done in such a manner as to maintain the equipment in compliance with governing codes, ordinances and testing agency listings.

# Fan Coils

## INSTALLATION, OPERATION, & MAINTENANCE MANUAL

### SECTION FOUR – Normal Operation and Maintenance, Cont'd.

More specific information regarding the use and operating characteristics of the standard controls offered by the manufacturer are contained in other manuals.

#### Valves and Piping

No formal maintenance is required on the valve-package components most commonly used with fan coil units other than a visual inspection for possible leaks in the course of other normal periodic maintenance. In the event that a valve should need replacement, the same precautions taken during the initial installation to protect the valve package from excessive heat should also be used during replacement.

#### Filters, Throwaway

The type of throwaway filter most commonly used on fan coil units should be replaced on a regular basis. The time interval between each replacement should be established based on regular inspection of the filter, and should be recorded in the log for each unit. Refer to the product catalog for the recommended filter size for each product type and size. If the replacement filters are not purchased from the factory, the filters used should be the same type and size as those furnished from, or recommended by the factory. Pleated media, or extended surface filters should not be used since the high air pressure drops encountered with these types of filters is not compatible with the type of fan coil unit covered in this manual. Consult the factory for applications using filter types other than the factory standard or optional product.

#### Filters, Permanent

A maintenance schedule for permanent filters should be developed in the same manner as throwaway filters. Unlike throwaway filters, permanent filters may be cleaned and re-installed in the unit instead of being discarded when dirty. The optional factory permanent filter may be cleaned in hot soapy water to remove any trapped dirt. It should then be set aside on edge to dry.

Before replacing the filter in the unit, it should be recharged with some type of entrapment film such as "Film-Cor Recharging Oil." The filter should be sprayed on both sides or submerged in the film to assure complete coverage. The filter should not be allowed to soak in the film, but should be immediately removed and the excess film drained from the filter before re-installation in the unit. Consult a local filter supplier for types of available cleaning solutions and charging films.

It should be noted that permanent filters normally have less static pressure loss than throwaway filters.

#### Drain

The drain should be checked before initial start-up, and at the beginning of each cooling season to assure that the drain, drain trap, and line are clear. If it is clogged, steps should be taken to clear the debris so that condensate will flow easily.

Periodic checks of the drain should be made during the cooling season to maintain a free-flowing condensate. Units provided with a secondary or "tell-tale" drain connection will indicate a clogged main-drain line by flow from the "tell-tale" connection.

Should the growth of algae and/or bacteria be a concern, consult an air conditioning and refrigeration supply organization familiar with local conditions for chemicals, or other solutions available to control these agents.

## **SECTION FOUR – Normal Operation and Maintenance, Cont'd.**

### **Replacement Parts**

Factory replacement parts should be used wherever possible to maintain unit performance, it's normal operating characteristics, and the testing agency listings. Replacement parts may be purchased through a local Sales Representative.

Contact the local Sales Representative or the factory before attempting any unit modifications. Any modifications not authorized by the factory could result in personnel injury, damage to the unit, and could void all factory warranties.

When ordering parts, the following information must be supplied to ensure proper part identification:

- (1) Complete unit model number
- (2) Unit serial number
- (3) Complete part description, including any numbers

For warranty parts inquiries, in addition to the information previously listed, a description of the issue with the parts is required. Contact the factory for authorization to return any parts, such as defective parts, to be replaced in warranty. All shipments returned to the factory must be marked with a **Return Authorization Number** which is provided by the factory, if warranty has been approved.

On warranty replacements, in addition to the information previously listed, the unit shipping code which appears on the upper right-hand corner of the serial plate is required. Contact the factory for authorization to return any parts such as defective parts replaced in warranty. All shipments returned to the factory must be marked with a Return Authorization Number which is provided by the factory.

# Fan Coils

## INSTALLATION, OPERATION, & MAINTENANCE MANUAL

### SECTION FIVE – Equipment Start-Up Checklist

#### IMPORTANT

Fan coil units must be filled with water before operating the circulator. The circulator bearings are water lubricated and should not be allowed to operate dry. Filling the system properly will result in immediate lubrication of the bearings.

#### Receiving and Inspection

- Unit received undamaged
- Unit received complete as ordered
- “Furnish only” parts accounted for
- Unit arrangement/hand correct
- Unit structural support complete and correct

#### Handling and Installation

- Mounting grommets/isolators used
- Unit mounted level and square
- Proper access provided for unit and accessories
- Proper electrical service provided
- Proper over-current protection provided
- Proper service switch/disconnect provided
- Proper chilled water line size to unit
- Proper hot water line size to unit
- All services to unit in code compliance
- All shipping screws and braces removed
- Unit protected from dirt and foreign matter

#### Cooling/Heating Connections

- Protect valve package components from heat
- Mount valve packages
- Connect field piping to unit
- Pressure test all piping for leaks
- Install drain line and traps, as required
- Insulate all piping, as required
- Install drip lip under piping, as required

#### Ductwork Connections

- Install ductwork, fittings and grilles, as required
- Flexible duct connections at unit
- Proper supply and return grille type and size
- Control outside air for freeze protection
- Insulate all ductwork, as required

#### Electrical Conditions

- Refer to unit wiring diagram
- Connect incoming power service or services
- Install and connect “furnish only” parts

#### Unit Start-up

- General visual unit and system inspection
- Check for proper fan rotation
- Record electrical supply voltage
- Check all wiring for secure connections
- Close all unit isolation valves
- Flush water systems

#### Adjustment of E025-71521512 3-Speed Pot Board

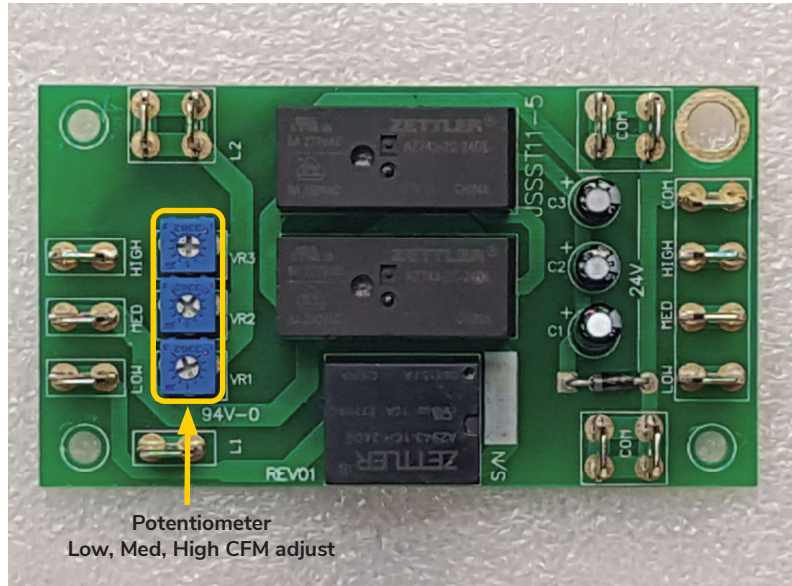

The unit has been factory configured to produce PSC equivalent airflow on high speed, with medium and low speed set at 80% and 60% of high, respectively. If these settings are acceptable, then no further configuring is required.

If alternative airflows are desired, use board mounted pots to adjust the airflow associated with each input. Each output can be adjusted from 0 to 100% of the motor's factory programmed operating range. Use voltmeter and airflow chart (on control box cover) to set values.

To reset to initial factory settings, reference the voltages found on the sticker next to the pots.

Adjusting the Low, Medium, and High potentiometers requires the use of a Multi-meter capable of measuring 0~5 vdc.

1. Only trained and qualified individuals should attempt to adjust or service components on any electrical component. Failure to follow safety rules could result in electrical shock or hazard.
2. Unit must be powered to perform the following procedure. If main power is not available, IEC

recommends connecting a temporary 24V-40VA power supply in parallel with the secondary outputs of the unit's transformer.

3. Set the electrical multimeter to Volts Direct Current (Vdc) on the 0~5 or 0~20 Vdc scale.
4. Attach black (negative) lead of meter to the DC common terminal, labeled "L2" above the potentiometers.
5. Attach the red (positive) lead of the meter to the red wire that bridges the 0-10VDC outputs: high, medium, and low.
  - a. High Speed: Using a small screwdriver, turn the H ADJ potentiometer (CW for increasing speed, CCW for decreasing speed).
  - b. Medium Speed: Using a small screwdriver, turn the M ADJ potentiometer (CW for increasing speed, CCW for decreasing speed).
  - c. Low Speed: Using a small screwdriver, turn the L ADJ potentiometer (CS for increasing speed, CCW for decreasing speed).



# Fan Coils

## INSTALLATION, OPERATION, & MAINTENANCE MANUAL

### TERMS AND CONDITIONS

- Orders shall not be binding upon International Environmental Corporation, an Oklahoma corporation (hereinafter referred to as "IEC") unless accepted by an authorized representative of IEC at its office in Oklahoma City, Oklahoma. No distributor, sales representative or any other person or entity (except authorized employees of IEC at its office in Oklahoma City, Oklahoma) has any authority whatsoever to bind IEC to any representation or agreement of any kind.
- IEC does not build items to plans and specifications. IEC agrees to furnish only the items as described in IEC's acknowledgment unless IEC's office in Oklahoma City, Oklahoma has previously received and accepted, in writing, approved submittals from Purchaser.
- Prices acknowledged are firm only if Purchaser releases the goods covered by this order for immediate production by IEC within sixty (60) days from the date of Purchaser's initial offer to purchase and for shipment by IEC within IEC's estimated shipping date, unless otherwise agreed to in writing by IEC at its office in Oklahoma City, Oklahoma. If Purchaser does not meet the terms and conditions of this paragraph, the prices are subject to escalation to those prices in effect at time of shipment without notice to Purchaser.
- All prices are F.O.B. IEC's factory, unless otherwise agreed by IEC in writing; and, all payments and prices shall be in U.S.A. dollars.
- If goods are released for production but IEC is prevented by the Purchaser from shipping upon completion or by IEC's estimated shipping date, whichever is later, IEC may at its option, in addition to all other remedies, invoice Purchaser to be payable within thirty (30) days and store the goods at Purchaser's sole expense.
- Title to and risk of loss to the goods passes to the Purchaser F.O.B. IEC's factory.
- Disclaimer**  
It is expressly understood that unless a statement is specifically identified as a warranty, statements made by IEC or its representatives relating to IEC's products, whether oral, written or contained in any sales literature, catalog or any other agreement, are not express warranties and do not form a part of the basis of the bargain, but are merely IEC's opinion or commendation of IEC's products. **EXCEPT AS SPECIFICALLY SET FORTH HEREIN, THERE IS NO EXPRESS WARRANTY AS TO ANY OF IEC'S PRODUCTS. IEC MAKES NO WARRANTY AGAINST LATENT DEFECTS. IEC MAKES NO WARRANTY OF MERCHANTABILITY OF THE GOODS OR OF THE FITNESS OF THE GOODS FOR ANY PARTICULAR PURPOSE.**
- Grant of Limited Express Warranty**  
IEC warrants IEC products purchased and retained in the United States of America and Canada to be free from defects in material and workmanship under normal use and maintenance as follows: (1) All complete fan coil units built or sold by IEC for twelve (12) months from date of unit start up or eighteen (18) months from date of shipment (from factory), whichever comes first.  
  
All parts must be returned to IEC's factory in Oklahoma City, Oklahoma, freight prepaid, no later than sixty (60) days after the date of the failure of the part; if IEC determines the part to be defective and within IEC's Limited Express Warranty, IEC shall, when such part has been either replaced or repaired, return such to a factory recognized contractor or service organization, F.O.B. IEC's factory, Oklahoma City, Oklahoma, freight prepaid. The warranty on any parts repaired or replaced under warranty expires at the end of the original warranty period. For information and warranty service contact:  
  
International Environmental Corporation  
Customer Service  
5000 West I-40  
Oklahoma City, OK 73128  
(405) 605-5000  
  
This warranty does not cover and does not apply to: (1) Air filters, fuses, fluids; (2) Products relocated after initial installation; (3) Any portion or component of any system that is not supplied by IEC, regardless of the cause of the failure of such portion or component; (4) Products on which the unit identification tags or labels have been removed or defaced; (5) Products on which payment to IEC is or has been in default; (6) Products which have defects or damage which result from improper installation, wiring, electrical imbalance characteristics or maintenance; or are caused by accident, misuse or abuse, fire, flood, alteration or misapplication of the product; (7) Products which have defects or damage which result from a contaminated or corrosive air or liquid supply or operation at abnormal temperatures; (8) Mold, fungus or bacteria damages; (9) Products subjected to corrosion or abrasion; (10) Products manufactured or supplied by others; (11) Products which have been subjected to misuse, negligence or accidents; (12) Products which have been operated in a manner contrary to IEC's printed instructions; or (13) Products which have defects, damage or insufficient performance as a result of insufficient or incorrect system design or the improper application of IEC's products.  
  
IEC is not responsible for: (1) The cost of any fluids or other system components, or associated labor to repair or replace the same, which is incurred as a result of a defective part covered by IEC's Limited Express Warranty; (2) The costs of labor, materials or service incurred in removal of the defective part, or in obtaining and replacing the new or repaired part; or, (3) Transportation costs of the defective part from the installation site to IEC or of the return of any part not covered by IEC's Limited Express Warranty.  
  
**Limitation:** This Limited Express Warranty is given in lieu of all other warranties. If, notwithstanding the disclaimers contained herein, it is determined that other warranties exist, any such warranties, including without limitation any express warranties or any implied warranties of fitness for particular purpose and merchantability, shall be limited to the duration of the Limited Express Warranty.
- Limitation of Remedies**  
In the event of a breach of the Limited Express Warranty, IEC will only be obligated at IEC's option to repair the failed part or unit or to furnish a new or rebuilt part or unit in exchange for the part or unit which has failed. If after written notice to IEC's factory in Oklahoma City, Oklahoma of each defect, malfunction or other failure and a reasonable number of attempts by IEC to correct the defect, malfunction or other failure and the remedy fails of its essential purpose, IEC shall refund the purchase price paid to IEC in exchange for the return of the sold good(s). Said refund shall be the maximum liability of IEC. THIS REMEDY IS THE SOLE AND EXCLUSIVE REMEDY OF THE BUYER OR THEIR PURCHASER AGAINST IEC FOR BREACH OF CONTRACT, FOR BREACH OF ANY WARRANTY OR FOR IEC'S NEGLIGENCE OR IN STRICT LIABILITY.
- Limitation of Liability**  
IEC shall have no liability for any damages if IEC's performance is delayed for any reason or is prevented to any extent by any event such as, but not limited to: any war, civil unrest, government restrictions or restraints, strikes, or work stoppages, fire, flood, accident, shortages of transportation, fuel, material or labor, acts of God or any other reason beyond the sole control of IEC. **IEC EXPRESSLY DISCLAIMS AND EXCLUDES ANY LIABILITY FOR CONSEQUENTIAL OR INCIDENTAL DAMAGE IN CONTRACT, FOR BREACH OF ANY EXPRESS OR IMPLIED WARRANTY, OR IN TORT, WHETHER FOR IEC'S NEGLIGENCE OR AS STRICT LIABILITY.**
- IEC shall have no system design, application or maintenance responsibility or responsibility for mold, fungus or bacteria to Purchaser or any other third party.
- All sales, goods and services, use, excise, value added, transportation, privilege, occupational consumption, storage, document, transaction or other taxes which may be levied by any taxing authority as a result of this transaction shall be paid by the Purchaser.
- Unless otherwise agreed to in writing by IEC any technical data furnished in conjunction with this order and not obtainable from another source shall not be duplicated, used, or disclosed in whole or in part for any purpose other than to evaluate this order.
- IEC shall have no liability or other obligation hereunder, if IEC's performance is delayed for any reason or is prevented to any extent by any event such as, but not limited to: any act of God, strike or work stoppage, fire, flood, accident, allocation, or other controls of Government authorities, shortages of transportation, fuel, material or labor, or any other cause beyond IEC's sole control. Any shipping date stated by IEC is IEC's best estimate but IEC makes no guarantee of shipment by any such date and shall have no liability or other obligation for failure to ship on such date, regardless of cause.
- Payment terms are net thirty (30) days from date of shipment on approved credit. One and one half percent (1 1/2%) per month (18% annual rate) may be charged on past due accounts or the highest rate permitted by applicable law, whichever is lesser. In the event the account is placed for collection, Purchaser shall be responsible for all reasonable attorneys fees or costs on a solicitor and client basis, plus all other costs and expenses incurred by IEC in securing payment.
- Purchaser shall not cancel the contract without prior written consent of an authorized representative of IEC at its offices in Oklahoma City, Oklahoma. In the event Purchaser cancels the contract with the prior written consent of IEC after the Purchaser's offer to purchase is received and acknowledged in writing, IEC shall be entitled to receive from Purchaser IEC's cost incurred to time of cancellation plus a reasonable allowance for overhead and profit.
- Purchaser shall not assign any of its interest or rights under this agreement without written consent of IEC.
- IEC will protect all its lien rights. IEC will not furnish lien waivers or releases until IEC receives payment, in full, at its office in Oklahoma City, Oklahoma from Purchaser for the goods covered by this order. There is no authorized retainage for any reason.
- This Agreement shall be construed, and the rights and liabilities of the parties hereunder shall be determined in accordance with the laws of the State of Oklahoma. If it shall be found that any portion of this agreement violates any particular law of the United States or any state in the United States having jurisdiction or, if applicable, any law of Canada or any province or territory in Canada having jurisdiction, such portion of the agreement shall be of no force and effect in that political unit, division or sub-division in which they are illegal or unenforceable and the agreement shall be treated as if such portion or portions had not been inserted. In the event that any dispute or disagreement in connection with any order should arise or exist between Purchaser and IEC, jurisdiction and venue for any legal action shall be, if IEC so elects, exclusively in the state or federal courts in Oklahoma County, Oklahoma. The statute of limitations on any claim of the Purchaser against the IEC shall be one (1) year from the date the cause of action accrues.
- Without regard to any other agreement, all obligations of Purchaser to IEC shall become immediately due and payable if Purchaser becomes insolvent or if Purchaser does not make payments when due or breaches any other agreement or fails to perform any obligation.
- All orders are expressly limited and made conditional upon acceptance by Purchaser of the terms and conditions set forth above without change. There shall be no understandings, agreements, or obligations (outside these terms and conditions) unless specifically set forth in writing and accepted by signature of an authorized representative of IEC in Oklahoma City, Oklahoma.
- The parties hereto have requested that these presents and all judicial proceedings relating thereto be drafted in English. Les parties aux présentes ont demandé à ce que les présentes et toutes procédures judiciaires y afférentes soient rédigées en anglais

This page intentionally left blank.



This page intentionally left blank.

This page intentionally left blank.

# Fan Coils

## INSTALLATION, OPERATION, & MAINTENANCE MANUAL



Contact your local IEC Sales Representative for further details and pricing applicable to this product. Visit our website ([iec-okc.com](http://iec-okc.com)) to find your local IEC Sales Rep.

IEC Part Number: I100-90000950  
IOM-100 Revision 16.2 (10/2023)  
©2000-2023 International Environmental Corporation (IEC)



5000 W. I-40 Service Rd.  
Oklahoma City, OK 73128  
P: 405.605.5000  
F: 405.605.5001  
[www.iec-okc.com](http://www.iec-okc.com)

# REVIEW OF MECHANICAL SUBMITTALS

**Project:** LR Statehouse Conv. Center - Atrium  
**Location:** Little Rock, AR  
**Date of Receipt:** Tuesday, June 13, 2023  
**Date of Review:** Wednesday, June 14, 2023  
**Reviewed by:** Stephen Jewell  
**Email:** [sjewell@pettitinc.com](mailto:sjewell@pettitinc.com)

P&P Job No. 23-023

Signed: 

Checking is for conformance with the design concept of the Project and compliance with the information given in the Contract Documents. The Contractor is responsible for dimensions to be confirmed and correlated at the job site; for information that pertains solely to the fabrication processes or to techniques of construction; and for coordination of the work of all trades.

Item	Approval Status		Comments
Section 23 82 19 – Terminal Heat Transfer Units – Fan Coil Units	Approved as Noted	○	<ul style="list-style-type: none"> <li>- Verify handing prior to ordering.</li> <li>- Coordinate exact controls requirements – see keyed note #6, sheet MP1.01.</li> <li>- Provide motor with auto reset on thermal overload as per specifications.</li> <li>- Provide with motor control relays as per specifications.</li> <li>- Provide with Belimo control valves (no equal) as per specifications.</li> <li>- Provide with spare filter set as per specifications.</li> </ul>
Section 23 05 93 – Testing, Adjusting, and Balancing (TAB) for HVAC	Approved as Noted	○	<ul style="list-style-type: none"> <li>- Preliminary paperwork approved, provide final TAB report for A/E review and approval prior to scheduling final punch site visit.</li> </ul>



Note:

## SHOP DRAWING / SUBMITTAL REVIEW

- REVIEWED  REVIEWED WITH CHANGES NOTED  
 REVISE AND RESUBMIT  REJECTED \_\_\_\_\_

This review is for general conformance with plans and specifications only. Approvals are subject to subcontractors performance within the confines of the contract documents. Review of dimensions will not serve to relieve the subcontractor of contractual responsibility for any deviation from the contract requirements.

By: **Josh Brandon** Date: **5/15/23**

Wagner General Contractors, Inc.

Submittal for job: **Convention Center Atrium LRCVB / LRCVBU22.03**

Submittal Number: **Division 23**

Submittal Type: **HVAC**

Subcontractor: **Comfort Systems USA**

Date Sent to Architect: **5/15/23**

Please respond by: **5/22/23**

Project Name: **LRCVB Atrium**

Reviewer Name: Josh Brandon

Date: 05/15/2023

Submittal #: 12

Company Name: Wagner General Contractors, Inc.

**Status: Reviewed**

This review is only for general conformance of the project and general compliance. Contractor is responsible for all dimensions and fabrication to be confirmed and correlated at the job site.



## **SUBMITTAL DATA**

EQUIPMENT: IEC Lowboy Fan Coil Unit

TAGS: FCU-1

PROJECT: LR Statehouse Convention Center- East Lobby Atrium

LOCATION: Little Rock, AR

ENGINEER:



CONTRACTOR:



DATE: 5/9/2023

SUBMITTED BY: Forrest Moseley  
forrest@airetechcorp.com  
0

**PROJECT SUBMITTAL**

5/9/2023



Project Name: LRCVB Replacment  
 Project Location:  
 Created by: Forrest Moseley  
 Printed Date: 5/9/2023 8:09 AM  
 Selection Date: 3/16/2023 11:25 AM  
 Last Revision: 5/9/2023 8:09 AM

INTERNATIONAL ENVIRONMENTAL CORPORATION  
 5000 I-40 West Service Road  
 Oklahoma City, OK 73128  
 PH: 405-605-5000  
 Quote #: QT163099-0

Unit Tag: Qty: 1 Model: LXW06 System: 4-Pipe Hydronic Heat/ Hydronic Cool

**Unit Data**

Motor Type:	PSC Standard	Coil Hand:	RH
Motor HP:	0.080	Coil Tube Dia:	0.50 in
Motor FLA:	3.2 Amps	Coil Face Area:	3.06 ft^2
Motor Watts:	-	Cooling Coil Connection:	0.50 in
Unit MCA:	3.6 Amps	Heating Coil Connection:	0.50 in
Unit MFS:	15.000 Amps	Weight (Dry):	164 lbs
Unit Volt:	115/1/60	Weight (Wet):	174 lbs
		Fan Speed:	H
		Filter Size:	7 x 48.75 x 1 in
		Filter Face Area:	2.37 ft^2
		Filter Type:	1" Pleated (MERV 8) Filter

Performance Data	Unit Configuration
------------------	--------------------

Altitude:	0	Ft
Air Flow Rate:	600	CFM
ESP:	0.00	in WC
Coil Face Velocity:	196	Ft/Min

Cooling Performance		
Fluid:	Water	
EAT DB/WB:	80.0 / 67.0	F
LAT DB/WB:	56.7 / 55.2	F
Total Capacity:	22087	BTUH
Sensible Capacity:	15401	BTUH
EWT/LWT:	45.0 / 54.7	F
Fluid FLOW:	4.500	GPM
Fluid P.D.:	12.2	Ft WC
Rows / FPI / Circuits:	3 / 12 / 2	

Heating Performance		
Fluid:	Water	
EAT DB/WB:	70.0	F
LAT DB/WB:	113.9	F
Total Capacity:	29055	BTUH
EWT/LWT:	180.0 / 150.4	F
Fluid FLOW:	2.000	GPM
Fluid P.D.:	5.0	Ft WC
Rows / FPI / Circuits:	1 / 12 / 1	

**LXW - Lowboy Cabinet Tall**

Unit & Size-LXW Unit Size 06  
 Coil-3 Row Cooling/1 Row Heating (4 Pipe) SE Conn  
 Coil Hand-Right Hand Coil  
 CoilTestPressure-350 PSIG  
 Coil Option-Union Conn at Coil (4 Pipe) at 1/2" C and H  
 Motor-Standard PSC Blower Motor 115/1/60  
 Outside Air-No Outside Air Accessories  
 Tstat-Venstar Digital 7-Day Unit Mt w/ Logo  
 Cntrl Pkg-4 Pipe H/C (24V 3Spd)  
 Cntrl Option-20 amp Serv Switch (Non Fused)  
 Ctrl Option-Condensate Overflow Sw  
 Primary Valve Package - 1/2"  
 Cntrl Vlv-2-Way (NC, 25 psi)  
 Flow Cntrl Vlv-Fixed 4.5 GPM at 1/2"  
 Isolation Vlv-2 Ball Vlvs at 1/2"  
 Vlv Option-PT Port (Coil Supply and Return)  
 Vlv Option-Y Strainer w/ Blowdown at 1/2"  
 Secondary Valve Package - 1/2"  
 Cntrl Vlv-2-Way (NC, 25 psi)  
 Flow Cntrl Vlv-Fixed 2.0 GPM at 1/2"  
 Isolation Vlv-2 Ball Vlvs at 1/2"  
 Vlv Option-PT Port (Coil Supply and Return)  
 Vlv Option-Y Strainer w/ Blowdown at 1/2"  
 Return Air-Open Return  
 Supply Air-DD Aluminum Finish (F and I)  
 Filter-1" Pleated (MERV 8) filter  
 Drain Pan-Stainless Steel with Ext Ins and Poly Aux Pan  
 Paint-Ermine Gray Powder Coat  
 Cabinet Ins-1/2" Standard Fiberglass  
 Access Door-Access Doors for Galvanized Cabinet  
 Cabinet Option-Galv Steel Lev Legs 1"  
 Packaging-Box and Palletize Units

Sound Power							
Octave Band (dB Re 10 <sup>12</sup> Watts)							
Frequency:	125	250	500	1K	2K	4K	8K
Casing:	67	70	65	63	59	54	50
Discharge:	0	0	0	0	0	0	0

International Environmental Corporation (IEC) works continually to improve its products. As a result, the design and specifications of each product may be changed without notice and may not be as described herein. Please contact IEC for information regarding current design and product specifications. Statements and other information contained herein are not express warranties and do not form the basis of any bargain between the parties but are merely IEC's opinion or commendation of its products. Manufacturer's standard limited warranty applies.



**PROJECT SUBMITTAL**

5/9/2023



Project Name: LRCVB Replacment  
Project Location:  
Created by: Forrest Moseley  
Printed Date: 5/9/2023 8:09 AM  
Selection Date: 3/16/2023 11:25 AM  
Last Revision: 5/9/2023 8:09 AM

INTERNATIONAL ENVIRONMENTAL CORPORATION

5000 I-40 West Service Road  
Oklahoma City, OK 73128  
PH: 405-605-5000  
Quote #: QT163099-0

Unit Tag: Qty: 1 Model: LXW06 System: 4-Pipe Hydronic Heat/ Hydronic Cool

**Unit Connections Configuration**



**FRONT**

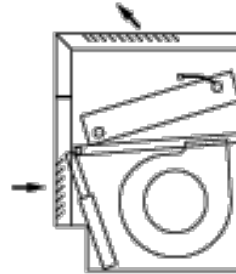

**RIGHT**

Supply: DD Aluminum Finish (F and I)  
Return: Open Return

Coil Hand: RH  
Electrical Box: LH

**Unit Typical ISO View**

**Unit Tag**

International Environmental Corporation (IEC) works continually to improve its products. As a result, the design and specifications of each product may be changed without notice and may not be as described herein. Please contact IEC for information regarding current design and product specifications. Statements and other information contained herein are not express warranties and do not form the basis of any bargain between the parties but are merely IEC's opinion or commendation of its products. Manufacturer's standard limited warranty applies.

REVISION HISTORY		
REV	DATE	ECN
-	03/11/21	21-0295

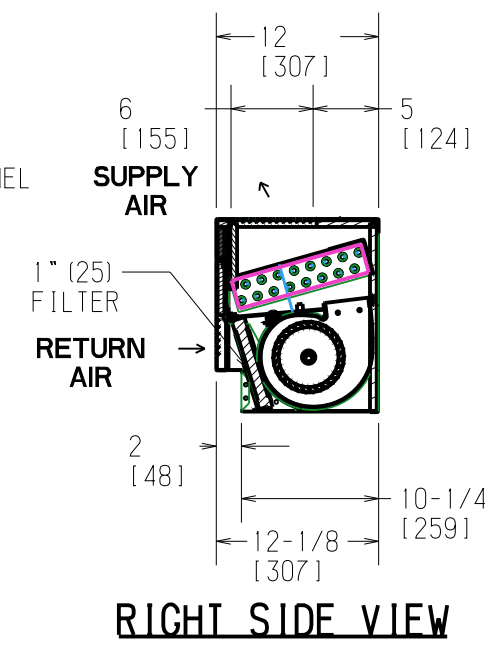
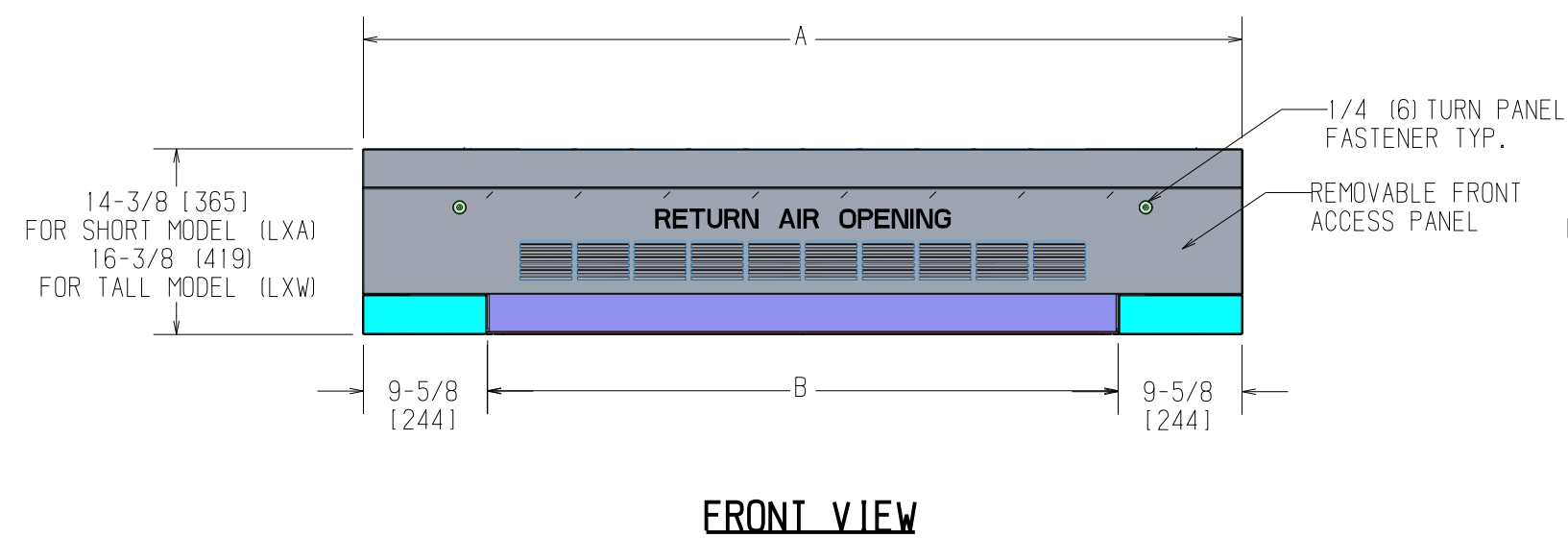
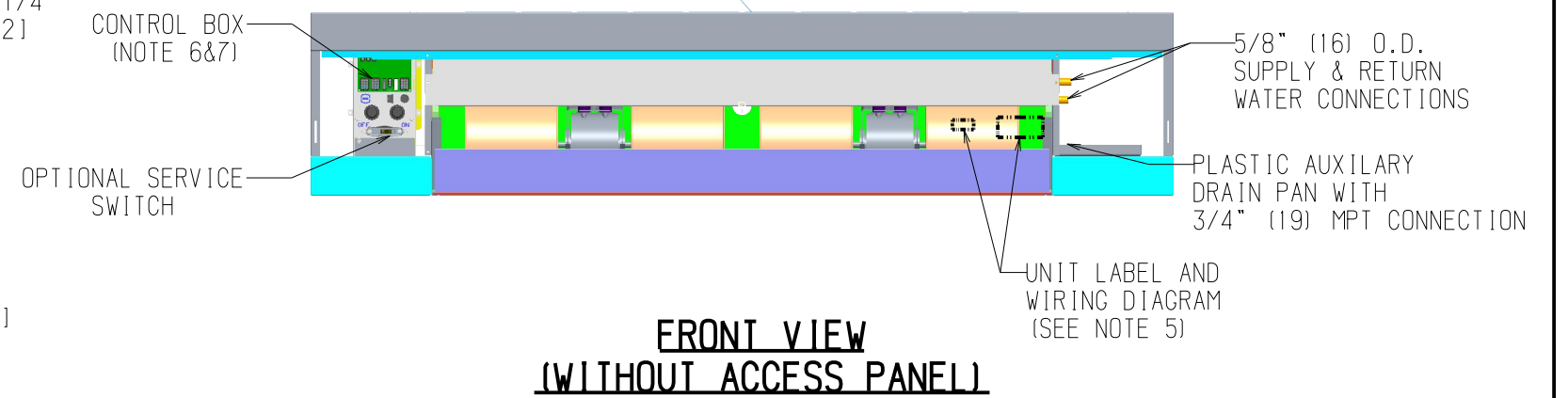
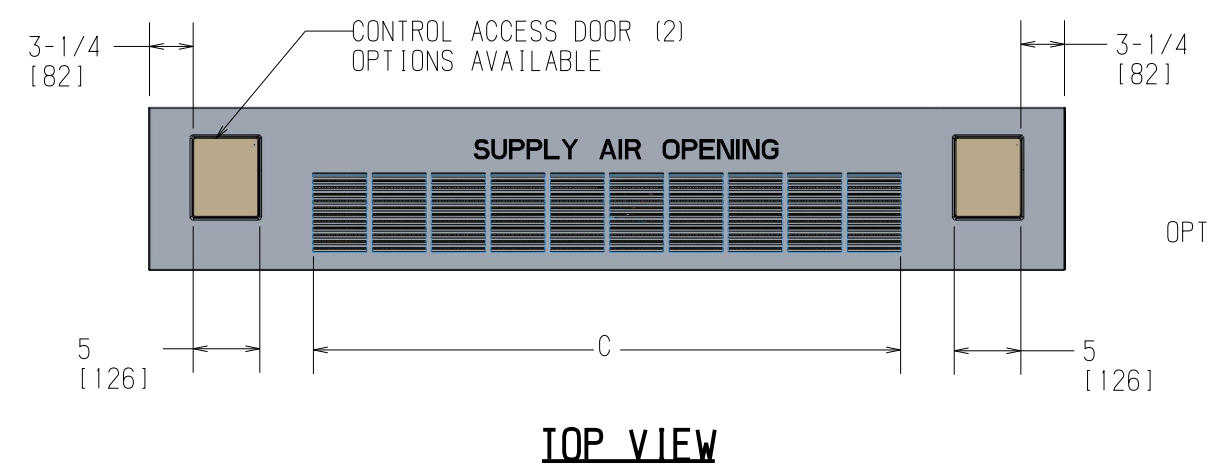

- NOTES:
1. RH COIL SHOWN. LH OPPOSITE.
  2. ALL DIMENSIONS ARE +/- .25 (6). DRAWING NOT TO SCALE.
  3. PRODUCT SPECIFICATIONS ARE SUBJECT TO CHANGE WITHOUT NOTICE.
  4. CONTROL BOX SIZE AND POSITION MAY VARY (CONSULT FACTORY)
  5. POSITION MAY VARY.
  6. SERVICE ACCESS IS LOCATED ON THE FRONT OF THE CONTROL BOX.
  7. KNOCKOUTS ON THE BOTTOM AND SIDE OF THE CONTROL BOX FOR INCOMING POWER CONNECTIONS

Unit Model	Dimensions - Inches (Millimeters)			Quantity/Unit	
	A	B	C	Blower	Motor
LXA/LXW 02	41 (1041)	22 (559)	17 (432)	2	1
LXA/LXW 03	46 (1168)	27 (686)	21-1/2 (546)	2	1
LXA/LXW 04	54 (1372)	35 (889)	30-1/4 (768)	2	1
LXA/LXW 06	68 (1727)	49 (1245)	43-3/8 (1102)	4	2



**IEC**  
International  
Environmental

TITLE		VERT LOWBOY CABINET LXA/LXW	
DWC NO			REV
<b>1100-90044514</b>			-
DRAWN	DATE	APPROVED	DATE
K.LIETZ	03/20/12	J.GRAVES	03/20/12

EntityID;EntityRev: QT163099;0

Applies to Lines: 1

Project: LRCVB Replacment

Date Generated: 5/9/2023 8:09 AM

LEGEND	
	PIPE
	AIR VENT
	UNION
	SWAGE
	PT PORT
	PETE'S PLUG
	2-WAY MOTORIZED VALVE
	3-WAY MOTORIZED VALVE
	BALANCE VALVE
	CIRCUIT SETTER
	FIXED FLOW VALVE
	STRAINER
	STRAINER W/BLOWDOWN
	AQUASTAT
	CHANGE OVER
	THREADED ADAPTER
	BALL VALVE
	BALL VALVE ON THE RISER
	HOSEKIT
	COMBINATION SUPPLY
	COMBINATION RETURN
	SUREFLOW PUMP

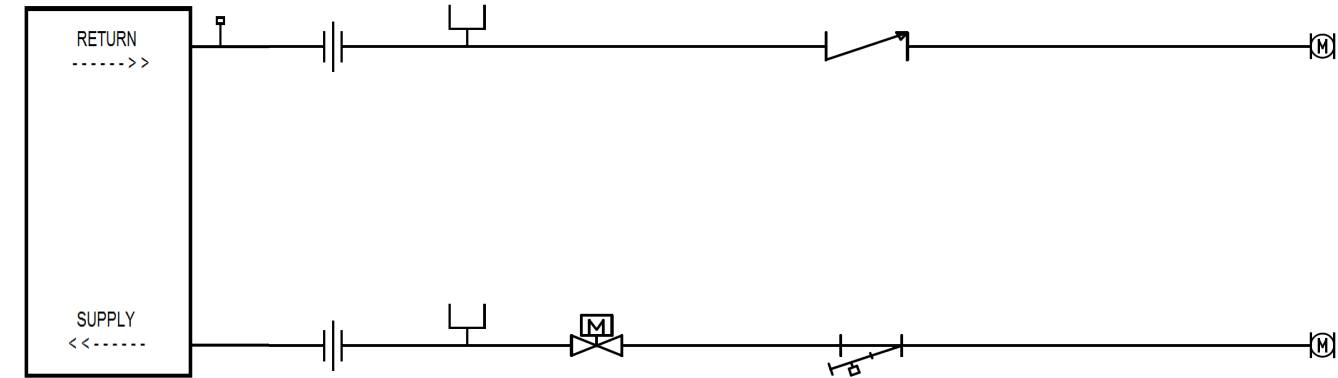

SECONDARY COIL

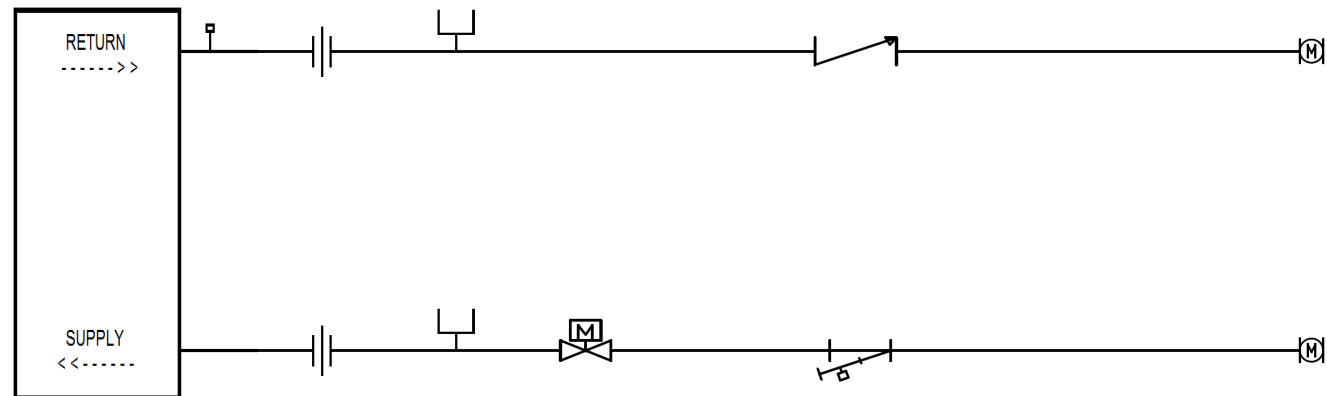

PRIMARY COIL

NOTES:

1. THIS DOCUMENT IS FOR REFERENCE ONLY AND NOT AN AS BUILT DRAWING.
2. VALVE PACKAGE MAY BE FIELD OR FACTORY INSTALLED.
3. SOME COMPONENTS MAY BE PRESENT IN ANOTHER ASSEMBLY AND SHOWN FOR CLARIFICATION ONLY.
4. AIR VENTS AND OPTIONAL COIL DRAIN (WHEN SPECIFIED) MOUNTED ON COIL.

	INTERNATIONAL ENVIRONMENTAL
	TITLE VALVE PACKAGE LAYOUT

EntityID;EntityRev: QT163099;0

Applies to Lines: 1

Project: LRCVB Replacment

Date Generated: 5/9/2023 8:09 AM

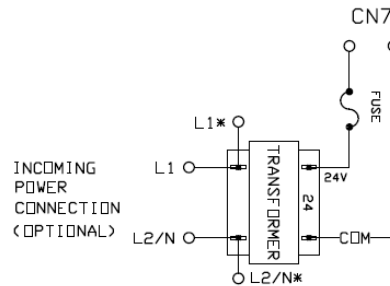
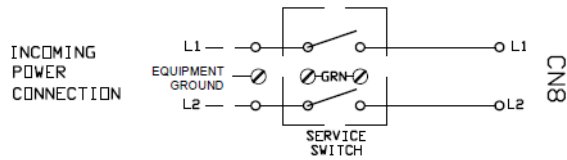
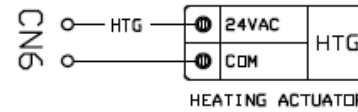
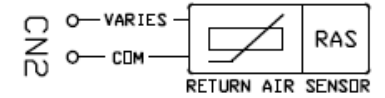
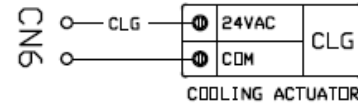
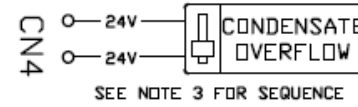
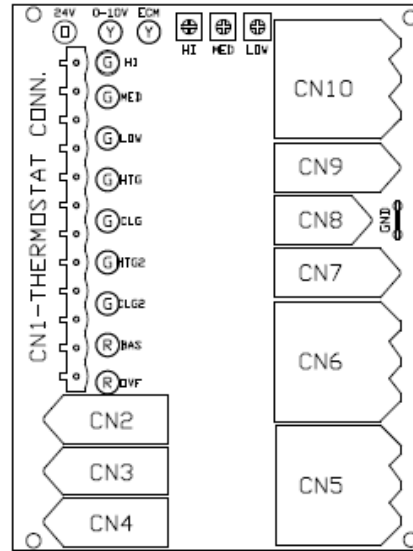
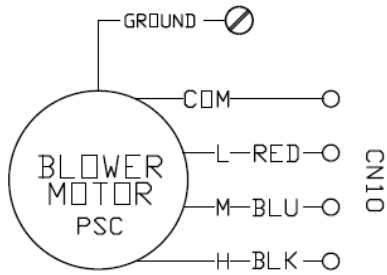
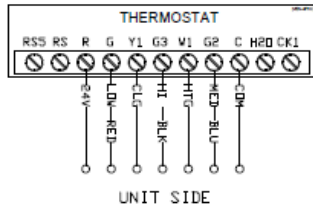

NOTES:

1. PRODUCT SPECIFICATIONS ARE SUBJECT TO CHANGE WITHOUT NOTICE.
2. NOT AS BUILT DRAWING, CONTACT FACTORY FOR ACTUAL WIRING CONFIGURATION.
3. CONDENSATE OVERFLOW SWITCH TO INTERRUPT 24V POWER TO UNIT UNLESS SPECIFIED OTHERWISE.

	INTERNATIONAL ENVIRONMENTAL
	TITLE ELECTRICAL SUBMITTAL 4 PIPE HTG/ CLG



## 1/2", 3/4" Ball Valve, Sweat

Valve Information	
<b>Manufacturer</b>	Nexus
<b>Type, Model</b>	Ultra NX, NXS-0XXS
<b>Customer Furnished</b>	No
<b>IEC Furnished</b>	Yes
<b>Factory Packaged for Field Mounting</b>	Yes

Materials		Dimensions – see drawing above	
<b>Body, End Pieces</b>	Hot Forged Brass ASTM, 600 WOG, 325°F	<b>B (in)</b>	2.3 (1/2") 3.0 (3/4")
<b>Handle &amp; Nut</b>	Aluminum	<b>E (in)</b>	1.5 (1/2") 1.7 (3/4")
<b>Ball</b>	Chrome Plated Brass	<b>F (in)</b>	1.6 (1/2") 1.6 (3/4")
<b>Ball Seals</b>	Teflon	<b>Ball I.D.</b>	0.5 (1/2") 0.8 (3/4")
<b>Shaft Seals</b>	Dual Viton/ EPDM O-Rings	<b>Cv</b>	17 (1/2") 40 (3/4")
<b>Memory Stop</b>	Stainless Steel	<b>WT (lbs)</b>	0.3 (1/2") 0.6 (3/4")
<b>Size</b>	1/2", 3/4"		
<b>Sweat</b>	Yes		
<b>Threaded</b>	No		

International Environmental Corporation (IEC) © works continually to improve its products. As a result, the design and specifications of each product may be changed without notice and may not be as described herein. Please contact IEC for information regarding current design and product specifications. Statements and other information contained herein are not express warranties and do not form the basis of any bargain between the parties but are merely IEC's opinion or commendation of its products. Manufacturer's standard limited warranty applies.



1/2", 3/4" Union

Valve Information	
<b>Manufacturer</b>	Nibco
<b>Type, Model</b>	733, B255400 (1/2") B255500 (3/4")
<b>Customer Furnished</b>	No
<b>IEC Furnished</b>	Yes
<b>Factory Installed</b>	Yes



Materials		Specifications	
<b>Tube &amp; Pipe Fitting</b>	Cast Copper	<b>Outside Diameter (in)</b>	2-5/8"
		<b>Temp. Range (F)</b>	-20° - 400°
		<b>Max Pressure</b>	336 psi @ 100°F
		<b>Weight (lbs)</b>	0.306
<b>Pipe Fitting Connection Type</b>	C x C		
<b>Size</b>	1/2", 3/4"		
<b>Sweat</b>	Yes		
<b>Threaded</b>	No		

International Environmental Corporation (IEC) © works continually to improve its products. As a result, the design and specifications of each product may be changed without notice and may not be as described herein. Please contact IEC for information regarding current design and product specifications. Statements and other information contained herein are not express warranties and do not form the basis of any bargain between the parties but are merely IEC's opinion or commendation of its products. Manufacturer's standard limited warranty applies.





# 1/2", 3/4" AutoFlow Fixed Flow Control

Valve Information	
<b>Manufacturer</b>	Hays
<b>Type</b>	2517
<b>Customer Furnished</b>	No
<b>IEC Furnished</b>	Yes
<b>Factory Packaged for Field Mounting</b>	Yes

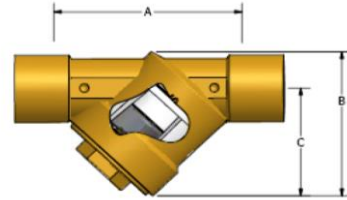

Materials		Dimensions	
<b>Body</b>	Brass	<b>A (in.)</b>	2.04 (1/2") 2.36 (3/4")
<b>O-Rings</b>	EPDM	<b>B (in.)</b>	2.12 (1/2") 2.11 (3/4")
<b>Diaphragm</b>	EPDM	<b>C (in.)</b>	1.58 (1/2", 3/4")
<b>Orifice</b>	Polyphenylsulfone		
<b>End Cap</b>	Brass		
<b>Size</b>	1/2", 3/4"		
<b>Connection</b>	Female Sweat		
<b>Flow Range</b>	0.50-5.00 GPM		
<b>Pressure Differential</b>	2-80 PSID up to 5.00GPM		
<b>Operating Temperature</b>	32°F – 225°F		
<b>Operating Pressure</b>	600 PSIG		

International Environmental Corporation (IEC) © works continually to improve its products. As a result, the design and specifications of each product may be changed without notice and may not be as described herein. Please contact IEC for information regarding current design and product specifications. Statements and other information contained herein are not express warranties and do not form the basis of any bargain between the parties but are merely IEC's opinion or commendation of its products. Manufacturer's standard limited warranty applies.



## 1/4" MNPT P-T Ports

Valve Information	
<b>Manufacturer</b>	Nexus
<b>Type</b>	PT-025
<b>Customer Furnished</b>	No
<b>IEC Furnished</b>	Yes
<b>Factory Packaged for Field Mounting</b>	Yes

CAP w/ O'RING AVAILABLE IN GREEN, RED or NO O'Ring (CONSULT FACTORY)

Materials		Dimensions – See image above	
<b>Body</b>	DZR Brass	<b>A (in)</b>	1.45
<b>Cap</b>	DZR Brass	<b>B (in)</b>	1/4" MNPT
<b>Plug Seal</b>	Nordel		
<b>Thread Sealant</b>	Loctite 516	<b>Weight (lbs.)</b>	0.06
<b>Size</b>	1/2", 3/4"	<b>Max Operating Pressure (psig)</b>	1000
<b>Sweat</b>	Yes	<b>Max Operating Temperature (°F)</b>	325
<b>Threaded</b>	No (Final Assy will be sweat connection)		

International Environmental Corporation (IEC) © works continually to improve its products. As a result, the design and specifications of each product may be changed without notice and may not be as described herein. Please contact IEC for information regarding current design and product specifications. Statements and other information contained herein are not express warranties and do not form the basis of any bargain between the parties but are merely IEC's opinion or commendation of its products. Manufacturer's standard limited warranty applies.



## 1/2", 3/4" Y-Strainer with Blowdown

Valve Information	
<b>Manufacturer</b>	Nexus
<b>Type</b>	Ultra YSS™
<b>Customer Furnished</b>	No
<b>IEC Furnished</b>	Yes
<b>Factory Packaged for Field Mounting</b>	Yes

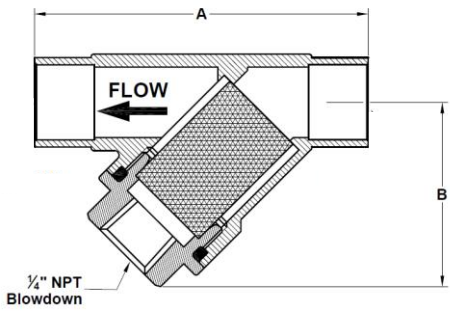

Materials		Dimensions	
<b>Body</b>	Forged Brass ASTMB283	<b>A(in)</b>	2.80 (1/2") 3.82" (3/4")
<b>Cap Seal</b>	Viton / EPDM O-Ring	<b>B(in)</b>	1.80 (1/2") 2.50 (3/4")
<b>Filter Screen</b>	20 Mesh 304 Stainless Steel	<b>Weight (lbs.)</b>	0.32 (1/2") 0.70 (3/4")
<b>Strainer Cap</b>	Forged Brass ASTM B283	<b>Filter Area (sq. in.)</b>	2.70 (1/2") 7.40 (3/4")
<b>O-Ring Seals</b>	600 WOG, 325F		
<b>Blowdown</b>	Y	<b>Cv<sup>1</sup></b>	5.5 (1/2") 9.0 (3/4")
<b>Size</b>	1/2", 3/4"		
<b>Sweat</b>	Yes		
<b>Threaded</b>	No		

International Environmental Corporation (IEC) © works continually to improve its products. As a result, the design and specifications of each product may be changed without notice and may not be as described herein. Please contact IEC for information regarding current design and product specifications. Statements and other information contained herein are not express warranties and do not form the basis of any bargain between the parties but are merely IEC's opinion or commendation of its products. Manufacturer's standard limited warranty applies.



# Programmable Fan Coil Thermostat

Part Numbers: E055-71520317 with logo  
E055-71520319 without logo

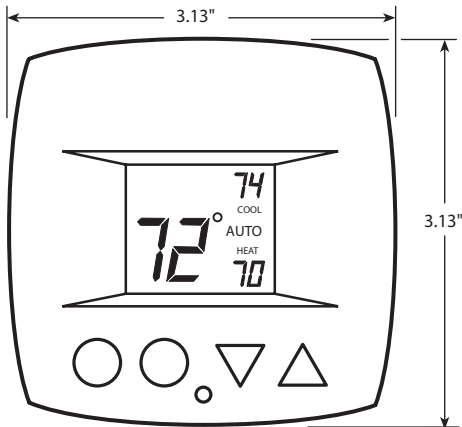

## Features:

- 2- or 4-pipe operation
- 3 speed fan operation
- Single or dual set point option
- Large Thermoglow™ display
- 7-day programmable with 4 time periods per day
- Copy day command
- Auto-changeover
- Neverlost™ memory
- Heating and cooling indicator light
- Zone temperature control to 1-degree accuracy
- Keypad lockout
- Dry contact for normally open or normally closed option
- Outside air temperature display
- Celsius or Fahrenheit display
- Display blanking feature
- Adjustable deadband
- Title 24 compliance

## Specifications:

<b>Recommended Wiring</b>	22 AWG (36 ft max) 18 AWG (100 ft max)
<b>Operating Temperature F (C)</b>	41 to 104 (5 to 40)
<b>Storage Temperature F (C)</b>	-40 to 135 (-40 to 57)
<b>Operating Relative Humidity</b>	0 to 95% (non-condensing)
<b>Dimensions (In.)</b>	3.13 x 3.13 x 1.13
<b>Power</b>	5 va at 24 vac, 60 Hz

AWG - American Wire Gauge

## Features and Benefits:

IEC's line of commercial programmable low-voltage fan coil thermostats maintain room temperatures by controlling the operation of 2- or 4-pipe fan coil systems. These thermostats have separate heating and cooling set points with auto-changeover as standard features.

The thermostat has 3-speed fan operation capability and the option to show single or dual set points. Programming of up to 3 occupied and 1 unoccupied time/temperature settings is allowed. Batteries are not required. During power interruption, the internal memory stores schedules for an unlimited time while the clock will continue to run for at least 48 hours.

## Year-round comfort is assured:

One-degree control accuracy precisely monitors the desired space temperature to within 1 degree of user set point by using a solid-state, laser-trimmed sensor.

Heating and cooling LED operation glows red when unit is in the Heating mode and green when unit is in the Cooling mode.

Neverlost™ memory protection on the thermostat eliminates the need to reconfigure the thermostat after power outages so your configurations will remain intact indefinitely.

IEC's warranty ensures peace of mind.

## Easy programming for quick operation:

The backlit Thermoglow™ display is large and easy to read. The backlight feature can be configured for either button activation or continuous lighting. Also simple adjustments will display room temperatures in either Celsius or Fahrenheit, time of day, or temperature and set points.

Four time periods per day allow flexibility to create schedules for every application. Start and stop times along with heating and cooling set points are easily entered into the schedule.

## Agency Approvals:

Complies with FCC Part 15 rules. Thermostat does not cause harmful interference and accepts all interference received.

UL and UL, Canada approval. These thermostats are considered low voltage devices by UL and do not require UL approval. As an added assurance to the quality of the thermostats, these thermostats are UL listed.

Title 24 compliance. Meets specified requirements of programming capability for all California commercial installations.





## **Fan Coil Unit Programmable Thermostat Guide Specifications**

### **System Description:**

24 V programmable, 2- or 4-pipe (or electric heat), room fan coil unit controller with digital display.

### **Quality Assurance:**

Unit shall be tested and certified in accordance with FCC Part 15 for RF interference, is UL and UL Canada certified, meets European Community standards and meets specified programming capability requirements for all California commercial installations.

### **Delivery, Storage and Handling:**

Each unit shall be individually packaged from point of manufacture and shall be handled and stored in accordance with manufacturer's instructions.

### **Standard Equipment Features:**

#### **General:**

The low-voltage, 7-day programmable digital thermostat shall be capable of maintaining room temperature by controlling operation of an HVAC system.

#### **Mounting:**

Thermostat shall be wall-mounted, surface mounted, or unit mounted.

#### **Standard Features:**

Thermostat shall allow separate heating and cooling set points and auto-changeover as standard.

#### **Configurations:**

The thermostat shall accept several different equipment configurations/applications including single-stage heating and cooling, two stages of heating and cooling, or electric heating and hydronic systems.

#### **Power:**

Batteries shall not be required. During power interruption, the internal memory shall store user-defined default settings as well as the user's comfort programming and configuration. Clock and day of the week settings shall be retained for a minimum of 48 hours.

#### **Display:**

The backlit thermostat display shall be large and easy to read with a single adjustment to show temperature in Celsius or Fahrenheit.

#### **Settings:**

- Thermostat shall have a solid-state, laser-trimmed sensor with one-degree control accuracy to precisely control the desired space temperature to within 1 degree of user set point.
- The thermostat shall have an auto-changeover with adjustable deadband to enable the user to choose separate heating and cooling set points (35°F to 99°F). This adjustable deadband shall be configurable to user's specifications (from 1° to 6°F) and in cycles per hour (2 to 6).

#### **Other Features:**

- For safety purposes, the front panel buttons shall be capable of being disabled to prevent unauthorized use of the thermostat.

#### **Optional Features:**

- Exact Fit® locking cover installed with optional standard or special tools to prevent unauthorized users from accessing the front panel buttons.
- Mounting plate and cover plate to allow thermostat to be mounted directly to wall or to standard 2" x 4" or 4" x 4" junction box.

### **Schedules:**

- The thermostat shall have a 5+1+1 day clock (Monday-Friday, Saturday, Sunday) provided with 3 occupied and 1 unoccupied time periods for scheduling of heating and cooling set points.
- A minimum of four-hour setback override shall return the system to occupied set points if heating or cooling is needed during unoccupied hours. The override shall be adjustable in 30-minute increments and return the system to unoccupied mode when override expires.

### **Sequence of Operation**

#### **Four-Pipe Operation:**

- The Mode button selects the operating mode of the thermostat. If Off is selected, the thermostat will not enter Heating or Cooling mode. If Heat is selected, the thermostat will only enter Heating mode (if the room temperature is below the heating set point). If Cool is selected, the thermostat will only enter Cooling mode (if the room temperature is above the cooling set point). If Auto is selected, the thermostat will enter Heating or Cooling mode based on the room's temperature and the heating and cooling set points.

#### **Two-Pipe Operation:**

- Heat Only – When the thermostat is configured for Heat Only operation, only the Heat and Off modes can be selected.
- Cool Only – When the thermostat is configured for Cool Only operation, only the Cool and Off modes can be selected.
- Heat/Cool with Changeover Sensor – When the thermostat is configured for operation with a changeover sensor, all the modes are available for operation. If the water temperature is changed during the year, the thermostat will automatically lock out the incorrect mode. Heat or Cool modes may not be available, depending on water temperature.

#### **Total or Auxiliary Electric Heat:**

The Mode button selects the operating mode of the thermostat. If Off is selected, the thermostat will not enter Heating or Cooling mode. If Heat is selected, the thermostat will only enter Heating mode (if room temperature is below the heating set point). For total electric heat, a call for heat will enable the electric heater. For auxiliary electric heat, a call for heat will either enable the electric heater (if chilled water is in the coil), or open the coil valve (if hot water is in the coil). If Cool is selected, the thermostat will only enter Cooling mode (if room temperature is above the cooling set point and chilled water is in the coil). If Auto is selected, the thermostat will enter Heating or Cooling mode based on the room's temperature and the heating and cooling set points.

#### **Auto Changeover:**

When the thermostat mode is set to Auto, the thermostat will provide automatic changeover from Heating or Cooling mode and Cooling to Heating mode when required. The thermostat will automatically switch to maintain the desired temperature setting. The thermostat does not need to be manually changed from heating to cooling or cooling to heating operation.

#### **Fan Operation:**

When only the Fan is in "Auto" mode, it will run continuously (unless thermostat mode is set to Off or thermostat is in unoccupied mode and heating or cooling are not active). The thermostat will increase or decrease the fan speed based on load conditions. Fan operation may also be set to always run at Low, Medium, or High speeds.

#### **Dry Contact Switch/External Control:**

- A dry contact switch is provided to allow an external device to force the thermostat into the unoccupied set points configured by the installer. When the thermostat is forced into unoccupied set points via the dry contact closure, the unoccupied icon will blink each second.
- In some applications, the dry contact switch may be configured to disable the fan, heating, and cooling from a condensate switch. If the condensate switch activates the dry contact, the fan coil unit will be deactivated instead of controlling to the unoccupied set points.

#### **Outside Sensor:**

Thermostat shall display outside temperature (if optional outdoor sensor is wired to thermostat).