

*Quality People. Building Solutions.*

Comfort Systems USA (Arkansas), Inc.  
P.O. Box 16620  
Little Rock, AR 72231  
Phone 501-834-3320  
Fax 501-834-5416

**Date:** 12/1/2022  
**Return Request:** 12/11/2022  
**Project:** New Dormitories – Bldg. 6  
**Supplier:** Little Rock Winnelson  
**Manufacturer:** Armstrong  
**Submittal:** Domestic Water Pumps  
**Submittal Number:** 22 11 23-01  
**Drawing # and Installation:** Plumbing Drawings

**ARCHITECT**

Stocks Mann Architects  
401 W. Capitol, Suite 402  
Little Rock, AR 72201  
501-370-9207

**ENGINEER**

Bernhard TME  
1 Allied Drive #2600, Building 2  
Little Rock, AR 72202  
501-666-6776

**GENERAL CONTRACTOR**

Alessi Keyes Construction  
10623 Maumelle Blvd.  
N. Little Rock, AR 72113  
501-225-6699

**MECHANICAL SUBCONTRACTOR**

Comfort Systems USA (Arkansas), Inc.  
9924 Landers Rd.  
N. Little Rock, AR 72117  
501-834-3320

Notes:

**CSUSA PROJECT NO.**

**22-102**

[jon@comfortar.com](mailto:jon@comfortar.com)

**ALESSI KEYES CONSTRUCTION**  
**REVIEWED FOR GENERAL COMPLIANCE**  
**WITH CONTRACT DOCUMENTS**

**Charley Dawson 1/18/2023**

# CP-1 CIRCULATOR PUMP

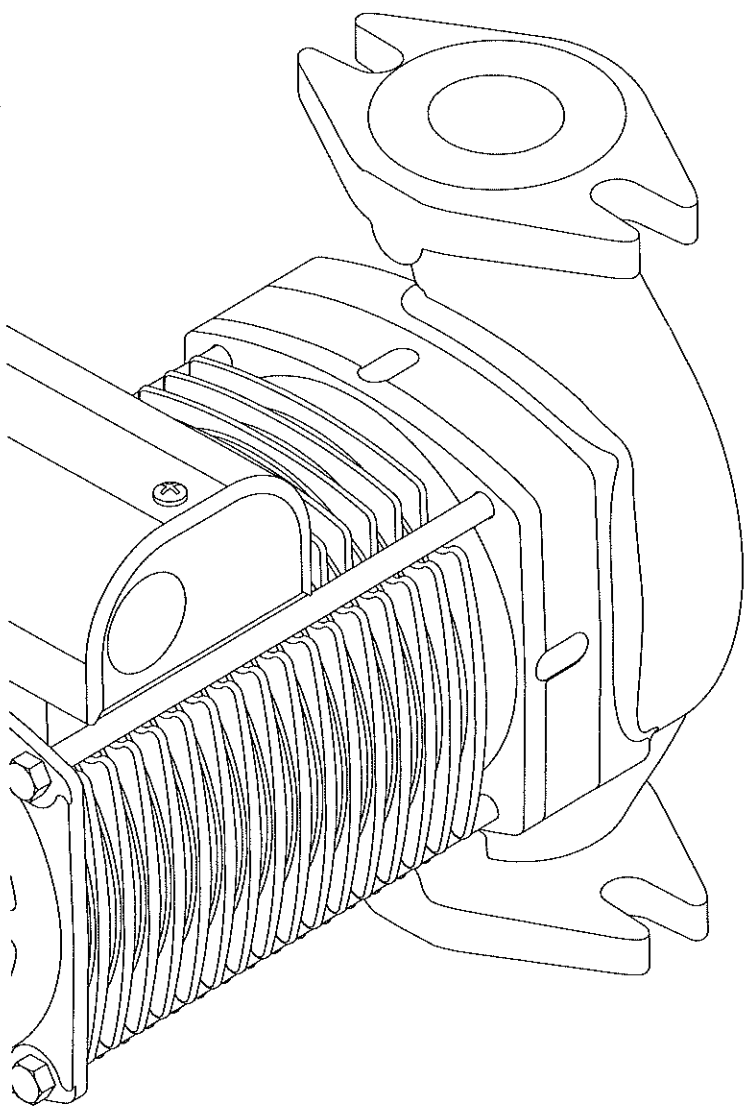

# **E.2 Series**

## **High efficiency circulator**

---

### **Installation and operating instructions**

File No: 10.84  
Date: JULY 04, 2018  
Supersedes: 10.84  
Date: JANUARY 25, 2018

1

2

3

4

## CONTENTS

1.0	Operating limits	4
2.0	Electrical wiring	4
3.0	Start up	5
4.0	Preventive maintenance - inspection	5
5.0	Pump replacement in an existing installation	6
5.1	Complete pump	6
5.2	Motor end only	6
6.0	Mechanical seal replacement	6
7.0	ε.2 product family specifications	8

## READ CAREFULLY BEFORE INSTALLING & OPERATING THE CIRCULATOR

**INSTALLER:** PLEASE LEAVE THIS MANUAL FOR THE OWNER'S USE

You are about to install an E.2 series circulator - a high-efficiency pump from Armstrong. E.2 series circulators are designed for heating and cooling in hydronic, geothermal or solar systems and circulating water, ethylene or propylene glycol/water solutions. For pumping domestic (potable) water, Armstrong recommends the use of circulators with bronze, or stainless steel body construction.

The E.2 series circulators are extremely efficient and quiet. They utilize a state of the art permanently lubricated bearing system designed for many years of trouble-free operation. They feature a permanent-split capacitor motor with thermal protection.

### 1.0 OPERATING LIMITS

**Maximum operating pressure:**

150 psi (1034 kPa)

**Maximum operating temperature:**

All standard models 230°F (110°C)

**Minimum operating temperature:**

All standard models 32°F (0°C)

**Electrical rating:**

For models with 1/8 hp motors (100W): 120 v, 1 phase, 60 Hz or 208/240 v, 1 phase, 60 Hz, or 220-240v, 50Hz

For models with 3/8 hp motors (300W): 120 v, 1 phase, 60 Hz or 208/240/277 v, 1 phase, 60 Hz, or 220-240v, 50Hz

When unpacking the circulator, inspect for any damage that may have occurred during transit. Check for loose, missing or damaged parts.

### THIS PUMP IS FOR INDOOR USE ONLY

Before installing the circulator, proper installation practice recommends a thorough flush of the hydronic system, ensuring removal of all foreign materials.

This pump should be installed in a well lit location with good access.

Installation personnel must be qualified for the task.

All personnel performing installation must wear appropriate personal protective equipment

### WARNING



Mount with motor shaft horizontal and terminal box above centerline (CL) only!

The circulator is supplied for up-discharge.

**DIAGRAM 1:** Installation Orientation

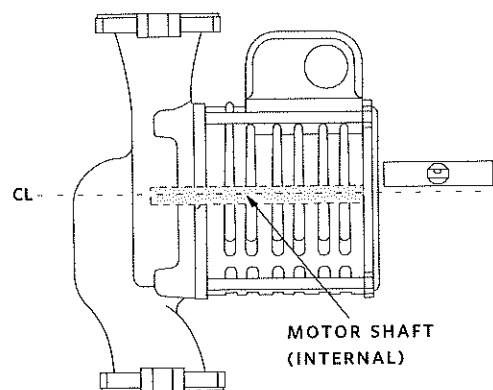

For alternate discharge orientation:

- 1 Loosen the four motor mounting bolts
- 2 Rotate the volute to match piping orientation
- 3 Observe flow direction arrow on volute
- 4 Ensure volute gasket is properly seated
- 5 Retighten mounting bolts evenly to 5 lb/ft (6.7 N/m)
- 6 Ensure the impeller spins freely

### 2.0 ELECTRICAL WIRING



The electrical wiring must be installed in strict accordance with the Canadian Electrical Code (Canada) or the U.S. National Electrical Code (USA), or BS7671 (Europe) as well as local codes and regulations.

- 1 Electrical installation should be conducted by a qualified electrician. Installers should be equipped with proper personal protective equipment.
- 2 The motors of E.2 series circulators are designed for 1 phase, 60 Hz, 120 v 60 Hz, 240 v 60 Hz, 220-240 50 Hz service only. (Please refer to the rating label on the circulator's terminal box to determine the correct voltage.)
- 3 Always make sure the electric power is disconnected and locked out before wiring the circulator.
- 4 To wire, loosen the screw from the terminal box cover and remove the screw and cover.
- 5 Install the appropriate size conduit end to one of the holes on either side of the terminal box.

6 For 120 v models: Referring to **DIAGRAM 2** below, connect the black, hot, (L) and white, neutral, (N) leads of the supply wire to the black and white motor leads respectively inside the terminal box. Connect the ground wire to any one of the four green ground screws inside of the terminal box (use a minimum 18 AWG wire size).

For 208/240/277 v models: Referring to **DIAGRAM 3** below, connect the black (L1) and blue (L2) leads of the supply wire to the black and blue motor leads respectively inside the terminal box. Connect the ground wire to any one of the four green ground screws inside of the terminal box (use a minimum 18 AWG wire size).

**NOTE:** For any voltage the brown and yellow wires are hard wired in and should **not** be touched they are for the capacitor only and can stop the motor from running.

**DIAGRAM 2** 120 v installations

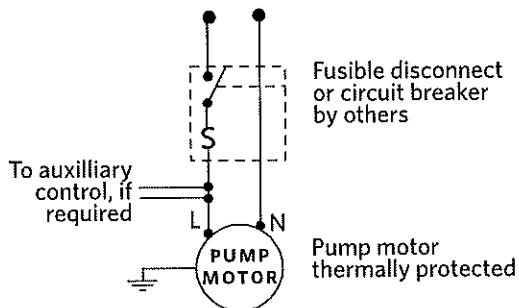

Typical wiring diagram for  
single phase, 120 v, 60 Hz power source

**DIAGRAM 3** 208/240/277 v installations

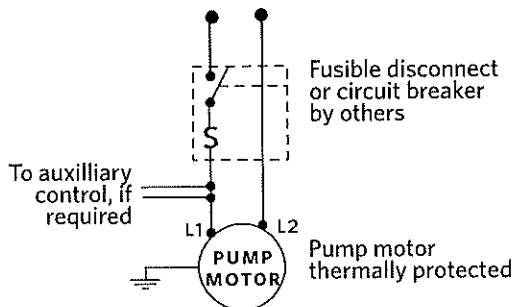

Typical wiring diagram for  
A single phase, 240 v, 60 Hz power source  
B three phase, 208/277 v, 60 Hz power source

**DIAGRAM 4** 230 v installations

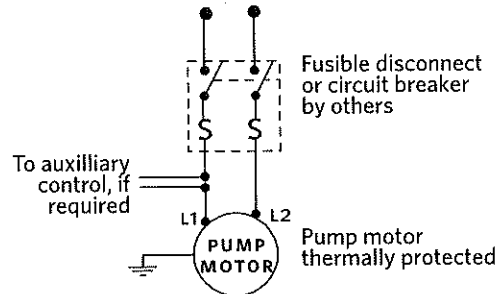

Typical wiring diagram for  
single phase, 230 v, 50 Hz power source

7 Replace the terminal box cover.

The motor is thermally protected for your safety so thermal overload protection is not necessary. All that is required is a fused plug or circuit breaker in the power line for short circuit protection.

Electrical information can be found on the nameplate of the motor.

### 3.0 START UP

- 1 Before starting up the circulator, proper installation practice recommends a thorough flush and draining of the hydronic system, ensuring removal of all foreign materials. Fill the system with clean water or glycol solution before starting.
- 2 Air must be completely vented from the system before starting up the circulator. **If the system is not completely vented of air and the circulator is allowed to run dry, the mechanical seal will be damaged.**
- 3 When the system has been completely filled and vented, only then can the pump be started.

### 4.0 PREVENTIVE MAINTENANCE - INSPECTION

E.2 series circulators are fitted with permanently lubricated ball bearings and **do not** require lubrication.

Although Armstrong long-life circulators are designed to provide years of worry-free service, it is good maintenance practice to inspect the entire hydronic system periodically - including the E.2 series circulator - for potential problems. If there is any evidence of leakage or damage, repair or replace the pump.

Disconnect and lockout the power before servicing.

## 5.0 PUMP REPLACEMENT IN AN EXISTING INSTALLATION

### 5.1 COMPLETE PUMP

- 1 Ensure that electric power is disconnected and locked out. Loosen the screw from the terminal box cover and remove the cover. Disconnect the supply wires from the circulator only, leaving the capacitor wires connected.



All servicing personnel should be equipped with proper personal protective equipment.

- 2 If valves have been installed, on the suction and discharge sides of the pump, close them before attempting to remove the circulator from the volute. If no valves have been installed it may be necessary to drain the system.



Allow water to cool to 100°F (40°C) before draining the system. It is best to leave the drain valve open while working on the system.

- 3 To relieve any residual pressure which may be present in the pump body, loosen the flange bolts and gently move the pump body back and forth to allow the pressurized water to escape.

**NOTE:** Place a pan under the pump to collect the drain water.

- 4 If the entire volute is needed to be removed, then remove the flange bolts and nuts. The entire circulator can then be removed from the piping system.
- 5 Install the E.2 series circulator where there will be sufficient room for inspection and service. It is recommended that isolation valves be installed on both the suction and discharge sides of the circulator for future servicing. This eliminates the need for draining the system when working on the circulator (for example, when replacing the mechanical seal).
- 6 Install suction and discharge flanges on the pipe ends. The use of Teflon tape sealer or a high quality thread sealant is recommended.
- 7 Pipe strain can be minimized by the use of pipe hangers near the pump, positioned to support the suction and discharge piping.

To wire the E.2 series circulator, follow steps C through G in the Electrical Wiring section above, noting that electrical supply and grounding wires must be rated for at least 194°F (90°C).

### 5.2 MOTOR END ONLY

- 1 Turn off the pump leaving it installed in the line .
- 2 Ensure electrical power is disconnected and locked out .
- 3 Close the water supply at the points closest to the pump's inlet and outlet .

- 4 For safety, allow water to cool to 100°F (40°C) before draining the system. It is best to leave the drain valve open while working on the system.
- 5 Bleed the water pressure from the pump.
- 6 Place a pan under the pump to collect the drain water.
- 7 While holding the motor body, loosen the four bolts that attach the motor to the pump casing (volute). Start with the two bottom bolts first and remove them, then slowly loosen the top two bolts. Allow the water to drain from the bottom of the pump. When the water has finished draining, remove the two top bolts. Remove the motor straight out from the volute being careful of its attached impeller. The motor is heavy, do not drop it.
- 8 Install new casing gasket .
- 9 Install new motor end (with impeller and seal kit).
- 10 Tighten four motor end bolts in a crisscross pattern and tighten evenly to 60 in/lbs.
- 11 Open isolation flanges or fill the system with water before starting circulator.
- 12 To wire the E.2 series circulator, follow steps C through G in the Electrical Wiring section above, noting that electrical supply and grounding wires must be rated for at least 194°F (90°C).

## 6.0 MECHANICAL SEAL REPLACEMENT

- 1 Follow steps 1 through 4 in section **Existing pump removal from system piping**.
- 2 While holding the motor body, remove the bottom two bolts that attach the motor to the pump casing (volute), then slowly loosen the top two bolts. Allow the water to drain from the bottom of the pump. When the water has finished draining, remove the two top bolts. Remove the motor straight out from the volute being careful of the attached impeller.



### Handle with care

The motor is heavy, and possibly hot,  
**DO NOT** drop it!

- 3 While holding the rotor very tightly by hand or a gloved hand only, unscrew the impeller nut off the motor shaft by turning it clockwise (i.e. opposite to most bolts and nuts). Place the motor on its back, with the shaft up.
- 4 Remove the rotary part of the mechanical seal by gently pulling it off the shaft. If it is too tight use two small flat bladed screwdrivers to gently pry it off the shaft by placing the flat side of the blades onto opposite sides of the mechanical seal.



- 5 Remove the face plate from the motor by gently prying it off of the motor housing extension, and carefully pulling it straight up, avoiding any shaft contact.
- 6 Remove the stationary part of the seal by gently prying it off the steel faceplate.
- 7 Remove any corrosion present on the stainless steel motor shaft and face plate (especially the seal seat area) with a non-metallic brush or scrub pad. Do not use a wire brush or steel wool.
- 8 Remove any dust created during step #7 above and put a few drops of non-petroleum lubricant around the face plate where the stationary seat is to be installed.
- 9 Install the new stationary seal seat into the faceplate by firmly pressing it down until it bottoms. The disk should be clean. If needed, wipe it with alcohol and a soft lint free cloth.
- 10 Replace the faceplate on the motor housing extension, being careful to avoid shaft contact. This may need to be gently tapped down until tight to the housing. Be sure to check that the stainless steel plate is flush to the extender plate face.
- 11 Install the special **installation tool** (item #180202-095) on the top of the shaft making sure it is tight to the flat base of the impeller to protect the seal from sharp edges during seal installation.
- 12 Apply a liberal amount of non-petroleum based lubricant on the outside of the special plastic **installation tool**.
- 13 Wipe any excess lubricant off of the stationary silicon carbide seal face with a lint free cloth and alcohol to ensure the surface is clean.
- 14 Install the new rotating seal element and spring assembly by gently pushing it (graphite ring first) over the **installation tool** and onto the shaft until the graphite ring presses tightly against the stationary seal seat. The seal spring may be compressed slightly.
- 15 Remove the **installation tool** from the shaft.
- 16 Install the impeller keeping the inlet end up. Make sure to align the flats to the shaft flats and push the impeller down tightly to the seal.
- 17 Place 2-3 drops of medium strength thread locker liquid on the nut threads.
- 18 Install the special left hand thread nut on the motor shaft. While holding the motor rotor in place as in step 3, thread the impeller nut on to the shaft in a counter-clockwise direction and tighten the nut to approximately 6ft-lbs (8.1Nm).
- 19 If the impeller will not spin freely contact Armstrong Technical Support at 1-416-755-2291 or email [techsupport@armlink.com](mailto:techsupport@armlink.com).
- 20 Ensure the gasket is properly seated in the pump casing (volute) gasket groove. Holding the motor body, insert the impeller straight into the volute. Verify the gasket was not dislodged during insertion, and is still seated properly. Hold the motor body steady while fastening the four bolts that attach the motor to the pump casing (volute). Tighten evenly and diagonally. There should be a small, even gap of about 0.02" (0.5 mm) between the motor flange and the pump casing (volute).
- 21 Follow the **START UP** instructions (File no. 10.84) and check for leaks.

**DIAGRAM 5** Internal Assembly (Exploded view)

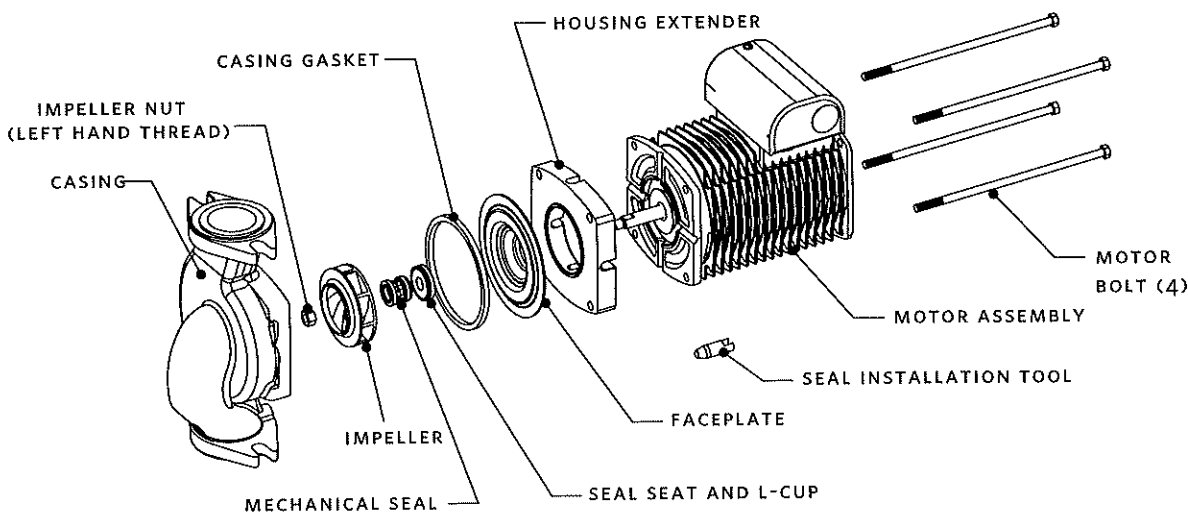

## 7.0 PRODUCT FAMILY SPECIFICATION

### 50 HZ E.2 SERIES MODELS

#### Hydraulic data

MODEL	E7.2/ E7.2B	E9.2/ E9.2B	E12.2/ E12.2B	E14.2/ E14.2B	E22.2/ E22.2B	E33.2/ E33.2B
Nominal Hydr. Power (watts)	105	105	252	252	252	252
Max Flow (L/sec.)	1.9	1.8	2.7	2.8	4.9	7.9
Max Head (m)	5.3	7.7	10.6	11.4	8.7	6.3
Max. Efficiency (BEP%)	22.5	26.4	31.2	32.4	40.7	42.1
Max. Fluid Temperature	110°C (All models)					
Max. Ambient Temperature	50°C (All models)					
Max. Working Pressure	1034 kPa (All models)					

#### Electrical (motor) data

MODEL	E7.2/E7.2B	E9.2/E9.2B	E12.2/E12.2B	E14.2/E14.2B	E22.2/E22.2B	E33.2/E33.2B
Nominal input voltage range @50 HZ.	220-240VAC	220-240VAC	220-240VAC	220-240VAC	220-240VAC	220-240VAC
Full load current draw @50 HZ. (AC Amperes)	0.80	0.90	1.7	1.8	2.3	2.3
Speed @ max flow (RPM)	2892	2855	2885	2868	2780	2760
Max. Efficiency (BEP%)	22.5	26.4	31.2	32.4	40.7	42.1

TORONTO  
+1 416 755 2291

BUFFALO  
+1 716 693 8813

BIRMINGHAM  
+44 (0) 8444 145 145

MANCHESTER  
+44 (0) 8444 145 145

BANGALORE  
+91 (0) 80 4906 3555

SHANGHAI  
+86 (0) 21 5237 0909

SÃO PAULO  
+55 11 4785 1330

## ET-1 EXPANSION TANK

# Model WTTA

ASME Thermal Expansion Tank



## □ Installation □ Maintenance Instructions

### INSTALLATION MAINTENANCE INSTRUCTIONS

Connect the thermal expansion tank to be cold water supply line between the backflow preventer or check valve and the water heater. This location is preferred for two reasons: a cool bladder will last longer, and the air charge will not thermally expand. Piping Detail below illustrates the suggested configurations.

#### Checking and charging instructions

1. Close the isolation valve.
2. Slowly open the drain valve. Caution must be taken when opening the drain valve as it is under system pressure. The drain valve must remain open while checking and adjusting the tank pre-charge pressure
3. Check the air charge pressure using an accurate pressure gauge. The tank has a standard tire fitting (.302" - 32 valve). There are special pressure gauges fitted with the required air chuck available or a good quality tire air gauge may be used.
4. Adjust air charge pressure if required. The air charge pressure should be equal to the supply water pressure.

Air may be released from the tank by depressing the stem of the tire fitting until supply water pressure is equaled. There are a number of ways to get more air pressure in the tank.

**Manual pump.** A common bicycle air pump can be used. This is practical only when a small amount of additional air is required or if your in great shape and have several hours to kill.

**Oil-free air compressor.** A portable oil-free air compressor can be used. Most portable compressors can deliver 40-60 psig air, this may not be adequate.

**Gas station fill-up.** Almost all gas stations have air available at over 100 psig.

**Bottled nitrogen.** Rental tanks are inexpensive and 70 cu/ft, at 2000 psig, sizes are available. This size will fill even the largest thermal expansion tank. Nitrogen is not required and there is usually an extra cost for the required fitting.

5. Close the drain valve.
6. Open the isolation (System) valve.

Check the air charge pressure at least once a year. Tanks can lose charge from a leaking air valve, through the bladder or diaphragm membrane, or from a loose fitting.

The Thermal trap shown on the ceiling-hung tank, as shown in the Piping Detail, prevents the tank from being heated due to convection.

#### SUGGESTED SPECIFICATIONS

Furnish and install a thermal expansion tank for hot potable water as shown on the drawings. The tank shall be: (choose one)

The tank shall have a stainless steel NPT system connection and a .302" charging connection. The contractor shall field adjust the pre-charge pressure to equal the cold water supply pressure. The final adjusted pre-charge pressure to equal the cold water supply pressure. The final adjusted pre-charge pressure shall be reported in writing to the engineer. A pressure reducing valve shall be installed if the cold water supply pressure exceeds 80 psig. An FDA approved heavy duty butyl bladder shall prevent the water from coming in contact with the tank shell. Diaphragm type tanks with a water side lining shall not be acceptable.

The tank shall be connected to the cold water supply line. This line is to be piped with a thermal trap and fitted with an isolation valve and drain valve to allow for periodic checking and adjusting of the pre-charge pressure.

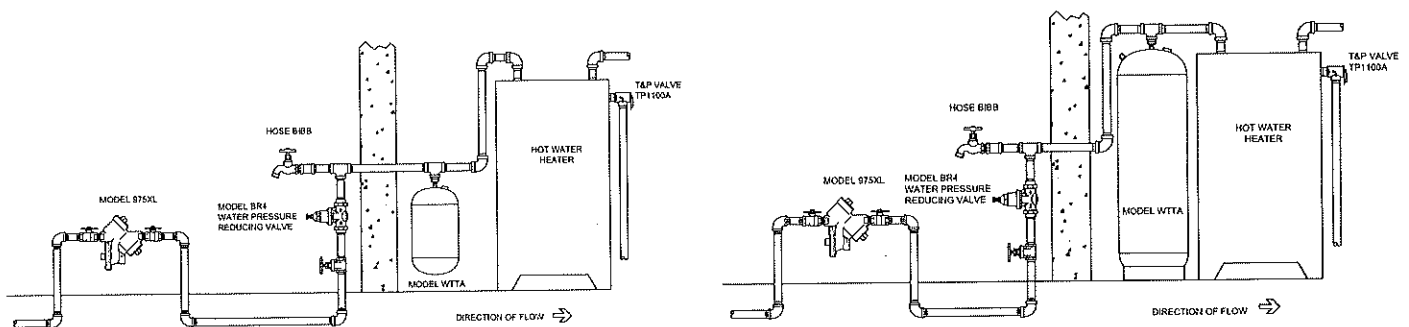

**WARRANTY:** ZURN WILKINS Valves are guaranteed against defects of material or workmanship when used for the services recommended. If in any recommended service, a defect develops due to material or workmanship, and the device is returned, freight prepaid, to ZURN WILKINS within 12 months from date of purchase, it will be repaired or replaced free of charge. ZURN-WILKINS' liability shall be limited to our agreement to repair or replace the valve only.

⚠ **WARNING:** Cancer and Reproductive Harm - [www.P65Warnings.ca.gov](http://www.P65Warnings.ca.gov)  
⚠ **ADVERTENCIA:** Cáncer y daño reproductivo - [www.P65Warnings.ca.gov](http://www.P65Warnings.ca.gov)  
⚠ **AVERTISSEMENT:** Cancer et néfastes sur la reproduction - [www.P65Warnings.ca.gov](http://www.P65Warnings.ca.gov)



ISWTTA (REV. B 6/17)

1747 Commerce Way, Paso Robles, CA 93446 Phone: 855-663-9876, Fax: 805-238-5766

ZURN WILKINS

[www.zurn.com](http://www.zurn.com)

# Transmittal

PROJECT: New Dormitories - Phase 2, Bldg. 6  
Booneville Human Development Center  
Booneville, Arkansas

SMA PROJECT NO: 2002B

DATE: January 20, 2023

TO: Alessi Keyes Construction  
10623 Maumelle Blvd.  
North Little Rock, AR 72113

If enclosures are not as noted, please  
inform us immediately.

If checked below, please:

ATTN: Charley Dawson

Acknowledge receipt of enclosures.

Return enclosures to us.

WE TRANSMIT:

Herewith

Under separate cover

VIA:

Courier

Mail

E-mail

Overnight delivery

Fax

Other

FOR YOUR:

Approval/Action

Information

Use as requested

Review & comment

Use

Other

THE FOLLOWING:

Drawings

Specifications

Digital Files - PDF

Submittals

Proposal Request

Digital Files - Other

Change Order

Samples

Other

COPIES	DATE	REV. NO.	DESCRIPTION	ACTION CODE
1	1/20/2023		Domestic Water Pumps	A

ACTION A. No action required

C. For signature and return to this office

E. See REMARKS below

CODE B. Action indicated on item transmitted

D. For signature and forwarding as noted below under REMARKS

REMARKS

COPIES TO:

(with enclosures)

Rex Morris, Morris AE

By: Trey Tassin

# Submittal Comment Sheet

**To:** Randy Stocks, Stocks-Mann Architects  
**From:** Rob Adams, BTME  
**Date:** January 20, 2023  
**Project:** Booneville HDC Building #6  
**Project #:** 01-20-0003  
**Ref:** 22 11 23 Domestic Water Pumps Submittal  
**Submitted By:** Alessi Keys Construction

APPROVED	<input type="checkbox"/>
REJECTED	<input type="checkbox"/>
REVISE AND RESUBMIT	<input type="checkbox"/>
REFER TO SUBMITTAL COMMENT SHEET	<input checked="" type="checkbox"/>

This review performed by Bernhard TME, LLC, is only for general conformance with the design concept of the project and general compliance with the information provided in the Contract Documents. Corrections or comments made on the submittal and/or shop drawings during this review do not relieve the Contractor from compliance with the requirements of the plans, specifications, and other contract documents. Approval of a specific item shall not indicate an approval of an assembly of which the item is a component. Contractor is responsible for the following: all quantities; configuration of components; dimensions to be confirmed and correlated at the jobsite; information that pertains solely to the fabrication process or to the means, methods, techniques, sequences, and procedures of construction; coordination of the work with that of all other trades; and, for performing all work in a safe and satisfactory manner.

**Bernhard TME**  
Engineering

DATE: 01/20/23 BY: R. Adams

Below find our response for the submittal received on Wednesday January 18, 2023.

1. CP-1

**APPROVED**

**- End of Submittal Comments -**

THIS REVIEW PERFORMED BY BERNHARD TME, LLC, IS ONLY FOR GENERAL CONFORMANCE WITH THE DESIGN CONCEPT OF THE PROJECT AND GENERAL COMPLIANCE WITH THE INFORMATION PROVIDED IN THE CONTRACT DOCUMENTS. CORRECTIONS OR COMMENTS MADE ON THE SUBMITTAL AND/OR SHOP DRAWINGS DURING THIS REVIEW DO NOT RELIEVE THE CONTRACTOR FROM COMPLIANCE WITH THE REQUIREMENTS OF THE PLANS, SPECIFICATIONS, AND OTHER CONTRACT DOCUMENTS. APPROVAL OF A SPECIFIC ITEM SHALL NOT INDICATE AN APPROVAL OF AN ASSEMBLY OF WHICH THE ITEM IS A COMPONENT. CONTRACTOR IS RESPONSIBLE FOR THE FOLLOWING: ALL QUANTITIES; CONFIGURATION OF COMPONENTS; DIMENSIONS TO BE CONFIRMED AND CORRELATED AT THE JOBSITE; INFORMATION THAT PERTAINS SOLELY TO THE FABRICATION PROCESS OR TO THE MEANS, METHODS, TECHNIQUES, SEQUENCES, AND PROCEDURES OF CONSTRUCTION; COORDINATION OF THE WORK WITH THAT OF ALL OTHER TRADES; AND, FOR PERFORMING ALL WORK IN A SAFE AND SATISFACTORY MANNER.



# SUBMITTAL SHEET

Alessi Keyes Construction Co.  
AKC-505 - Booneville HDC New Dorm

**Project:** AKC-505  
Booneville HDC New Dorm

**Spec Section Num:** 22 11 23  
**Submittal:** 22.10  
**Revision:** 0  
**Package:** Plumbing  
**Date:** 1/19/2023 UTC

**Submittal Title:** Domestic Water Pumps  
**Submittal Detail:**  
**Response Due By:** 2/8/2023 UTC

**Contractor:**  
Charley Dawson  
Alessi-Keyes Construction Co.

Contractor's Stamp

**Architect:**  
Trey Tassin  
Stocks-Mann Architects

Architect's Stamp

**Response:**  
**Comment:**

CP-1 CIRCULATOR PUMP  
ARMSTRONG E7.2B BRONZE CIRCULATOR  
PUMP WITH FLANGES 115V SP



## E.2 SERIES CIRCULATORS

### E7.2/E7.2B | SUBMITTAL

File No: 10.590  
 Date: JULY 25, 2018  
 Supersedes: 10.590  
 Date: JUNE 05, 2017

Job: \_\_\_\_\_ Representative: \_\_\_\_\_

Order no.: \_\_\_\_\_ Date: \_\_\_\_\_

Engineer: \_\_\_\_\_ Submitted by: \_\_\_\_\_ Date: \_\_\_\_\_

Contractor: \_\_\_\_\_ Approved by: \_\_\_\_\_ Date: \_\_\_\_\_

QUANTITY	TAG NO.	PART NUMBER	FLOW (USgpm)	HEAD (FEET)	VOLTAGE	PHASE	COMMENTS

#### TECHNICAL DATA

**Flow range:** 0 to 38.0 USgpm (0 to 2.4 L/s)  
**Head range:** 0 to 26.0 feet (0 to 7.9 m)  
**Max/Min fluid temp:** 230°F/32°F (110°C/ 0°C)  
**Max. Working pressure:** 150 psi (1034 kPa)

#### MATERIALS OF CONSTRUCTION

**Pump body:** Cast iron (closed systems)  
 Bronze (lead free for open systems)

**Face plate:** Stainless steel      **Shaft:** Stainless steel  
**Impeller:** 30% Glass-filled noryl      **Volute gasket:** EPDM  
**Bearings:** Permanently lubricated stainless steel  
**Seal:** Silicon carbide enviroseal c/w viton elastomer  
 All Bronze Circulators are NSF - 372 rated

#### PART NUMBER

	120V	240V
E7.2	182202-643	182202-671
E7.2B	182202-644	182202-672

#### E7.2/E7.2B ACCESSORIES

- ¾" Flange kits
- 1" Flange kits
- 1¼" Flange kits
- 1½" Flange kits
- Timer
- Aquastat

#### MOTOR DATA

<b>Voltage</b>	120V	208V	240V
<b>Full load amp draw</b>	1.5A	0.8A	0.8A

**Nominal power:** ½ hp (125W)      **Frequency:** 60 Hz  
**Motor type:** Two pole, Single phase      **Speed:** 3400 rpm

#### MOUNTING ORIENTATION FOR INDOOR USE ONLY

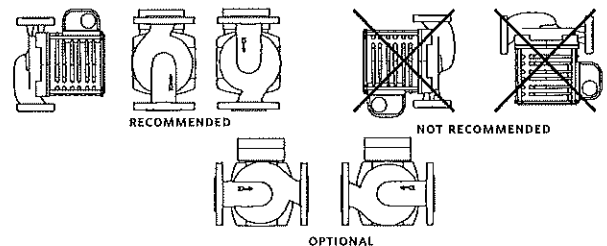

#### PERFORMANCE CURVE

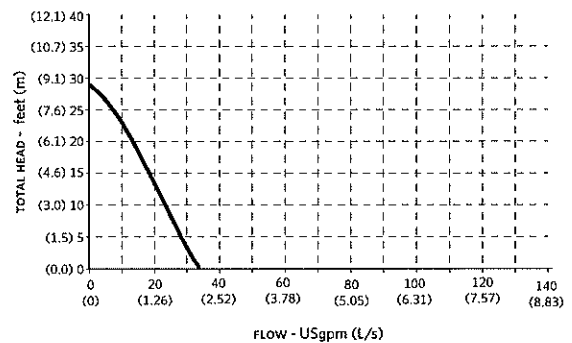

Performance curves are for reference only. Confirm current performance data with Armstrong ACE ONLINE selection software.

DIMENSIONS inches (mm)									SHIP. WEIGHT
MODEL	BODY	A	B	C	D	E	F	CONNECTION TYPE & SIZE	lbs (kgs)
E7.2	Cast iron	7.10 (180)	6.40 (164)	5.50 (140)	3.80 (97)	3.20 (81)	4.20 (107)	1.25" diameter 2-bolt flanges	13.1 (5.94)
E7.2B	Bronze	7.10 (180)	6.40 (164)	5.50 (140)	3.80 (97)	3.20 (81)	4.20 (107)	1.25" diameter 2-bolt flanges	13.3 (6.03)

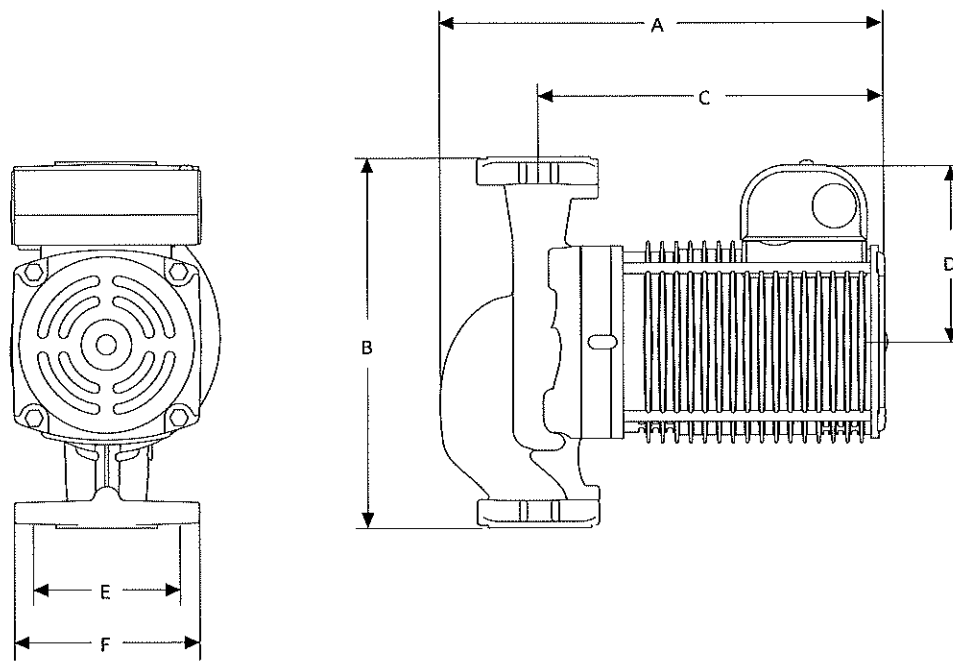

TORONTO  
+1 416 755 2291

BUFFALO  
+1 716 693 8813

BIRMINGHAM  
+44 (0) 8444 145 145

MANCHESTER  
+44 (0) 8444 145 145

BANGALORE  
+91 (0) 80 4906 3555

SHANGHAI  
+86 21 3756 6696

SÃO PAULO  
+55 11 4781 5500