

Quality People. Building Solutions.

Comfort Systems USA (Arkansas), Inc.
P.O. Box 16620
Little Rock, AR 72231
Phone 501-834-3320
Fax 501-834-5416

Date: 1/20/25

Project: UA Union Fit-Out
Supplier: Airetech Corp.
Manufacturer: LG
Submittal: Ductless Split Systems
Submittal Number: 238126-01
Spec Section: 23 81 26
Drawing #: Mechanical

ARCHITECT
Hufft

GENERAL CONTRACTOR
Clark Contractors

ENGINEER
BTME

**MECHANICAL
SUBCONTRACTOR**
Comfort Systems USA
(Arkansas), Inc.
116 Commercial Ave
Lowell, AR 72745
479-770-8992

Notes:

Ductless Split Systems O&M

**CSUSA PROJECT NO.
24-5009**

jzuber@comfortar.com

4806 Rixey Road
No. Little Rock, AR 72117



OPERATION AND MAINTENACE MANUAL

PROJECT: University of Arkansas – Union Fit Out

LOCATION: Fayetteville, AR

**MECHANICAL
CONTRACTOR:** Comfort Systems USA - AR

EQUIPMENT: LG Ductless Mini Splits (AC-1 thru 3)

SPECIFICATION: 23 81 26

DATE: January 20, 2025

Will McGehee
will@airetechcorp.com



SINGLE ZONE HIGH EFFICIENCY WALL MOUNTED INSTALLATION MANUAL



Models:

LS090HSV5

LS120HSV5

LS181HSV5

PROPRIETARY DATA NOTICE

This document, as well as all reports, illustrations, data, information, and other materials are the property of LG Electronics U.S.A., Inc., and are disclosed by LG Electronics U.S.A., Inc., only in confidence.

This document is for design purposes only.

Do not throw away, destroy, or lose this manual.

Please read carefully and store in a safe place for future reference.

Content familiarity required for proper installation.

The instructions included in this manual must be followed to prevent product malfunction, property damage, injury, or death to the user or other people. Incorrect operation due to ignoring any instructions will cause harm or damage. The level of seriousness is classified by the symbols described below.

A summary list of safety precautions begins on page 3.

Proper sizing and installation of equipment is critical to achieve optimal performance. Split system air conditioners and heat pumps (excluding ductless systems) must be matched with appropriate coil components to meet ENERGY STAR® criteria. Ask your contractor for details or visit www.energystar.gov.

(ENERGY STAR and the ENERGY STAR marks are registered trademarks owned by the U.S. Environmental Protection Agency.)

IMPORTANT - This product has been designed and manufactured to meet ENERGY STAR criteria for energy efficiency when matched with appropriate coil components. However, proper refrigerant charge and proper air flow are critical to achieve rated capacity and efficiency. Installation of this product should follow the manufacturer's refrigerant charging and air flow instructions. **Failure to confirm proper charge and airflow may reduce energy efficiency and shorten equipment life.**

For more technical materials such as submittals, engineering databooks, and catalogs, visit www.lghvac.com.

For continual product development, LG Electronics U.S.A., Inc., reserves the right to change specifications without notice.





©LG Electronics U.S.A., Inc.

This document, as well as all reports, illustrations, data, information, and other materials are the property of LG Electronics U.S.A., Inc.

SAFETY INSTRUCTIONS

The instructions below must be followed to prevent product malfunction, property damage, injury or death to the user or other people. Incorrect operation due to ignoring any instructions will cause harm or damage. The level of seriousness is classified by the symbols described below.

TABLE OF SYMBOLS

 DANGER	<i>This symbol indicates an imminently hazardous situation which, if not avoided, will result in death or serious injury.</i>
 WARNING	<i>This symbol indicates a potentially hazardous situation which, if not avoided, could result in death or serious injury.</i>
 CAUTION	<i>This symbol indicates a potentially hazardous situation which, if not avoided, may result in minor or moderate injury.</i>
Note:	<i>This symbol indicates situations that may result in equipment or property damage accidents only.</i>
	<i>This symbol indicates an action must not be completed.</i>

INSTALLATION

DANGER

 **Don't store or use flammable gas / combustibles near the unit.**
There is risk of fire, explosion, and physical injury or death.

WARNING

 **Do not install or remove the unit by yourself (end user).**
Ask the dealer or an LG trained service provider to install the unit.
Improper installation by the user will result in water leakage, fire, explosion, electric shock, physical injury or death.

For replacement of an installed unit, always contact an LG trained service provider.
There is risk of fire, electric shock, explosion, and physical injury or death.

The unit is shipped with refrigerant and the service valves closed.  **Do not open service valves on the unit until all non-condensibles have been removed from the piping system and authorization to do so has been obtained from the commissioning agent.**
There is a risk of physical injury or death.

 **Do not run the compressor with the service valves closed.**
There is a risk of explosion, physical injury, or death.

Periodically check that the outdoor frame is not damaged.
There is a risk of explosion, physical injury, or death.

Replace all control box and panel covers.
If cover panels are not installed securely, dust, water and animals will enter the unit, causing fire, electric shock, and physical injury or death.

Always check for system refrigerant leaks after the unit has been installed or serviced.

Exposure to high concentration levels of refrigerant gas will lead to illness or death.

Wear protective gloves when handling equipment. Sharp edges will cause personal injury.

Dispose the packing materials safely.

- *Packing materials, such as nails and other metal or wooden parts, will cause puncture wounds or other injuries.*
- *Tear apart and throw away plastic packaging bags so that children do not play with them and risk suffocation and death.*

Install the unit considering the potential for strong winds or earthquakes.

Improper installation will cause the unit to fall over, resulting in physical injury or death.

 **Do not change the settings of the protection devices.**

If the pressure switch, thermal switch, or other protection device is shorted and forced to operate improperly, or parts other than those specified by LG are used, there is risk of fire, electric shock, explosion, and physical injury or death.

 **Do not install the unit on a defective stand.**

There is a risk of physical injury.

SAFETY INSTRUCTIONS

INSTALLATION - CONTINUED

⚠ WARNING

If the air conditioner is installed in a small space, take measures to prevent the refrigerant concentration from exceeding safety limits in the event of a refrigerant leak. Consult the latest edition of ASHRAE (American Society of Heating, Refrigerating, and Air Conditioning Engineers) Standard 15. If the refrigerant leaks and safety limits are exceeded, it could result in personal injuries or death from oxygen depletion.

Install the unit in a safe location where nobody can step on or fall onto it.

There is risk of physical injury or death.

Properly insulate all cold surfaces to prevent “sweating.”
Cold surfaces such as uninsulated piping can generate condensate that could drip, causing a slippery surface that creates a risk of slipping, falling, and personal injury.

⚠ CAUTION

Be very careful when transporting the product. Failure to follow these directions will result in minor or moderate physical injury.

- **⊘ Do not attempt to carry the product without assistance.**
- **Some products use polypropylene bands for packaging. ⊘ Do not use polypropylene bands to lift the unit.**
- **Suspend the unit from the base at specified positions.**
- **Support the unit a minimum of four points to avoid slippage from rigging apparatus.**

Note:

⊘ Don't install the unit where it's directly exposed to ocean winds.

Ocean winds will cause corrosion, particularly on the condenser and evaporator fins, which, in turn could cause product malfunction or inefficient performance.

When installing the unit in a low-lying area, or a location that is not level, use a raised concrete pad or concrete blocks to provide a solid, level foundation.

This will prevent water damage and reduce abnormal vibration.

Properly insulate all cold surfaces to prevent “sweating.”
Cold surfaces such as uninsulated piping can generate condensate that will drip and cause a slippery surface condition and/or water damage to walls.

When installing the unit in a hospital, mechanical room, or similar electromagnetic field (EMF) sensitive environment, provide sufficient protection against electrical noise.
Inverter equipment, power generators, high-frequency medical equipment, or radio communication equipment will cause the air conditioner to operate improperly. The unit will also affect such equipment by creating electrical noise that disturbs medical treatment or image broadcasting.

⊘ Do not use the product for special purposes such as preserving foods, works of art, wine coolers, or other precision air conditioning applications. The equipment is designed to provide comfort cooling and heating.
There is risk of property damage.

⊘ Do not make refrigerant substitutions. Use R410A only.
If a different refrigerant is used, or air mixes with original refrigerant, the unit will malfunction and be damaged.

Keep the unit upright during installation to avoid vibration or water leakage.

⊘ Do not install the unit in a noise sensitive area.
When connecting refrigerant tubing, remember to allow for pipe expansion.
Improper piping will cause refrigerant leaks and system malfunction.

Take appropriate actions at the end of HVAC equipment life to recover, recycle, reclaim or destroy R410A refrigerant according to applicable U.S. Environmental Protection Agency (EPA) rules.

Periodically check that the outdoor frame is not damaged.
There is a risk of equipment damage.

Install the unit in a safe location where nobody can step on or fall onto it. ⊘ Do not install the unit on a defective stand.
There is risk of unit and property damage.

Install the drain hose to ensure adequate drainage.
There is a risk of water leakage and property damage.

⊘ Don't store or use flammable gas / combustibles near the unit.
There is risk of product failure.

Always check for system refrigerant leaks after the unit has been installed or serviced.
Low refrigerant levels will cause product failure

The unit is shipped with refrigerant and the service valves closed. ⊘ Do not open service valves on the unit until all non-condensibles have been removed from the piping system and authorization to do so has been obtained from the commissioning agent.
There is a risk of refrigerant contamination, refrigerant loss and equipment damage.

⊘ Do not run the compressor with the service valves closed.
There is a risk of equipment damage.

SAFETY INSTRUCTIONS

WIRING

⚠ DANGER

High voltage electricity is required to operate this system. Adhere to the National Electrical Codes and these instructions when wiring.

Improper connections and inadequate grounding can cause accidental injury or death.

Always ground the unit following local, state, and National Electrical Codes.

Turn the power off at the nearest disconnect before servicing the equipment.

Electrical shock can cause physical injury or death.

Properly size all circuit breakers or fuses.

There is risk of fire, electric shock, explosion, physical injury or death.

⚠ WARNING

The information contained in this manual is intended for use by an industry-qualified, experienced, certified electrician familiar with the U.S. National Electric Code (NEC) who is equipped with the proper tools and test instruments.

Failure to carefully read and follow all instructions in this manual can result in personal injury or death.

All electric work must be performed by a licensed electrician and conform to local building codes or, in the absence of local codes, with the National Electrical Code, and the instructions given in this manual.

If the power source capacity is inadequate or the electric work is not performed properly, it will result in fire, electric shock, physical injury or death.

Refer to local, state, and federal codes, and use power wires of sufficient current capacity and rating.

Wires that are too small will generate heat and cause a fire.

Secure all field wiring connections with appropriate wire strain relief.

Improperly securing wires will create undue stress on equipment power lugs. Inadequate connections will generate heat, cause a fire and physical injury or death.

Note:

The information contained in this manual is intended for use by an industry-qualified, experienced, certified electrician familiar with the U.S. National Electric Code (NEC) who is equipped with the proper tools and test instruments.

Failure to carefully read and follow all instructions in this manual can result in equipment malfunction and property damage.

SAFETY INSTRUCTIONS

OPERATION

DANGER

 Do not provide power to or operate the unit if it is flooded or submerged.

There is risk of fire, electric shock, physical injury or death.

Use a dedicated power source for this product.

There is risk of fire, electric shock, physical injury or death.

 Do not operate the disconnect switch with wet hands.

There is risk of fire, electric shock, physical injury or death.

WARNING

 Do not allow water, dirt, or animals to enter the unit.

There is risk of fire, electric shock, physical injury or death.

 Avoid excessive cooling, and periodically perform ventilation to the unit.

Inadequate ventilation is a health hazard.

 Do not touch the refrigerant piping during or after operation.

It can cause burns or frostbite.

 Do not operate the unit with the panel(s) or protective cover(s) removed; keep fingers and clothing away from moving parts.

The rotating, hot, cold, and high-voltage parts of the unit can cause physical injury or death.

Periodically verify the equipment mounts have not deteriorated.

If the base collapses, the unit could fall and cause physical injury or death.

CAUTION

 To avoid physical injury, use caution when cleaning or servicing the air conditioner.

Note:

Clean up the site after installation is finished, and check that no metal scraps, screws, or bits of wiring have been left inside or surrounding the unit.

 Do not use this equipment in mission critical or special-purpose applications such as preserving foods, works of art, wine coolers or refrigeration. The equipment is designed to provide comfort cooling and heating.

Provide power to the compressor crankcase heaters at least six (6) hours before operation begins.

Starting operation with a cold compressor sump(s) will result in severe bearing damage to the compressor(s). Keep the power switch on during the operational season.

Periodically verify that the hardware securing the unit has not deteriorated.





If the unit falls from its installed location, it can cause property damage, product failure, physical injury or death.

If gas leaks out, ventilate the area before operating the unit.

If the unit is mounted in an enclosed, low-lying, or poorly ventilated area, and the system develops a refrigerant leak, it will cause fire, electric shock, explosion, physical injury or death.

Periodically check power cord and plug for damage.

Cord must be replaced by the manufacturer, its service agent, or similar qualified persons in order to avoid physical injury and/or electric shock.

 Do not open the inlet grille of the unit during operation.
 Do not operate the unit with the panels or guards removed.  Do not insert hands or other objects through the inlet or outlet when the unit is plugged in.  Do not touch the electrostatic filter, if the unit includes one.

The unit contains sharp, rotating, hot, and high voltage parts that can cause personal injury and/or electric shock.

Securely attach the electrical part cover to the indoor unit and the service panel to the outdoor unit.

Non-secured covers can result in burns or electric shock due to dust or water in the service panel.

 Do not block the inlet or outlet.

Unit will malfunction.

Securely attach the electrical part cover to the indoor unit and the service panel to the outdoor unit.

Non-secured covers can result in malfunction due to dust or water in the service panel.

Periodically verify the equipment mounts have not deteriorated.

If the base collapses, the unit could fall and cause property damage or product failure.

 Do not allow water, dirt, or animals to enter the unit.

There is risk of unit failure.

TABLE OF CONTENTS

Safety Instructions	3-6	Electrical System Installation	44-52
General Data	8-11	<i>Safety Guidelines</i>	44
<i>Unit Nomenclature</i>	8	<i>Connections and Specifications</i>	44-47
<i>Parts</i>	9	<i>Controller Options</i>	48
<i>Specifications</i>	10	<i>Indoor Unit Electrical Connections</i>	49-50
<i>Electrical</i>	11	<i>Outdoor Unit Electrical Connections</i>	51-52
General Installation Guidelines	12-22	Final Installation Procedures	53-62
<i>Outdoor Unit Location Selection</i>	12-14	<i>Triple Leak / Pressure Test</i>	53-54
<i>Required Outdoor Unit Clearances</i>	15	<i>Deep Evacuation Test</i>	54-55
<i>Rigging and Lifting</i>	16	<i>Triple Evacuation Test</i>	55-56
<i>Outdoor Unit Mounting</i>	16-17	<i>Refrigerant Trim Charge</i>	57
<i>Required Indoor Unit Clearances</i>	18	<i>Finishing the Job</i>	57
<i>Indoor Unit Mounting</i>	19-22	<i>Reattaching the Indoor Unit Bottom Cover</i>	58
General Refrigerant Piping System Information	23-32	<i>Air Filter Disassembly and Assembly</i>	59
<i>Refrigerant Safety Standards</i>	23	<i>Installing Batteries, Test Run, Performance Evaluation</i>	60
<i>Device Connection Limitations</i>	23	<i>Installer Mode, Heating Only Mode</i>	61
<i>Selecting Copper Piping</i>	24	<i>Cooling Only Mode, Pump Down Procedure</i>	62
<i>Copper Expansion and Contraction</i>	25-26	Troubleshooting	63-67
<i>Piping Materials and Handling</i>	27	<i>LG SIMS - Self Diagnosis Functions</i>	63-64
<i>Refrigerant System Engineering</i>	28-30	<i>Error Codes</i>	65-66
<i>Flaring and Brazing Procedures</i>	31-32	<i>Refrigerant Leaks</i>	67
Refrigerant Piping Connections	33-43	Installation Checklist	68
<i>Installation Overview</i>	33		
<i>Special Applications</i>	34		
<i>Outdoor Unit Connections</i>	35		
<i>Indoor Unit Connections</i>	36-38		
<i>Outdoor Unit Drain Piping</i>	39		
<i>Indoor Unit Drain Hose</i>	39-41		
<i>Bundling</i>	41		
<i>Insulation</i>	42-43		

GENERAL DATA

Unit Nomenclature

Indoor Units and Outdoor Units

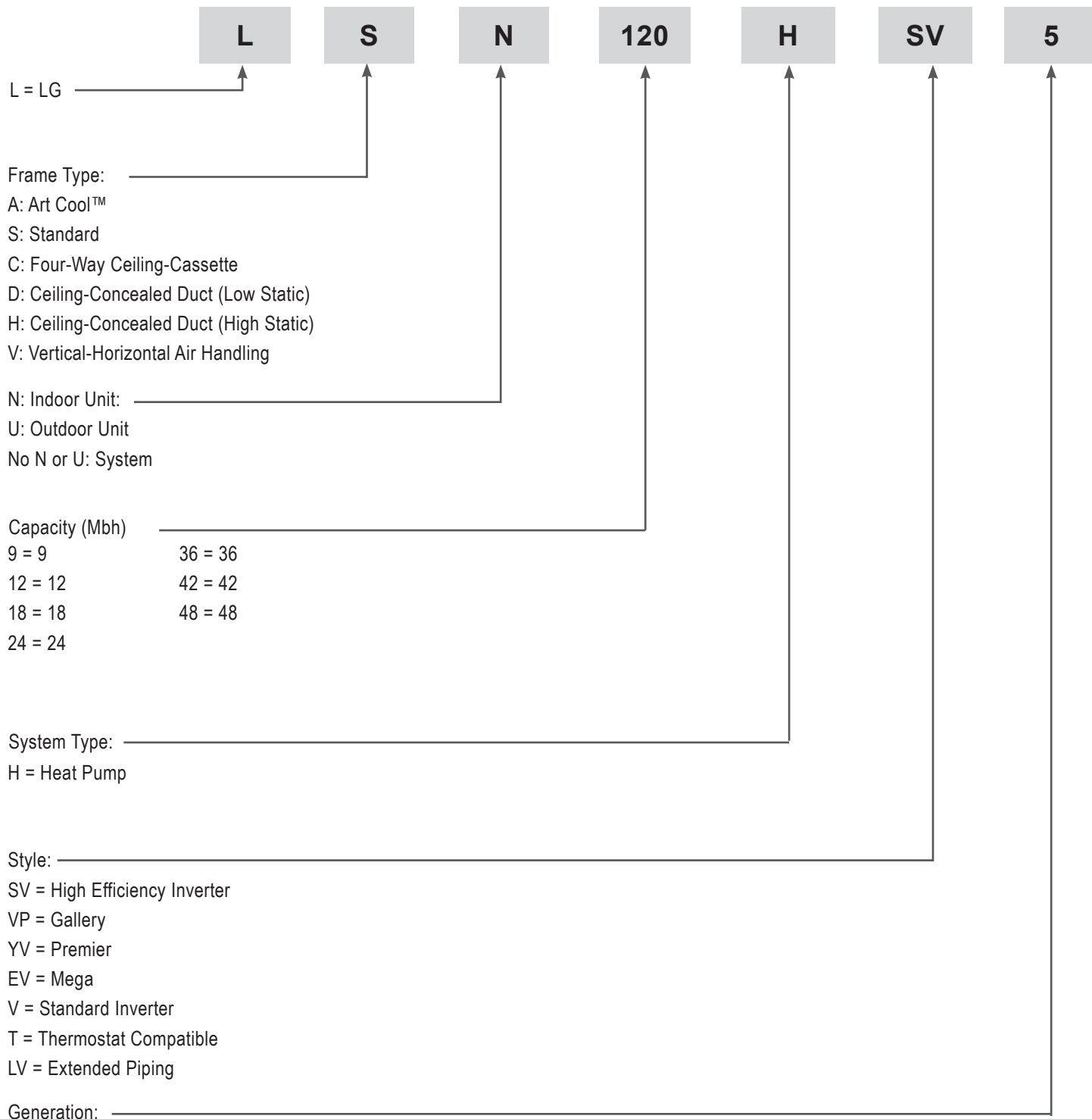



Required Tools (field provided)

- Level
- Screwdriver
- Electrical lineman pliers
- Electric drill
- Hole saw
- Drill
- Flaring tool set
- Tubing cutter
- Tube/pipe reamer
- Torque wrenches
- Allen wrench
- Gas-leak detector
- Thermometer
- Measuring tape
- Multimeter
- Ammeter

Required Parts (field provided)

- Connecting cable (power and control)
- Pipes - vapor line and liquid line, with insulation
- Insulated drain hose
- Additional drain hose

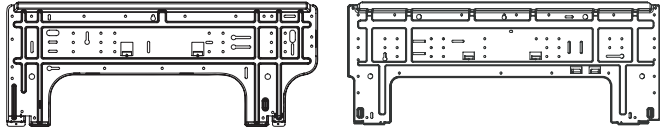
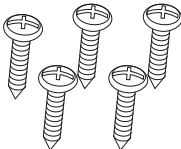
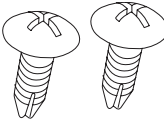
Included Parts

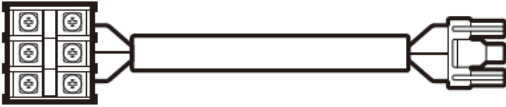
Part	Quantity	Image
Installation Plate	One (1)	 <p>9,000 ~ 12,000 Btu/h Indoor Units 18,000 Btu/h Indoor Units</p>
Type "A" Screws	Five (5)	
Type "B" Screws (M4 x 12L)	Two (2)	
Wireless Controller with Holder AKB74955602	One (1)	
Terminal Connector	One (1)	

GENERAL DATA

Specifications

Table 1: Single Zone High Efficiency System Specifications.

System Model Number (IDU/ODU)	LS090HSV5 (LSN090HSV5/LSU090HSV5)	LS120HSV5 (LSN120HSV5/LSU120HSV5)	LS181HSV5 (LSN181HSV5/LSU181HSV5)
Cooling Capacity (Min/Rated/Max) (Btu/h)	1,023 ~ 9,000 ~ 12,625	1,023 ~ 12,000 ~ 13,785	3,070 ~ 18,000 ~ 29,515
Cooling Power Input ¹ (kW)	0.20 ~ 0.62 ~ 0.87	0.20 ~ 0.96 ~ 1.35	0.30 ~ 1.43 ~ 2.00
Heating Capacity (Min/Rated/Max) (Btu/h)	1,023 ~ 10,900 ~ 17,061	1,023 ~ 13,600 ~ 22,178	3,070 ~ 21,600 ~ 38,898
Heating Power Input ¹ (kW)	0.20 ~ 0.71 ~ 1.89	0.20 ~ 1.04 ~ 1.97	0.66 ~ 1.73 ~ 3.98
COP	4.50	3.83	3.66
Maximum Heating Capacity (Btu/h)			
Outdoor 17 °F (WB)/Indoor 70 °F (DB)	11,080 (102%)	13,810 (102%)	22,340 (103%)
Outdoor 5°F (WB)/Indoor 70 °F (DB)	9,570 (88%)	11,930 (88%)	19,300 (89%)
Outdoor -4 °F (WB)/Indoor 70 °F (DB)	8,310 (76%)	10,360 (76%)	16,760 (77%)
EER2	14.5	12.5	12.55
SEER2	23.2	22.0	22.0
HSPF2	10.2	10.0	9.5
Power Supply (V/Hz/Ø)	208-230 / 60 / 1		
Outdoor Unit Operating Range²			
Cooling (°F DB)	14 to 118		
Heating (°F WB)	-4 to 65		
Indoor Unit Operating Range			
Cooling (°F WB)	53 to 75		
Heating (°F DB)	60 to 86		
Indoor Temperature Setting Range			
Cooling (°F)	64 to 86		
Heating (°F)	60 to 86		
Unit Data			
Refrigerant Type ³	R410A		
Refrigerant Control	EEV		
IDU Sound Pressure Level dB(A) (H/M/L/Sleep) ⁴	41 / 35 / 25 / 21	41 / 35 / 25 / 21	47 / 42 / 37 / 31
ODU Sound Pressure Level dB(A) ⁴ (Cool/Heat)	47 / 51	47 / 51	55 / 55
Unit Weight (lbs)			
IDU (Net/Shipping)	18.3 / 23.4	18.3 / 23.4	25.6 / 32.2
ODU (Net/Shipping)	74.1 / 78.9	74.1 / 78.9	127.9 / 145.5
Power Wiring/Communication Cable ⁵ (No.x AWG)	4 x 14		
Compressor			
Compressor Type (Qty)	Twin Rotary (1)	Twin Rotary (1)	Twin Rotary (1)
Fan			
Indoor Unit Type (Qty)	Cross Flow (1)		
Outdoor Unit Type (Qty)	Propeller (1)		
Motor/Drive	Brushless Digitally Controlled / Direct		
Airflow Rate			
Indoor Unit (Max. / H / M / L [CFM])	Cooling	459 / 338 / 317 / 194	459 / 338 / 317 / 194
	Heating	459 / 338 / 317 / 229	459 / 338 / 317 / 229
Outdoor Unit (Max. [CFM])	1,165	1,165	2,119
Piping			
Liquid Line (in.)	ø1/4	ø1/4	ø3/8
Vapor Line (in.)	ø3/8	ø3/8	ø5/8
Condensate Drain O.D. / I.D. (in.)	27/32, 5/8	27/32, 5/8	27/32, 5/8
Additional Refrigerant Charge (oz./ft.)	0.22	0.22	0.38
Pipe Length ⁶ (Minimum/Standard/Maximum) (ft.)	9.8 / 24.6 / 82	9.8 / 24.6 / 82	9.8 / 24.6 / 114.8
Piping Length ⁶ (no add'l refrigerant, ft.)	41	41	24.6
Max Elevation Difference (ft.)	49.2	49.2	49.2

EEV: Electronic Expansion Valve IDU: Indoor Unit ODU: Outdoor Unit

This unit comes with a dry helium charge.

This data is rated 0 ft above sea level with 24.6 of refrigerant line per indoor unit and a 0 ft level difference outdoor and indoor units.

Cooling capacity rating obtained with air entering the indoor unit at 80°F dry bulb (DB) and 67°F wet bulb (WB) and outdoor ambient conditions of 95°F dry bulb (DB) and 75°F wet bulb (WB).

Heating capacity rating obtained with air entering the indoor unit at 70°F dry bulb (DB) and 59°F wet bulb (WB) and outdoor ambient conditions of 47°F dry bulb (DB) and 43°F wet bulb (WB).

¹Power Input is rated at high speed.

²Optional low Ambient Wind Baffle Kit allows operation down to 0°F in cooling mode.

³Take appropriate actions at the end of HVAC equipment life to recover, recycle, reclaim or destroy R410A refrigerant according to applicable regulations (40 CFR Part 82, Subpart F) under section 608 of CAA.

⁴Sound Pressure levels are tested in an anechoic chamber under ISO Standard 1996.

⁵All communication / connection (power) cable from the outdoor unit to the indoor unit is field supplied and must be a minimum of four-conductor, 14 AWG, stranded, shielded or unshielded (if shielded, it must be grounded to the chassis of the outdoor unit only), and must comply with applicable local and national codes.

⁶Piping lengths are equivalent.

GENERAL DATA

Electrical

Electrical Data

Table 2: Single Zone High Efficiency Standard Wall Mount System Electrical Data.

Nominal Tons	Unit Model No.	Hertz	Voltage	Voltage Range (Min. to Max.)	MCA	MOP	Compressor Quantity	LRA	Compressor Motor RLA		Outdoor Fan Motor		Indoor Fan Motor
									Cooling	Heating	W	FLA	FLA
3/4	LS090HSV5	60	208 - 230	187 - 253	10.0	15.0	1	7.5	7.0	7.0	43	0.4	0.4
1	LS120HSV5				10.0	15.0	1	7.5	7.0	7.0	43	0.4	0.4
1-1/2	LS181HSV5				19.0	30.0	1	17.0	12.6	14.3	124	0.78	0.4

Voltage tolerance is $\pm 10\%$.
 Maximum allowable voltage unbalance is 2%.
 MCA = Minimum Circuit Ampacity.
 Maximum Overcurrent Protection (MOP) is calculated as follows: (Largest motor FLA x 2.25) + (Sum of other motor

FLA) rounded down to the nearest standard fuse size.
 RLA = Rated Load Amps.
 FLA = Full Load Amps.
 W: Fan Motor Rated Output (W)
 LRA = Locked Rotor Amps

GENERAL INSTALLATION GUIDELINES

Outdoor Unit Location Selection

Selecting the Best Location for the Outdoor Unit

⚠ DANGER

- ⚠ Do not install the unit in an area where combustible gas will generate, flow, stagnate, or leak. These conditions can cause a fire, resulting in bodily injury or death.
- ⚠ Do not install the unit in a location where acidic solution and spray (sulfur) are often used as it can cause bodily injury or death.
- ⚠ Do not use the unit in environments where oil, steam, or sulfuric gas are present as it can cause bodily injury or death.

⚠ CAUTION

When deciding on a location to place the outdoor unit, be sure to choose an area where run-off water from defrost cycle will not accumulate and freeze on sidewalks or driveways, which will create unsafe conditions. Properly install and insulate any drain hoses to prevent the hose from freezing, cracking, leaking, and causing unsafe conditions from frozen condensate.

⚠ WARNING

Install a fence to prevent vermin from crawling into the unit or unauthorized individuals from accessing it. Vermin and unauthorized individuals will cause a fire, electric shock, physical injury or death. Follow the placement guidelines set forth in "Clearance Requirements".

Note:

Install a fence to prevent vermin from crawling into the unit or unauthorized individuals from accessing it. Vermin and unauthorized individuals will damage the unit. Follow the placement guidelines set forth in "Clearance Requirements".

Select a location for installing the outdoor unit that will meet the following conditions:

- Where there is enough structural strength to bear the weight of the unit.
- A location that allows for optimum air flow and is easily accessible for inspection, maintenance, and service.
- Where piping between the outdoor unit and indoor unit is within allowable limits.
- Include space for drainage to ensure condensate flows properly out of the unit when it is in heating mode. ⚠ Avoid placing the outdoor unit in a low-lying area where water could accumulate.
- If the outdoor unit is installed in a highly humid environment (near an ocean, lake, etc.), ensure that the site is well-ventilated and has a lot of natural light (Example: Install on a rooftop).

⚠ Dont's

- Where it will be subjected to direct thermal radiation from other heat sources, or an area that would expose the outdoor unit to heat or steam like discharge from boiler stacks, chimneys, steam relief ports, other air conditioning units, kitchen vents, plumbing vents, and other sources of extreme temperatures.
- Where high-frequency electrical noise / electromagnetic waves will affect operation.
- Where operating sound from the unit will disturb inhabitants of surrounding buildings.
- Where the unit will be exposed to direct, strong winds.
- Where the discharge of one outdoor unit will blow into the inlet side of an adjacent unit (when installing multiple outdoor units).

Planning for Snow and Ice

To ensure the outdoor unit operates properly, certain measures are required in locations where there is a possibility of heavy snowfall or severe windchill or cold:

1. Prepare for severe winter wind chills and heavy snowfall, even in areas of the country where these are unusual phenomena.
2. Position the outdoor unit so that its airflow fans are not buried by direct, heavy snowfall. If snow piles up and blocks the airflow, the system will malfunction.
3. Remove any snow that has accumulated four (4) inches or more on the top of the outdoor unit.
4. In climates that can experience significant snow buildup, mount the outdoor unit on a raised, field-provided platform or stand. The raised support platform must be high enough to allow the unit to remain above possible snow drifts, and must be higher than the maximum anticipated snowfall for the location.
5. Design the mounting base to prevent snow accumulation on the platform in front or back of the unit frame.
6. Provide a field fabricated snow protection hood to keep snow and ice and/or drifting snow from accumulating on the coil surfaces.
7. To prevent snow and heavy rain from entering the outdoor unit, install the condenser air inlets and outlets facing away from direct winds.
8. Consider tie-down requirements in case of high winds or where required by local codes.

GENERAL INSTALLATION GUIDELINES

Outdoor Unit Location Selection

Planning for Snow and Ice, continued.

⚠ CAUTION

When deciding on a location to place the outdoor unit, be sure to choose an area where run-off water from defrost cycle will not accumulate and freeze on sidewalks or driveways, which will create unsafe conditions. Properly install and insulate any drain hoses to prevent the hose from freezing, cracking, leaking, and causing unsafe conditions from frozen condensate.

Note:

Choose an area where run-off water from defrost cycle will not accumulate and freeze on sidewalks or driveways. Properly install and insulate any drain hoses to prevent the hose from freezing, cracking, leaking, and damaging the outdoor unit.

Note:

The indoor unit will take longer to provide heat, or heating performance will be reduced in winter if the unit is installed:

1. In a narrow, shady location.
2. Near a location that has a lot of ground moisture.
3. In a highly humid environment.
4. In an area in which condensate does not drain properly.

Tie-Downs and Lightning Protection

Tie-Downs

- The strength of the roof must be checked before installing the outdoor units.
- If the installation site is prone to high winds or earthquakes, when installing on the wall or roof, securely anchor the mounting base using a field-provided tie-down configuration approved by a local professional engineer.
- The overall tie-down configuration must be approved by a local professional engineer.

Note:

Always refer to local code when using a wind restraint system.

Lightning Protection

- To protect the outdoor unit from lightning, it must be placed within the specified lightning safety zone.

Table 3: Safety Zone Specifications.

Building Height (feet)	66	98	148	197
Protection Angle (°)	55	45	35	25

- Power cable and communication cable must be installed five (5) feet away from lightning rod.
- A high-resistance ground system must be included to protect against induced lightning or indirect strike.

Note:

If the building does not include lightning protection, the outdoor unit will be damaged from a lightning strike. Inform the customer of this possibility in advance.

Figure 1: Lightning Protection Diagram.

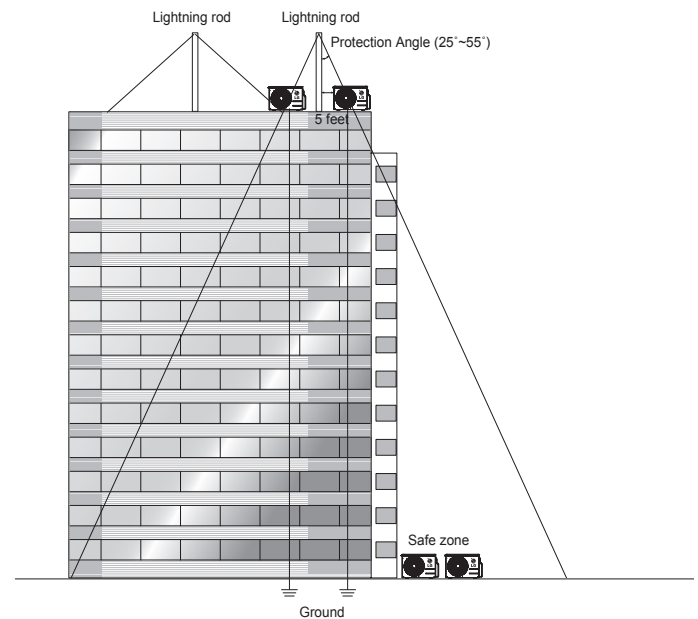

GENERAL INSTALLATION GUIDELINES

Outdoor Unit Location Selection

Oceanside Applications

Use of a Windbreak to Shield from Sea Wind

Note:

Ocean winds will cause corrosion, particularly on the condenser and evaporator fins, which, in turn could cause product malfunction or inefficient performance.

- ⚠️ Avoid installing the outdoor unit where it would be directly exposed to ocean winds.
- Install the outdoor unit on the side of the building opposite from direct ocean winds.
- Select a location with good drainage.
- Periodically clean dust or salt particles off of the heat exchanger with water.
- If the outdoor unit must be placed in a location where it would be subjected to direct ocean winds, install a concrete windbreak strong enough to block any winds.
- Windbreak must be more than 150% of the outdoor unit's height. There must be 2 to 3-1/2 inches of clearance between the outdoor unit and the windbreaker for purposes of air flow.

Note:

Additional anti-corrosion treatment will need to be applied to the outdoor unit at oceanside locations.

Use of a Building to Shield from Sea Wind

If a windbreak is not possible, a building or larger structure must be used to shield the outdoor unit from direct exposure to the sea wind. The unit must be placed on the side of the building directly opposite to the direction of the wind as shown at right.

Figure 2: Oceanside Placement Using Windbreak.

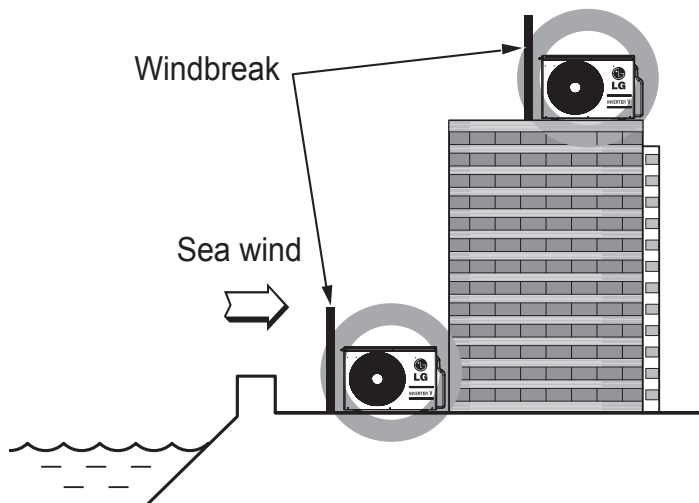
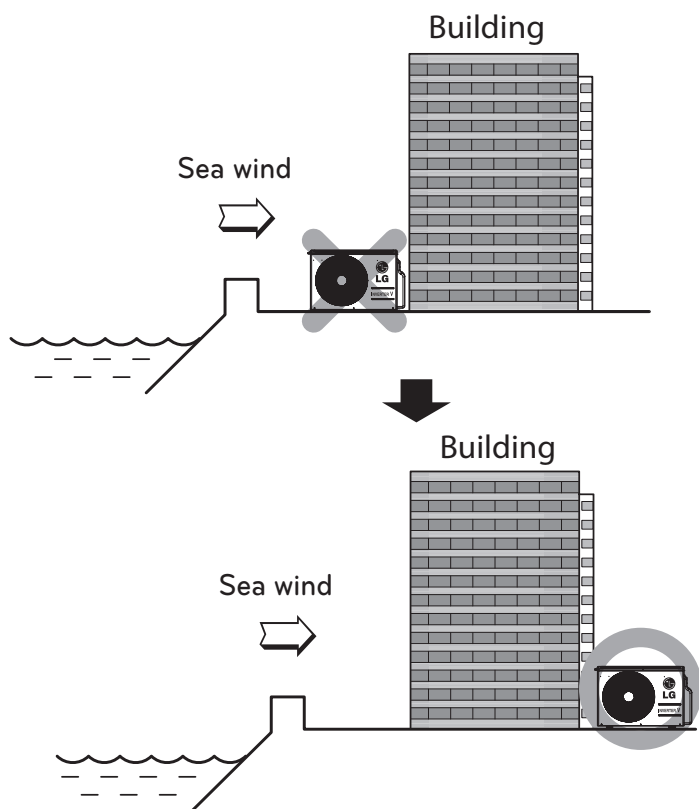

Figure 3: Placement Using Building as Shield.



GENERAL INSTALLATION GUIDELINES

Required Outdoor Unit Clearances

Minimum Clearance Requirements for Single Fan Outdoor Units

Proper clearance for the outdoor unit coil is critical for proper operation. When installing the outdoor unit, consider service, inlet and outlet, and minimum allowable space requirements as illustrated in the diagrams below.

Specific clearance requirements in the diagram below are for single fan outdoor units. Figure below shows the overall minimum clearances that must be observed for safe operation and adequate airflow around the outdoor unit.

When placing the outdoor unit under an overhang, awning, sunroof or other “roof-like structure”, observe the clearance requirements (as shown in Cases 1 and 2) for height in relation to the unit. This clearance ensures that heat radiation from the condenser is not restricted around the unit.

Adhere to all clearance requirements if installing the unit on a roof. Be sure to level the unit and ensure that the unit is adequately anchored. Consult local codes for rooftop mounting requirements. To have successful service access to the outdoor unit, see Figure below for minimum spacing. When installing multiple outdoor units, see Cases 4 and 5 in Figure 4 for correct spacing requirements. Outdoor unit fans draw air from the back of the unit and discharge out the front. Place units back to back and front to front.

Note:

If the outdoor unit is installed between standard and minimum clearances, capacity decreases approximately 10%.

Figure 4: Single Fan Outdoor Unit Service Access and Allowable Clearances Diagram.

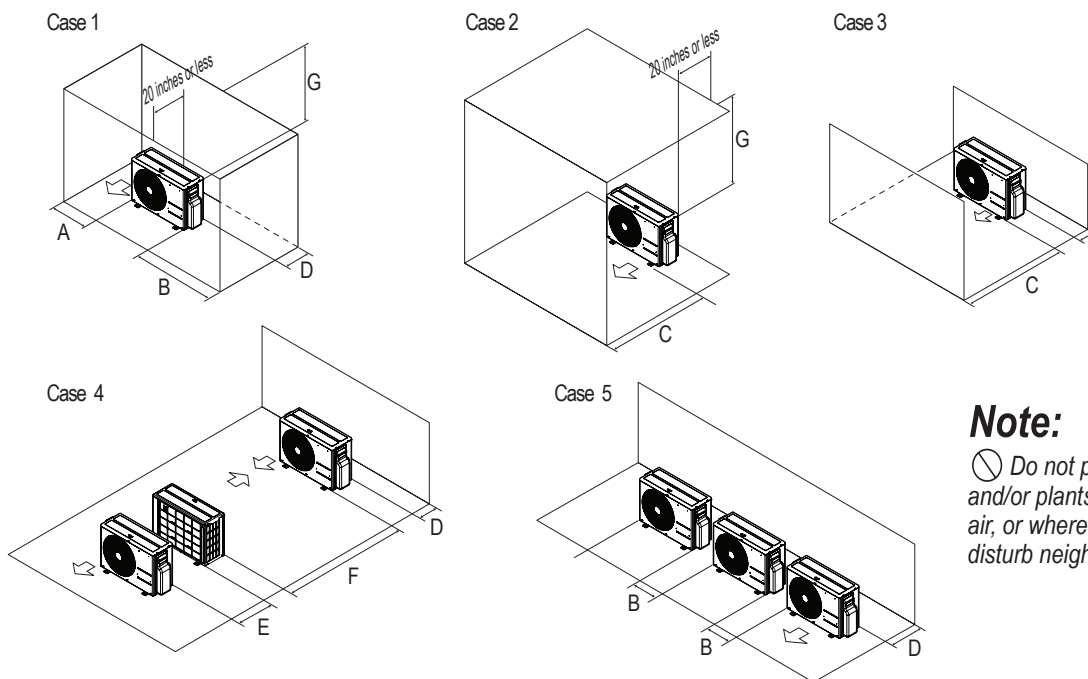

Note:

⊘ Do not place the unit where animals and/or plants will be in the path of the warm air, or where the warm air and/or noise will disturb neighbors.

Table 4: Single Fan Outdoor Unit Service Access and Allowable Clearances Diagram Legend.

Unit: Inch		A	B	C	D	E	F	G
Case 1	Standard	12	24	-	12	-	-	-
	Minimum	4	10	-	4	-	-	40
Case 2	Standard	-	-	20	-	-	-	-
	Minimum	-	-	14	-	-	-	40
Case 3	Standard	-	-	20	12	-	-	-
	Minimum	-	-	14	4	-	-	-
Case 4	Standard	-	-	-	12	24	-	-
	Minimum	-	-	-	4	8	79	-
Case 5	Standard	-	24	-	12	-	-	-
	Minimum	-	10	-	4	-	-	-

GENERAL INSTALLATION GUIDELINES

Rigging and Lifting / Outdoor Unit Mounting

Rigging and Lifting Instructions

⚠ WARNING

Wear protective gloves and safety goggles when handling equipment. Sharp edges will cause personal injury.

Dispose of the packing materials safely.

- Packing materials, such as nails and other metal or wooden parts, will cause puncture wounds or other injuries.
- Tear apart and throw away plastic packaging bags so that children do not play with them and risk suffocation and death.

⚠ CAUTION

- Be very careful when transporting the product. There is a risk of the product falling and causing physical injury.
- Use appropriate moving equipment to transport each frame; ensure the equipment is capable of supporting the weights listed.
- Some products use polypropylene bands for packaging. Ⓞ Do not use polypropylene bands to lift the unit.
- Support the outdoor unit at a minimum of four points to avoid slippage from rigging apparatus.

Note:

- Make sure the outdoor unit is in its original packaging to avoid damage during local transport.
- At the time of delivery, the package must be checked for any damage (exterior and interior). Report any damage to the carrier claims agent immediately.
- Handle the outdoor unit with care. Keep the outdoor unit upright to avoid damaging inside components.
- If a forklift is to transport the outdoor unit, the forklift arms must pass through the openings at the bottom.
- If a crane is to suspend the outdoor unit, it is required that two (2) ropes at least twenty-three (23) feet in length be used. Pass the ropes under the unit. Pass the rope through the two (2) forklift slots each at the front and rear of the outdoor unit.
- To prevent damage to the outdoor unit, always lift the unit with the ropes attached at four (4) points at an angle of $\leq 40^\circ$.
- Always include padding to protect the outdoor unit from rope damage, and take into consideration the outdoor unit's center of gravity.

General Outdoor Unit Mounting

Any underlying structure or foundation must be designed to support the weight of the outdoor unit. Ⓞ Avoid placing the unit in a low lying area where water and ice will accumulate. Securely attach the outdoor unit to a condenser pad, base rails, or a mounting platform that is solidly anchored to the ground or building structure. When installing the outdoor unit on the wall or roof top, securely anchor the mounting base to account for wind, earthquakes, or vibration.

Anchoring the Outdoor Unit

- Tightly anchor the outdoor unit with a bolt and nut to a concrete or rigid platform (see next page for more details).
- When installing on a wall (with field-supplied brackets), roof, or rooftop, securely anchor the mounting platform with nails, taking into consideration the possibility of strong winds or earthquakes.
- If there is a possibility of vibration from the outdoor unit transmitting to the building, add an anti-vibration material.

Note:

Follow applicable local codes for clearance, mounting, anchor and vibration attenuation requirements.

Figure 5: Examples of Outdoor Unit Mounting Methods.

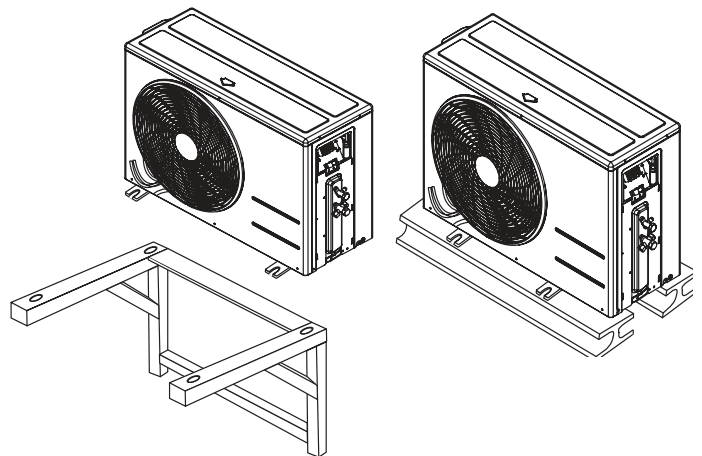

GENERAL INSTALLATION GUIDELINES

Outdoor Unit Mounting

Concrete Platform Specifications

- Concrete foundations must be made of one part cement, two parts sand, and four parts gravel.
- The surface of the foundation must be finished with mortar with rounded edges, and weatherproofed.

Figure 6: Example of Using an Insert for a Hole in a Reinforced Concrete Beam.

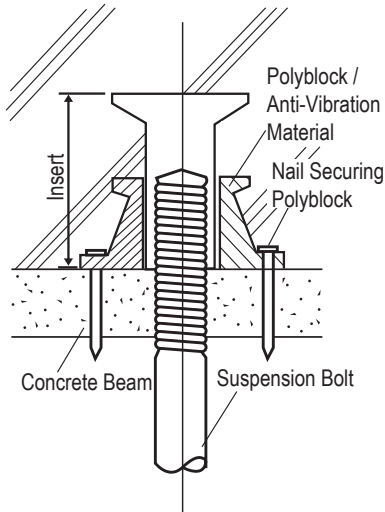
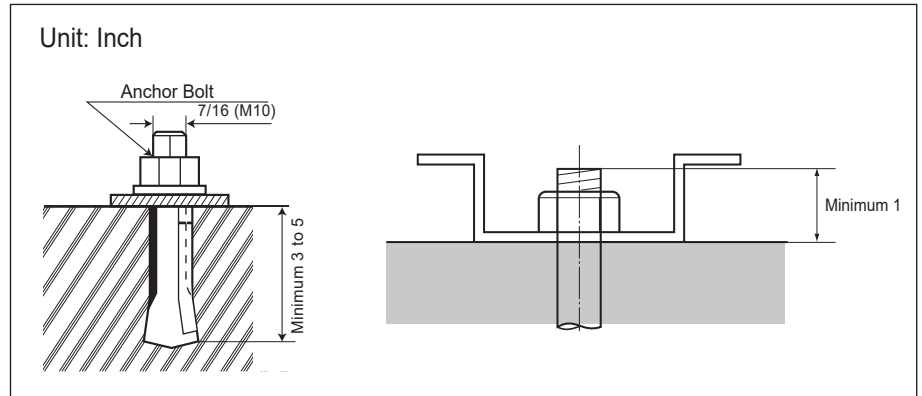
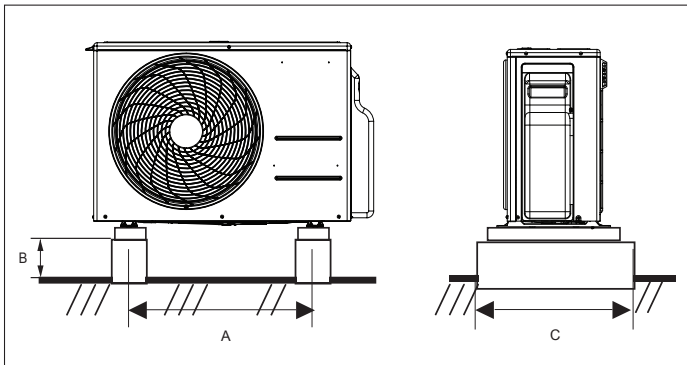

Figure 7: Close up of Bolt Attachment.



Outdoor Unit Platform Dimensional Requirements

Figure 8: Single Zone High Efficiency Standard Wall Mount Outdoor Units.



Bolting the Outdoor Unit to the Platform

1. Ensure that the concrete platform will not degrade easily, and has enough structural strength to bear the weight of the unit.
2. Include an H-beam support. Firmly attach the corners, otherwise the support will bend.
3. Use a hexagon nut.
4. Use anti-vibration material.
5. Include enough space around the concrete foundation for condensate drainage.
6. Seal all wiring and piping access holes to prevent insects from entering the unit.

Table 5: Outdoor Unit Foundation Specifications.

Model	Foundation (Inches)			Leg Thickness (Inches)
	A	B	C	
LSU090HSV5, LSU120HSV5	22	Minimum 4	14-19/32	1/16
LSU181HSV5	21-1/2	Minimum 4	14-19/32	3/32

Note:

Review the specifications for field-supplied pad mounts or brackets to verify that outdoor dimension requirements are met.

Figure 9: Bolting the Outdoor Unit to the Platform (Piping Location Will Differ Depending on Outdoor Unit Model).

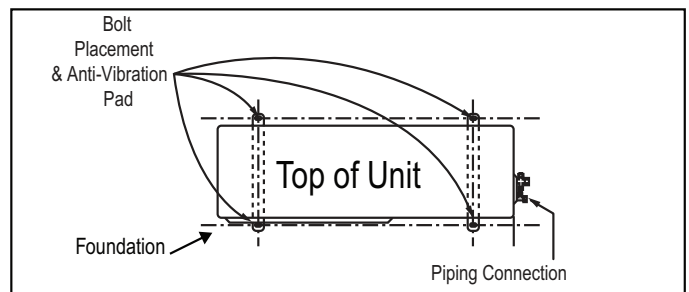

Note:

All referenced materials are to be field-supplied. Images are not to scale.

GENERAL INSTALLATION GUIDELINES

Required Indoor Unit Clearances

Note:

Follow required best practices when choosing an indoor location for the single zone indoor unit.

Dos

- Follow the table at right for minimum clearance of indoor unit from the top of the unit to the ceiling.
- Clearance gap between any wall or enclosure and the left or right side of the unit must be greater than 4 inches. Ensure there is sufficient maintenance space.
- Unit must be at least 6.5 feet from the floor for adequate clearance.
- Place the unit where drainage can be obtained easily. Condensation drain must be conveniently routed away from the unit.
- Locate the indoor unit in a location where it can be easily connected to the outdoor unit within allowable limits.
- Use a metal detector to locate studs in the walls. Anchor unit following stud location to prevent damage to the wall.

⊘ Dont's

- Do not install the unit near a heat or steam source, or where considerable amounts of oil, iron powder, or flour are used. (These materials will generate condensate, cause a reduction in heat exchanger efficiency, or the drain to malfunction. If this is a potential problem, install a ventilation fan large enough to vent out these materials.)
- Ensure there are no obstacles to air circulation around the unit; keep proper distances from ceilings, doorways, floor, walls, etc.
- Do not install in an area where operation sound will disturb occupants--place the unit where noise prevention is taken into consideration
- Do not install near doorway.
- Avoid installing the unit near high-frequency generators.

⚠ WARNING

The unit must not be installed where sulfuric acid and flammable or corrosive gases are generated, vented into, or stored. There is risk of fire, explosion, and physical injury or death.

The unit will be damaged, will malfunction, and / or will not operate as designed if installed in any of the conditions listed.

Note:

- ⊘ Indoor units (IDUs) must not be placed in an environment where the IDUs will be exposed to harmful volatile organic compounds (VOCs) or in environments where there is improper air make up or supply or inadequate ventilation. If there are concerns about VOCs in the environment where the IDUs are installed, proper air make up or supply and/or adequate ventilation must be provided. Additionally, in buildings where IDUs will be exposed to VOCs, consider a third party factory-applied epoxy coating to the fan coils for each IDU where the entire coil is dipped, not sprayed.
- If the unit is installed near a body of water, the installation parts are at risk of corroding. Appropriate anti-corrosion methods must be taken for the unit and all installation parts.

Installing in an Area Exposed to Unconditioned Air

In some installation applications, areas (floors, walls) in some rooms will be exposed to unconditioned air (room can be above or next to an unheated garage or storeroom). To countermeasure:

- Verify that carpet is or will be installed (carpet could increase the temperature by three [3] degrees).
- Add insulation between the floor joists.
- Install radiant heat or another type of heating system to the floor.

Figure 10: Single Zone High Efficiency Standard Wall Mount Indoor Unit Clearance Requirements.

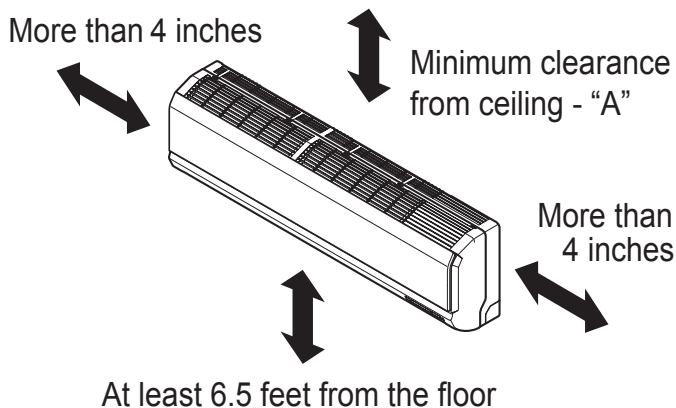
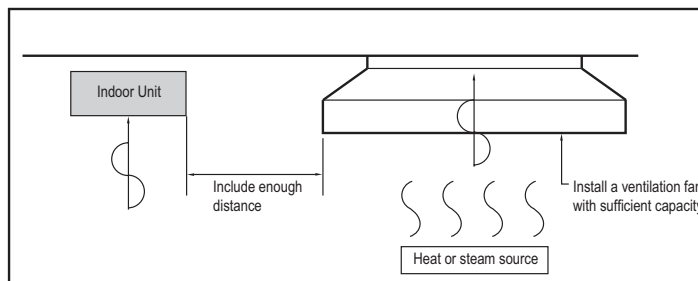

Table 6: Single Zone High Efficiency Standard Wall Mount Indoor Unit Ceiling Clearances.

"A" Ceiling Clearance (inches)	Indoor Unit Model(s)
5	LSN090HSV5, LSN120HSV5
8	LSN181HSV5

Figure 11: Installing Near a Heat or Steam Source.



GENERAL INSTALLATION GUIDELINES

Indoor Unit Mounting

Drilling the Piping Hole in the Wall

Follow all piping clearance recommendations.

- Using a 2-9/16 inch hole core drill bit, drill a hole at either the right or left side of the wall mounting, pre-chosen following installation guidelines and application needs.
 - The slant of the hole must be 3/16" to 5/16" from level with the slant being upward on the indoor unit side and downward on the outdoor unit side.
- Finish off the newly drilled hole as shown with bushing and sleeve covering to prevent damage to the insulation and piping.

Figure 12: Drilling Piping Hole.

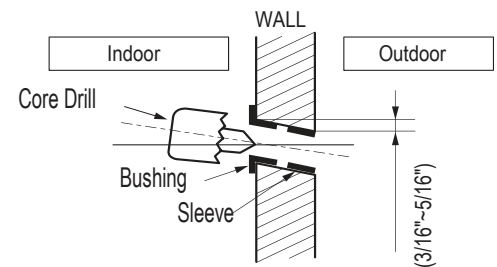

Mounting the Installation Plate to the Wall

Follow the procedure below and general best practices when mounting the indoor unit's installation plate to a wall.

- The wall mounted indoor unit is shipped with the installation plate attached to its back. To remove, unscrew the one (1) screw that holds the installation plate to the back of the indoor unit.
- Align the centerline using a leveling tool. Measure the wall and mark the centerline.
- Attach the installation plate to the wall following the measurements and marks. Use the type "A" screws that are factory-supplied with the plate. If mounting the unit on a concrete wall, use field-supplied anchor bolts.
- Observe all rear piping clearances when drilling into the wall.

⚠ WARNING

- When choosing a location for the wall mount plate, be sure to take into consideration routing of wiring for power outlets within the wall. Contacting wiring can cause serious bodily injury or death.
- Use caution when drilling holes through the walls for the purposes of piping connections. Power wiring can cause serious bodily injury or death.

Note:

Select the location carefully. Unit must be anchored to a strong and solid wall to prevent unnecessary vibration.

Figure 13: Wall Mount Indoor Unit Installation Plates.

LSN090-120HSV5 Installation Plate

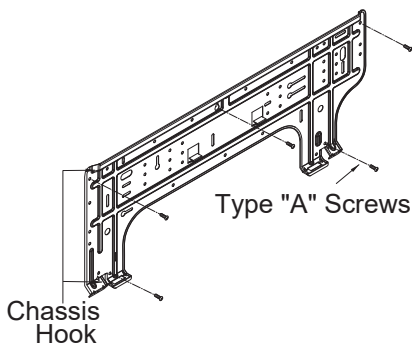

LSN181HSV5 Installation Plate

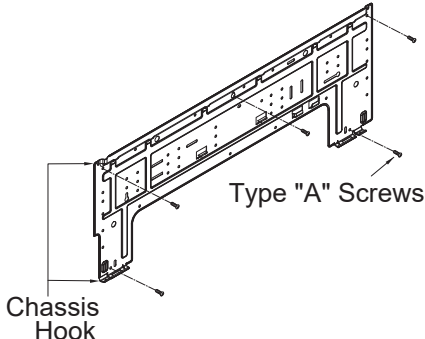
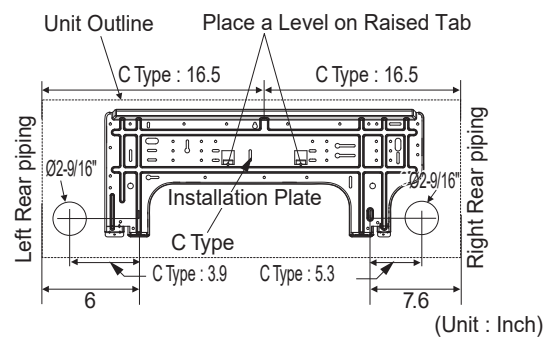
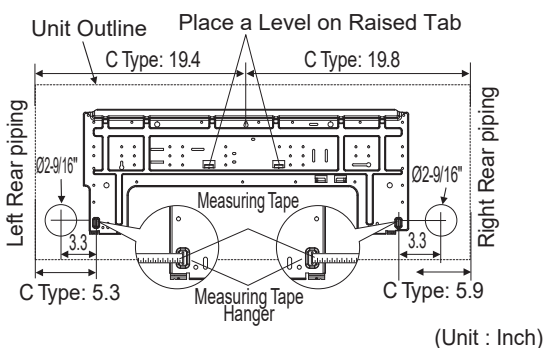

Figure 14: Wall Mount Indoor Unit Installation Plate Dimensions.

LSN090-120HSV5 Installation Plate



LSN181HSV5 Installation Plate



GENERAL INSTALLATION GUIDELINES

Indoor Unit Mounting

Removing the Indoor Unit Bottom Cover

To access the indoor unit piping port connections, terminal block, and to make the indoor unit installation procedure easier, it is recommended that the bottom cover be removed first.

1. Unsnap the bottom cover at its top left and right sides (Location 1).
2. Unsnap each of the three (3) or four (4) small C-hooks located in the middle of the bottom cover (Location 2). Number of C-hooks present depends on model of indoor unit.
3. Lift the three (3) to four (4) hinges on the bottom cover up and out of the channels molded to the left, right, and middle of the indoor unit (Location 3). Number of hinges present depends on model of indoor unit.
4. Set aside the bottom cover to re-install after all procedures are complete.

Figure 15: Indoor Unit with the Bottom Cover On (Bottom View; Appearances Will Vary Depending on Indoor Unit Model).



Figure 16: Steps to Removing the Bottom Cover.

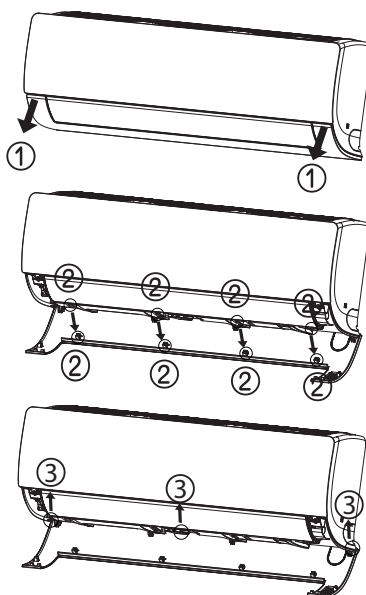

Figure 17: Removing the Bottom Cover (Appearances Will Vary Depending on Indoor Unit Model).



Figure 18: Bottom Cover with Top and Middle Unsnapped, Front View (Appearances Will Vary Depending on Indoor Unit Model).

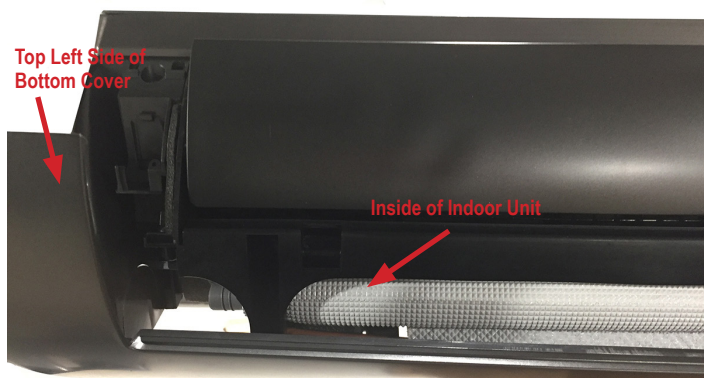

Figure 19: Back of Bottom Cover Completely Removed from Indoor Unit (Appearances Will Vary Depending on Indoor Unit Model).

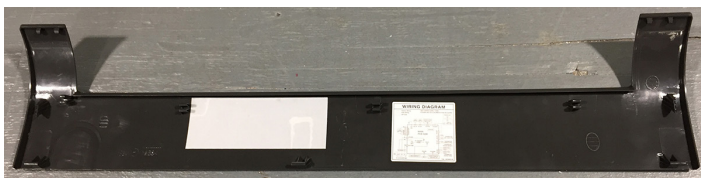
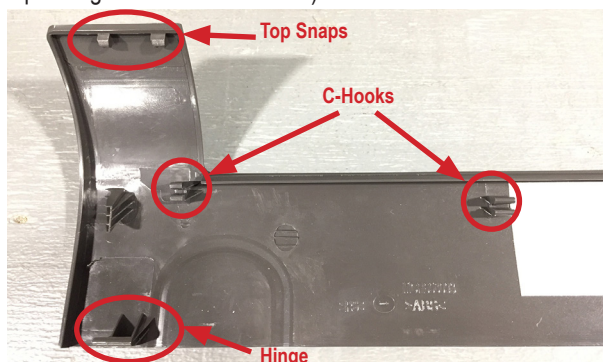

Figure 20: Close Up of Bottom Cover Connections (Appearances Will Vary Depending on Indoor Unit Model).



GENERAL INSTALLATION GUIDELINES

Indoor Unit Mounting

Mounting the Indoor Unit to the Installation Plate

1. Position the indoor unit onto the upper portion of the installation plate.
2. Engage the hooks at the top of the indoor unit with the upper edge of the installation plate (number of hooks depends on model type).
3. Ensure the hooks are properly seated on the installation plate by shaking the indoor unit left and right.

Figure 21: Attaching the Indoor Unit to the Installation Plate.

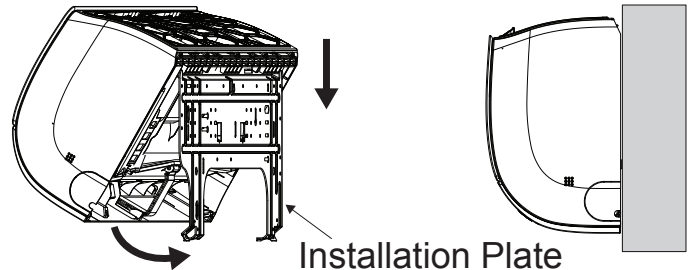

Note:

Permanently secure the indoor unit to the wall **ONLY AFTER** all other tasks such as Refrigerant Piping Connections, Drain Piping Connections, Electrical Connections, and Final Installation Procedures are complete. See next page for steps on how to prepare for piping and electrical connections.

Figure 22: Finishing Indoor Unit Installation to the Wall Plate.

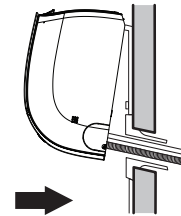

4. Carefully guide the refrigerant piping and drain piping through the access hole.
5. Push the bottom of indoor unit towards the installation plate to anchor to the wall.
 - Press the lower left and right sides of the unit against the installation plate until the hooks engage into their slots.
 - A clicking sound will be heard as the bottom of the indoor unit attaches to the installation plate successfully.
 - Pay attention to the positioning of the piping through the wall.

6. Finish the installation by completely securing the indoor unit to the installation plate using the factory-supplied two Type “C” screws at the locations indicated at right.

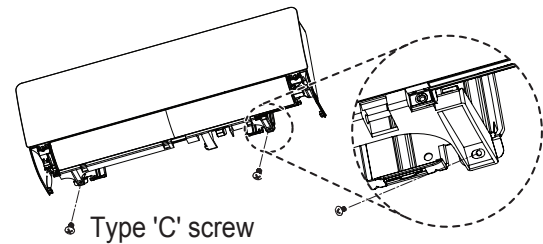

⚠ WARNING

The indoor unit can fall from the wall if it is not properly installed and secured to the installation plate. Falling indoor units can cause bodily injury or death.

Note:

- To avoid a gap between the indoor unit and the wall, ensure the screws are correctly and fully secured to the installation plate.
- To prevent condensate from forming due to an inflow of outdoor air, before indoor unit installation is finished, completely seal the piping access hole in the wall.

GENERAL INSTALLATION GUIDELINES

Indoor Unit Mounting

Preparing for Piping / Electrical Connections

1. To prepare the indoor unit for piping and electrical installation, disengage bottom on indoor unit from installation plate by reversing Steps 6, 5, and 4 from the previous procedure, if those procedures have been performed.
2. Unsnap the piping / drain hose holder (L-bracket) out from the indoor unit chassis. Prop it open between the indoor unit chassis and installation plate to separate the bottom of the indoor unit from the wall. This will allow for more working space.

Figure 23: Mounting the Indoor Unit on Installation Plate.

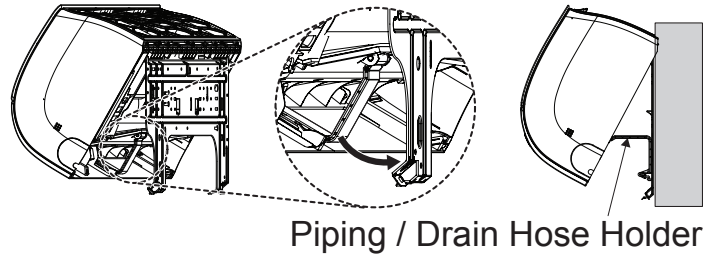

Figure 24: L-bracket Closed (Appearances Will Vary Depending on Indoor Unit Model).

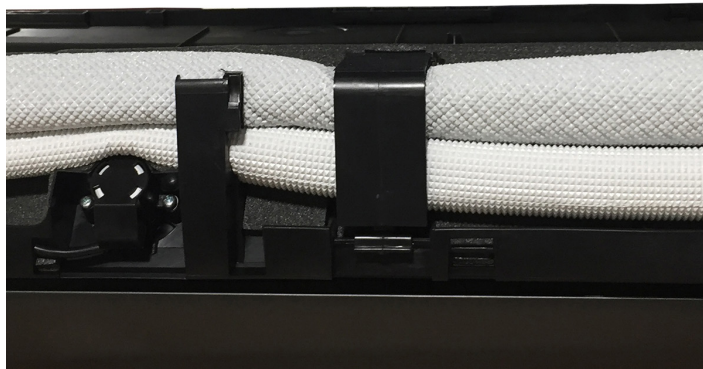

Figure 25: L-bracket Open (Appearances Will Vary Depending on Indoor Unit Model).



Note:

- Go to the *Refrigerant Piping Connections* section of this manual for information on indoor unit piping connection installation. See also the *Refrigerant Piping Connections* section for drain piping installation.
- Go to the *Electrical Installation* section of this manual for information on electrical wiring to the indoor unit.
- After all *Refrigerant Piping and Electrical Connection* procedures are complete, snap the L-bracket closed, and secure the indoor unit to the installation plate as detailed in Steps 5 and 6 in “Mounting the Indoor Unit to the Installation Plate”.

REFRIGERANT SAFETY STANDARDS / DEVICE CONNECTION LIMITATIONS

Refrigerant Safety Standards

ASHRAE Standards 15-2010 and 34-2010 address refrigerant safety and the maximum allowable concentration of refrigerant in an occupied space. Refrigerant will dissipate into the atmosphere, but a certain volume of air is required to safely dissipate the refrigerant. For R410A refrigerant, the maximum allowable concentration of refrigerant is 26 lbs./1,000 cubic feet (Addendum L modified the RCL to 26) of occupied spaces. Buildings with 24-hour occupancy are allowed half of that concentration.

If a single zone system develops a refrigerant leak, the entire refrigerant charge of the system will dump into the area where the leak occurs. To meet ASHRAE Standards 15 and 34, the smallest room volume on the system must be calculated and compared to the maximum allowable concentration. Also consult state and local codes in regards to refrigerant safety.

Device Connection Limitations

A single-zone system consists of one outdoor unit and one indoor unit. One of the most critical elements of a single-zone system is the refrigerant piping. If the connection piping is not within allowable limits, there will be reliability, performance, noise, and vibration issues. The table below lists pipe length limits that must be followed in the design of a Single Zone High Efficiency Wall Mount refrigerant pipe system. Refer to the figure for maximum length and elevation of piping.

Figure 26: Single Zone High Efficiency Wall Mount System Layout.

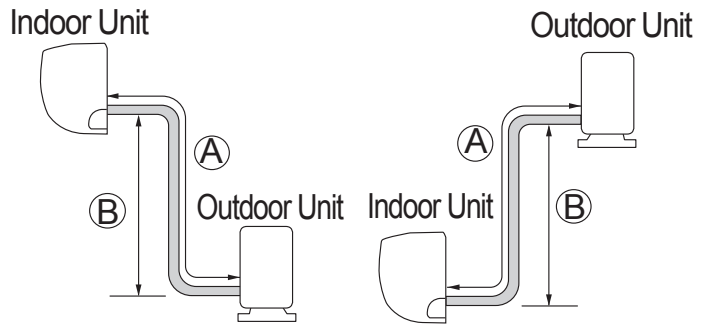

Table 7: Single Zone High Efficiency Refrigerant Piping System Limitations.

Model Numbers		LS090HSV5 (LSN090HSV5/ LSU090HSV5)	LS120HSV5 (LSN120HSV5/ LSU120HSV5)	LS181HSV5 (LSN181HSV5/ LSU181HSV5)
Pipe Sizes	Vapor	Ø3/8	Ø3/8	Ø5/8
	Liquid	Ø1/4	Ø1/4	Ø3/8
Pipe Length (ELF = Equivalent Length of pipe in Feet)	Standard Piping Length	24.6	24.6	24.6
	Piping Length with No Additional Refrigerant	41	41	24.6
	Longest total equivalent piping length	82	82	114.8
	Shortest total equivalent piping length	9.8	9.8	9.8
	Distance between fittings and indoor units or outdoor units	≥20 inches	≥20 inches	≥20 inches
Elevation (All Elevation Limitations are Measured in Actual Feet)	If outdoor unit is above indoor unit	49.2	49.2	49.2
	If outdoor unit is below indoor unit	49.2	49.2	49.2
Additional Refrigerant Needed (oz/ft)		0.22	0.22	0.38

SELECTING FIELD SUPPLIED PIPING

Selecting Field-Supplied Copper Piping

Note:

Always follow local codes when selecting and installing copper pipe and piping system components.

Approved piping for use with LG Single Zone products will be marked “R410 RATED” along the length of the pipe. Piping wall thickness must meet local code requirements and be approved for a maximum operating pressure of 551 psi. When bending piping, try to keep the number of bends to a minimum, and use the largest radii possible to reduce the equivalent length of installed piping; also, bending radii greater than ten (10) piping diameters can minimize pressure drop. Be sure no traps or sags are present.

For Single Zone Systems

LG prefers the use of ACR copper piping rated at the system working pressure was used.

Note:

Always properly support the piping as per the instructions in the Refrigerant System Engineering section.

Table 9: ACR Rated Copper Tubing Material.

Type	Seamless Phosphorous Deoxidized
Class	UNS C12200 DHP
Straight Lengths	H58 Temper
Coils	O60 Temper

Table 8: Piping Tube Thicknesses.

OD (in)	1/4	3/8	1/2	5/8	3/4	7/8	1-1/8	1-3/8	1-5/8
Material	Rigid or Soft ACR Rated for R410A				Rigid or Solid ACR Rated for R410A				
Min. Bend Radius (in)	0.563	0.9375	1.5	2.25	3.0	3.0	3.5	4.0	4.5
Min. Wall Thickness (in)	0.03	0.03	0.03	0.03	0.03	0.03	0.03	0.04	0.050

Table 10: ACR Copper Tubing Dimensions and Physical Characteristics¹⁻³.

Nominal Pipe Outside Diameter (in)	Actual Outside Diameter (in)	Drawn Temper			Annealed Temper		
		Nominal Wall Thickness (in)	Weight (lb/ft)	Cubic ft per Linear ft	Nominal Wall Thickness (in)	Weight (lb/ft)	Cubic ft per Linear ft
1/4	0.250	--	--	--	0.030	0.081	0.00020
3/8	0.375	0.030	0.126	0.00054	0.032	0.134	0.00053
1/2	0.500	0.035	0.198	0.00101	0.032	0.182	0.00103
5/8	0.625	0.040	0.285	0.00162	0.035	0.251	0.00168
3/4	0.750	0.042	0.362	0.00242	0.042	0.362	0.00242
7/8	0.875	0.045	0.455	0.00336	0.045	0.455	0.00336
1-1/8	1.125	0.050	0.655	0.00573	0.050	0.655	0.00573

¹All dimensions provided are in accordance with ASTM B280 – Standard..

²Design pressure = 551 psig.

³The Copper Tube Handbook, 2010, Copper Development Association Inc., 260 Madison Avenue, New York, NY 10016.

Note:

- Commercially available piping often contains dust and other materials. Always blow it clean with a dry inert gas.
- Prevent dust, water or other contaminants from entering the piping during installation.

COPPER EXPANSION AND CONTRACTION

Copper Expansion and Contraction

Under normal operating conditions, the vapor pipe temperature of a Duct Free System can vary as much as 280°F. With this large variance in pipe temperature, the designer must consider pipe expansion and contraction to avoid pipe and fitting fatigue failures.

Refrigerant pipe along with the insulation jacket form a cohesive unit that expands and contracts together. During system operation, thermal heat transfer occurs between the pipe and the surrounding insulation.

If the pipe is mounted in free air space, no natural restriction to movement is present if mounting clamps are properly spaced and installed. When the refrigerant pipe is mounted underground in a utility duct stacked among other pipes, natural restriction to linear movement is present. In extreme cases, the restrictive force of surface friction between insulating jackets could become so great that natural expansion ceases and the pipe is “fixed” in place. In this situation, opposing force caused by change in refrigerant fluid/vapor temperature can lead to pipe/fitting stress failure.

The refrigerant pipe support system must be engineered to allow free expansion to occur. When a segment of pipe is mounted between two fixed points, provisions must be provided to allow pipe expansion to naturally occur. The most common method is the inclusion of expansion Loop or U-bends. Each segment of pipe has a natural fixed point where no movement occurs. This fixed point is located at the center point of the segment assuming the entire pipe is insulated in a similar fashion. The natural fixed point of the pipe segment is typically where the expansion Loop or U-bend must be. Linear pipe expansion can be calculated using the following formula:

$$LE = C \times L \times (T_r - T_a) \times 12$$

LE	=	Anticipated linear tubing expansion (in.)
C	=	Constant (For copper = 9.2×10^{-6} in./in.°F)
L	=	Length of pipe (ft.)
T_r	=	Refrigerant pipe temperature (°F)
T_a	=	Ambient air temperature (°F)
12	=	Inches to feet conversion (12 in./ft.)

See table on next page for precalculated anticipated expansion for various pipe sizes and lengths of refrigerant tubing.

To find the anticipated expansion value:

1. From the table on the next page, find the row corresponding with the actual feet of the straight pipe segment.
2. Estimate the minimum and maximum temperature of the pipe.
3. In the column showing the minimum pipe temperature, look up the anticipated expansion distance corresponding to the segment length. Do the same for the maximum pipe temperature.
4. Calculate the difference in the two expansion distance values. The result will be the change in pipe length.

1. From Table 11 find the row corresponding with the actual length of the straight pipe segment.
2. Estimate the minimum and maximum temperature of the pipe. In the column showing the minimum pipe temperature, look up the anticipated expansion distance. Do the same for the maximum pipe temperature.
3. Calculate the difference in the two expansion distance values. The result will be the anticipated change in pipe length.

General Example:

A system is installed and the design shows that there is a 100 foot straight segment of tubing between an indoor unit and the outdoor unit. In heating, this pipe transports hot gas vapor to the indoor units at 120 °F. In cooling, the same tube is a suction line returning refrigerant vapor to the outdoor unit at 40 °F. Look up the copper tubing expansion at each temperature and calculate the difference.

Vapor Line

Transporting Hot Vapor: 100 ft. pipe at 120 °F = 1.40 in.

Transporting Suction Vapor: 100 ft. pipe at 40 °F = 0.40 in.

Anticipated Change in Length: 1.40 in. – 0.40 in. = 1.00 in.

Liquid Line

The liquid temperature remains relatively the same temperature; only the direction of flow will reverse. Therefore, no significant change in length of the liquid line is anticipated.

When creating an expansion joint, the joint height must be a minimum of two times the joint width. Although different types of expansion arrangements are available, the data for correctly sizing an Expansion Loop is provided in Table 12. Use soft copper with long radius bends on longer runs or long radius elbows for shorter pipe segments. Using the anticipated linear expansion (LE) distance calculated, look up the Expansion Loop or U-bend minimum design dimensions. If other types of expansion joints are chosen, design per ASTM B-88 Standards.

COPPER EXPANSION AND CONTRACTION

Table 11: Linear Thermal Expansion of Copper Tubing in Inches.

Pipe Length ¹	Fluid Temperature °F																			
	35°	40°	45°	50°	55°	60°	65°	70°	75°	80°	85°	90°	95°	100°	105°	110°	115°	120°	125°	130°
10	0.04	0.04	0.05	0.06	0.06	0.07	0.08	0.08	0.09	0.09	0.10	0.10	0.11	0.11	0.11	0.12	0.13	0.14	0.15	0.15
20	0.08	0.08	0.10	0.12	0.13	0.14	0.15	0.16	0.17	0.18	0.19	0.20	0.21	0.22	0.22	0.23	0.26	0.28	0.29	0.30
30	0.12	0.12	0.15	0.18	0.20	0.21	0.23	0.24	0.26	0.27	0.29	0.30	0.32	0.33	0.32	0.35	0.39	0.42	0.44	0.45
40	0.16	0.16	0.20	0.24	0.26	0.28	0.30	0.32	0.34	0.36	0.38	0.40	0.42	0.44	0.43	0.46	0.52	0.56	0.58	0.60
50	0.20	0.20	0.25	0.30	0.33	0.35	0.38	0.40	0.43	0.45	0.48	0.50	0.53	0.55	0.54	0.58	0.65	0.70	0.73	0.75
60	0.24	0.24	0.30	0.36	0.39	0.42	0.45	0.48	0.51	0.54	0.57	0.60	0.63	0.66	0.65	0.69	0.78	0.84	0.87	0.90
70	0.28	0.28	0.35	0.42	0.46	0.49	0.53	0.56	0.60	0.63	0.67	0.70	0.74	0.77	0.76	0.81	0.91	0.98	1.02	1.05
80	0.32	0.32	0.40	0.48	0.52	0.56	0.60	0.64	0.68	0.72	0.76	0.80	0.84	0.88	0.86	0.92	1.04	1.12	1.16	1.20
90	0.36	0.36	0.45	0.54	0.59	0.63	0.68	0.72	0.77	0.81	0.86	0.90	0.95	0.99	0.97	1.04	1.17	1.26	1.31	1.35
100	0.40	0.40	0.50	0.60	0.65	0.70	0.75	0.80	0.85	0.90	0.95	1.00	1.05	1.10	1.08	1.15	1.30	1.40	1.45	1.50
120	0.48	0.48	0.60	0.72	0.78	0.84	0.90	0.96	1.02	1.08	1.14	1.20	1.26	1.32	1.30	1.38	1.56	1.68	1.74	1.80
140	0.56	0.56	0.70	0.84	0.91	0.98	1.05	1.12	1.19	1.26	1.33	1.40	1.47	1.54	1.51	1.61	1.82	1.96	2.03	2.10
160	0.64	0.64	0.80	0.96	1.04	1.12	1.20	1.28	1.36	1.44	1.52	1.60	1.68	1.76	1.73	1.84	2.08	2.24	2.32	2.40
180	0.72	0.72	0.90	1.08	1.17	1.26	1.35	1.44	1.53	1.62	1.71	1.80	1.89	1.98	1.94	2.07	2.34	2.52	2.61	2.70

¹Pipe length baseline temperature = 0°F. "Expansion of Carbon, Copper and Stainless Steel Pipe," *The Engineers' Toolbox*, www.engineeringtoolbox.com.

Figure 27: Coiled Expansion Loops and Offsets (Plan View).

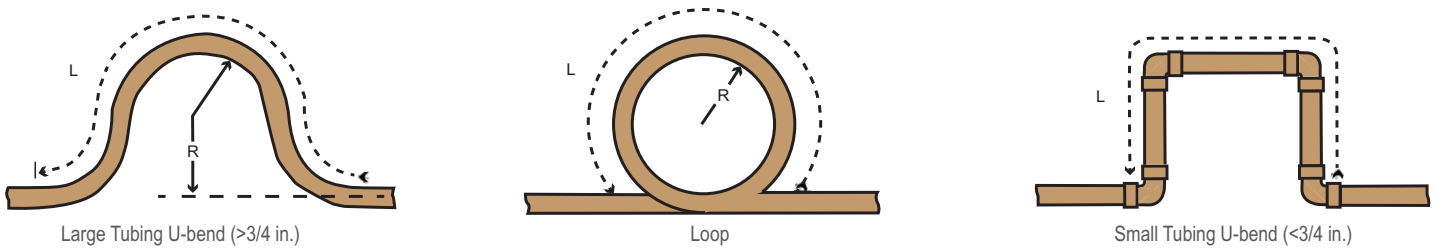

Note:

All expansion loops and offsets must be installed in the horizontal plane to prevent the possibility of trapping oil. Loops and offsets in vertical risers must also be installed in a horizontal plane.

Table 12: Radii of Coiled Expansion Loops and Developed Lengths of Expansion Offsets.

Anticipated Linear Expansion (LE) (inches)		Nominal Tube Size (OD) inches			
		1/4	3/8	1/2	3/4
1/2	R ¹	6	7	8	9
	L ²	38	44	50	59
1	R ¹	9	10	11	13
	L ²	54	63	70	83
1-1/2	R ¹	11	12	14	16
	L ²	66	77	86	101
2	R ¹	12	14	16	19
	L ²	77	89	99	117
2-1/2	R ¹	14	16	18	21
	L ²	86	99	111	131
3	R ¹	15	17	19	23
	L ²	94	109	122	143
3-1/2	R ¹	16	19	21	25
	L ²	102	117	131	155
4	R ¹	17	20	22	26
	L ²	109	126	140	166

¹R = Centerline Length of Pipe.

²L = Centerline Minimum Radius (inches).

Piping Materials and Handling



Pipes used for the refrigerant piping system must include the specified thickness, and the interior must be clean.

While handling and storing,  do not bend or damage the pipes, and take care not to contaminate the interior with dust, moisture, etc.

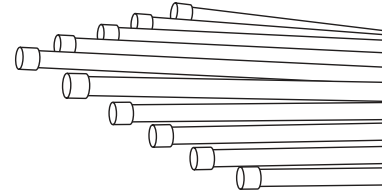
Keep Pipes Capped While Storing.

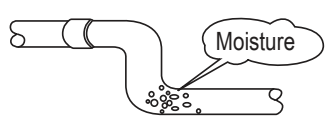
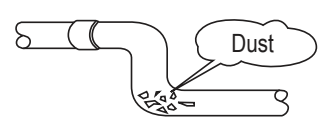
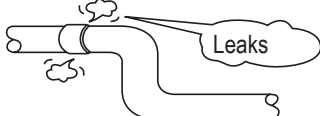

Keep refrigerant pipe dry, clean, and airtight.

	Dry	Clean	Airtight
	No moisture should be inside the piping.	No dust should be inside the piping.	No leaks should occur.
			
Possible Problems	<ul style="list-style-type: none"> - Significant hydrolysis of refrigerant oil. - Refrigerant oil degradation. - Poor insulation of the compressor. - System does not operate properly. - EEVs, capillary tubes are clogged. 	<ul style="list-style-type: none"> - Refrigerant oil degradation. - Poor insulation of the compressor. - System does not operate properly. - EEVs and capillary tubes become clogged. 	<ul style="list-style-type: none"> - Refrigerant gas leaks / shortages. - Refrigerant oil degradation. - Poor insulation of the compressor. - System does not operate properly.
Solutions	<ul style="list-style-type: none"> - Remove moisture from the piping. - Piping ends should remain capped until connections are complete. -  Do not install piping on a rainy day. - Connect piping properly at the unit's side. - Remove caps only after the piping is cut, the burrs are removed, and after passing the piping through the walls. - Evacuate system to a minimum of 500 microns and insure the vacuum holds at that level for 24 hours 	<ul style="list-style-type: none"> - Remove dust from the piping. - Piping ends should remain capped until connections are complete. - Connect piping properly at the side of the unit. - Remove caps only after the piping is cut and burrs are removed. - Retain the cap on the piping when passing it through walls, etc. 	<ul style="list-style-type: none"> - Test system for air tightness. - Perform brazing procedures that comply with all applicable standards. - Perform flaring procedures that comply with all applicable standards. - Perform flanging procedures that comply with all applicable standards. - Ensure that refrigerant lines are pressure tested to 550 psig and hold for 24 hours.

REFRIGERANT SYSTEM ENGINEERING

Proper system operation depends on the installer using utmost care while assembling the piping system. The following pages are an overview of best practices when installing the refrigerant piping system.

Note:

LG Electronics U.S.A., Inc., is not responsible for any piping calculations, refrigerant leaks, degradation of performance, any other potential problems or damages caused by the interconnecting piping, their joint connections, isolation valves, or introduced debris inside the piping system.

⊘ No Pipe Size Substitutions

Use only the pipe size selected by the information in this manual. Using a different size is prohibited and will result in a system malfunction or failure to work at all.

⊘ No In-line Refrigeration Components

Components such as oil traps, solenoid valves, filter-driers, sight glasses, tee fittings, and other after-market accessories are ⊘ not permitted on the refrigerant piping system between the outdoor units and the indoor units. LG Single Zone systems are provided with redundant systems that make sure oil is properly returned to the compressor. Sight-glasses and solenoid valves will cause vapor to form in the liquid stream. Over time, driers will deteriorate and introduce debris into the system. The designer and installer must verify the refrigerant piping system is free of traps, sagging pipes, sight glasses, filter driers, etc.

Field-Provided Isolation Ball Valves

LG maintains a neutral position on using isolation valves in LG HVAC refrigerant piping systems. LG does not endorse any manufacturer of isolation valves. It is recognized that installing isolation valves will simplify future maintenance requirements, and, if used, considerations must be taken including, but not limited to, the following:

- Pressure drops for any component used, including isolation valves, must be known in equivalent pipe length and calculated into the total and segment equivalent piping lengths and compared to product design limitations.
- In all cases, materials must be suitable for the application and any applicable codes, including, but not limited to, diameter and wall thickness continuity per ACR standards.

Failure to do so will cause significant performance degradation. Proper leak checks must be performed. Using isolation valves does not automatically void any LG product warranty, however, a limited warranty will be voided in whole or part if any field supplied accessory fail in any way that causes product failure.

Using Elbows

Field-supplied elbows are allowed if they are long radius and designed for use with R410A refrigerant. The designer and installer, however, must be cautious with the quantity and size of fittings used, and must account for the additional pressure losses in equivalent pipe length calculation for each branch. The equivalent pipe length of each elbow must be added to each pipe segment manually (see table).

Table 13: Equivalent Piping Length for Elbows.

Elbow (ft.)	1/4	3/8	1/2	5/8	3/4
	0.5	0.6	0.7	0.8	1.2

Pipe Bends

When bending soft copper, use long radius bends. Refer to the “Radii of Coiled Expansion Loops and Developed Lengths of Expansion Offsets” table for minimum radius specifications.

REFRIGERANT SYSTEM ENGINEERING

Obstacles

When an obstacle, such as an I-beam or concrete T, is in the path of the planned refrigerant pipe run, it is best practice to route the pipe over the obstacle. If adequate space is not available to route the insulated pipe over the obstacle, then route the pipe under the obstacle. In either case, it is imperative the length of the horizontal section of pipe above or below the obstacle be a minimum of three (3) times the longest vertical rise (or fall) at either end of the segment.

Figure 28: Installing Piping Above and Below an Obstacle.

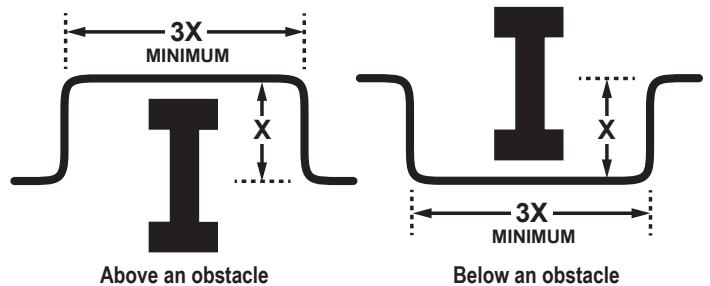

Pipe Supports

A properly installed pipe system must be adequately supported to avoid pipe sagging. Sagging pipes become oil traps that lead to equipment malfunction.

Pipe supports must  never touch the pipe wall; supports must be installed outside (around) the primary pipe insulation jacket. Insulate the pipe first because pipe supports must be installed outside (around) the primary pipe insulation jacket. Clevis hangers must be used with shields between the hangers and insulation. Field provided pipe supports must be designed to meet local codes. If allowed by code, use fiber straps or split-ring hangers suspended from the ceiling on all-thread rods (fiber straps or split ring hangers can be used as long as they do not compress the pipe insulation). Place a second layer of insulation over the pipe insulation jacket to prevent chafing and compression of the primary insulation within the confines of the support pipe clamp.

A properly installed pipe system will have sufficient supports to avoid pipes from sagging during the life of the system. As necessary, place supports closer for segments where potential sagging could occur. Maximum spacing of pipe supports must meet local codes. If local codes do not specify pipe support spacing, pipe must be supported:

- Maximum of five (5) feet on center for straight segments of pipe up to 3/4 inches outside diameter size.
- Maximum of six (6) feet on center for pipe up to one (1) inch outside diameter size.
- Maximum of eight (8) feet on center for pipe up to two (2) inches outside diameter size.

Wherever the pipe changes direction, place a hanger within twelve (12) inches on one side and within twelve (12) to nineteen (19) inches of the bend on the other side.

Figure 29: Pipe Hanger Details.

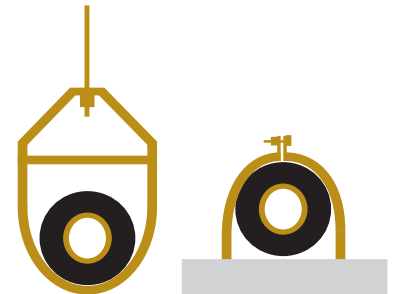

Note:

Use a 4" + long sheet curved sheet metal saddles between hanger bracket and insulation to promote linear expansion/contraction.

Figure 30: Typical Pipe Support Location—Change in Pipe Direction.

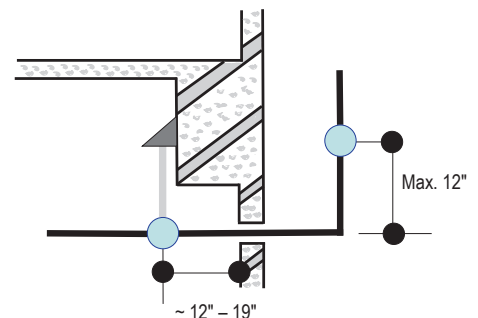

REFRIGERANT SYSTEM ENGINEERING

Pipe Sleeves at Penetrations

LG requires that all pipe penetrations through walls, floors, and pipes buried underground be properly insulated and routed through an appropriate wall sleeve of sufficient size to prevent compression of refrigerant pipe insulation and free movement of the pipe within the sleeve. Use 4" + curved sheet metal saddles between the bottom surface of the pipe and the bottom surface of the penetration.

Figure 31: Pipe Sleeve Options.

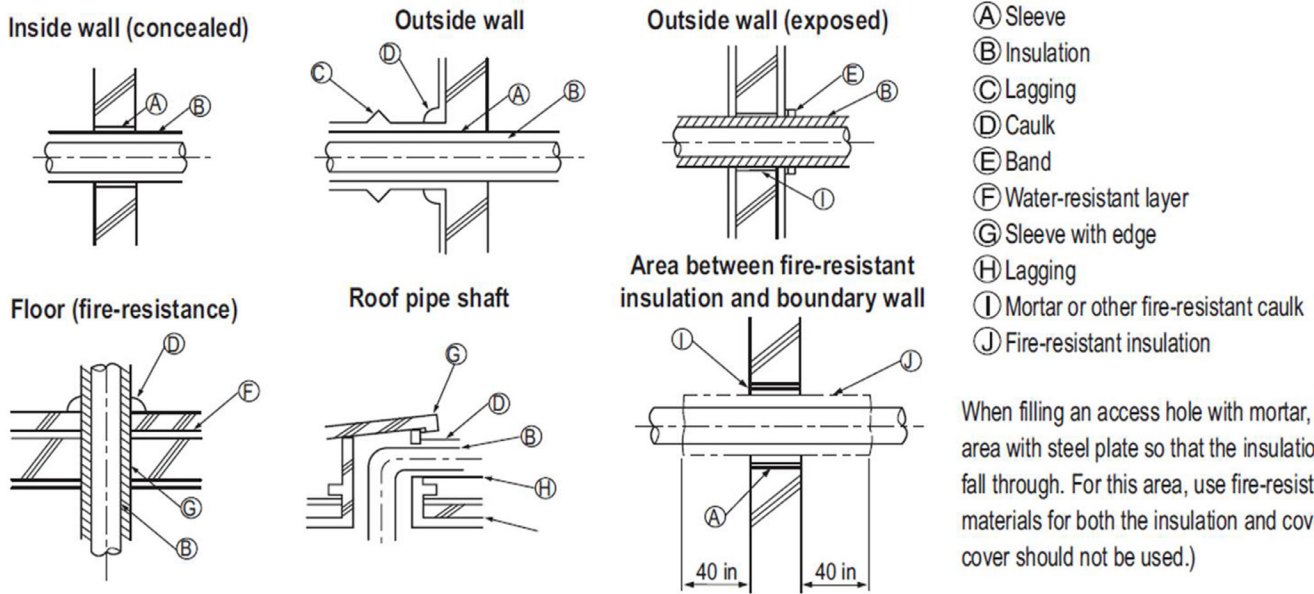

When filling an access hole with mortar, cover the area with steel plate so that the insulation will not fall through. For this area, use fire-resistant materials for both the insulation and cover. (Vinyl cover should not be used.)

Note:

Diameter of penetrations must be determined by pipe diameter plus the thickness of the insulation.

Underground Refrigerant Piping

Refrigerant pipe installed underground must be routed inside a vapor tight protective sleeve to prevent insulation deterioration and water infiltration. Refrigerant pipe installed inside underground casing must be continuous without any joints. Underground refrigerant pipe must be located at a level **below the frost line**.

Table 14: Utility Conduit Sizes.

Liquid Pipe ¹	Vapor Pipe ¹		
	1/2 (2.0 ^{2,5})	5/8 (2-1/8 ^{2,5})	3/4 (2-1/4 ^{2,5})
1/4 (1.0) ³	4	4	4
3/8 (1-1/8) ³	4	4	5
1/2 (1-1/2) ⁴	5	5	5
5/8 (1-5/8) ⁴	5	5	5
3/4 (1-3/4) ⁴	5	5	5

¹OD pipe diameter in inches; Values in parenthesis () indicate OD of pipe with insulation jacket.
²Diameter of pipe with insulation. Thickness of pipe insulation is typical. Actual required thickness will vary based on surrounding ambient conditions and must be calculated and specified by the design engineer.
³Insulation thickness (value in parenthesis) = 3/8 inch.
⁴Insulation thickness (value in parenthesis) = 1 inch.
⁵Insulation thickness (value in parenthesis) = 3/4 inch.

Figure 32: Typical Arrangement of Refrigerant Pipe and Cable(s) in a Utility Conduit.

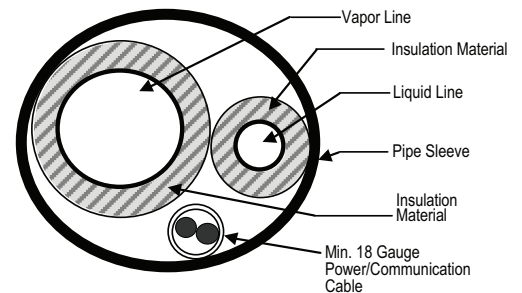

Table 15: Heat Pump Unit Refrigerant Pipe Connections (All Brazed Type).

Model	Liquid Conn. (inches)	Vapor Conn. (inches)
LSU090HSV5, LSU120HSV5	1/4	3/8
LS181HSV5	3/8	5/8

Note:

Provide expansion joints in long pipe segments and place in an accessible conduit box for inspection. Use galvanized curved sheet metal saddles at all mounting points. Pipe must be allowed to move freely linearly.

FLARING AND BRAZING PROCEDURES

Flaring and Brazing Procedures

One of the main causes of refrigerant leaks is a defective connection. For LG HVAC systems, the installer needs to know how perform both flared and brazed connections successfully.

Note:

- During installation, it is imperative to keep the piping system free of contaminants and debris such as copper burrs, slag, or carbon dust.
-  Do not use kinked pipe caused by excessive bending in one specific area on its length.

Flaring Procedure

Note:

When selecting flare fittings, always use a 45° fitting rated for use with high pressure refrigerant R410A. Selected fittings must also comply with local, state, or federal standards.

1. Cut the pipe to length.

- Measure the distance between the indoor unit and the outdoor unit.
- Cut the pipes a little longer than measured distance.

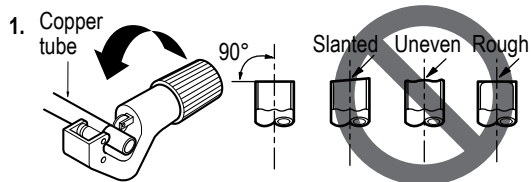

2A. Remove the burrs.

- Completely remove all burrs from pipe ends.
- When removing burrs, point the end of the copper pipe down to avoid introducing foreign materials in the pipe.

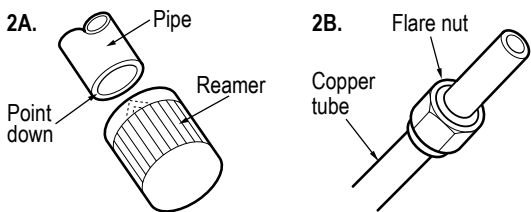

2B. Slide the flare nut onto the copper tube.

3. Flaring the pipe end.

- Use the proper size flaring tool to finish flared connections as shown.
- ALWAYS create a 45° flare when working with R410A.

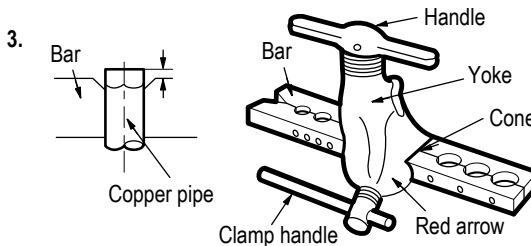

4. Carefully inspect the flared pipe end.

- Compare the geometry with the figure to the right
- If the flare is defective, cut it off and re-do procedure.
- If flare looks good, blow the pipe clean with dry nitrogen.

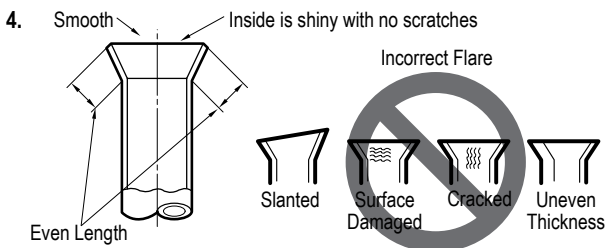

Dimensions of the Flare.

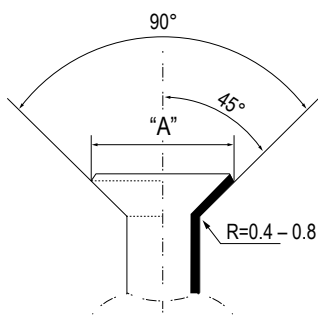

Flared Connection Dimensions / Tightening Torque.

Pipe Size (in. O.D.)	Outside Diameter (mm)	"A" Dimension (mm [in.])
1/4	6.35	~ 9.1 (11/32 - 23/64)
3/8	9.52	~ 13.2 (1/2 - 33/64)
1/2	12.7	~ 16.6 (41/64 - 21/32)
5/8	15.88	~ 19.7 (49/64 - 25/32)
3/4	19.05	-

FLARING AND BRAZING PROCEDURES

Tightening the Flare Nuts

Tightening Torque for Flare Nuts.

Pipe Size (in. O.D.)	Outside Diameter (mm)	Tightening Torque (ft-lbs.)
1/4	6.35	13.0 - 18.0
3/8	9.52	24.6 - 30.4
1/2	12.7	39.8 - 47.7
5/8	15.88	45.4 - 59.3
3/4	19.05	71.5 - 87.5

1. When connecting the flare nuts, coat the flare (outside only) with polyvinyl ether (PVE) refrigeration oil only.

Note:

- ⊘ Do not use polyolyester (POE) or any other type of mineral oil as a thread lubricant. These lubricants are not compatible with the PVE oil used in this system and create oil sludge leading to equipment damage and system malfunction.
- ⊘ Do not add any contaminants inside the refrigerant piping.

2. Initially hand tighten the flare nuts using three (3) or four (4) turns.
3. To finish tightening the flare nuts, use both a torque wrench and a backup wrench.
4. After all the piping has been connected and the caps have been tightened, check for refrigerant gas leaks.

Loosening the Flare Nuts

Always use two (2) wrenches to loosen the flare nuts.

Brazing Practices

⚠ WARNING

- ⊘ Do not braze in an enclosed location. ⊘ Do not allow the refrigerant to leak during brazing. Always test for gas leaks before and after brazing.

If the refrigerant combusts, it generates a toxic gas the will cause physical injury or death.

1. Joints are brazed in the field. Single Zone refrigeration system components contain very small capillary tubes, small orifices, electronic expansion valves, oil separators, and heat exchangers that can easily become blocked. Proper system operation depends on the installer using best practices and utmost care while assembling the piping system.
2. Store pipe stock in a dry place; keep stored pipe capped and clean.
3. Blow clean all pipe sections with dry nitrogen prior to assembly.
4. Always use a non-oxidizing material for brazing. ⊘ Do not use flux, soft solder, or anti-oxidant agents. If the proper material is not used, oxidized film will accumulate and clog or damage the compressors. Flux can harm the copper piping or refrigerant oil.
5. Use a tubing cutter, ⊘ do not use a saw to cut pipe. De-bur and clean all cuts before assembly.
6. Brazing joints:
 - Use a dry nitrogen purge operating at a minimum pressure of three (3) psig and maintain a steady flow.
 - Use a 15% silver phosphorous copper brazing alloy to avoid overheating and produce good flow.
 - Protect isolation valves, electronic expansion valves, and other heat-sensitive control components from excessive heat with a wet rag or heat barrier spray.

Figure 33: Refrigerant Pipe Brazing.

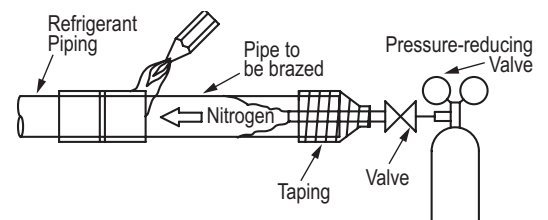

⚠ WARNING

- ⊘ Do not allow the refrigerant to leak during brazing; if the refrigerant combusts, it generates a toxic gas. There is risk of fire, explosion, and physical injury or death.
- ⊘ Do not braze in an enclosed location, and always test for gas leaks before / after brazing. There is risk of fire, explosion, and physical injury or death.

REFRIGERANT PIPING CONNECTIONS

Installation Overview

Installation

Single Zone Wall-Mounted systems are one-to-one systems. There is a direct piping connection between the outdoor unit and the indoor unit. The figure at right illustrates the basic pipe connections between the outdoor and indoor unit. Refer to the illustration when proceeding with pipe connections.

The illustration shows the indoor unit being installed at a higher position than the outdoor unit. However, if the outdoor unit be installed at a higher position than the indoor unit, the basic pipe connections are the same.

Refer to the “Connection Limitations” section for specific length limitations in conjunction with outdoor unit and indoor unit positioning.

Note:

- When proceeding with piping connections, adhere to pipe support spacing lengths as shown in the General Refrigerant Piping System Information section. Refer to the “Pipe Supports” section for information on using clamps and pipe support materials.
- Always adhere to local codes regarding piping and accurate support spacing along the piping system.
- Always include insulation on all refrigerant and drain piping to ensure condensate does not form and cause damage to walls, floors, etc.

Figure 34: Installation and Piping Connection Overview.

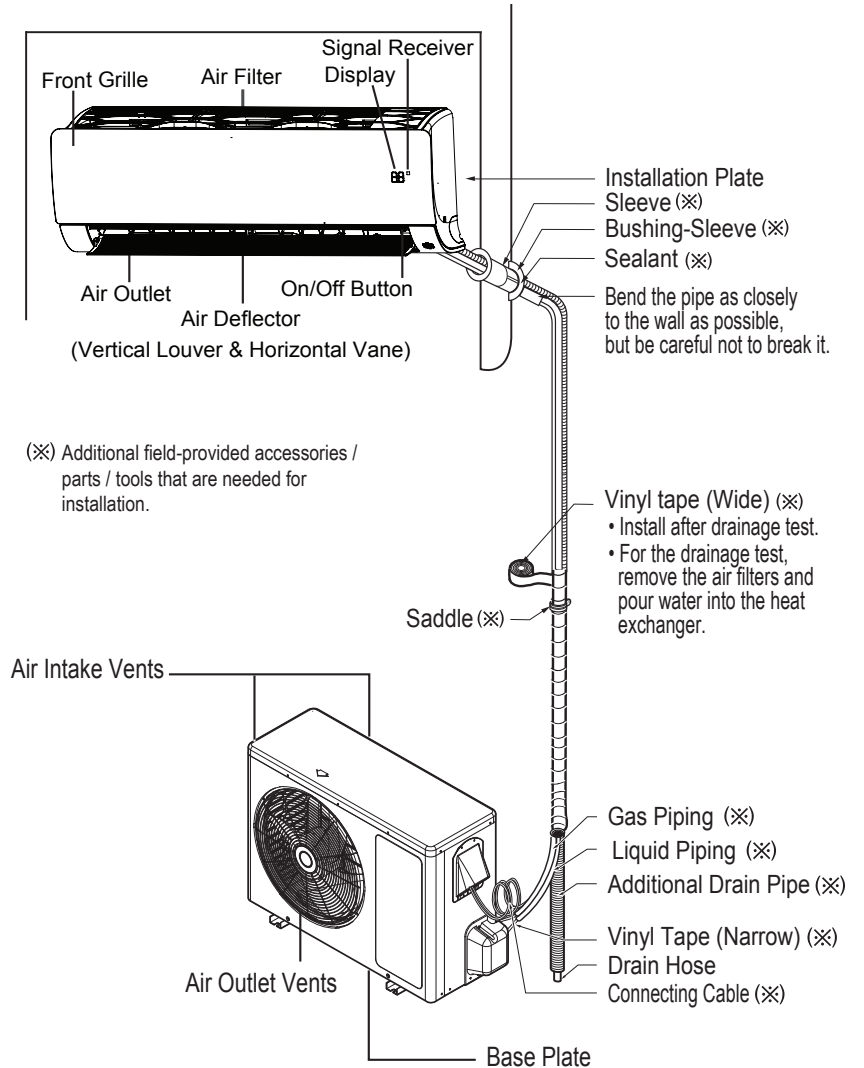

REFRIGERANT PIPING CONNECTIONS

Special Applications

Special Applications

If an additional drain hose is necessary, the end of drain outlet must be routed above the ground. Secure the drain hose appropriately.

When the Outdoor Unit is Installed Below the Indoor Unit:

1. Use a conduit, piping set cover, or bundle the (separately) insulated refrigerant piping, the drain hose, and the communications / connection (power) cable together.
2. Make sure to include some slack in the wiring. Wiring must be installed in an upwards direction to prevent water from accessing into the control box.
3. Secure the conduit, piping set cover, or bundle along the outside wall using saddles or a similar type of piping support.
4. Seal any openings in the wall that are around the piping.

When the Outdoor Unit is Installed Above the Indoor Unit:

1. Use a conduit, piping set cover, or bundle the (separately) insulated refrigerant piping and the communications / connection (power) cable together up to the outdoor unit service valves.
2. Make sure to include some slack in the wiring. Wiring must be installed in upwards direction to prevent water from traveling into the control box.
3. If necessary, secure the conduit, piping set cover, or bundle along the outside wall using saddles or a similar type of piping support.
4. Ensure the insulated drain hose from the indoor unit is installed away from the outdoor unit, and in a downwards direction. If necessary, secure along the outside wall using saddles or a similar type of support.
5. Seal any openings in the wall that are around the piping.

Figure 35: Special Applications.

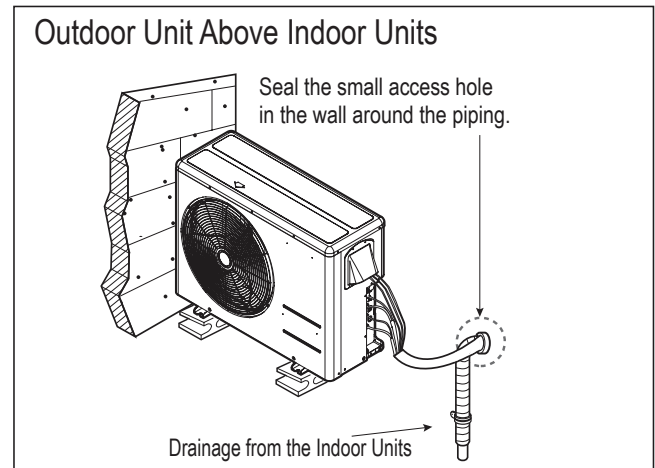
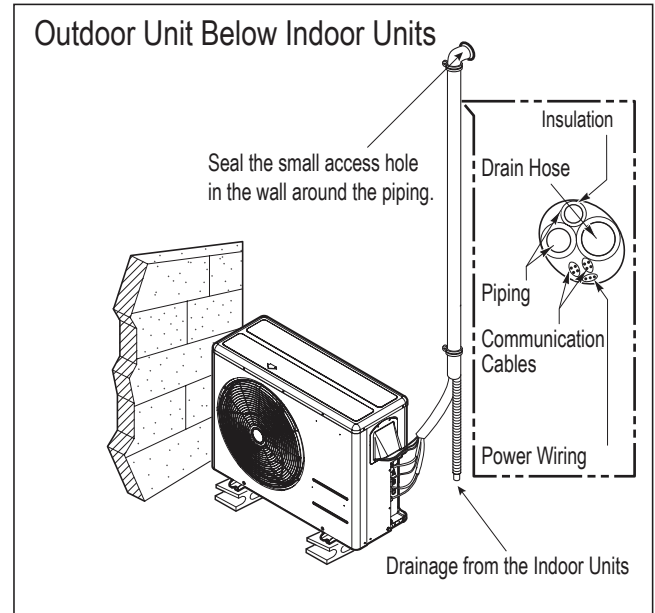

REFRIGERANT PIPING CONNECTIONS

Outdoor Unit Connections

Outdoor Unit Connections

1. Remove the piping cover or piping / control box cover (configuration depends on outdoor unit model) from the unit by loosening the fastening screws.
2. Align the center of the refrigerant piping and corresponding connection as shown.
3. Refer to the figures at right for liquid and gas (vapor) piping attachments onto the outdoor unit.
4. Place a couple of drops of PVE refrigerant oil on outside of the flare before assembling. ⚠ Do not add any contaminants. Tighten the flare nut initially by hand.
5. Finish tightening the flare nut with a torque wrench until the wrench clicks. Follow torque guidelines in the table below. See figures for correct connection points.

Figure 36: LSU090-120HSV5 Piping / Control Box Cover Removal.

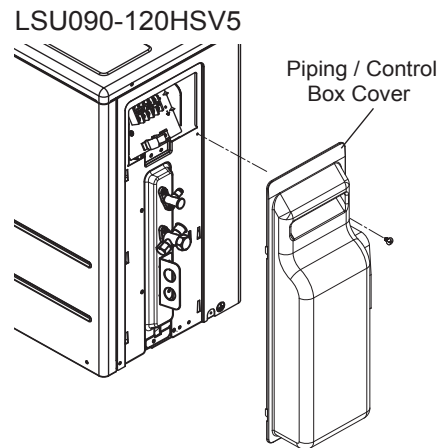

Figure 37: LSU181HSV5 Piping Cover and Control Box Cover Removal.

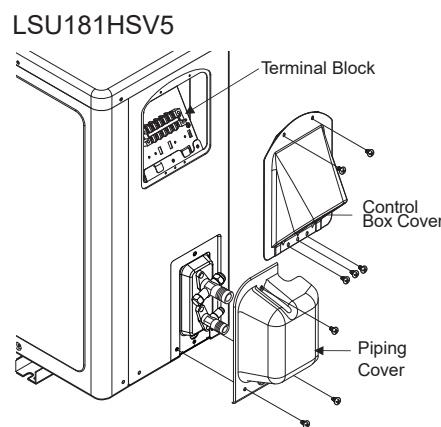

Figure 38: LSU090-120HSV5 Piping Connections.

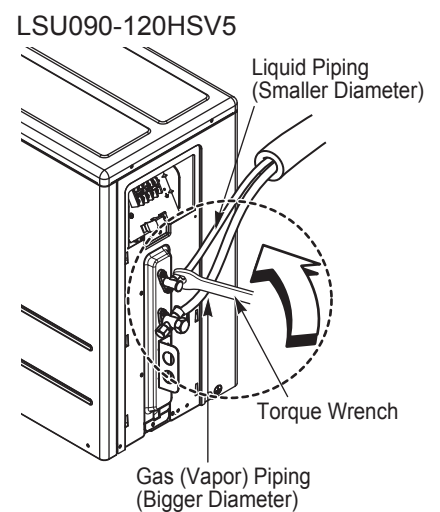

Figure 39: LSU181HSV5 Piping Connections.

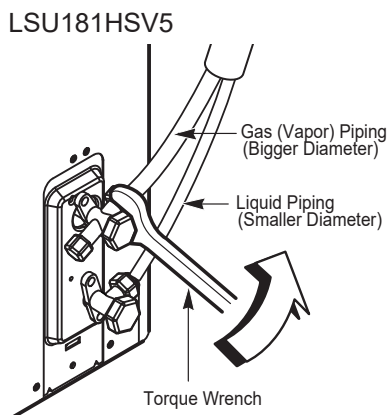

Figure 40: Pipe Attachment.

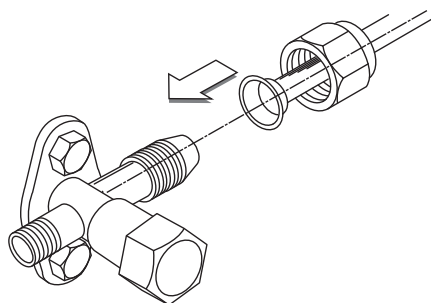

Table 16: Torque Wrench Tightening.

Pipe Size (in. O.D.)	Outside Diameter (mm)	Torque (ft-lbs.)
1/4	6.35	13.0 - 18.0
3/8	9.52	24.6 - 30.4
1/2	12.7	39.8 - 47.7
5/8	15.88	45.4 - 59.3
3/4	19.05	71.5 - 87.5

REFRIGERANT PIPING CONNECTIONS

Indoor Unit Connections

Removing the Indoor Unit Bottom Cover

To access the indoor unit piping port connections, and to make the indoor unit installation procedure easier, it is recommended that the bottom cover be removed first.

1. Unsnap the bottom cover at its top left and right sides (Location 1).
2. Unsnap each of the three (3) or four (4) small C-hooks located in the middle of the bottom cover (Location 2). Number of C-hooks present depends on model of indoor unit.
3. Lift the three (3) to four (4) hinges on the bottom cover up and out of the channels molded to the left, right, and middle of the indoor unit (Location 3). Number of hinges present depends on model of indoor unit.
4. Set aside the bottom cover to re-install after all procedures are complete.

Figure 41: Removing the Bottom Cover.

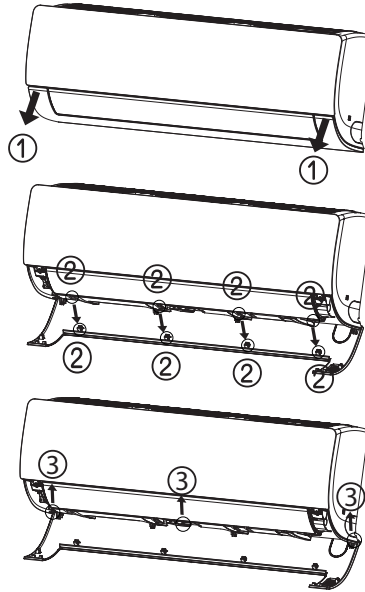
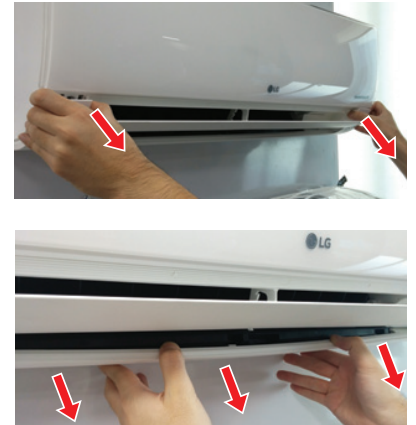

Figure 42: Removing the Bottom Cover, Alternate View.



Accessing and Positioning the Indoor Unit Piping / Connections

1. Unsnap the piping / drain hose holder (L-bracket) out from the indoor unit chassis. Prop it open between the indoor unit chassis and installation plate to separate the bottom of the indoor unit from the wall. This will allow for more working space.

Figure 43: Propping Open the Piping / Drain Hose Holder (L-bracket).

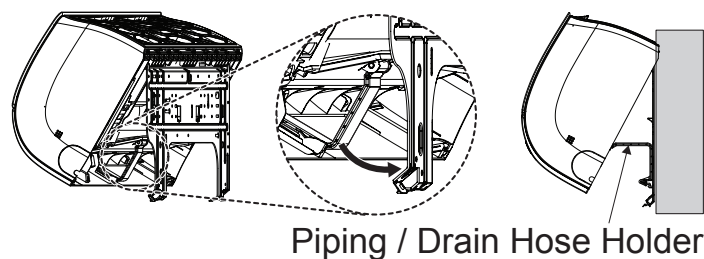
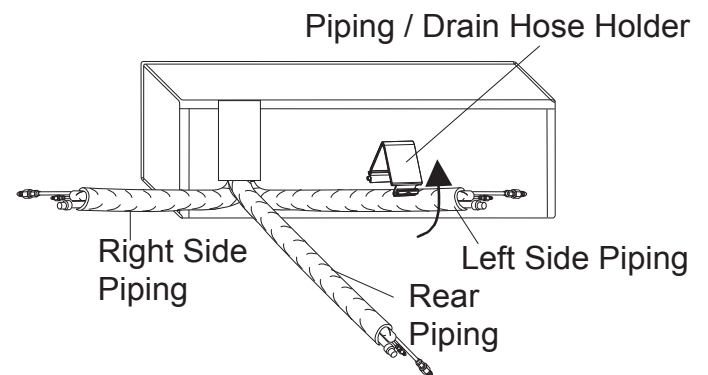

Figure 44: Back of Indoor Unit.



2. Remove the piping port cover.

3. Position the piping by unfolding and bending the piping slowly downward first as shown, then to the left or right (pre-chosen following installation guidelines and application needs) as shown. Secure piping with the piping holder.

Figure 45: Bending Piping at Rear of Indoor Unit.

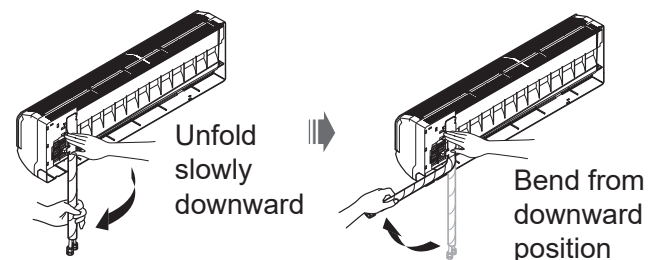

REFRIGERANT PIPING CONNECTIONS

Indoor Unit Connections

Note:

- Do not bend the piping directly backwards or to the left or right sides without bending it downward first; this will damage the indoor unit piping.
- Do not forcibly press the refrigerant piping onto the bottom frame or the front grille; this will damage the indoor unit piping and / or indoor unit frame.
- Ensure the piping is straight. Do not kink the piping; this will damage the indoor unit and piping.

Figure 46: Improper Piping Bending.

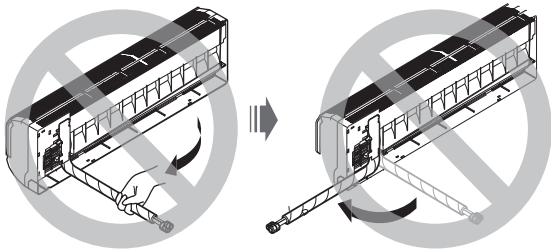

Piping Installation When Piping is on the Left Side

Note:

- See the Electrical System Installation section for information on how to connect the communication / connection (power) cable from the outdoor unit.
- For left-side piping, it is recommended that the communication / power connections are complete before starting the piping connections.

1. Insert drain hose on left (feature will differ depending on model of indoor unit).
2. Align the center of the refrigerant piping and corresponding connection as shown on the next page.
3. Place a couple of drops of refrigerant oil on outside of the flare before assembling. Do not add any contaminants. Tighten the flare nut initially by hand.
4. Finish tightening the flare nut with a torque wrench until the wrench clicks. Follow torque guidelines in the table on the next page.

Note:

When tightening the flare nut with a torque wrench, ensure the direction for tightening follows the arrow on the wrench.

5. Bundle the refrigerant piping, drain hose, and communication / connection (power) cable together. Ensure that the drain hose is located at the bottom of the bundle.
 - If using a conduit for the power wiring / communications cable, see the next page.

Note:

Positioning the drain hose at the top of the bundle can cause condensate to overflow from the drain pan in the inside of the indoor unit.



Figure 47: Keep Piping Straight; Avoid Kinks.

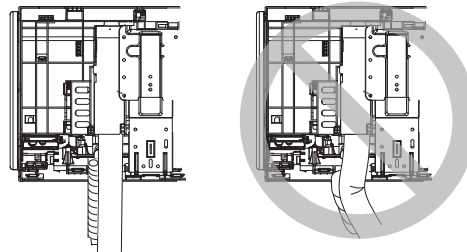
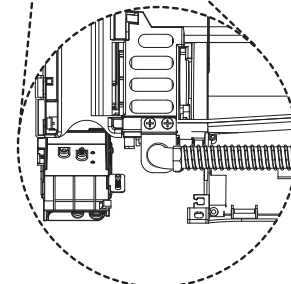
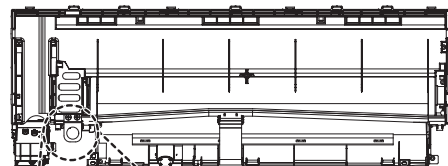
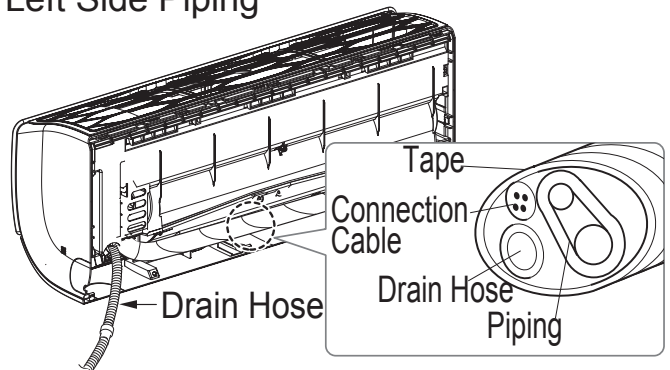

Figure 48: Piping Installation When Piping is on the Left Side.

Left Side Piping



REFRIGERANT PIPING CONNECTIONS

Indoor Unit Connections

Piping Installation When Piping is on the Right Side

Note:

See the *Electrical System Installation* section for information on how to connect the communication / connection (power) wiring from the outdoor unit.

1. Align the center of the refrigerant piping and corresponding connection as shown.
2. Place a couple of drops of refrigerant oil on outside of the flare before assembling. ⚠ Do not add any contaminants. Tighten the flare nut initially by hand.
3. Finish tightening the flare nut with a torque wrench until the wrench clicks. Follow torque guidelines in the table below.

Note:

When tightening the flare nut with a torque wrench, ensure the direction for tightening follows the arrow on the wrench.

4. Bundle the refrigerant piping, drain hose, and communication / connection (power) cable together. Ensure that the drain hose is located at the bottom of the bundle.
 - If using a conduit for the power wiring / communications cable, see below.

Note:

Positioning the drain hose at the top of the bundle can cause condensate to overflow from the drain pan in the inside of the indoor unit.

Table 17: Torque Wrench Tightening.

Pipe Size (in. O.D.)	Outside Diameter (mm)	Torque (ft-lbs.)
1/4	6.35	13.0 - 18.0
3/8	9.52	24.6 - 30.4
1/2	12.7	39.8 - 47.7
5/8	15.88	45.4 - 59.3
3/4	19.05	71.5 - 87.5

Using a Conduit for Indoor Unit Wiring / Cable Installation

Note:

Use a liquidtight 3/4 inch elbow connector for flexible conduit.

1. Prop indoor unit away from wall bracket.
2. Guide communication / connection (power) cable insulation into the conduit.

Note:

- Check local, state, and federal codes when choosing a conduit size.
3. Attach conduit using the liquidtight 3/4 inch elbow connector.
 4. Reassemble the indoor unit properly onto the wall bracket.
 5. If conduit is not used, see pages in this section for refrigerant piping, condensate drain, power wiring / communication cable bundling information.
 6. To protect the piping, condensate drain, and conduit from the elements, add a lineset cover from the indoor access hole to the outdoor unit.

Figure 49: Piping Installation When Piping is on the Right Side.
Right Side Piping

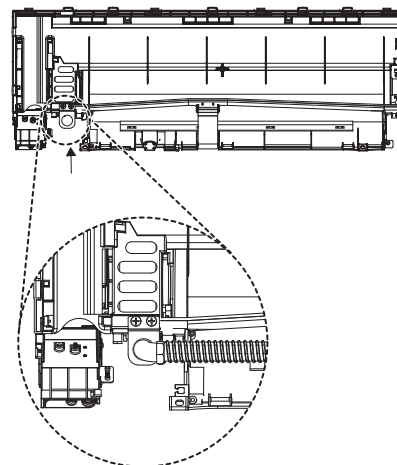
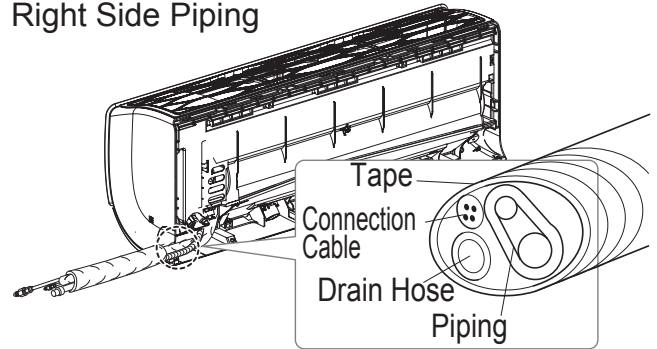

Figure 50: Indoor Unit Connection.

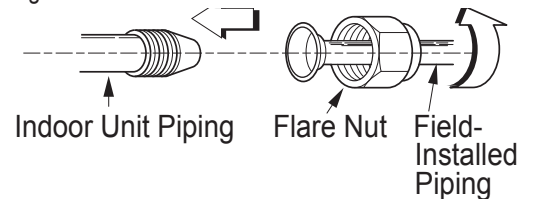
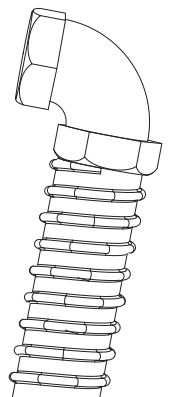

Figure 51: Liquidtight 3/4 Inch Elbow Connector Attached to Flexible Conduit.



REFRIGERANT PIPING CONNECTIONS

Outdoor Unit Drain Piping / Indoor Unit Drain Hose

Outdoor Unit Condensate Drain Piping Installation

Depending on the installation location, it could be necessary to install factory-supplied drain plug(s). See pages 12 to 15 for information in reference to outdoor unit placement.

Note:

Ensure drain piping is insulated. Drain water from the defrost mode will freeze and build up in the outdoor unit, impairing heating performance, and even will damage the outdoor unit.

Installing Outdoor Unit Drain Plug / Piping

1. See diagrams at right for drain connection, drain caps, and drain washer locations specific to each outdoor unit. Components and location differ depending on model of outdoor unit.
2. Connect field-supplied vinyl condensate piping to the outdoor unit drain connection. If the field-supplied vinyl piping is too long, position it to prevent kinks.

Note:

Check local codes for materials approved for field-supplied condensate drain piping.

Indoor Unit Condensate Drain Hose Installation

Note:

Refer to the diagrams below and follow proper installation and the position of the drain hose along the refrigerant piping installation path to avoid leaks. After the drain hose is set in place, always follow with leak / pressure testing and deep evacuation procedures of the refrigerant piping to be sure all refrigerant piping is properly installed. Re-check and retest as necessary.

- Remove the drain plug on left or right side depending on the piping installation.
- Insert the drain hose on the left side when left side piping is used; install the drain hose on the right side when right side piping is used.
- Drain hose is routed from the indoor unit through the structure (wall) to the outdoor. It must slope at an angle where it is higher at the indoor unit and lower toward the outdoor area, thereby letting gravity push any condensation down and out.
- The drain hose might need to be extended so that condensate can be properly routed away.
- The drain hose extension must be properly insulated to ensure condensation will not damage walls, floors, etc. Foamed polyethylene or equivalent of at least 5/16 inches thick is required.

Figure 54: Correct Slope Angle for Drain Hose.

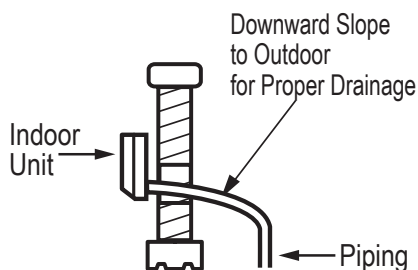

Figure 52: LSU090-120HSV5 Drain Component Locations.

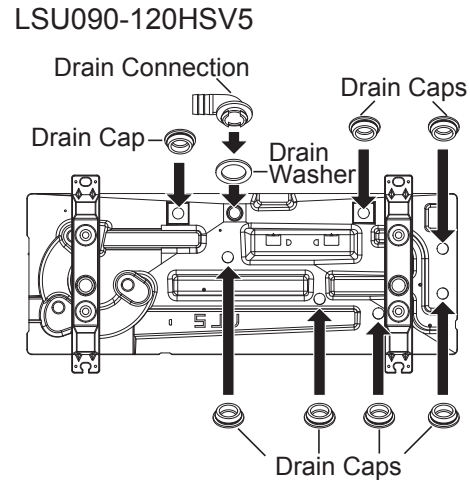

Figure 53: LSU181HSV5 Drain Component Locations.

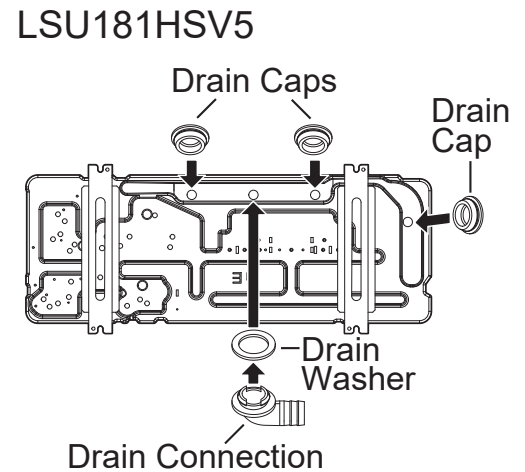
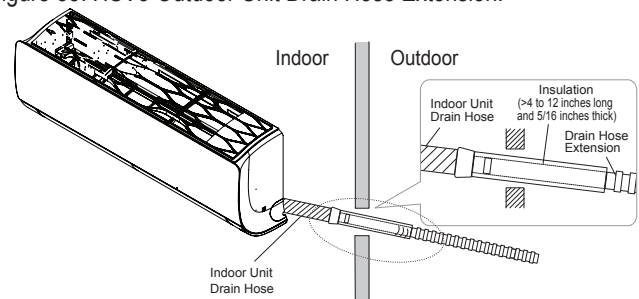

Figure 55: HSV5 Outdoor Unit Drain Hose Extension.



REFRIGERANT PIPING CONNECTIONS

Indoor Unit Drain Hose

- Insert the drain hose >2 inches so it won't pull out of the field-supplied drain pipe.
- ⚠️ Avoid piping the drain hose as shown in the diagrams in the figure below. These methods are incorrect and can cause leaks at the indoor unit site.

Figure 56: Inserting the Drain Hose >2 inches Into the Field-Supplied Drain Pipe.

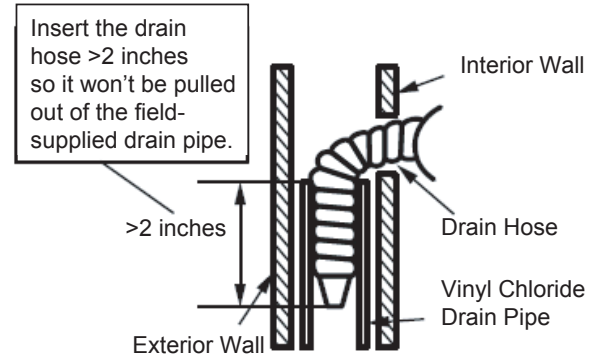
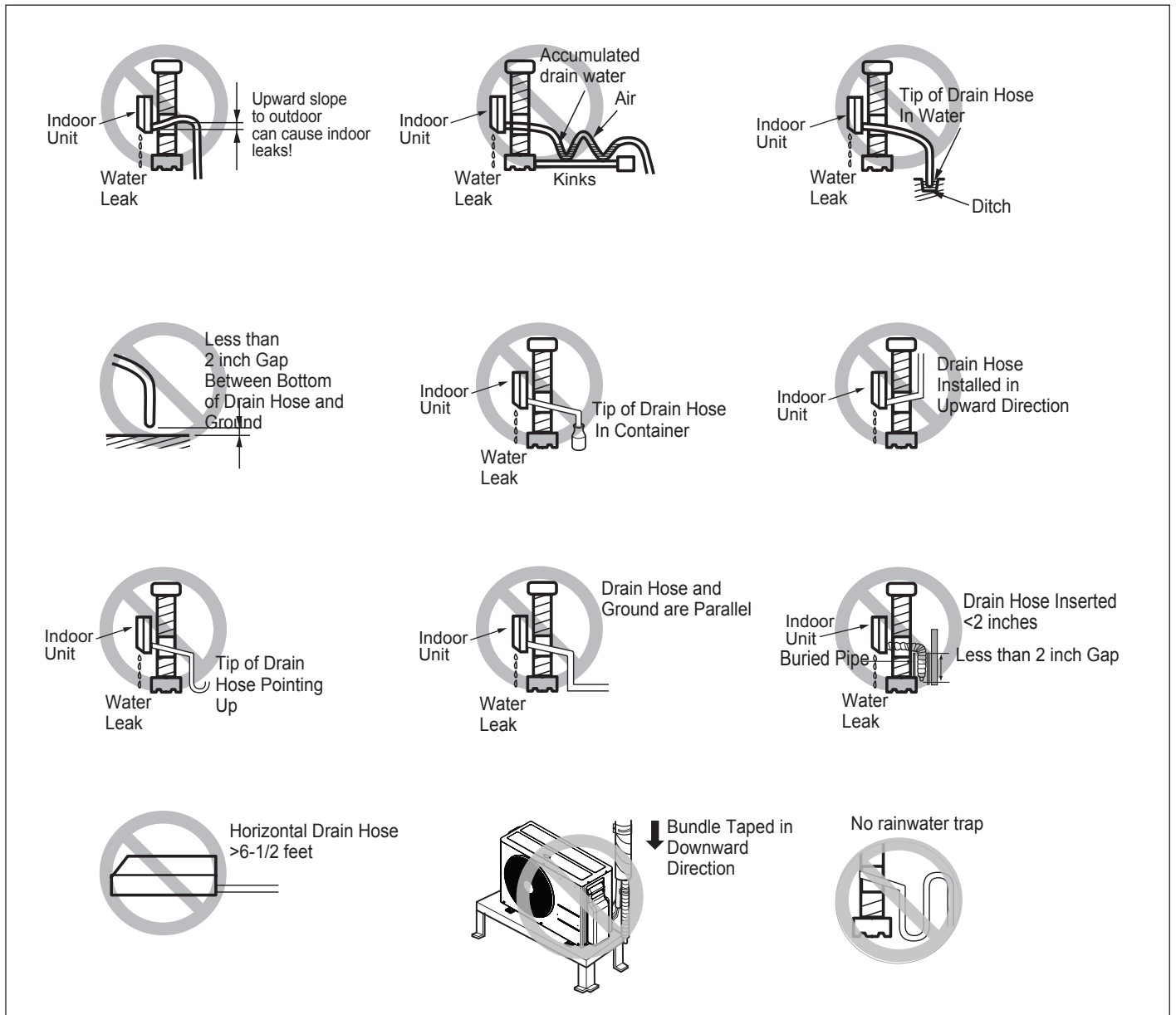

Figure 57: Incorrect Slope Angles for the Drain Hose.



REFRIGERANT PIPING CONNECTIONS

Indoor Unit Drain Hose

Checking the Indoor Unit Drain Hose for Leaks

1. Pour a glass of water on the evaporator.
2. Verify that the water flows appropriately through and out of the drain hose without any leaks.

Figure 58: Checking for Leaks at the Indoor Unit.

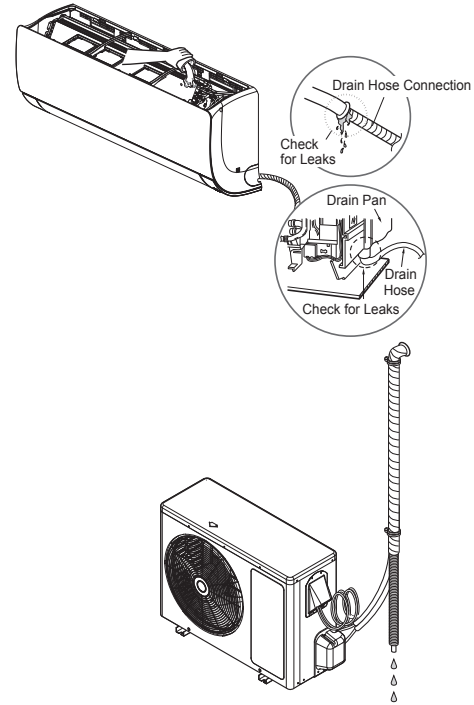

Bundling

If a conduit or piping set cover is not used on the connection from the outdoor unit to the interior, bundle both separately insulated refrigerant pipes, the drain hose, and outdoor unit to indoor unit communication / connection (power) cable together with wide vinyl tape.

1. Both piping must be fully and separately encased in insulation material: Overlap the field installation piping insulation material and the indoor unit piping insulation material.
2. Bind together the two pipes, using vinyl tape. Make sure there are no gaps during the binding.
3. Be sure the cutting line is placed upward.
4. Wrap the rear piping section with narrow vinyl tape.
5. Continue to wrap the indoor unit pipe as connected to the outdoor connection pipe.
6. Using a wider vinyl tape, bundle the piping and drain hose together.
 - Tape must be sufficient to cover the piping in order to fit into the rear piping housing area at the back of the indoor unit.

Note:

- Always include insulation on all refrigerant and drain piping to ensure condensate does not form and cause damage to walls, floors, etc.

Figure 59: Bundling the Connection Components (From Outdoor Unit to Indoor Unit)

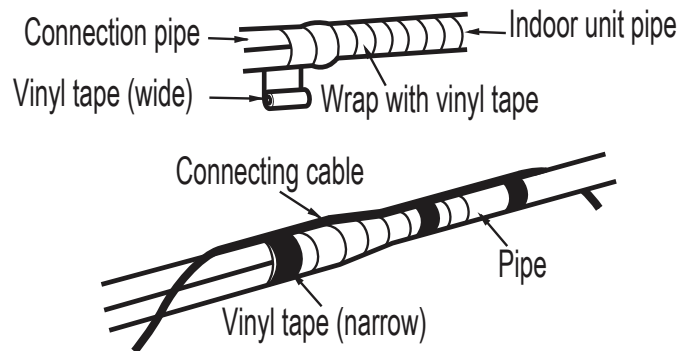
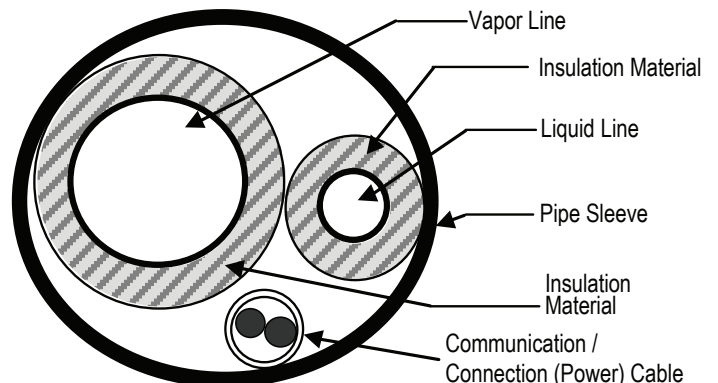

Figure 60: Cutaway of Proper Pipe and Cable Bundling.



INSULATION

Refrigerant Piping System Insulation

Note:

For information regarding insulation for underground or penetration situations, see the “General Refrigerant Piping System Information” section.

All refrigerant piping from the outdoor unit to the indoor units must be insulated correctly for safety and usage. Refrigerant piping, field-provided isolation ball valves (if present), service valves, and elbows must be properly and completely insulated using closed cell pipe insulation (up to the indoor unit piping connections). To prevent heat loss / heat gain through the refrigerant piping, all refrigerant piping including liquid lines and vapor lines must be insulated separately. Insulation must be a minimum 1/2 inches thick, and thickness will need to be increased based on ambient conditions and local codes. Table on next page lists minimum wall thickness requirements for Ethylene Propylene Diene Methylene (EPDM) insulation.

Inside the outdoor unit, maximum pipe temperature is 248°F and minimum pipe temperature is -40°F. For field insulation of refrigerant piping between outdoor units and indoor units, consider the following pipe temperature ranges for an operating heat pump system:

- Heating mode refrigerant temperature ranges: Liquid = 75-118°F; High Pressure Vapor = 95-220°F
- Cooling mode refrigerant temperature ranges: Liquid = 75-118°F; Low Pressure Vapor = 40-90°F

All insulation joints must be glued with no air gaps. Insulation material must fit snugly against the refrigeration pipe with no air space between it and the pipe. ⚠ Do not allow insulation passing through pipe hangers, inside conduit, and/or sleeves to be compressed. Protect insulation inside hangers and supports with a second layer. All pipe insulation exposed to the sun and outdoor elements must be properly protected with PVC, aluminum vapor barrier, or alternatively placed in a weather-resistant enclosure such as a pipe rack with a top cover; and meet local codes.

Figure 61: Typical Pipe Insulation, Power Wire and Communications Cable Arrangement.

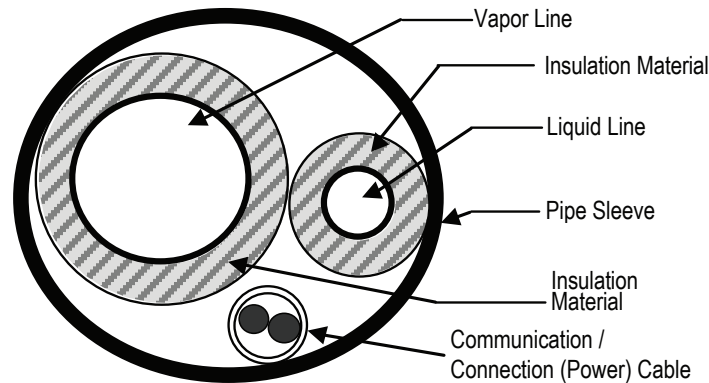

Figure 64: Insulating the Shut Off / Insulation Ball Valve (If Present).

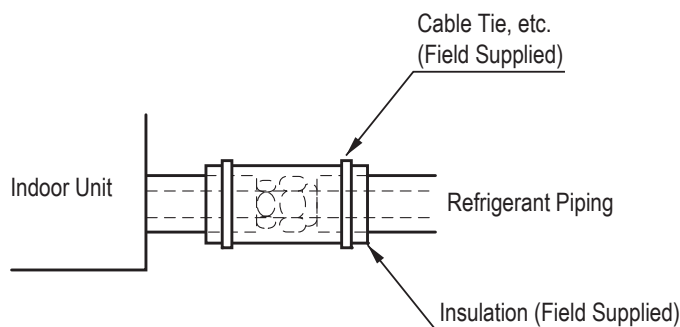

Figure 62: Typical Insulation Butt-Joint at Indoor Unit Casing.

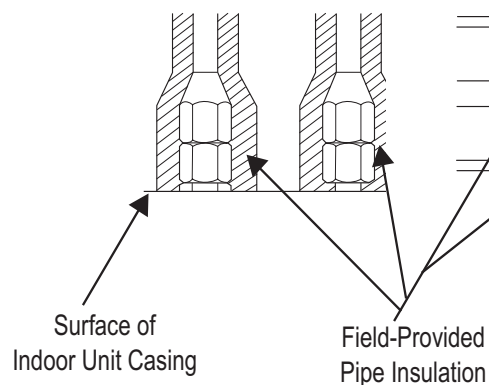
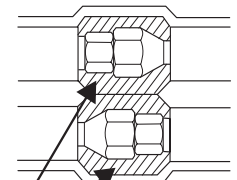

Figure 63: Typical Refrigerant Flare Fitting Insulation Detail.



Note:

Always include plenty of insulation on all refrigerant and drain piping to ensure condensate does not form and cause damage to walls, floors, etc.

Minimum Refrigerant Pipe Ethylene Propylene Diene Methylene (EPDM) Insulation Wall Thickness Requirements

Note:

-  Do not insulate gas and liquid pipes together as this can result in pipe leakage and malfunction due to extreme temperature fluctuations.
- Always properly insulate the piping. Insufficient insulation will result in condensation, reduced heating/cooling performance, etc. Also, if the pipes aren't insulated properly, condensation could potentially cause damage to building finishes. Pay special attention to insulating the pipes installed in the ceiling plenum.
- Fully insulate the piping connections.
- Follow locals codes and the designer's instructions when selecting ethylene propylene diene methylene (EPDM) insulation wall thickness.

Table 18: Minimum Refrigerant Pipe EPDM Insulation Wall Thickness Requirements.¹

Classification / Piping O.D.		Air-conditioned location		Non-air conditioned location	
		1. Typical Conditioned Location	2. Special Conditioned Location	3. Typical Unconditioned Location	4. Special Unconditioned Location
Liquid pipe	ø1/4 inch	>1/2 inches	>1/2 inches	>1/2 inches	>1/2 inches
	ø3/8 inch				
	≥ø1/2 inch				
Vapor pipe	ø3/8 inch	>1/2 inches	>3/4 inches	>3/4 inches	>1 inch
	ø1/2 inch				
	ø5/8 inch				
	ø3/4 inch				
	ø7/8 inch				
	ø1 inch	>3/4 inches	>1 inch	>1 inch	
	ø1-1/8 inches				
	ø1-1/4 inches				
	ø1-3/8 inches				
	ø1-1/2 inches				
ø1-3/4 inches					

¹The thickness of the above insulation material is based on heat conductivity of 0.61 Btu/in/h/ft²/°F.

1. Typical Conditioned Location

A building plenum or space that contains conditioned air that does not exceed 80°F DB.

2. Special Conditioned Location

1. When the location is air conditioned, but there is severe temperature/humidity difference due to high ceilings.
 - Church, auditorium, theater, lobby, etc.
2. When the location is air conditioned, but internal temperature/humidity are high.
 - Bathroom, swimming pool, locker room, etc.

3. Typical Unconditioned Location

An unconditioned space inside a building.

4. Special Unconditioned Location: If conditions 1 and 2 below are present.

1. An unconditioned space or plenum of a building.
2. An area where there is an elevated humidity level.

5. Additional Insulation for Indoor Units May be Required in Humid Environments.

The air conditioner factory insulation has been tested according to "ISO Conditions with Mist," and it satisfies the requirements. If the system has been operating for a long time in a high humidity environment (dew point temperature: more than 73°F), condensate is likely to form. If this happens, install 3/8 inch thick EPDM insulation that is plenum-rated with a heat-resistance factor of more than 248°F.

ELECTRICAL SYSTEM INSTALLATION

Safety Guidelines / Connections and Specifications

⚠ WARNING

- All power wiring and communication cable installation must be performed by trained service providers working in accordance with local, state, and National Electrical Code (NEC) / UL / ETL federal regulations related to electrical equipment and wiring, and following the manufacturer product diagrams, requirements, and instructions in this manual. Failure to do so will lead to electric shock which can cause physical injury or death.
- Verify that main power to the unit is completely off before proceeding. Follow all safety and warning information outlined at the beginning of this manual. Failure to do so will cause electric shock and bodily injury or death.
- Familiarize yourself with the location of the circuit breaker. Be sure that a circuit breaker or some other emergency power cutoff device is in place before any power wiring is done to the system. Failure to do so will cause bodily injury or death.
- ⓧ Never touch any power lines or live cables before all power is cutoff to the system. To do so will cause bodily injury or death.
- Undersized wiring will lead to unacceptable voltage at the unit and will cause a fire, which will cause bodily injury or death.
- Properly ground the Single Zone outdoor and indoor units. Ground wiring is required to prevent accidental electrical shock, bodily injury, and death during current leakage.
- Ground wiring must always be installed by a trained technician.
- Install appropriately sized breakers / fuses / overcurrent protection switches and wiring in accordance with local, state, and NEC regulations related to electrical equipment and wiring, and following the instructions in this manual. Using an oversized breaker or fuse will result in electric shock, physical injury or death.
- ⓧ Do not connect ground wire to refrigerant, gas, or water piping; to lightning rods; to telephone ground wiring; or to the building plumbing system. Failure to properly provide a NEC-approved earth ground can result in electric shock, fire, physical injury or death.

Note:

- Consider ambient conditions (temperature, direct sunlight, inclement weather, etc.) when selecting, installing, and connecting the power wiring.
- Properly ground the Single Zone outdoor and indoor unit. Improperly connected ground wire can cause communication problems from electrical noise and motor current leakage. Ground wiring must always be installed by a trained technician.
- Install appropriately sized breakers / fuses / overcurrent protection switches and wiring in accordance with local, state, and NEC regulations related to electrical equipment and wiring, and following the instructions in this manual. Using an oversized breaker or fuse will result in equipment malfunction and property damage.
- ⓧ Do not connect ground wire to refrigerant, gas, or water piping; to lightning rods; to telephone ground wiring; or to the building plumbing system. Failure to properly provide a NEC-approved earth ground can result in property damage and equipment malfunction.
- ⓧ Do not operate the air conditioning system until the refrigerant piping installation is complete. Operating the system before refrigerant piping is finalized will damage the compressor.

Power Wiring / Communication Cable Connections

Best practice dictates using solderless ring or fork terminals at all power wiring and communication cable terminations. Use copper bearing ring or fork terminals; ⓧ do not use galvanized or nickel plate over steel. Use appropriate crimping tool to attach the ring or fork terminals at all power wiring and control cable terminations.

To Install a Ring or Fork Terminal:

1. Trim the wiring with wire cutters or pliers, then strip the insulation to expose the strand wiring to about 3/8 inches.
2. Using a ring terminal fastener or pliers, securely clamp a ring terminal to each stripped wire end.

Figure 65: Close up of a Typical Ring Terminal.

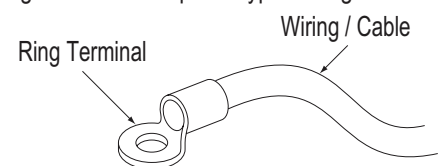
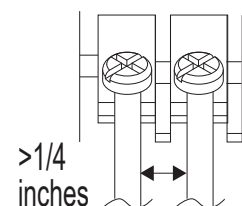

Figure 66: Distance Between the Terminal Connections.



ELECTRICAL SYSTEM INSTALLATION

Connections and Specifications

Power Wiring / Communication Cable Connections, continued

To Connect the Wiring to the Terminals:

1. Remove the JIS terminal screws from the (outdoor unit or indoor unit) terminal plate with a JIS screwdriver. (See information about LG terminal connections below.)
2. Position the ring terminal around the terminal, place the terminal screw in the ring, and tighten to the terminal plate using a JIS screwdriver.
 - Firmly attach the wire; secure in a way to prevent external forces from being imparted to the terminal block.
 - Use an appropriately sized JIS screwdriver for tightening the terminals.
 - ⚠ Do not overtighten the connections; overtightening will damage the terminals.

If ring terminals or fork terminals are not available, then:

- ⚠ Do not terminate different gauge wires to the power terminal block. (Slack in the wiring will generate heat.)
- When terminating wires of the same thickness, follow the instructions demonstrated in the figures below.

⚠ WARNING

If power wires are not properly terminated and firmly attached, there is risk of fire, electric shock, and physical injury or death.

Note:

- ⚠ Never apply line voltage power to the communications cable terminal block. If contact is made, the PCBs will be damaged.
- Always include some allowance in the wiring length when terminating. Firmly attach the wiring or cable, but provide some slack to facilitate removing the electrical panels while servicing, and to prevent external forces from damaging the terminal block.

Figure 69: Proper and Improper Power Wiring Connections.

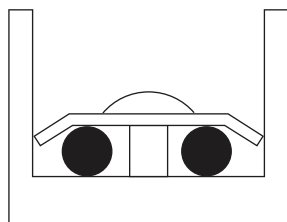

Terminate multiple power wires of the same gauge to both sides.

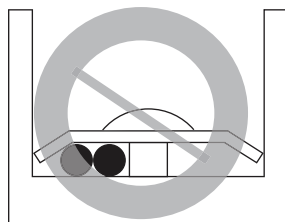

⚠ Do not terminate two wires of one side.

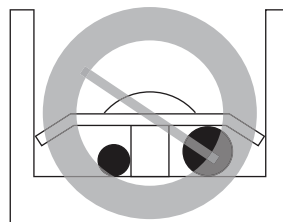

⚠ Do not terminate different gauge wires to a terminal block.

Terminal Connections

LG uses a “JIS” type of screw for all terminals; use a JIS screwdriver to tighten and loosen these screws and ⚠ avoid damaging the terminal. ⚠ Do not overtighten the connections — overtightening will damage the terminals — but firmly and securely attach the wiring in a way to prevent external forces from being imparted to the terminal block.

Note:

- The terminals labeled “GND” are NOT ground terminals. The terminals labeled ⚡ ARE ground terminals.
- Polarity matters. Always connect “A” to “A” and “B” to “B.”
- ⚠ Do not include splices or wire nuts in the communication cable.

Figure 67: Adding a Ring Terminal to the Wiring.

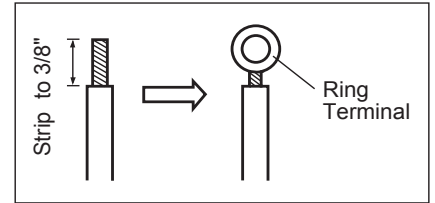
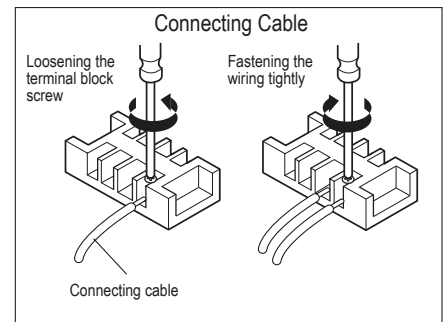
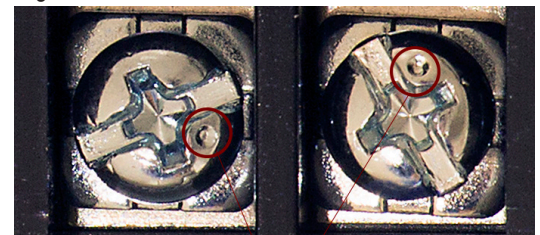

Figure 68: Tightening the Ring Terminal to the Terminal Plate.



● :Copper Wire

Figure 70: JIS Screws.



JIS DIMPLES

ELECTRICAL SYSTEM INSTALLATION

Connections and Specifications

Power Supply / Power Wiring Specifications

- LG Single Zone systems operate at 1Ø, 208-230V, 60Hz.
- Power wiring / power wiring gauge to the outdoor unit(s) must be solid or stranded, and must comply with all National Electrical Code (NEC), UL, and local electrical codes.
- The indoor unit is powered by the outdoor unit.
- Power supply, wire types and sizes, and circuit breaker must be selected based on NEC, UL, and local codes. Maximum allowable voltage fluctuation $\pm 10\%$ or nameplate rated value.
- Properly ground the outdoor unit and indoor unit per NEC, UL, and local codes.
- Ground wire must be longer than the common power / communication wires.
- Connect the wiring firmly so the wires cannot be easily pulled out.
- Refer to the inside of the chassis cover or control cover for circuit and terminal block diagrams.
- Always match color codes of each wire and follow wiring diagram.
- ⓧ Do not install power wiring to the outdoor unit and the communication / connection (power) cable to the indoor unit in the same conduit. Use separate conduits.

Figure 71: Single Zone Outdoor Unit Power Wiring Diagram.

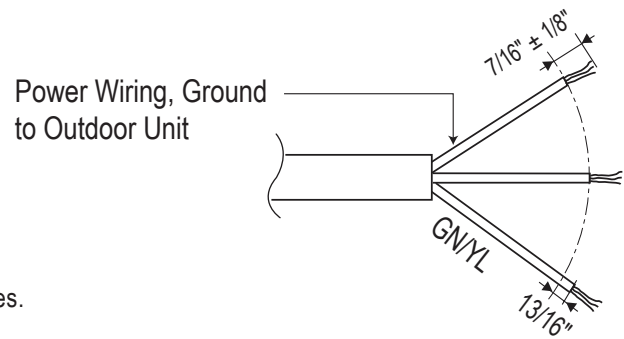

Figure 72: Power Wiring Conduit.



⚠ DANGER

Refer to Electrical Data table for ampere ratings. Properly size all circuit breakers / fuses, wiring and field provided components per local codes. There is risk of fire, electric shock, explosion, physical injury or death.

⚠ WARNING

- All power wiring installation must be performed by trained service providers working in accordance with local, state, and NEC regulations related to electrical equipment and wiring, and following the instructions in this manual. Failure to do so will lead to electric shock and bodily injury or death.
- Use specified wiring for connections, and ensure that external force is not imparted to terminal connections. It will generate heat and / or cause a fire, resulting in physical injury or death.
- Use heat-proof electrical wire capable of withstanding temperatures up to 167°F to avoid wiring malfunction and electrical shock, which will cause physical injury or death.
- Install appropriately sized breakers / fuses / overcurrent protection switches and wiring in accordance with local, state, and NEC regulation related to electrical equipment and wiring, and following the instructions in this manual. Generated overcurrent will include some amount of direct current. Using an oversized breaker or fuse will result in electric shock, physical injury or death.
- Use the appropriate type of overcurrent protection. Generated overcurrent will include some amount of direct current, and if the appropriate type of overcurrent protection is not installed, there is a risk of fire, electric shock, and physical injury or death.
- Ground wiring is required to prevent accidental electrical shock during current leakage, communication problems from electrical noise, and motor current leakage. ⓧ Do not connect the ground line to the pipes. There is risk of fire, electric shock, explosion, physical injury or death.
- Per code, install a main indoor breaker, and an outdoor service disconnect that interrupts all power sources simultaneously. There is risk of fire, electric shock, explosion, physical injury or death.

Note:

- If there is a possibility of momentary blackout, or the power goes on and off while the system is operating, install a field-supplied phase loss protection circuit. If not, the compressor and other components will be damaged.
- Use heat-proof electrical wire capable of withstanding temperatures up to 167°F to avoid damage to unit.
- Install appropriately sized breakers / fuses / overcurrent protection switches and wiring in accordance with local, state, and NEC regulations related to electrical equipment and wiring, and following the instructions in this manual. Generated overcurrent will include some amount of direct current. Using an oversized breaker or fuse will result in equipment malfunction and property damage.
- ⓧ Do not connect ground wire to refrigerant, gas, or water piping; to lightning rods; to telephone ground wiring; or to the building plumbing system. Failure to properly provide a NEC approved earth ground can result in property damage and equipment malfunction.

ELECTRICAL SYSTEM INSTALLATION

Connections and Specifications

Communication / Connection (Power) Cable Specifications from Outdoor Unit to Indoor Unit

- For communication / connection (power) wires between the Single Zone outdoor unit and the indoor unit, use a minimum 14 gauge, four (4) conductor, stranded, shielded or unshielded wire. If shielded, the wire must be grounded to the chassis at the outdoor unit only.
- Insulation material as required by local code.
- Firmly attach the cable; provide slack but secure in a way to prevent external forces from being imparted on the terminal block.
- Wiring must be completed without splices.

Figure 73: Typical Single Zone Outdoor Unit to Indoor Unit Wiring and Communications Cable Diagram.

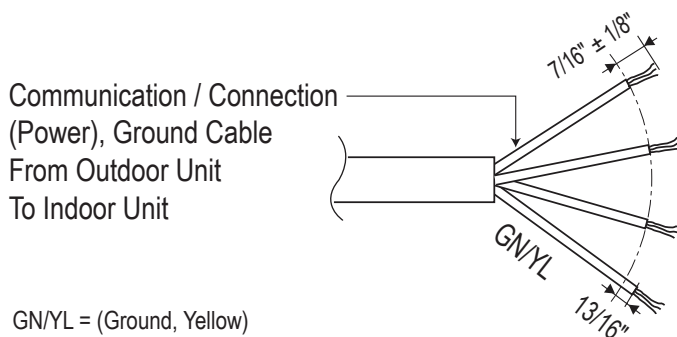

⚠ WARNING

All power wiring and communication cable installation must be performed by trained service providers working in accordance with local, state, and National Electrical Code (NEC) / UL / ETL federal regulations related to electrical equipment and wiring, and following the manufacturer product diagrams, requirements, and instructions in this manual. Failure to do so will lead to electric shock which can cause physical injury or death.

Note:

- Always verify the communication cable is connected to a communications terminal on the Single Zone unit. ⓧ Never apply line voltage power to the communication cable connection. If contact is made, the PCBs will be damaged.
- The shield of the communications cable connecting the outdoor unit to the indoor unit must be grounded only to the outdoor unit frame.
- Tie the shield of each cable segment together using a wire nut at the indoor unit. Maintain polarity throughout the communication network.
- Position the incoming power to the outdoor unit away from the power / communications cables from the outdoor unit to the indoor unit.
- ⓧ Never use a common multiple-core communications cable.

Figure 74: Typical LS090-120HSV5 Power / Communication System Diagram.

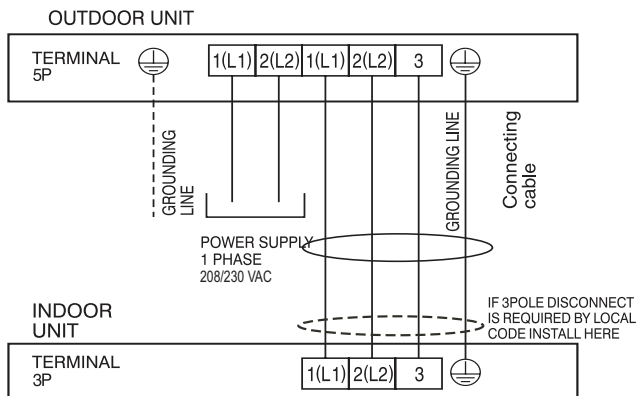
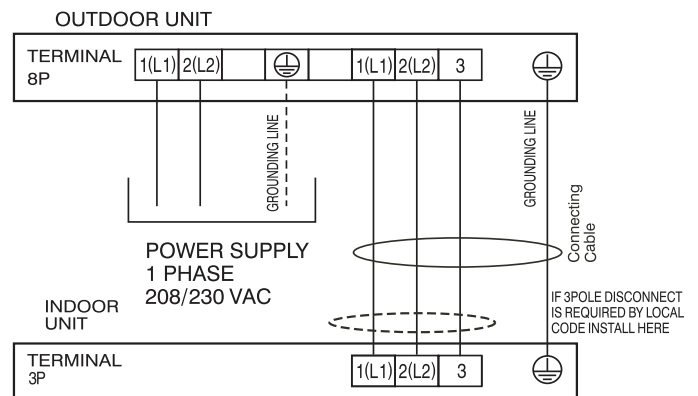

Figure 75: Typical LS181HSV5 Power / Communication System Diagram.



Note:

- Use of 14 gauge, four (4) conductor, stranded, shielded or unshielded wire is allowed for lengths up to the published maximum pipe length, plus recommended slack at both ends.

ELECTRICAL SYSTEM INSTALLATION

Controller Options

Controller Options

Single Zone High Efficiency Standard Wall Mount systems include a wireless handheld remote controller (Model No. AKB74955602), but optional LG-supplied wired controllers are available. See “Functions, Controls, Options” in the Engineering Manual, or contact an LG representative for more information.

Wireless Handheld Remote Controller features:

- Display Panel: Displays operation conditions.
- On / Off Button: Turns system operation on and off.
- Mode Button: Selects the operation mode: Cooling, Heating, Auto, Dry (Dehumidification), or Fan.
- Temp Up / Down Buttons: Adjusts the desired room temperature in the different modes.
- Fan Speed Button: Sets desired fan speed.
- Reset: Initializes the handheld remote control settings.

Figure 76: Example of a Wireless Handheld Remote Controller. Buttons will differ depending on model type.

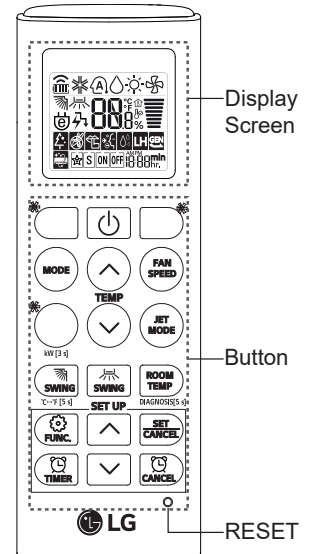

Wired Controller Connections

Optional controllers (see the Single Zone High Efficiency Standard Wall Mount Engineering Manual, or contact an LG representative for more information) can connect to the Single Zone High Efficiency Standard Wall Mount indoor unit in one of two different ways.

1. LG Wired Remote Extension Cable with Molex plug (PZCWRC1; sold separately) that connects to the CN-REMO terminal on the indoor unit PCB.
2. Field-supplied controller cable that connects to the indoor unit terminal block (must be at least UL2547 or UL1007, and at least FT-6 rated if local electric and building codes require plenum cable usage). Communication cable from indoor unit to remote controller(s) is to be 22 AWG, 3-conductor, twisted, stranded, unshielded. Wiring must comply with all applicable local and national codes.

Figure 77: PZCWRC1 LG Wired Remote Extension Cable.

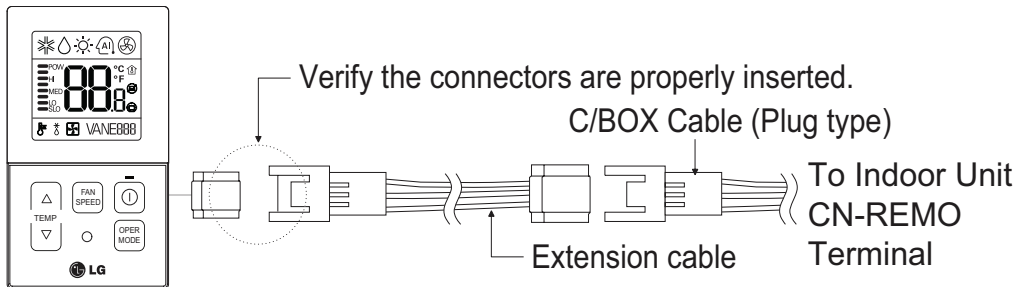

Note:

When using field-supplied controller cable, make sure to connect the yellow to yellow (communications wire), red to red (12V power wire), and black to black (ground wire) terminals from the remote controller to the indoor unit terminal blocks.

Dry Contact

A Dry Contact can also be connected to the High Efficiency indoor unit using the CN-CC connection on the indoor unit PCB. The Dry Contact DC is shipped with a specific connector that is used to connect to the indoor unit.

Central Controller

Additionally, Single Zone High Efficiency systems can be connected to a central controller if a PI-485 VNet Accessory is installed in the outdoor unit. See the Central Controller manual for wiring specifications.

Figure 78: Wired Controller Connections on the Indoor Unit Terminal Block.

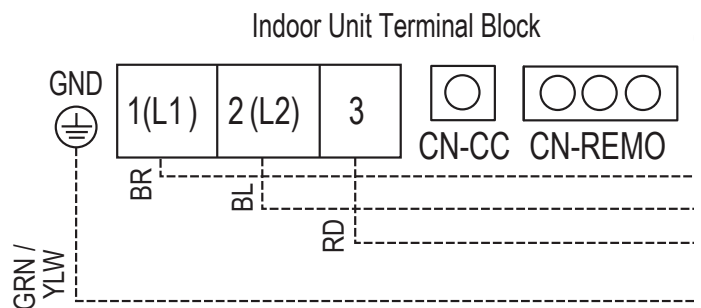

ELECTRICAL SYSTEM INSTALLATION

Indoor Unit Electrical Connections

Connecting Indoor Unit Electrical Wiring

⚠ WARNING

- Verify that main power to the unit is completely off before proceeding with these steps as there is a risk of electrical shock, bodily injury, and / or death.
- Follow all safety and warning information outlined at the beginning and throughout this manual. Failure to do so will cause electrical shock, bodily injury, and / or death.

Note:

- Follow all safety and warning information outlined at the beginning and throughout this manual. Failure to do so will cause unit failure.
- Connect the communication / connection (power) cable to the indoor unit by matching the terminals on the outdoor unit control board. Verify the color of the wires at the outdoor unit, along with the terminal numbers, match those for the indoor unit.
- Images are representative; actual appearance will vary.
- Refer to the circuit diagram on the indoor unit bottom cover.

1. The bottom panel must have already been removed. If it hasn't been removed, unsnap the bottom cover at its top left and right sides (Location 1).
2. Unsnap each of the three (3) or four (4) small C-hooks located in the middle of the bottom cover (Location 2). Number of C-hooks present depends on model of indoor unit.
3. Lift the three (3) to four (4) hinges on the bottom cover up and out of the channels molded to the left, right, and middle of the indoor unit (Location 3). Number of hinges present depends on model of indoor unit.
4. Set aside the bottom cover to re-install after all procedures are complete.
5. Terminal block is located at the front bottom-right—hand side of the indoor unit. To access the terminals, unscrew the metal control cover screw (if applicable), and raise the metal control cover.
6. Using a JIS screwdriver, connect the cable terminals to the terminal block. Ensure wire color and terminal number of the indoor unit matches those of the outdoor unit. Refer to the wiring diagram on the inside of the bottom cover.

Note:

- Each wire must be securely attached to the terminal block.
- Ground cable must be longer than the other wires.
- Secure the cable onto the control board using a cable tie.
- Use a conduit to protect the cable / refrigerant piping from the indoor unit to the outdoor unit.

Figure 79: Steps to Removing the Bottom Cover.

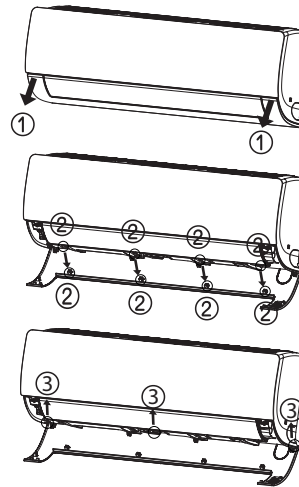

Figure 80: Removing the Bottom Cover (Appearances Will Vary Depending on Indoor Unit Model).

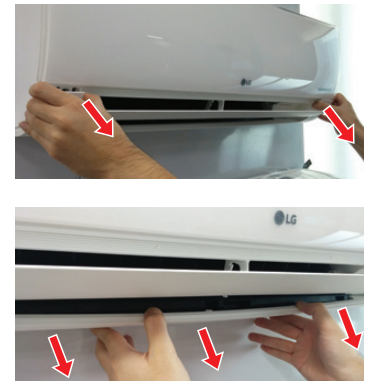

Figure 81: Location of the Indoor Unit Terminal Block.

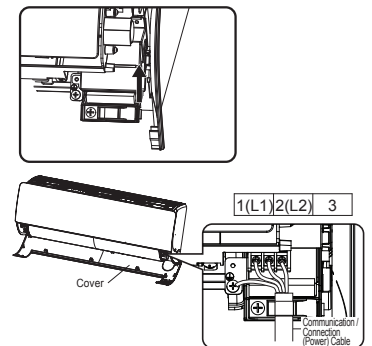

Figure 82: Terminal Cover Down.

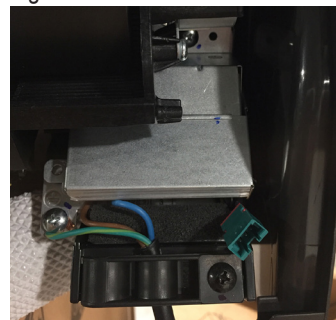
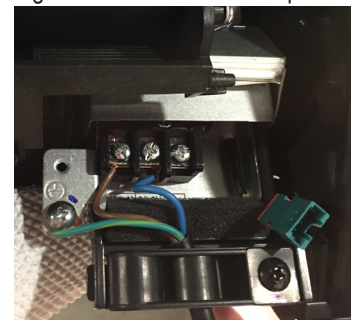

Figure 83: Terminal Cover Up.



ELECTRICAL SYSTEM INSTALLATION

Indoor Unit Electrical Connections

Connecting Indoor Unit Electrical Wiring, continued.

7. Choice of the cable path out of the indoor unit and to the outdoor unit depends on refrigerant piping / drain hose installation: left side piping, following back of indoor unit; right side piping, through the knockout hole; or rear piping.

Cable Installation When Piping is on the Left Side:

- Insert the communication / connection (power) cable through the bottom of the indoor unit,
- Connect the terminals to the terminal block.
- Secure the cable onto the terminal block with the cable retainer.
- Secure the refrigerant piping, drain hose, and communication / connection (power) cable together using cable ties and conduit, or by the bundling method.

Note:

Position the drain hose at the bottom. Positioning the drain hose at the top of the bundle can cause condensate to overflow from the drain pan in the inside of the indoor unit.

Cable Installation When Piping is on the Right Side:

- Connect the terminals to the terminal block.
- Secure the cable onto the terminal block with the cable retainer.
- Secure the refrigerant piping, drain hose, and communication / connection (power) cable together using cable ties and conduit, or by the bundling method.

Note:

Position the drain hose at the bottom. Positioning the drain hose at the top of the bundle can cause condensate to overflow from the drain pan in the inside of the indoor unit.

Note:

For more information on conduits or the bundling method, see the Refrigerant Piping Connection section.

8. Reattach the metal control cover using the screw (if applicable).

Figure 84: Cable / Refrigerant Piping / Drain Hose Installation Options.

Wiring When Piping is on the Left Side

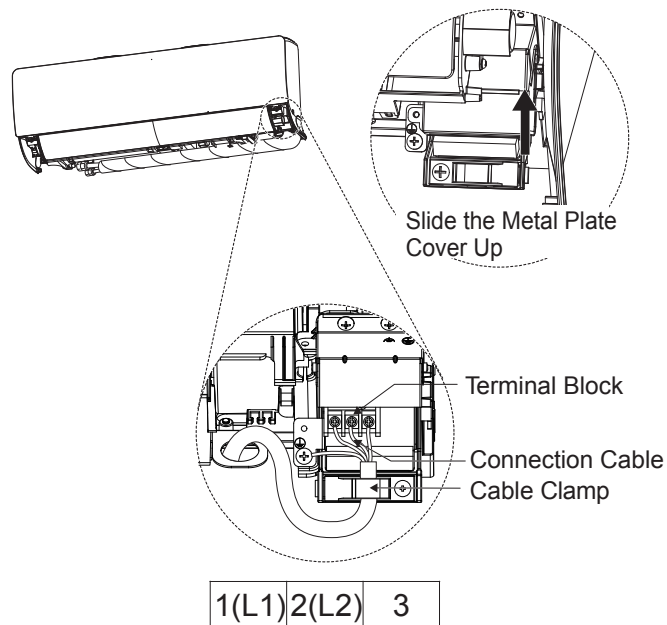

Wiring When Piping is on the Right Side

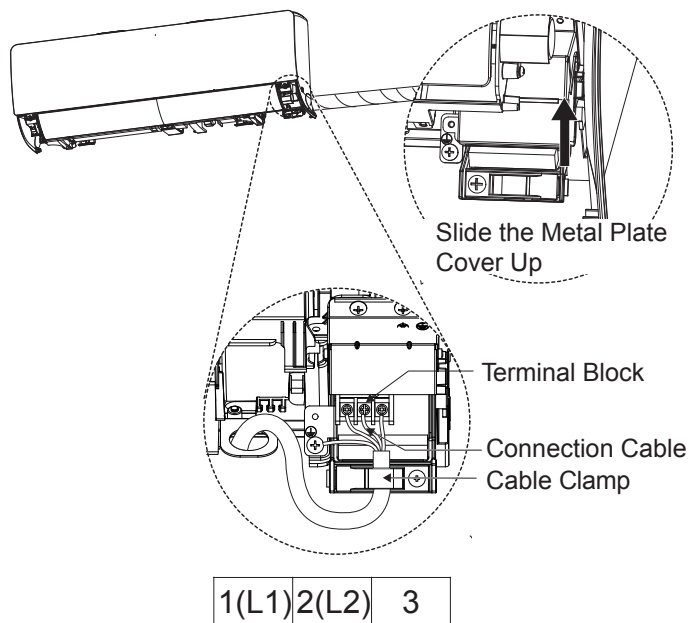

ELECTRICAL SYSTEM INSTALLATION

Outdoor Unit Electrical Connections

Connecting Outdoor Unit Wiring

⚠ WARNING

- Verify that main power is completely off and that no power is going through the Single Zone system before proceeding with these steps. Follow all safety and warning information outlined at the beginning of this manual. Failure to do so will cause electric shock, bodily injury and / or death.
- Per code, install a main indoor breaker, and an outdoor service disconnect that interrupts all power sources simultaneously. There is risk of fire, electric shock, explosion, physical injury or death.
- Verify that the circuit breaker or some other emergency power cutoff device is in place before any power wiring is done to the system. Failure to do so will cause electric shock, bodily injury and / or death.
- ⚡ Never touch any power lines or live cables before all power is cutoff to the system. To do so will cause bodily injury or death.

1. Using a Phillips head screwdriver, remove the piping / control box cover or control box cover (depends on model) from the outdoor unit.
2. Inspect all wiring inside the chassis to be sure they are secure and have not loosen during transportation and installation of the outdoor unit. Inspect wires for damage or cracks.

⚠ WARNING

Loose, damaged, or cracked wires will cause electric shock, bodily injury and / or death.

Note:

Loose wires can cause the wiring to burn out, damaging the outdoor unit.

3. Confirm that electrical power supply capacity will be sufficient to run the unit. Verify that a circuit breaker and service disconnect are installed. See the Electrical table in the Product Data section for details on electrical requirements.

⚠ WARNING

Per code, install a main indoor breaker, and an outdoor service disconnect that interrupts all power sources simultaneously. There is risk of fire, electric shock, explosion, physical injury or death.

4. Confirm that the right gauge size is used for all wiring. Follow all federal, state, and local codes related to wiring.
5. Guide the power wiring to the outdoor unit, and communications / connection (power) cable from the outdoor unit to the indoor unit, through the conduit holes on the outdoor unit or control box cover (see images below and on the next page). Install conduits to protect the wiring and cable.

Figure 85: Circuit Breaker.

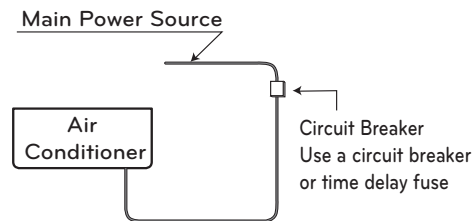

Figure 86: Accessing LSU090-120HSV5 Outdoor Unit Wiring Connections.

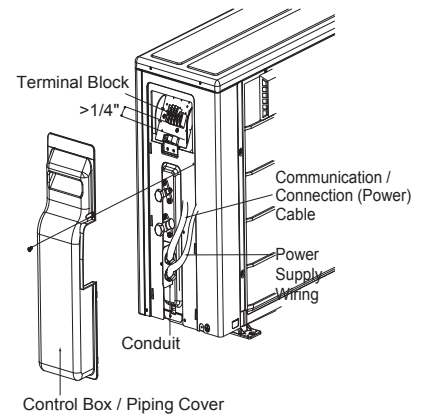
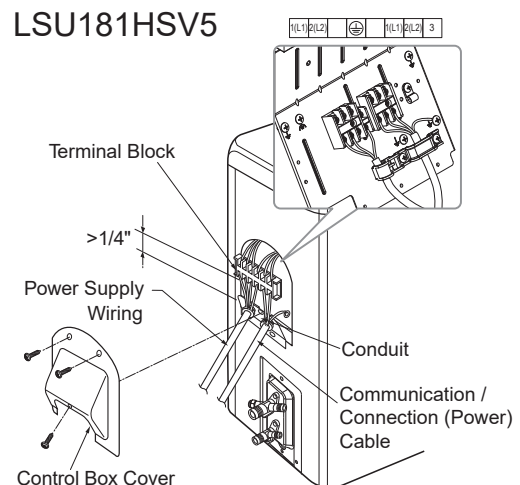

Figure 87: Accessing LSU181HSV5 Outdoor Unit Wiring Connections.



ELECTRICAL SYSTEM INSTALLATION

Outdoor Unit Electrical Connections

Connecting Outdoor Unit Wiring, continued.

Note:

⊘ Do not install power wiring to the outdoor unit and the communication / connection (power) cable to the indoor unit in the same conduit. Use separate conduits. Communication problems will occur.

Figure 88: Example of Conduit.



Figure 89: HSV5 Outdoor Unit Conduit Holes.

LSU090-120HSV5

LSU181HSV5

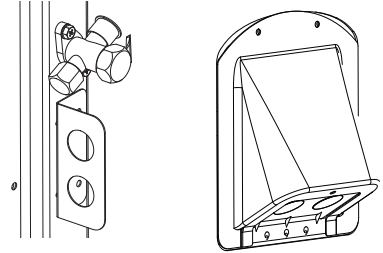

- Using a JIS screwdriver, connect wires as shown at right. See also indoor unit wiring diagram found on its bottom cover, and outdoor unit wiring diagram on the inside of its chassis cover.
 - Each wire must be individually and securely attached to each terminal.

⚠ WARNING

Loose, damaged, or cracked wires will cause electric shock, bodily injury and / or death.

Note:

Loose wires can cause the wiring to burn out, damaging the outdoor unit.

- Secure wiring / cables with cable ties.
- Pay attention to the location / connection of the ground cable.
- Maintain a minimum of 1/4 inches of wire length from terminal block to cable bundle.

- When finished, reattach the piping / control box cover or control box cover (depends on model) to the outdoor unit with the screws.

Figure 90: Outdoor Unit Electrical Connections.

LSU090-120HSV5 Outdoor Unit Terminal Block

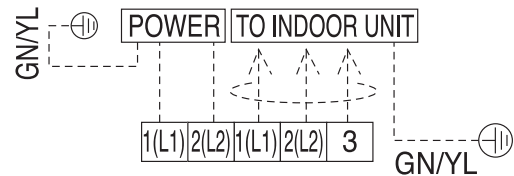

LSU181HSV5 Outdoor Unit Terminal Block

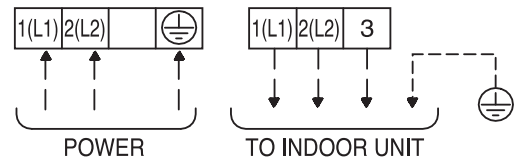

FINAL INSTALLATION PROCEDURES

Triple Leak / Pressure Test

Triple Leak / Pressure Test

After the refrigerant piping installation is complete, perform a triple leak / pressure test. Triple leak / pressure test is performed between the outdoor unit and indoor unit to verify that refrigerant can flow through the system without danger of leaks or pressure losses. Air and moisture that is left in the piping can lead to undesirable results and can cause damage to the system. It is important to go through a complete leak / pressure cycle to be sure that the refrigerant piping is cleared out. This process will have to be repeated if any air or moisture be is found to remain in the piping.

Note:

Insufficient or incorrectly done air purging will lead to the following:

- Pressure in the system can rise.
- Operating current can rise.
- Inefficient cooling or heating mode capability.
- Moisture in the refrigerant circuit will freeze and block capillary tubing.
- Water can lead to corrosion of parts in the system.

⚠ DANGER

Using combustible gases, including oxygen will result in fire or explosion, resulting in personal injury or death. Use inert gas (medical-grade dry nitrogen) when checking leaks, cleaning, installing/repairing pipes, etc. The use of a 600 psig nitrogen regulator is required for safety.

Note:

- ⚠ Never perform the leak test using refrigerant.
- ⚠ To avoid nitrogen entering the refrigerant system in a liquid state, the top of the cylinder must be higher than its bottom (used in a vertical standing position) when the system is pressurized.
- Use only a leak-free gauge manifold set.
- Piping system must not be pressured to more than 550 psi. Pressures greater than 550 psi will damage the piping system and cause unit malfunction.

Triple Leak / Pressure Check Procedure

1. After the refrigerant piping installation is complete, open the isolation ball valves, if any, that will have been included in the piping system.
2. Verify that both the liquid and gas (vapor) suction line outdoor unit service ports are closed, and the stem head access caps are tight. The leak / pressure check is to be performed only to the refrigerant piping system and the connected indoor unit.
3. Remove the cap on the gas (vapor) suction line Schrader port. Connect the (medical-grade dry) nitrogen cylinder regulator to a gauge manifold, then connect the gauge manifold to the gas (vapor) suction Schrader port on the service port.
4. Perform the leak / pressure check at 150 psig for fifteen (15) minutes (standing pressure check).
5. Perform the leak / pressure check at 300 psig for thirty (30) minutes (standing pressure check).
6. Perform the leak / pressure check at 550 psig for one (1) hour to make sure the piping system is leak-free. After the gauge reading reaches 550 psig, isolate the system by first closing the gauge manifold, then close the nitrogen cylinder valve. Check the flared (and any brazed connections) for leaks by applying a bubble solution to all joints.

Note:

The bubble solution must be a solution designed for refrigerant leak testing. Common soap solution must ⚠ never be used on refrigerant piping as those contain chemicals that could corrode copper and brass, and cause product malfunction.

Figure 91: Outdoor Unit Service Valves.

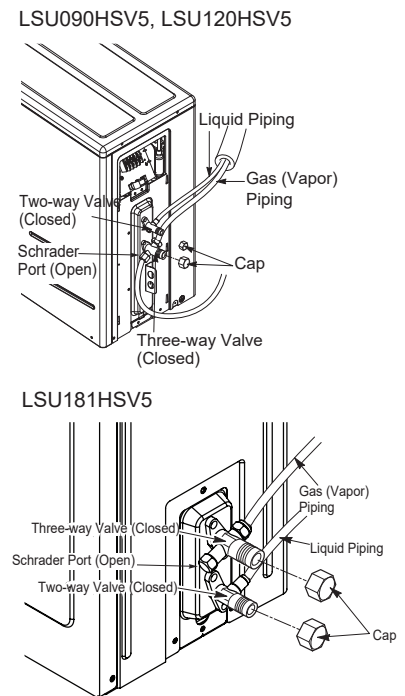
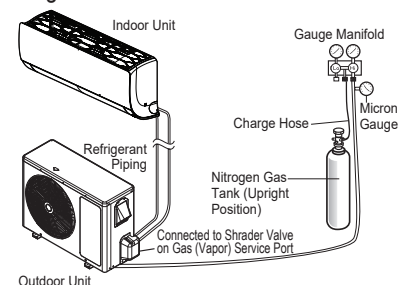

Figure 92: Triple Leak / Pressure Test Diagram.



FINAL INSTALLATION PROCEDURES

Triple Leak / Pressure and Deep Evacuation Tests

Triple Leak / Pressure Check Procedure, continued.

7. If the pressure does NOT drop for one (1) hour, the system passes the test.
8. If the pressure drops, there is a leak and it must be found. Remove the bubble solution with a clean cloth, repair the leak(s), and perform the leak / pressure check again.
9. After the system has been thoroughly tested and no leaks are found, depressurize by loosening the charging hose connector at the nitrogen cylinder regulator. When system pressure returns to normal, completely disconnect the charging hose from the cylinder, and release the nitrogen charge from all refrigerant piping. Wipe off any remaining bubble solution with a clean cloth.

Deep Evacuation Procedure

After the leak / pressure check is complete, it is required that a deep evacuation procedure is performed to the refrigerant piping and the connected indoor unit. Deep evacuation must be performed through the gas (vapor) suction line Schrader port on the outdoor unit service port.

Note:

The deep evacuation procedure is required for Single Zone systems. A triple evacuation procedure seen on the previous page is a best practices recommendation for Single Zone systems.

Note:

For faster evacuation, the Schrader core can be removed, and an auxiliary service port can be used. Make sure to re-install the original Schrader core before operating the system.

- Deep evacuate through just the gas (vapor) suction Schrader port on the outdoor unit service port.
- The outdoor unit service valves must remain closed and the stem head access caps tight. ⚠ Do not open the outdoor unit service valves and release the factory refrigerant charge until trim charge is complete, and the system is ready to operate.
- Any field-installed ball valves in the refrigerant system (if used) must be open to ensure all piping is free and clear for deep evacuation on all piping and the connected indoor unit.

Note:

- ⚠ Do not apply power to the system before performing the deep evacuation procedure. There is a possibility that the EEV valve may close and isolate sections of the piping system, making the deep evacuation procedure inconclusive.
- ⚠ Never perform evacuation using refrigerant.
- Use only a vacuum pump that can reach 500 microns, vacuum rated hoses or copper tubing, and a leak-free gauge manifold set.
- Use only new vacuum pump oil from a properly sealed (unopened) container, and change oil in pump before EVERY use.
- Subsequent oil changes will be necessary after several hours of continuous operation; have extra oil on hand.
- Use a quality micron gauge in good operating order and install as far away from pump as possible.

Deep Evacuation Procedure Steps

1. If this procedure is performed shortly after the leak / pressure test, the cap and core on the gas (vapor) suction Schrader port must have already been removed, and the manifold must already be connected. If the procedure was not performed shortly after the leak / pressure test, make sure to remove the cap and core on the gas (vapor) suction Schrader port. Verify that the service valves on the outdoor unit are closed, and the stem head access caps are tight.
2. Connect the gauge manifold along with the vacuum pump to the gas (vapor) suction Schrader port (with core removed) using a vacuum hose. Open the gauge manifold and the vacuum pump valves.

FINAL INSTALLATION PROCEDURES

Deep Evacuation and Triple Evacuation Tests

Deep Evacuation Procedure, continued.

3. Evacuate to static micron level ≤ 500 for at least one (1) hour.
4. Micron level must remain ≤ 500 for two (2) hours. If the vacuum gauge rises and stops, the system may contain moisture; therefore, it will be necessary to repeat the steps of vacuum break and drying.
5. After maintaining the system in vacuum for two (2) hours, check if the vacuum gauge rises or not. If it doesn't rise, then the system is properly evacuated.
6. Close manifold gauges.
7. Shut the valves before turning off and disconnecting the vacuum pump.

Triple Evacuation Procedure

After the leak / pressure check is complete, it is a best practices recommendation that a triple evacuation procedure is performed to the refrigerant piping and the connected indoor unit. Triple evacuation must be performed through the gas (vapor) suction Schrader port on the outdoor unit service port.

Note:

The deep evacuation procedure is required for Single Zone systems. The triple evacuation procedure is a best practices recommendation for Single Zone systems.

Note:

For faster evacuation, the Schrader core can be removed, and an auxiliary service port can be used. Make sure to re-install the original Schrader core before operating the system.

- Evacuate through just the gas (vapor) suction Schrader port on the outdoor unit service port.
- The outdoor unit service valves must remain closed and the stem head access caps tight. ⚠ Do not open the outdoor unit service valves and release the factory refrigerant charge until trim charge is complete, and the system is ready to operate.
- Any field-installed ball valves in the refrigerant system (if used) must be open to ensure all piping is free and clear for evacuation on all piping and connected indoor unit.

Note:

- ⚠ Never perform evacuation using refrigerant.
- Use only a vacuum pump that can reach 500 microns, vacuum rated hoses or copper tubing, and a leak-free gauge manifold set.
- Use only new vacuum pump oil from a properly sealed (unopened) container, and change oil in pump before EVERY use.
- Subsequent oil changes will be necessary after several hours of continuous operation; have extra oil on hand.
- Use a quality micron gauge in good operating order and install as far away from pump as possible.

Figure 93: Evacuation Procedure Diagram.

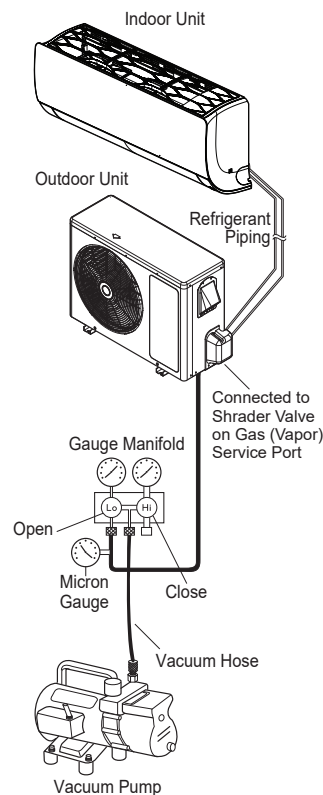

FINAL INSTALLATION PROCEDURES

Triple Evacuation Test

Triple Evacuation Procedure Steps

1. If this procedure is performed shortly after the leak / pressure test, the cap and core on the gas (vapor) suction Schrader port must have already been removed, and the manifold must already be connected. If the procedure was not performed shortly after the leak / pressure test, make sure to remove the cap and core on the gas (vapor) suction Schrader port. Verify that the service valves on the outdoor unit are closed, and the stem head access caps are tight.
2. Connect the gauge manifold along with the vacuum pump to the gas (vapor) suction Schrader port (with core removed) using a vacuum hose. Open the gauge manifold and the vacuum pump valves.

Note:

After the vacuum pump is first operated, if hoses, manifold, and vacuum valves are leak free (and oil is not moisture laden), the gauge must read <100 microns within one (1) minute.

⊘ *Do not proceed if the gauge does not read <100 microns within one (1) minute. There is a leak in the hose, gauge manifold, or vacuum valve, and the equipment must be replaced.*

3. Operate the vacuum pump and evacuate the system to the 2,000 micron level. Isolate the pump by closing the manifold gauges and the vacuum pump valve, and then watch the micron level. Micron level will rise a bit, but MUST eventually stop rising for fifteen (15) minutes.
 - If the micron level DOES NOT stop rising, there is a leak, and the leak test must be performed again.
 - If the micron level DOES rise above 2,000 micron, re-open the manifold gauges and the vacuum pump valve and continue evacuation back down to 2,000 micron level.
 - If the micron level holds at 2,000 micron, continue to step 4.
4. Break vacuum with 50 psig nitrogen purge for an appropriate amount of time (this is to “sweep” moisture from piping).
5. Purge nitrogen from the system until the pressure drops down to 1 to 3 psig.
6. Evacuate to 1,000 micron level. Isolate the pump by closing the manifold gauges and the vacuum pump valve, and then watch the micron level. Micron level will rise a bit, but MUST eventually stop rising for fifteen (15) minutes.
 - If the micron level DOES NOT stop rising, there is a leak, and the leak test must be performed again.
 - If the micron level DOES rise above 1,000 micron, re-open the manifold gauges and the vacuum pump valve, and continue evacuation back down to 1,000 micron level.
 - If the micron level holds at 1,000 micron, continue to step 7.
7. Break vacuum with 50 psig nitrogen purge for an appropriate amount of time.
8. Purge nitrogen from the system until the pressure drops down to 1 to 3 psig.
9. Evacuate to static micron level ≤ 500 for at least one (1) hour.
10. Micron level must remain ≤ 500 for two (2) hours. If the vacuum gauge rises and stops, the system may contain moisture; therefore, it will be necessary to repeat the steps of vacuum break and drying.
11. After maintaining the system in vacuum for two (2) hours, check if the vacuum gauge rises or not. If it doesn't rise, then the system is properly evacuated.
12. Close manifold gauges.
13. Shut the valves before turning off and disconnecting the vacuum pump.

FINAL INSTALLATION PROCEDURES

Refrigerant Trim Charge, Finishing the Job

Refrigerant Trim Charge

The single zone system will need an additional refrigerant charge if the installed piping lengths are greater than the “piping length (no additional refrigerant, ft.) specification” listed in the product tables. See the product sections in the engineering and installation manuals. The additional refrigerant charge can be calculated manually using the information in the engineering and / or installation manuals, or by LATS.

1. Keep the outdoor unit service valves closed while adding the trim charge to the system. See the specification tables in the front of this installation manual for base charge, and see below for the correct additional refrigerant trim charge amounts for each system.
2. Charge through just the gas (vapor) suction Schrader port.

⚠ WARNING

- Follow all guidelines when handling refrigerant.
-  Never inhale or handle refrigerant directly. Doing so will cause bodily injury.

Table 19: Single Zone High Efficiency Refrigerant Piping System Additional Refrigerant Charge.

Model Numbers		Refrigerant Piping Length (ft.)											
		16.4	24.6	32.8	41.0	49.2	65.6	82.0	98.4	114.8	131.2	147.6	164.0
LS090HSV5 (LSN090HSV5 / LSU090HSV5)	Additional Refrigerant Charge (oz.)	0	0	0	0	1.8	5.4	9.0	-	-	-	-	-
LS120HSV5 (LSN120HSV5 / LSU120HSV5)		0	0	0	0	1.8	5.4	9.0	-	-	-	-	-
LS181HSV5 (LSN181HSV5 / LSU181HSV5)		0	0	3.1	6.2	9.3	15.6	21.8	28.0	34.3	-	-	-

Note:

- Capacity is based on standard length.
- Equivalent Pipe Length = Actual Pipe Length + Number of Bends x 0.3.
- Additional Refrigerant Charge Calculation : $X (g) = [(Refrigerant\ Pipe\ Length) - (No\ Charge\ Pipe\ Length)] \times (Additional\ Refrigerant)$.
- There is no need to add refrigerant if equivalent pipe is less than the “piping length with no additional refrigerant” in the table above.

Finishing the Job

After the Triple Leak and Evacuation (and refrigerant trim charge, if any) procedures have been performed, follow the steps below to open the refrigerant lines.

1. Verify that the auxiliary service port is removed (if used in the Evacuation procedure) and the original Schrader core was re-installed on the gas (vapor) suction service port.
2. The service ports are a back-seated type with a right hand thread. Remove the service valve caps on both the gas (vapor) suction and the liquid service ports.
3. Using an appropriately sized Allen wrench, fully open the valves on both the gas (vapor) suction and the liquid service ports by turning the valve stem counterclockwise.
4. Turn until the valve stem is out, stops, and the valve is completely backseated.  Do not apply excessive force.
5. Securely replace service port caps on both the gas (vapor) suction and the liquid using an adjustable wrench.

FINAL INSTALLATION PROCEDURES

Reattaching the Indoor Unit Bottom Cover

Reattaching the Indoor Unit Bottom Cover

Reattach the indoor unit bottom cover after all other installation procedures are complete.

1. If ON, shut power OFF to the system.
2. At the bottom of the bottom cover, insert the three (3) to four (4) hinges into the channels molded to the left, right, and middle of the indoor unit (Location 1). Number of hinges present depends on model of indoor unit.
3. After all hinges are secure, match the three (3) or four (4) small C-hooks located in the middle of the bottom cover (Location 2) to their sockets on the indoor unit. (Number of C-hooks present depends on model of indoor unit.) On the outside of the bottom cover, securely snap the C-hooks in place at each location using the heel of the palm.
4. Match the snaps at the top left and right sides of the bottom cover to their sockets, and push to lock the bottom cover to the indoor unit (Location 3).
5. Verify the bottom cover is securely installed by pushing the bottom cover to the indoor unit at all attachment locations.

Note:

To prevent bending the bottom cover (and subsequent damage), assemble the bottom cover correctly.

Figure 94: Close Up of Bottom Cover Connections (Appearances Will Vary Depending on Indoor Unit Model).

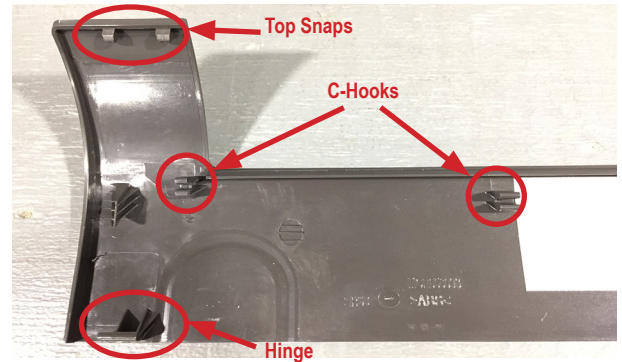

Figure 95: Inserting the Bottom Cover Hinges into the Indoor Unit Channels (Step 2).

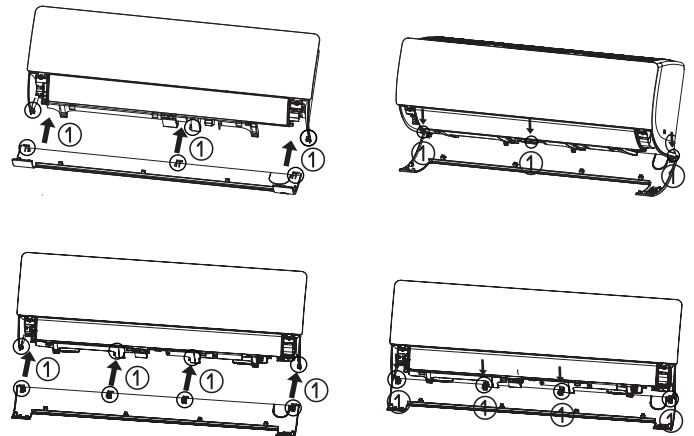

Figure 96: Securing the Bottom Cover C-hooks to the Indoor Unit Sockets (Step 3).

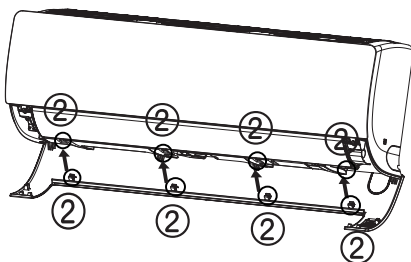

Figure 97: Snapping the Top Left and Right Sides (Step 4).

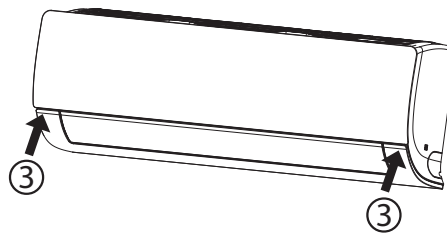
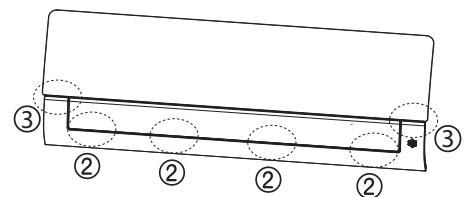

Figure 98: Checking that All Attachment Locations Are Secure (Step 5).



FINAL INSTALLATION PROCEDURES

Air Filter Disassembly and Assembly

Air Filter Disassembly and Assembly

Air Filter Disassembly

1. Turn power off to the system.
2. Find the handles located at the top-front of the air filter molded into the plastic frame support.
3. Lift handles slightly up and out to remove the air filter.

Figure 99: Disassembling the Air Filter (Appearances Will Vary Depending on Indoor Unit Model).

2. Lifting the Air Filter by the Handles.



3. Disassembling the Air Filter.



Air Filter Assembly

1. Turn power OFF to the system.
2. Holding the air filter by its handles, match the hooks and grooves on the air filter to the hooks and grooves at the top-back of the indoor unit. (Number of hooks and grooves present depends on model of indoor unit.)
3. Match the air filter bars and grooves to the grooves and hooks at the top-front of the indoor unit.
4. Use thumbs to gently snap the air filter to the indoor unit where the top-front bars, grooves, and hooks are located.
5. Check the sides of the front grille to verify the air filter is assembled correctly.
6. Turn power back on to the system.

Figure 100: Assembling the Air Filter (Appearances Will Vary Depending on Indoor Unit Model).

2. Matching Hooks to Top-Back Grooves.



- Three (3) Top-Back Hooks to Grooves.



- Four (4) Top-Back Hooks to Grooves.

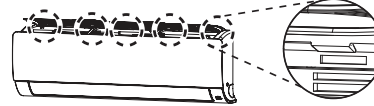

3. Location of Two (2) Top-Front Bars.

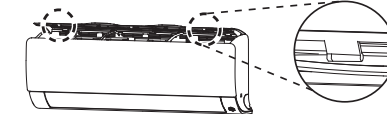

- Example of Indoor Unit Hook to Air Filter Groove.

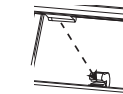

4. Securing the Air Filter on the Indoor Unit.



5. Checking the Sides for Correct Air Filter Assembly.



Note:

- It is easier to assemble and disassemble the air filter if standing on a ladder looking down at the top of the indoor unit.
- ⚠ Do not bend the air filter; this damages it.
- If the air filter is not assembled correctly, dust and other substances will enter the indoor unit.

FINAL INSTALLATION PROCEDURES

Installing Batteries, Test Run, Performance Evaluation

Installing Batteries into the Handheld Remote Controller

For information on using the handheld remote controller, refer to its owner's manual.

1. The remote controller needs two AAA (1.5V) batteries for operation. Remove the battery cover from the back of the remote controller by pushing the tab down in the direction seen at right.
2. Insert the two new batteries.
 - Align batteries by the (+) and (-) sides.
 - The interior battery compartment of the remote controller will have clear markings for the (+) and (-) placement.
3. Verify that the batteries have clicked into the compartment and are firmly engaged with the contacts on either side of them.
4. Reattach the back cover of the remote controller.
5. Proceed with powering on the remote controller and use as needed. Remove the batteries if system won't be used for an extended time.

Figure 101: Installing the Remote Controller Batteries.

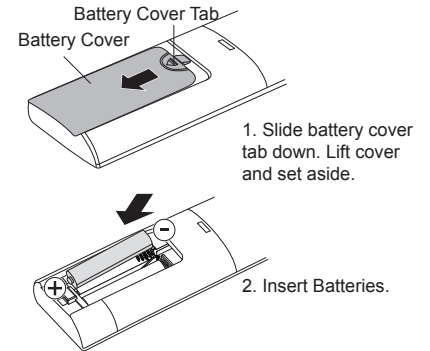

Test Run

After all installation procedures are complete, the system is ready for a test run. Follow the guidelines below.

1. Check that all drain piping, refrigerant piping, and wiring / cables are properly connected.
2. Check that both the gas (vapor) suction and liquid refrigerant piping service valves are fully open.
3. Install the batteries into the handheld remote controller (see above).
4. Turn on the power to the outdoor unit, and press and hold the On / Off button for three (3) to five (5) seconds; this switches the system to test operation mode.
5. The system will operate in cooling with maximum air flow for 18 minutes before returning to the factory default setting. While system operates in the test operation mode, note any issues that occur, and fix as necessary.

Figure 102: Test Operation Mode.

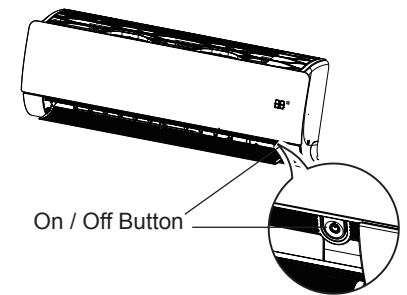

Performance Evaluation

Operate the unit in heating and / or cooling, depending on outdoor conditions, for 15 to 20 minutes, then check the system refrigerant charge (feature availability depends on model):

1. Measure the pressure of the gas (vapor) suction service valve. See optimum psig in table at right.
2. Measure the air temperature from both the inlets and outlets.
3. Verify the difference between the inlet and outlet temperatures is > 14.4°F.
4. The air conditioner is now ready to use.

Figure 103: Performance Evaluation Measurement Locations.

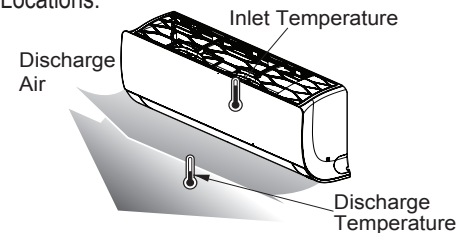

Table 20: Gas Side Pressure at Optimum Condition When System is in Cooling.

Outside Ambient Temperature	Gas (Vapor) Service Valve Pressure
95°F	120~135 psig

Note:

- If all modes can't be tested all at one time, testing must be performed later when weather conditions permit.
- If the actual pressure is higher than shown, the system is most likely overcharged, and charge must be removed. If the actual pressure is lower than shown, the system is most likely undercharged, and charge must be added.

FINAL INSTALLATION PROCEDURES

Installer Mode, Heating Only Mode

Installer Mode

It will be necessary to switch to Installer mode if the system needs to operate in Heating Only or Cooling Only modes, or the Pump Down procedure needs to be performed.

To Enter Installer Mode:

1. Press the Reset and “A” buttons. A very slender tool is needed to access the Reset button.
2. Set the code by pressing the Up and Down Temperature buttons, and then press the ON / OFF button. The Up Temperature button changes the code on the ten (10) digit; the Down Temperature button changes the code on the one (1) digit.

Figure 104: Using the Handheld Controller to Change System to Installer Mode.

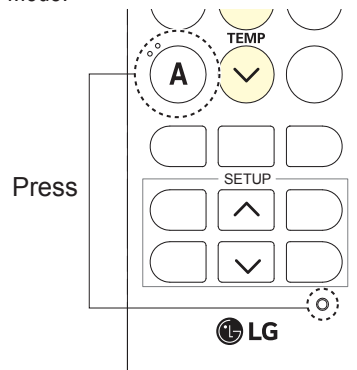

Enabling Heating Only Mode

To be able to run Heating Only mode, the unit must be changed to Installer mode (see above for instructions).

1. Supply power to the system, but system must be OFF with all functions inactive.
2. Enter the Installer mode.
3. Set code to 47.
4. Press the ON / OFF button and select the code number 47. Unit will beep to acknowledge that the code has been received.
5. Turn off power for a minimum of 30 seconds.
6. Turn power back on to system.

Disabling Heating Only Mode

1. Supply power to the system, but system must be OFF with all functions inactive.
2. Enter the Installer mode.
3. Set code to 48.
4. Press the ON / OFF button and select the code number 48. Unit will beep to acknowledge that the code has been received.
5. Turn off power for a minimum of 30 seconds.
6. Turn power back on to system.

Note:

- After the Heating Only mode is set, Cooling, Dehumidification, Auto Changeover modes cannot be used.
- After Heating Only mode is disabled, system operation will return to normal.
- Codes cannot be entered when the system is operating. The system must be OFF to enter the codes. Even if the code is entered when the system is ON, the function won't operate.
- During Heating Only Mode, if the system is turned OFF when the handheld controller is used to set the system to operate in modes other than Heating or Fan, the system will not turn back ON. Turn the system OFF after the handheld controller is used to system the system to Heating or Fan, and then turn back ON.

FINAL INSTALLATION PROCEDURES

Cooling Only Mode, Pump Down Procedure

Enabling Cooling Only Mode

Before running the Pump Down procedure, the unit must be switched to Cooling Only mode. To be able to run Cooling Only mode, the unit must be changed to Installer mode (see previous page for instructions).

1. Supply power to the system, but system must be OFF with all functions inactive.
2. Enter the Installer mode.
3. Set code to 45.
4. Press ON / OFF button and select the code number 45. Unit will beep to acknowledge that code has been received.
5. Turn off power for a minimum of 30 seconds.
6. Turn power back on to system.

Note:

- After the system is in Installer mode (with Cooling Only mode initiated), automatic operation is suspended.
- After Cooling Only mode is disabled, the system will return to normal operation.
- Installer mode cannot be entered if the unit is running. The system must be completely OFF.
- All Installer code numbers must be entered when system is OFF.
- WLAN Module's communication time will lag by about one (1) minute after unit is turned back on, and in normal operating mode.
- Entire lock or Mode lock cannot be set if heating or automatic operation is set through a central controller.

Pump Down Procedure

This procedure is performed when the refrigerant piping system is serviced. Pumping down collects all the refrigerant in the outdoor unit without losing any charge. Always adhere to and be familiar with local codes regarding the handling of refrigerant.

The system must operate in Cooling Only mode to proceed with the pump down procedure. If needed, refer to the previous sections for proper steps to place the unit into Cooling Only mode.

1. Turn off the unit's power switch. Connect a low-pressure gauge manifold hose to the charge port on the gas (vapor) suction service valve.
2. Open the gas (vapor) suction service valve halfway, and purge the air in the manifold hose using the refrigerant.
3. Fully close the liquid piping service valve.
4. Turn on the unit's power switch and start the Cooling Only mode operation.
5. Observe the pressure gauge reading. When it changes 14.2 to 7.1 psig, fully close the gas line LG valve and then immediately turn the unit off. Pump down procedure is complete and all refrigerant will be collected into the outdoor unit.

WARNING

-  Never inhale or handle refrigerant directly. Doing so will cause bodily harm and injury.
- After pump down, power must be turned off before the hose is removed. If the system is operated without the hose connected, air inside the compressor will cause the pressure to increase, and possibly cause an explosion and physical injury.

Note:

Perform Pump Down procedure in the Cooling Only mode.

Disabling Cooling Only Mode

After Pump Down procedure has been performed, Cooling Only mode will need to be disabled, and the system will need to be returned to normal operating mode.

1. Supply power to the system, but system must be OFF with all functions inactive.
2. Enter the Installer mode.
3. Set code to 46.
4. Press ON / OFF button and select the code number 46. Unit will beep to acknowledge that code has been received.
5. Turn off power for a minimum of 30 seconds.
6. Turn power back on to system.

TROUBLESHOOTING

LG SIMS - Self Diagnosis Functions

The SIMS WLAN module and the smart phone app together provide monitoring and troubleshooting capability for LG Duct Free Systems. SIMS function only with LG Duct Free products. LG SIMS can also be used with Single Zone one-to-one configurations such as the Single Zone Wall Mount systems. SIMS app is available for Apple® iPhone® iOS or Android™ smart phone operating systems. Download the latest version from the App Store (iPhone iOS) or Google Play™ store (Android). (Apple and iPhone are trademarks of Apple Inc., registered in the U.S. and other countries. Android and Google Play store are trademarks of Google LLC.) SIMS can display and graph operational data for the air conditioner system including the indoor unit and the outdoor unit. SIMS also displays error codes and a troubleshooting guide. A full copy of the LG SIMS Smart Inverter Monitoring System User's Manual is available on the www.lghvac.com website.

To use SIMS, you must be a trained HVAC service technician familiar with variable refrigerant flow (VRF) systems in general, and with LG's Duct Free System products. You must understand the inverter air conditioning operation cycle, the meaning of the data displayed by SIMS, and how to use the data to troubleshoot the system.

Figure 105: LG SIMS App and WLAN Module.



Figure 106: SIMS WLAN Module to DFS System Example.

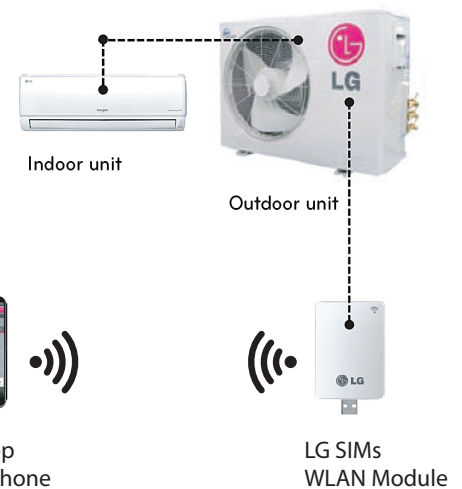

⚠ WARNING

High voltages capable of causing death are used in this equipment. Outdoor unit power remains connected during this procedure. Take extreme caution not to touch electrical components or connections. Failure to observe this warning can result in death or severe injury.

Note:

- The Duct Free System air conditioning system must run for at least 15–20 minutes before data collected by SIMS is valid for troubleshooting.
- The free SIMS app must be correctly installed on the smart phone before using SIMS.
- Some outdoor units have an LGMV extension cable accessed by removing the side handle cover. If the outdoor unit does not have this extension cable, access the LGMV connector by removing the top cover of the outdoor unit.

SIMS App Main Info Screen

The main screen is the first screen displayed after wireless connection is established. Tap the Main Info tab to display current readings regarding the indoor and outdoor unit(s). The Operational Info area of the screen will show active functions or modes by illuminating the light to the right of the function.

Additional Help information can be accessed by tapping the Help Menu buttons at the bottom of this screen.

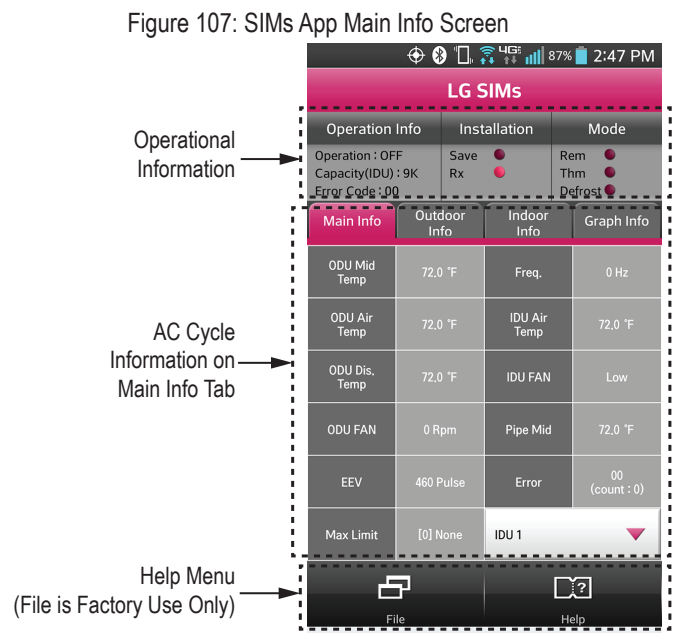

TROUBLESHOOTING

LG SIMS - Self Diagnosis Functions

SIMs App Screens

LG SIMS

Operation Info | Installation | Mode

Operation : OFF | Save Rx | Rem Thm Defrost

Capacity(IDU) : 9K | Rx | Thm | Defrost

Error Code : 00

Main Info | **Outdoor Info** | Indoor Info | Graph Info

Component | Temperature

	Target	Present
Frequency	0 Hz	0 Hz
FAN1 RPM	0 Rpm	0 Rpm
FAN2 RPM	0 Rpm	0 Rpm
DC Link	0 V	285 V
Current	0.0A	Restart Timer 255 S
Voltage	214 V	Comp Mode Stop
EEV Mode	5	EEV 460 Pulse

File | Help

Outdoor Info/Component Screen

Displays the following information:

- Frequency
- FAN1 RPM
- FAN2 RPM
- DC Link
- Current
- Voltage
- EEV Mode
- Restart Timer
- Comp Mode
- EEV

Outdoor Info/Temperature Screen

Displays the following information:

- Inv TD
- Suction
- Discharge
- Cond Mid
- Cond Out
- Heatsink
- Air Temp

LG SIMS

Operation Info | Installation | Mode

Operation : OFF | Save Rx | Rem Thm Defrost

Capacity(IDU) : 9K | Rx | Thm | Defrost

Error Code : 00

Main Info | **Outdoor Info** | Indoor Info | Graph Info

Component | Temperature

	Target	Present
Inv Td	32.0 °F	32.0 °F
Suction	-	-
Discharge	72.0 °F	72.0 °F
Cond Mid	72.0 °F	72.0 °F
Cond Out	-	-
Heatsink	73.0 °F	73.0 °F
Air Temp	71.0 °F	71.0 °F

File | Help

LG SIMS

Operation Info | Installation | Mode

Operation : OFF | Save Rx | Rem Thm Defrost

Capacity(IDU) : 9K | Rx | Thm | Defrost

Error Code : 00

Main Info | Outdoor Info | **Indoor Info** | Graph Info

	#1	#2	#3
Capacity	9		
Operation	OFF		
THM Mode	OFF		
REM Mode	OFF		
FAN	Low		
EEV	460		
Air Temp	72.0 °F		
Pipe-in	71.0 °F		
Pipe-mid	72.0 °F		
Pipe-out	72.0 °F		

File | Help

Indoor Info Tab

Displays the following information:

- Frequency
- Operation
- THM Mode
- REM Mode
- FAN
- EEV
- Air Temp
- Pipe-in
- Pipe-mid
- Pipe-out

Graph Info Tab

This tab has three sub sections:

- IDU - Indoor Unit Temperature graph. Displays IDU information in graph format. Information displayed is for the IDU # selected on the Main screen.
- ODU - Outdoor Unit Temperature and Frequency graph. Displays ODU information in graph format.
- ODU Electric - Outdoor Unit Electric data graph is displayed.

LG SIMS

Operation Info | Installation | Mode

Operation : OFF | Save Rx | Rem Thm Defrost

Capacity(IDU) : 9K | Rx | Thm | Defrost

Error Code : 00

Main Info | Outdoor Info | Indoor Info | **Graph Info**

IDU | ODU | Temp → Elec

Indoor Temp	72.0 °F	Suction Temp	-
Pipe mid Temp	73.0 °F	Pipe in Temp	-
Out air Temp	72.0 °F	Frequency	0 Hz

Graph showing Temperature vs. Time (min)

File | Help

TROUBLESHOOTING

Error Codes

Troubleshooting Using Error Codes

Refer to the table below and on the next two pages for error codes that are generated from the indoor and outdoor units. These codes are the most common. Your particular system might generate additional codes not listed here. Please contact LG Support if you see these types of errors and a simple power cycle has not corrected the issue.

Error Codes

- Indicate different types of unit failures, assists in self-diagnosis and to track the frequency of occurrence.
- Error codes are shown on the control board LEDs of indoor and outdoor units and the SIMs app. Also, check the wired remote controller display first for error codes if present.
- If two or more errors occur simultaneously, the lower error code number is displayed first.
- After error is resolved, the error code does not display.

Decoding the Error Display

The first and second number on the LED indicates error number. Example: 21 = LED1 (Green light) 2x blink, LED2 (Red light) 1x blink.

Error Code Nomenclature Definitions

- MICOM: Non-volatile memory chip where unit setup information is stored.
- EEPROM: Non-volatile memory chip where device identification, size, and factory defined default component operating parameters are stored.

Table 21: Single Zone Wall Mounted Indoor Unit Error Codes.

Error Code	Description	No. of Times Indoor Unit LEDs Blink	
		LED1	LED2
1	Indoor unit room temperature sensor error	1X	-
2	Indoor unit inlet pipe sensor error	2X	-
3	Wired remote control error	3X	-
4	Float switch error (optional)	4X	-
5	Communication error between indoor unit and outdoor unit	-	5X
6	Indoor unit outlet pipe sensor error	6X	-
9	Indoor unit EEPROM error	9X	-
10	Indoor unit BLDC motor fan lock	-	1X
12	Indoor unit middle pipe sensor error	2X	1X
21	DC Peak (IPM Fault); Compressor DC voltage was too high	2X	1X
22	Current Transformer2 (CT2) error; Alternating current (AC) input too high	2X	2X
23	DC Link Low Volt	2X	3X
25	AC Low/High Volt	2X	5X
26	DC Comp Position Error (not providing rotation), Locking	2X	6X
27	PSC Fault; Current to inverter compressor between AC and DC converter circuit too high	2X	7X
28	Inverter compressor DC voltage is too high	2X	8X
29	Inverter compressor amperage is too high	2X	9X
31	Current-to-current transformer (CT) thermistor is too low	3X	1X
32	Inverter Compressor Discharge Pipe (D-Pipe) Overheat	3X	2X
40	CT Sensor Error; Thermistor is disconnected or shorted out	4X	-
41	D-Pipe Sensor INV is disconnected or shorted out	4X	1X
44	Outdoor Air Sensor is disconnected or shorted out	4X	4X
45	Middle thermistor of outdoor unit condenser coil is disconnected or shorted out	4X	5X
46	Outdoor unit suction line thermistor is disconnected or shorted out	4X	6X
48	Outdoor unit coil outlet (liquid line) thermistor is disconnected or shorted out	4X	8X
53	Communication failure from outdoor unit to indoor unit	5X	3X
60	Outdoor unit printed circuit board (PCB) EEPROM check sum error	6X	-
61	Outdoor unit condenser coil temperature is too high	6X	1X
62	Outdoor unit inverter compressor PCB heat sink temperature is too high	6X	2X
63	Condenser coil pipe thermistor temperature is too low	6X	3X
65	Heat sink thermistor has disconnected or has shorted out	6X	5X
67	Outdoor brushless direct current (BLDC) fan motor lock error	6X	7X

TROUBLESHOOTING

Error Codes

Single Zone Wall Mounted Outdoor Unit Error Codes

The Single Zone Wall Mounted outdoor unit error codes are visible on the outdoor unit, as well as from the indoor unit. However, the indoor unit error codes are only visible from the indoor unit and will not display at the outdoor unit. When troubleshooting the system, be sure to verify if the error codes that are being displayed are specific for indoor or outdoor units.

Table 22: Single Zone Wall Mounted Outdoor Unit Error Codes.

Error Code	Description	No. of Times Outdoor Unit LEDs Blink	
		LED1	LED2
21	DC Peak (IPM Fault); Compressor DC voltage was too high	2X	1X
22	Current Transformer2 (CT2) error; Alternating current (AC) input too high	2X	2X
23	DC Link Low Volt	2X	3X
25	AC Low/High Volt	2X	5X
26	DC Comp Position Error (not providing rotation), Locking	2X	6X
27	PSC Fault; Current to inverter compressor between AC and DC converter circuit too high	2X	7X
28	Inverter compressor DC voltage is too high	2X	8X
29	Inverter compressor amperage is too high	2X	9X
31	Current-to-current transformer (CT) thermistor is too low	3X	1X
32	Inverter Compressor Discharge Pipe (D-Pipe) Overheat	3X	2X
40	CT Sensor Error; Thermistor is disconnected or is shorted out	4X	-
41	D-Pipe Sensor INV is disconnected or shorted out	4X	1X
44	Outdoor Air Sensor is disconnected or shorted out	4X	4X
45	Middle thermistor of outdoor unit condenser coil is disconnected or shorted out	4X	5X
46	Outdoor unit suction line thermistor is disconnected or shorted out	4X	6X
48	Outdoor unit coil outlet (liquid line) thermistor is disconnected or shorted out	4X	8X
53	Communication failure from outdoor unit to indoor unit	5X	3X
60	Outdoor unit printed circuit board (PCB) EEPROM check sum error	6X	-
61	Outdoor unit condenser coil temperature is too high	6X	1X
62	Outdoor unit inverter compressor PCB heat sink temperature is too high	6X	2X
63	Condenser coil pipe thermistor temperature is too low	6X	3X
65	Heat sink thermistor has disconnected or has shorted out	6X	5X
67	Outdoor brushless direct current (BLDC) fan motor lock error	6X	7X

Refer to Service Manuals posted on www.lghvac.com for a full description of all error codes and work-arounds.

CAUTIONS FOR REFRIGERANT LEAKS

Cautions for Refrigerant Leaks / Introduction

ASHRAE Standards 15-2010 and 34-2010 offer guidelines that address refrigerant safety and the maximum allowable concentration of refrigerant in an occupied space. Refrigerant will dissipate into the atmosphere, but a certain volume of air is required for this to occur safely. For R410A refrigerant, the maximum allowable concentration is 0.026 lbs./ft³ per 1,000 ft³ of air in an occupied space. Buildings with twenty-four (24) hour occupancy allow half of that concentration.¹

ASHRAE Standards 15 and 34 assume that if a system develops a leak, its entire refrigerant charge will dump into the area where the leak occurs. To meet ASHRAE Standards 15 and 34, calculate the refrigerant concentration that may occur in the smallest room volume on the system, and compare the results to the maximum allowable concentration number (see below for information on how to calculate the refrigerant concentration).¹ Also consult state and local codes in regards to refrigerant safety.

⚠ WARNING

Verify the maximum refrigerant concentration level in the space where the indoor unit will be mounted meets the concentration limit for the application. If the refrigerant leaks and safety limits are exceeded, it could result in personal injuries or death from oxygen depletion.

Note:

Take appropriate actions at the end of HVAC equipment life to recover, recycle, reclaim or destroy R410A refrigerant according to applicable US EPA rules.

To calculate the potential refrigerant concentration level (RCL):

1. Measure the occupied space dimensions (in feet).
2. Calculate the cubic foot volume of air in the smallest occupied space. (To obtain a detailed overview of the RCL, perform the same calculations to the second smallest zone, the third smallest zone until the RCL is obtained for all zones. Also, pay special attention to areas such as basements, etc., where refrigerant cannot dissipate easily.)
3. Divide the refrigerant charge of the Single Zone system serving the area in pounds by the results of step 1.
4. If the calculation indicates that the potential refrigerant concentration level is higher than the allowed RCL, increase the cubic volume of the smallest occupied space or modify the piping system design.
5. The allowable RCL limit for most applications must be equal to or less than 0.026 lbs./ft³. However, in special occupied spaces, such as hospitals and nursing homes, where occupants may have limited mobility, the allowable RCL limit is cut in half. See ASHRAE Standard 34-2007 and local codes for detailed information.¹

Refrigerant Concentration Limit (RCL) Calculations

To calculate total refrigerant amount per system:

Amount of Factory-Charged Refrigerant per Outdoor Unit	+	Amount of Additional Refrigerant Trim Charge	=	Total System Refrigerant Charge
---	----------	---	----------	--

$$\text{RCL (lbs./ft}^3\text{)} = \frac{\text{Total System Refrigerant Charge (lbs.)}}{\text{Volume of Smallest Occupied Space (ft}^3\text{)}}$$

¹American Society of Heating, Refrigeration and Air Conditioning Engineers, Inc. (ASHRAE). Atlanta, GA. ASHRAE, Inc. Information about ASHRAE Standard 15-2010 / 34-2010 and addenda current as of the date of this publication.

INSTALLATION CHECKLIST

Major Component Rough-In

Description	Check
Single Zone outdoor unit was connected properly per local code and the product installation procedures.	
All literature and bagged accessories have been removed from the fan discharge.	
Indoor unit was installed, properly supported, and located indoors in a non-corrosive environment.	
Single Zone unit's gravity condensate drain line was connected and routed where it properly drains away or, if installed in a mechanical room, was connected and properly routed to a drain terminal.	

Piping and Insulation

Description	Check
Single-zone and multi-zone duct-free split systems: ACR copper piping rated at the system working pressure for R410A was used.	
All refrigerant pipes and valves were insulated separately. Insulation is positioned up against the walls of the indoor unit. No gaps shown. Insulation was not compressed at clamps and hangers.	

Brazing Practices

Description	Check
Medical grade (there are 4 available) dry nitrogen for purging during brazing was used (constant 3 psi while brazing).	
15% silver brazing material only.	

Refrigerant Piping

Description	Check
All pipe materials were properly stored, capped, and clean. All burrs were removed after cutting and pipe ends were reamed before brazing.	
During refrigerant pipe installation, for each segment of pipe, a record was made of the pipe length (including expansion loops, offsets, double-back sections), and sizes, as well as the quantity and type of elbows used.	
Expansion loops, coils or other acceptable measures are provided where necessary to absorb temperature-change based pipe movement.	
A torque wrench and backup wrench were used to tighten all flare connections.	
The back side of all flares were lubricated with a small drop of PVE refrigeration oil before tightening flare fittings.	
Ensure all field made flares are 45°. Use factory-supplied flare nuts only.	
Pipe segments were secured to the structure using a combination of fixed and floating clamps, and all wall penetrations were sleeved.	
Pipe insulation was not compressed at any point.	
No oil traps, solenoid valves, sight glasses, filter driers, or any other unauthorized refrigerant specialties were present.	
(Optional) High quality R-410A rated full port ball valves (Schrader between the valve body and the indoor units) used at the indoor unit and at will in the refrigerant piping.	

Condensate Pump / Drain Installation

Description	Check
Condensate drain installed on indoor units. Extended condensate piping material used is acceptable under local code. Insulated to prevent condensation.	
Indoor unit condensate drain pipes were installed correctly.	
Indoor unit with a gravity drain were level or slightly canted toward the drain connection and is supported properly.	
Drain lines are properly insulated to prevent condensation.	

Power Wire and Communication Cables

Description	Check
Power wiring to the Single Zone outdoor unit is solid or stranded, and complies with all local and national electrical codes.	
Power wiring was connected to a single phase 208-230V source.	
Ground wire was installed and properly terminated at the unit.	
The power supplied was clean with voltage fluctuations within specifications. ($\pm 10\%$ of nameplate).	
Power wiring to the Single Zone outdoor unit was installed per all local electrical code requirements.	
Communication / connection (power) wiring from the outdoor unit to the indoor unit is minimum 14 gauge, four-conductor, stranded, shielded or unshielded. If shielded, the wire must be grounded to chassis at the outdoor unit only.	
Wiring to the indoor unit was installed per all local electrical code requirements.	
Communication / connection (power) wiring from the outdoor unit to the indoor unit can be run in the same conduit.	
Communication type RS-485-BUS type.	
22-3 AWG, twisted, stranded, unshielded cable (minimum) was used between the indoor unit and its zone controller (if present). No cables were spliced and no wire caps are present.	
LG-supplied cable was used between the indoor unit and its zone controller. No cables were spliced and no wire caps are present.	
Appropriate crimping tool was used to attach ring or spade terminals at all power wiring and control cable terminations.	
Power and control wires were run in the same conduit (outdoor unit to indoor only) as provided in the product installation manual.	
Power to outdoor unit and power/communications to indoor unit CANNOT be run in the same conduit.	



Inverter

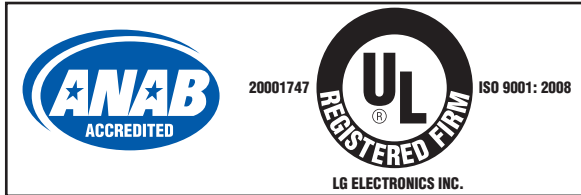

For further technical materials such as submittals, engineering manuals, service manuals, and catalogs, visit www.lghvac.com.



LG Customer Information Center, Commercial Products
1-888-865-3026 USA
Follow the prompts for commercial A/C products.

LG Electronics, U.S.A., Inc.
Air Conditioning Technologies
4300 North Point Parkway
Alpharetta, Georgia 30022
www.lghvac.com

IM_SZ_HighEfficiency_WallMounted_09_23
Supersedes: IM_SZ_HighEfficiency_WallMounted_11_22
IM_SZ_HighEfficiency_WallMounted_10_22
IM_SZ_HighEff_WallMount_HSV5_11_18
IM_SZ_HighEff_WallMount_HSV5_09_18
Supersedes: IM_WallMounted_All_11_15
IM_WallMounted_All_08_15
IM-WallMounted-All-08-14



ENGLISH

FRANÇAIS

ESPAÑOL

OWNER'S MANUAL AIR CONDITIONER

Read this owner's manual thoroughly before operating the appliance and keep it handy for reference at all times.

TYPE: WALL MOUNTED



ENERGY STAR

If Indoor unit are connected with multi split type, It is not Energy Star certified products



MFL69491102
Rev.03_052818

www.lg.com

Copyright © 2017 - 2018 LG Electronics Inc. All Rights Reserved.

TABLE OF CONTENTS

2 TABLE OF CONTENTS

3 SAFETY INSTRUCTIONS

3 IMPORTANT SAFETY INSTRUCTIONS

7 OPERATION

7 Notes for Operation
7 Parts and Functions
8 Wireless Remote Control
13 Restarting the Air Conditioner Automatically
13 Using the Mode Function
15 Using the Jet Mode Function
16 Using the Fan Speed Function
16 Using the Air Flow Direction Function
17 Setting the On/Off Timer
18 Using the Sleep Function (Optional)
18 Using the Simple Timer Function (Optional)
19 Using the Energy Display Function (Optional)
19 Using the Light Off Function (Optional)
19 Using the Comfort Air Function (Optional)
20 Using the Energy Saving Function (Optional)
20 Using the Energy Control Function (Optional)
21 Using Special Functions

24 SMART FUNCTIONS

24 Using LG SmartThinQ Application

27 MAINTENANCE

29 Clean the Air Filter
30 Clean the 3M and Triple Filter (Optional)

31 TROUBLESHOOTING

35 WARRANTY (USA)

37 WARRANTY (CANADA)

SAFETY INSTRUCTIONS

READ ALL INSTRUCTIONS BEFORE USE

Your safety and the safety of others are very important.

We have provided many important safety messages in this manual and on your appliance. Always read and follow all safety messages.



This is the safety alert symbol.

This symbol alerts you to potential hazards that can kill or injure you and others.

All safety messages will follow the safety alert symbol and either the word WARNING, or CAUTION.



WARNING

If you do not follow instructions, it could result in death or serious injury.



CAUTION

If you do not follow instructions, it could result in minor or moderate injury or damage to the product.

All safety messages will tell you what the potential hazard is, tell you how to reduce the chance of injury, and tell you what may happen if the instructions are not followed.

IMPORTANT SAFETY INSTRUCTIONS



WARNING

To reduce the risk of explosion, fire, death, electric shock, injury or scalding to persons when using this product, follow basic precautions, including the following:

- Installation or repairs made by unauthorized persons can pose hazards to you and others.
- Installation MUST conform to the local building codes or, in the absence of local codes, the National Electrical Code NFPA 70/ANSI C1-1003 or current edition and Canadian Electrical Code Part1 CSA C.22. 1.
- The information contained in the manual is intended for use by a qualified service technician who is familiar with the safety procedures and equipped with the proper tools and test instruments.
- Failure to read and follow all instructions in this manual can result in equipment malfunction, property damage, personal injury and/or death.
- When the power cord is to be replaced, the replacement work shall be performed by authorized personnel using only genuine replacement parts.
- This appliance is not intended for use by persons (including children) with reduced physical, sensory or mental capabilities, or lack of experience and knowledge, unless they have been given supervision or instruction concerning use of the appliance by a person responsible for their safety. Children should be supervised to ensure that they do not play with the appliance.

Installation

- Do not install the air conditioner on an unstable surface or in a place where there is danger of it falling.
- Contact an authorized service center when installing or relocating the air conditioner.
- Install the panel and the cover of the control box safely.
- Do not install the air conditioner in a place where flammable liquids or gases such as gasoline, propane, paint thinner, etc., are stored.
- Make sure that the pipe and the power cable connecting the indoor and outdoor units are not pulled too tight when installing the air conditioner.
- Use standard circuit breaker and fuse that conform to the rating of the air conditioner.
- Do not input air or gas into the system except with the specific refrigerant.
- Use non-flammable gas (nitrogen) to check for leak and to purge air; using compressed air or flammable gas may cause fire or explosion.
- The indoor/outdoor wiring connections must be secured tightly, and the cable should be routed properly so that there is no force pulling the cable from the connection terminals. Improper or loose connections can cause heat generation or fire.
- Install dedicated electric outlet and circuit breaker before using the air conditioner.
- Do not connect the ground wire to a gas pipe, a lightning rod, or a telephone ground wire.
- If the supply cord is damaged, it must be replaced by the manufacturer, its service agent or similarly qualified person in order to avoid a hazard.

Operation

- Be sure to use only those parts listed in the service parts list. Never attempt to modify the equipment.
- Make sure that children do not climb on or hit the outdoor unit.
- Dispose of the batteries in a place where there is no danger of fire.
- Use only the refrigerant specified on the air conditioner label.
- Cut off the power supply if there is any noise, smell, or smoke coming from the air conditioner.
- Do not leave flammable substances such as gasoline, benzene, or thinner near the air conditioner.
- Contact an authorized service center when the air conditioner is submerged by flood waters.
- Do not use the air conditioner for an extended period of time in a small place without proper ventilation.
- In the event of a gas leak (such as Freon, propane gas, LP gas, etc.) ventilate sufficiently before using the air conditioner again.
- To clean the interior, contact an authorized service center or dealer. Using harsh detergents may cause corrosion or damage to the unit.

- Be sure to ventilate sufficiently when the air conditioner and a heating appliance such as a heater are used simultaneously.
- Do not block the inlet or outlet of air flow.
- Do not insert hands or other objects through the air inlet or outlet while the air conditioner is operating.
- Make sure that the power cable is neither dirty, loose, nor broken.
- Never touch, operate, or repair the air conditioner with wet hands.
- Do not place any objects on the power cable.
- Do not place a heater or other heating appliances near the power cable.
- Do not modify or extend the power cable. Scratches or peeling insulation on the power cables may result in fire or electric shock, and should be replaced.
- Cut off the power supply immediately in the event of a blackout or a thunderstorm.
- Take care to ensure that power cable could not be pulled out or damaged during operation.
- Do not touch refrigerant pipe, water pipe and any internal parts while the unit is operating or immediately after operation.

Maintenance

- Do not clean the appliance by spraying water directly onto the product.
- Before cleaning or performing maintenance, disconnect the power supply and wait until the fan stops.

CAUTION

To reduce the risk of minor injury to persons, malfunction, or damage to the product or property when using this product, follow basic precautions, including the following:

Installation

- Do not install the air conditioner in an area where it is directly exposed to sea wind (salt spray).
- Install the drain hose properly for the smooth drainage of water condensation.
- Exercise caution when unpacking or installing the air conditioner.
- Do not touch the leaking refrigerant during installation or repair.
- Transport the air conditioner with two or more people or use a forklift.
- Install the outdoor unit such that it is protected from direct sunlight. Do not place the indoor unit in a place where it is directly exposed to sunlight via the windows.
- Safely dispose of packing materials such as screws, nails or batteries using proper packaging after installation or repair.
- Install the air conditioner in a place where the noise from the outdoor unit or the exhaust fumes will not inconvenience the neighbors. Failure to do so may result in conflict with the neighbors.

Operation

- Remove the batteries if the remote control is not to be used for an extended period of time.
- Make sure that the filter is installed before operating the air conditioner.
- Be sure to check if there is a refrigerant leak after installing or repairing the air conditioner.
- Follow the standards of the corresponding region or country for handling the refrigerant and the air conditioner and for disassembling the air conditioner.
- Do not place any object on the air conditioner.
- Never mix different types of batteries, or old and new batteries for the remote control.
- Do not let the air conditioner run for a long time when humidity is very high or when a door or a window has been left open.
- Stop using the remote control if there is a fluid leak in the battery. If your clothes or skin are exposed to the leaking battery fluid, wash off with clean water.
- Do not expose people, animals, or plants to the cold or hot wind from the air conditioner for extended periods of time.
- If the leaking battery fluid has been swallowed, rinse the inside of the mouth thoroughly and consult a doctor.
- Do not drink the water drained from the air conditioner.
- Do not use the product for special purposes, such as preserving foods, works of art, and etc. It is an air conditioner for consumer purposes, not a precision refrigeration system. There is risk of damage or loss of property.
- Do not recharge or disassemble the batteries.

Maintenance

- Never touch the metal parts of the air conditioner when removing the air filter.
- Use a sturdy stool or ladder when cleaning, maintaining, or repairing the air conditioner at a height.
- Never use strong cleaning agents or solvents when cleaning the air conditioner or spray water. Use a smooth cloth.

OPERATION

Notes for Operation

Suggestion for Energy Saving

- Do not over-cool the space. This may be harmful for your health and may consume more electricity.
- Block sunlight with blinds or curtains while you are operating the air conditioner.
- Keep doors or windows closed tightly while you are operating the air conditioner.
- Adjust the direction of the air flow vertically or horizontally to circulate indoor air.
- Speed up the fan to cool or warm indoor air quickly, within a short period of time.
- Open windows regularly for ventilation. The indoor air quality may deteriorate if the air conditioner is used for long durations.
- Clean the air filter once every 2 weeks. Dust and impurities collected in the air filter may block the air flow or reduce the unit performance.

Parts and Functions

Indoor Unit

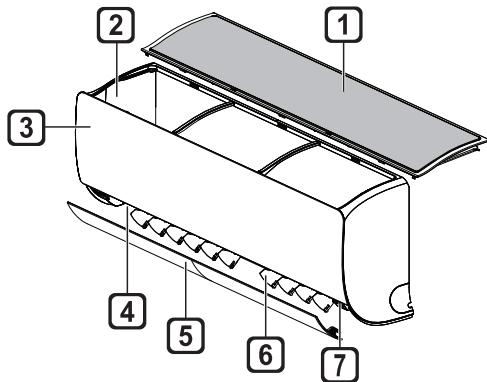

- ① Air Filter
- ② Air Intake
- ③ Front Cover
- ④ Air Outlet
- ⑤ Air Deflector (Horizontal Vane)
- ⑥ Air Deflector (Vertical Louver)
- ⑦ On/Off Button

Outdoor Unit

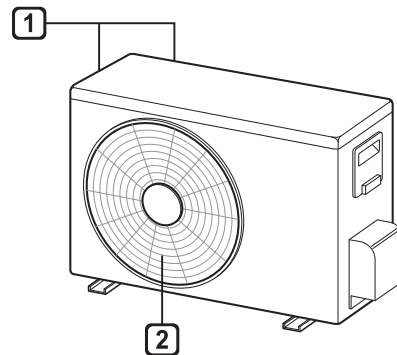

- ① Air Intake Vents
- ② Air Outlet Vents

NOTE

- The number and location of operation lamps may vary according to the model of the air conditioner.
- The feature may be changed according to the type of model.

Wireless Remote Control

Inserting Batteries

If the display screen of the remote control begins to fade, replace the batteries. Insert AAA (1.5 V) batteries before using the remote control.

- 1 Remove the battery cover.

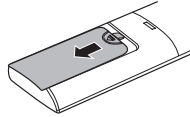

- 2 Insert the new batteries and make sure that the + and - terminals of the batteries are installed correctly.

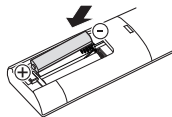

Installing the Remote Control Holder

To protect the remote control, install the holder where there is no direct sunlight.

- 1 Choose a safe and easily accessible location.
- 2 Fix the holder by fastening 2 screws firmly with a screwdriver.

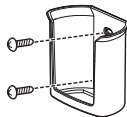

Operating Method

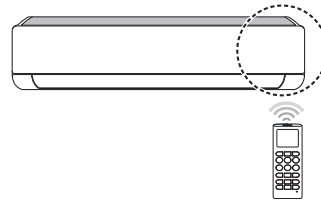

Point the remote control towards the signal receiver at the right side of the air conditioner to operate it.



NOTE

- The remote control may operate other electronic devices if it is directed towards them. Make sure to point the remote control towards the air conditioner signal receiver.
- For proper operation, use a soft cloth to clean the signal transmitter and receiver.
- In case of a function not provided in the product, no buzzer sound occurs from the product when a button for such function on the remote control is pressed except for Air Flow Direction (SWING), Energy Display (kW_[3-5]), Air Purification function ().

Setting the Current Time

- 1 Insert batteries.
 - The icon below blinks at the bottom of the display screen.
- 
- 2 Press  or  button to select the minutes.
 - 3 Press **SET/CANCEL** button to finish.

NOTE

- The On/Off Timer is available after setting the current time.

Using the °C/°F Conversion Function (Optional)

This function changes unit between °C and °F

- Press and hold  button about 5 seconds.

Operating the Air Conditioner without the Remote Control

You can use the **ON/OFF** button of the indoor unit to operate the air conditioner when the remote control is unavailable.

- 1 Open the front cover (Type2) or horizontal vane (Type1).
- 2 Press the **ON/OFF** button.

Type1

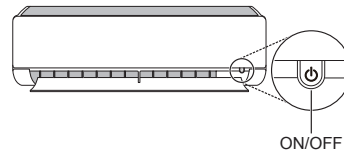

Type2

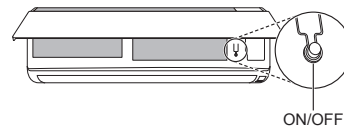

NOTE

- The stepping motor may be broken, if the horizontal vane opens rapidly.
- The fan speed is set to high.
- The feature may be changed according to the type of model.
- The temperature cannot be altered when using this emergency **ON/OFF** button.
- For cooling & heating models, the temperature is set from 22 °C to 24 °C

Using Wireless Remote Control

You can operate the air conditioner more conveniently with the remote control.

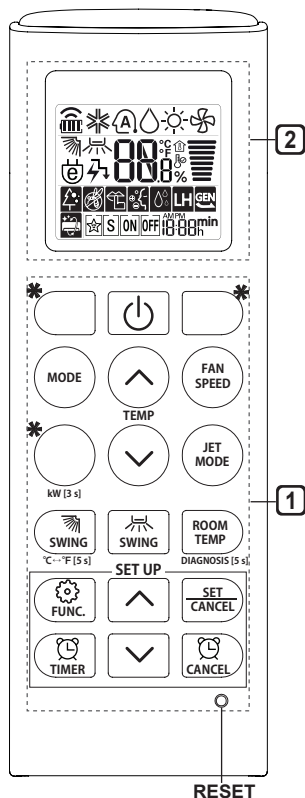

1 Button	2 Display Screen	Description	Available Function	
			Single Split	Multi
	-	To turn on/off the air conditioner.	<input type="checkbox"/>	<input type="checkbox"/>
	88°C	To adjust the desired room temperature in cooling, heating or auto changeover mode.	<input type="checkbox"/>	<input type="checkbox"/>
MODE		To select the cooling mode.	<input type="checkbox"/>	<input type="checkbox"/>
		To select the heating mode.	<input type="checkbox"/>	<input type="checkbox"/>
		To select the dehumidification mode.	<input type="checkbox"/>	<input type="checkbox"/>
		To select the fan mode.	<input type="checkbox"/>	<input type="checkbox"/>
		To select the auto changeover/auto operation mode.	<input type="checkbox"/>	<input type="checkbox"/>
JET MODE	Po	To change room temperature quickly.	<input type="checkbox"/>	<input type="checkbox"/>
FAN SPEED		To adjust the fan speed.	<input type="checkbox"/>	<input type="checkbox"/>
		To adjust the air flow direction vertically or horizontally.	<input type="checkbox"/>	<input type="checkbox"/>

NOTE



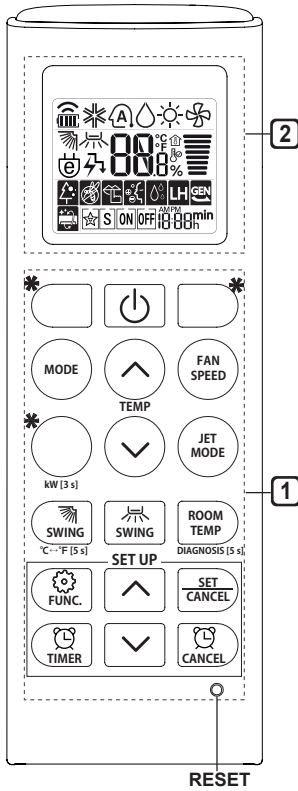



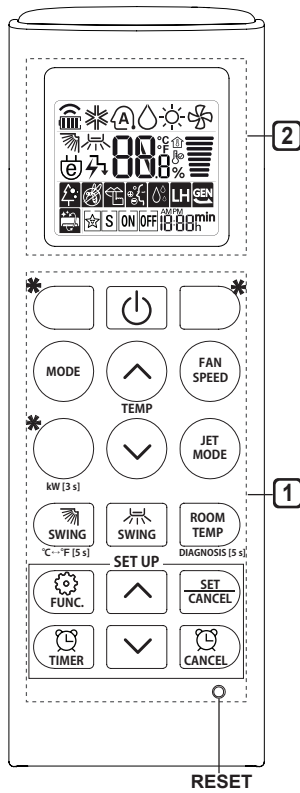

- * buttons may be changed according to the type of model.
- When connected to the Multi Outdoor unit, the Energy Display, Energy Control, Silent and Smart Diagnosis function may not be supported.



1 Button	2 Display Screen	Description	Available Function	
			Single Split	Multi
	S 	To turn on/off air conditioner automatically at desired time.	○	○
SET/ CANCEL	-	To set/cancel the special functions and timer.	○	○
	-	To cancel the timer settings.	○	○
	-	To adjust time.	○	○
*LIGHT OFF	-	To set the brightness of the display on the indoor unit.	○	○
ROOM TEMP		To display the room temperature.	○	○
°C↔°F [5 s]	°C °F	To change unit between °C and °F	○	○
*ENERGY SAVING		To minimize power consumption.	○	○
*COMFORT AIR		To adjust the air flow to deflect wind.	○	○
kW [3 s]	-	To set whether or not to display information regarding energy.	○	X
*ENERGY CTRL	00 %	To bring the effect of the power saving.	X	X
*COMFORT SLEEP		To make a comfortable sleeping environment.	○	X
DIAGNOSIS [5 s]	-	To conveniently check maintenance information of a product.	○	X

12 OPERATION



1 Button	2 Display Screen	Description	Available Function	
			Single Split	Multi
		To purify the air by removing particles that enters the indoor unit.	X	X
		To reduce noise from outdoor units.	X	X
		To keep your skin moisturized by generating ion clusters.	X	X
		To lower indoor humidity quickly.	X	X
		To maintain a minimum room temperature and prevent objects in the room from freezing.	X	X
		To scare away a mosquito.	X	X
		To remove moisture generated inside the indoor unit.	O	O
		To make a comfortable sleeping environment.	X	X
RESET	-	To initialize the remote control settings.	O	O

NOTE

- Some functions may not be supported, depending on the model.
- * buttons may be changed according to the type of model.
- Press the **SET/CANCEL** button to operate the selected **FUNC.**

Restarting the Air Conditioner Automatically

When the air conditioner is turned on again after a power failure, this function restores the previous settings.

Disabling Auto Restart

- 1 Open the front cover (Type2) or horizontal vane (Type1).
- 2 Press the **ON/OFF** button and hold it for 6 seconds, then the unit will beep twice and the lamp will blink twice 4 times.
 - To re-enable the function, press the **ON/OFF** button and hold it for 6 seconds. The unit will beep twice and the lamp will blink 4 times.

Type1

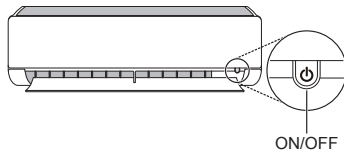

Type2

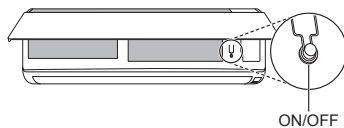

NOTE

- The feature may be changed according to the type of model.
- If you press and hold the **ON/OFF** button for 3 – 5 seconds, instead of 6 seconds, the unit will switch to the test operation. In the test operation, the unit blows out strong cooling air for 18 minutes and then returns to factory default settings.

Using the Mode Function

This function allows you to select the desired function.

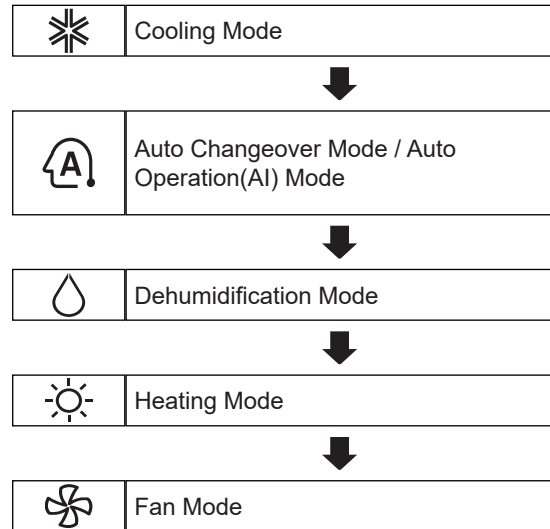



Cooling Mode

- 1 Turn the appliance on.
- 2 Press **MODE** button repeatedly to select the Cooling Mode.
 - ❄️ is displayed on the display screen.
- 3 Press **▲** or **▼** button to set the desired temperature.

Auto Operation (Artificial Intelligence)

Multi Model



In this operation mode, the system is automatically operated by the electronic controls.

- 1 Turn the appliance on.
- 2 Press **MODE** button repeatedly to select the Auto Operation.
 -  is displayed on the display screen.
- 3 Press  or  button to set the desired temperature.
- 4 Press **FAN SPEED** button to adjust the fan speed.

Auto Changeover Mode

Single Split Model

This mode changes the mode automatically to maintain the set temperature at ± 2 °C

- 1 Turn the appliance on.
- 2 Press **MODE** button repeatedly to select the Auto Changeover Mode.
 -  is displayed on the display screen.
- 3 Press  or  button to set the desired temperature.

Dehumidification Mode



This mode removes excess moisture from a highly humid environment or during the rainy season, in order to prevent mildew from setting in. This mode adjusts the room temperature and the fan speed automatically to maintain the optimal level of humidity.

- 1 Turn the appliance on.
- 2 Press **MODE** button repeatedly to select the Dehumidification Mode.
 -  is displayed on the display screen.

NOTE

- In this mode you cannot adjust the room temperature, it is adjusted automatically.
- The room temperature is not displayed on the display screen.

Heating Mode

- 1 Turn the appliance on.
- 2 Press **MODE** button repeatedly to select the Heating Mode.
 -  is displayed on the display screen.
- 3 Press  or  button to set the desired temperature.

NOTE

-  will be displayed on the indoor unit when defrosting is operating.
- Furthermore, this indication will be displayed on the indoor unit:
 - When preheating is operating.
 - When the room temperature has been reached to the set temperature.

Fan Mode

This mode only circulates the indoor air without changing the room temperature.

- 1 Turn the appliance on.
- 2 Press **MODE** button repeatedly to select the Fan Mode.
 -  is displayed on the display screen.
- 3 Press **FAN SPEED** button to adjust the fan speed.

Using the Jet Mode Function





Changing Room Temperature Quickly

This function allows you to cool indoor air quickly during the summer or warm it quickly during winter.

- The Jet Mode function is available with Cooling, Heating and Dehumidification Mode.

- 1 Turn the appliance on.
- 2 Press **MODE** button repeatedly to select the desired mode.
- 3 Press **JET MODE** button.
 -  is displayed on the display screen.





NOTE

- Jet Heating Mode is not available on some models.
- In Jet Cooling Mode, strong air blows out for 30 minutes.
 - After 30 minutes later, setting temperature is maintaining 18 °C
 - If you want to change the temperature, Press  or  button to set the desired temperature.
- In Jet Heating Mode, strong air blows out for 30 minutes.
 - After 30 minutes later, setting temperature is maintaining 30 °C
 - If you want to change the temperature, Press  or  button to set the desired temperature.
- This function may operate differently from the remote control display.

Using the Fan Speed Function

Adjusting the Fan Speed

- Press **FAN SPEED** button repeatedly to adjust the fan speed.

Display Screen	Speed
	High
	Medium - High
	Medium
	Medium - Low
	Low
-	Natural Wind

NOTE

- The fan speed of Natural Wind adjusts automatically.







- The fan speed icons are displayed on some indoor units.

F1 → F2 → F3 → F4 → F5



- Indoor unit display is displayed only 5 seconds and return to the setting temperature on some models.

Using the Air Flow Direction Function

This function adjusts the direction of the air flow vertically (horizontally).

- Press   button repeatedly and select the desired direction.
 - Select   to adjust the direction of the air flow automatically.

NOTE

- Adjusting the air flow direction horizontally may not be supported, depending on the model.
- Adjusting the air deflector arbitrarily may cause product failure.
- If you restart the air conditioner, it starts to operate with the previously set direction of air flow, so the air deflector may not match the icon displayed on the remote control. When this occurs, press  or  button to adjust the direction of the air flow again.
- This function may operate differently from the remote control display.



Setting the On/Off Timer

This function sets the air conditioner to turn on/off automatically at desired time.

Setting the On Timer

- 1 Press  button repeatedly.
 - The icon below blinks at the bottom of the display screen.



- 2 Press  or  button to select the minutes.
- 3 Press **SET/CANCEL** button to finish.
 - After setting the timer, current time and  icon are displayed on the display screen indicating that the desired time is set.

Canceling the On Timer

- 1 Press  button repeatedly.
 - The icon below blinks at the bottom of the display screen.





- 2 Press **SET/CANCEL** button to cancel the setting.

Setting the Off Timer

- 1 Press  button repeatedly.
 - The icon below blinks at the bottom of the display screen.



- 2 Press  or  button to select the minutes.
- 3 Press **SET/CANCEL** button to finish.
 - After setting the timer, current time and  icon are displayed on the display screen indicating that the desired time is set.

NOTE

- This function is disabled when you set Simple Timer.

Canceling the Off Timer

- 1 Press  button repeatedly.
 - The icon below blinks at the bottom of the display screen.



- 2 Press **SET/CANCEL** button to cancel the setting.

Canceling the Timer Setting



- Press  button to cancel all timer settings.

Using the Sleep Function (Optional)

This function turns off the air conditioner automatically when you go to sleep.

- 1 Turn the appliance on.
- 2 Press  button repeatedly.
 - The icon below blinks at the bottom of the display screen.



- 3 Press  or  button to select the hour (up to 7 hours).
- 4 Press **SET/CANCEL** button to finish.
 -  is displayed on the display screen.

NOTE



-  is displayed on some indoor units.
- Indoor unit display is displayed from 1H to 7H which is displayed only 5 seconds and then return to the setting temperature.
- In the Cooling and Dehumidification Mode, the temperature increases by 1 °C after 30 minutes and additional 1 °C after another 30 minutes for a more comfortable sleep.
- The temperature increases up to 2 °C from the preset temperature.
- Although the remark for fan speed on the display screen may be changed, the fan speed is adjusted automatically.

Using the Simple Timer Function (Optional)

This function turns off the air conditioner automatically when you go to sleep.

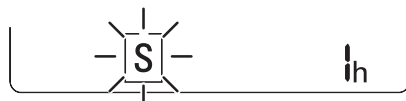
- 1 Turn the appliance on.
- 2 Press  button repeatedly.
 - The icon below blinks at the bottom of the display screen.



- 3 Press  or  button to select the hour (up to 7 hours).
- 4 Press **SET/CANCEL** button to finish.
 -  is displayed on the display screen.



NOTE

- This function is disabled when you set Off Timer.

Using the Energy Display Function (Optional)

This function displays the amount of electricity generated on the indoor display as the product operates.

Display the Current Energy Usage

- 1 Turn the appliance on.
- 2 Press  button and hold it about 3 seconds.
 - The instantaneous power consumption () is displayed for a while on some indoor units.

NOTE

- It is not displayed on the wireless remote control.
- The unit of the displayed value is kW.
- If it is more than 99 kW, which is the range of expression, maintain it as 99 kW.
- Display wattage under 10 kW with 0.1 kW unit, and display one over 10 kW with 1 kW unit.
- The actual power may differ from the power displayed.
- When connected to the Multi Outdoor unit, this function may not be supported.

Using the Light Off Function (Optional)

Display Screen Brightness

You can set the brightness of the indoor unit display screen.

- Press **LIGHT OFF** button.



NOTE

- Turn on/off the Display screen.



Using the Comfort Air Function (Optional)

Comfort Vane Operation

This function conveniently sets the vane to a preset position to deflect the supply air away from blowing directly onto the occupants in the room.

- 1 Turn the appliance on.
- 2 Press **COMFORT AIR** button repeatedly and select the desired direction.
 -  or  is displayed on the display screen.

NOTE

-  or  is displayed on some indoor units.
- This function is disabled when you press **MODE** or **JET MODE** button.
- This function is disabled and auto swing of vertical direction is set up when you press  button.
- When this function is off, the horizontal vane operates automatically depending on the set mode.

Using the Energy Saving Function (Optional)







This function minimizes power consumption during Cooling and increases the set temperature to the optimal level for a more comfortable environment. The temperature automatically settles at 22 °C if desired temperature is below 22 °C. The temperature remains constant if it is above 22 °C.

- 1 Turn the appliance on.
- 2 Press **MODE** button repeatedly to select the Cooling Mode.
- 3 Press **ENERGY SAVING** button.
 -  is displayed on the display screen.

Using the Energy Control Function (Optional)

- 1 Turn the appliance on.
- 2 Press **ENERGY CTRL** button.
 - Press **ENERGY CTRL** button repeatedly to select each step.







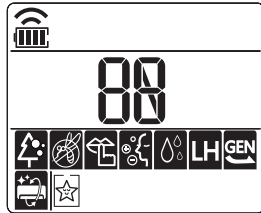

NOTE

- 1 step : The power Input is decreased by 20 % compared to rated power input.
 -  % is displayed on the display screen.
- 2 step : The power Input is decreased by 40 % compared to rated power input.
 -  % is displayed on the display screen.
- 3 step (Optional) : The power Input is decreased by 60 % compared to rated power input.
 -  % is displayed on the display screen.
-  (1 step),  (2 step) is displayed on some indoor units.
- This function is available with Cooling Mode.
- Capacity may decrease when Energy Control mode is selected.
- Desired temperature is displayed about 5 seconds if you press **FAN SPEED**,  or  button.
- Room temperature is displayed about 5 seconds if you press **ROOM TEMP** button.

Using Special Functions

- 1 Turn the appliance on.
- 2 Press **FUNC** button repeatedly to select the desired function.
- 3 Press **SET/CANCEL** button to finish.



Display Screen	Description	Available Function	
		Single Split	Multi
	To purify the air by removing particles that enters the indoor unit.	X	X
	To reduce noise from outdoor units.	X	X
	To keep your skin moisturized by generating ion clusters.	X	X
	To lower indoor humidity quickly.	X	X
	To maintain a minimum room temperature and prevent objects in the room from freezing.	X	X
	To scare away a mosquito.	X	X
	To remove moisture generated inside the indoor unit.	O	O
	To make a comfortable sleeping environment.	X	X

NOTE

- Some functions may not be supported, depending on the model.
- Some functions may operate differently from the remote control display.

Canceling Special Functions

- 1 Press **FUNC** button repeatedly to select the desired function.
- 2 Press **SET/CANCEL** button to cancel the function.

Using the Air Purification Function

These functions supply clean and fresh air by ion particles and the filter.

Function	Display	Description
Ionizer		Ion particles from ionizer sterilize the aerial bacteria and other harmful substances.
Plasma		It removes microscopic contaminants from the intake air completely to supply clean and fresh air.

NOTE

- You can use this function without turning the air conditioner on.
- Both the plasma lamp and the cooling lamp light up while Smoke Away/Plasma is in operation on some models.
- Do not touch ionizer during operation.
- This function may operate differently from the remote control display.

Using the Silent Function (Optional)

This function prevents potential claims by neighbors, reducing noise from outdoor units.

-  is displayed on the display screen.

NOTE

- This function is disabled when you press **MODE** or **ENERGY CTRL** or **JET MODE** button.
- This function is available with Cooling, Heating, Auto Changeover, Auto Operation Mode.

Using the Ion Care Function (Optional)

This function keeps your skin moisturized by generating ion clusters which is absorbed into the surface of skin.

-  is displayed on the display screen about 3 seconds.

NOTE

- This function is available with Cooling, Fan Mode and Air Purification function.

Using the Jet Dry Function (Optional)

This function maximizes the performance of dehumidification.

-  are displayed on the display screen.

NOTE



- This function is available with Cooling, Dehumidification, Auto Operation, Fan Mode and Air Purification function.
- This function is not available with Sleep function.
- This function is disabled when you press **MODE** button.

Using the Low Heating Function (Optional)

This function operates the heating system to maintain a minimum room temperature and prevent objects in the room from freezing where there is no permanent resident, such as a vacation.

-  are displayed on the display screen.

NOTE

- This function is available with Heating Mode.
- During LH operation, when you press buttons such as , , **MODE**, **FAN SPEED**, and then return to Heating Mode, 30 °C high speed.
- If **JET MODE** button is pressed during LH operation, this function is disabled and Power Heating Mode is operated immediately. (only for power heating model)
- In case an error occurred, operation can be interrupted for the protection of the product.
- **COMFORT AIR** and  button cannot be used while the LH function is in operation.

Using the Mosquito Away Function (Optional)

This function fans away mosquitos by generating a high-frequency wave.

-  is displayed on the display screen.

NOTE

- You can use this function without turning the air conditioner on.
-  is displayed on some indoor units.

Using the Auto Clean Function

In the Cooling and Dehumidification Mode, moisture is generated inside the indoor unit. This function removes such moisture.

-  is displayed on the display screen.

NOTE

- Some functions cannot be used while the Auto Clean function is in operation.
- If you turn off the unit, the fan continues to run for 30 minutes and cleans the inside of the indoor unit.

Using the Comfort Sleep Function (Optional)

This function operates the air conditioner automatically to make the comfortable sleep environment.

-  are displayed on the display screen.

NOTE

- This function is available with Cooling Mode.
- The vane stops swing and sets indirect airflow angle, after 30 minutes from start even though the room temperature doesn't decrease to optimal temperature to sleep.
- It is possible that a comfortable sleep environment is different according to the people.

SMART FUNCTIONS

Using LG SmartThinQ Application

Things to check before using LG SmartThinQ

- For appliances with the  logo
- 1 Check the distance between the appliance and the wireless router (Wi-Fi network).
 - If the distance between the appliance and the wireless router is too far, the signal strength becomes weak. It may take a long time to register or installation may fail.
 - 2 Turn off the **Mobile data** or **Cellular Data** on your smartphone.
 - For iPhones, turn data off by going to **Settings** → **Cellular** → **Cellular Data**.

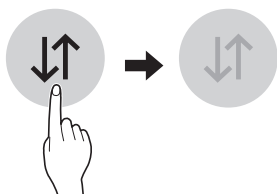

- 3 Connect your smartphone to the wireless router.

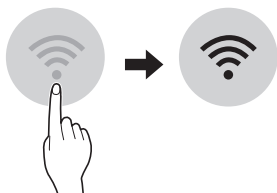

NOTE

- To verify the Wi-Fi connection, check that **Wi-Fi**  icon on the control panel is lit.
- The appliance supports 2.4 GHz Wi-Fi networks only. To check your network frequency, contact your Internet service provider or refer to your wireless router manual.
- LG SmartThinQ is not responsible for any network connection problems or any faults, malfunctions, or errors caused by network connection.
- If the appliance is having trouble connecting to the Wi-Fi network, it may be too far from the router. Purchase a Wi-Fi repeater (range extender) to improve the Wi-Fi signal strength.
- The Wi-Fi connection may not connect or may be interrupted because of the home network environment.
- The network connection may not work properly depending on the Internet service provider.
- The surrounding wireless environment can make the wireless network service run slowly.
- The appliance cannot be registered due to problems with the wireless signal transmission. Unplug the appliance and wait about a minute before trying again.
- If the firewall on your wireless router is enabled, disable the firewall or add an exception to it.
- The wireless network name (SSID) should be a combination of English letters and numbers. (Do not use special characters.)
- Smartphone user interface (UI) may vary depending on the mobile operating system (OS) and the manufacturer.
- If the security protocol of the router is set to **WEP**, you may fail to set up the network. Please change it to other security protocols (**WPA2** is recommended) and register the product again.

Installing LG SmartThinQ

Search for the LG SmartThinQ application from the Google Play Store or Apple App Store on a smart phone. Follow instructions to download and install the application.

Wi-Fi Function

- For appliances with the  logo

Communicate with the appliance from a smart phone using the convenient smart features.

Smart Diagnosis™

If you use the Smart Diagnosis function, you will be provided with the useful information such as a correct way of using the appliance based on the pattern of use.

Settings

Allows you to set various options on the appliance and in the application.

NOTE

- If you change your wireless router, Internet service provider, or password, delete the registered appliance from the LG SmartThinQ application and register it again.
- The application is subject to change for appliance improvement purposes without notice to users.
- Functions may vary by model.



Open Source Software Notice Information

To obtain the source code under GPL, LGPL, MPL, and other open source licenses, that is contained in this product, please visit <http://opensource.lge.com>.

In addition to the source code, all referred license terms, warranty disclaimers and copyright notices are available for download.

LG Electronics will also provide open source code to you on CD-ROM for a charge covering the cost of performing such distribution (such as the cost of media, shipping, and handling) upon email request to opensource@lge.com. This offer is valid for a period of three years after our last shipment of this product. This offer is valid to anyone in receipt of this information.

Smart Diagnosis™ Using a Smart Phone

- For appliances with the  or  logo

Use this function if you need an accurate diagnosis by an LG Electronics customer information centre when the appliance malfunctions or fails.

Smart Diagnosis™ can not be activated unless the appliance is connected to power. If the appliance is unable to turn on, then troubleshooting must be done without using Smart Diagnosis™.

NOTE

- Be sure to keep ambient noise to a minimum or the phone may not correctly receive the buzzer beeps from the indoor unit.
- When connected to the Multi Outdoor unit, this function may not be supported.

MAINTENANCE

⚠ WARNING

- Before cleaning or performing maintenance, disconnect the power supply and wait until the fan stops.

If the air conditioner will not be used for an extended period of time, dry the air conditioner to maintain it in best condition. Clean the product regularly to maintain optimal performance and to prevent possible breakdown.

- Dry the air conditioner in Fan mode for 3 to 4 hours and disconnect the power. There may be internal damage if moisture is left in its components.
- Before using the air conditioner again, dry the inner components of the air conditioner in Fan mode for 3 to 4 hours. This will help to remove the odor generated from moisture.

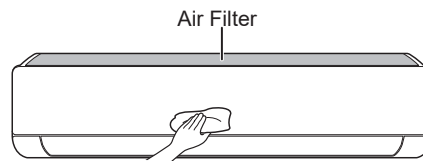

- The feature may be changed according to the type of model.

Type	Description	Interval
Air filter	Clean with a vacuum or hand wash.	2 weeks
Triple filter	Clean with a vacuum or brush.	Every 3 months
3M filter	Clean with a vacuum or brush.	Every 6 months
Ionizer (Optional)	Use dry cotton bud to remove any dust.	Every 6 months
Indoor unit	Clean the Indoor unit surface by using a soft, dry cloth.	Regularly
	Have a professional clean the condensate drain pan.	Once a year
	Have a professional clean the condensate drain pipe.	Every 4 months
	Replace the remote control batteries.	Once a year
Outdoor unit	Have a professional clean the heat exchanger coils and the panel vents. (Consult with technician.)	Once a year
	Have a professional clean the fan.	Once a year
	Have a professional clean the condensate drain pan.	Once a year
	Have a professional verify that all the fan assembly is firmly tightened.	Once a year
	Clean the electric components with air.	Once a year

NOTE

- Never use water that is higher than 40 °C when you clean the filters. It may cause deformation or discoloration.
- Never use volatile substances when you clean the filters. They may damage the surface of the product.
- Do not wash the 3M filter with water, because the filter can be damaged (Optional).
- Do not wash the Triple filter with water, because the filter can be damaged (Optional).

Clean the Air Filter

Clean the air filters once every 2 weeks, or more, if necessary.

NOTE

- The air filter can be broken when it is bent.
- When the air filter is not assembled correctly, dust and other substances can enter into the indoor unit.

Type1

If you look at the indoor unit from above it, can assemble the top filter easily.

- 1 Turn off the power to the unit.
- 2 Hold the knobs of the air filter, lift it up slightly.

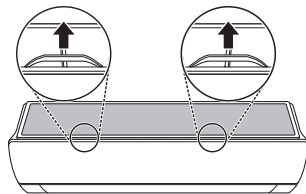

- 3 Remove it from the indoor unit.

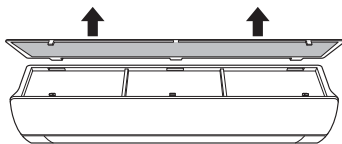

- 4 Clean the filter with a vacuum cleaner or with lukewarm water with neutral detergent.
- 5 Dry the filter in the shade.
- 6 Insert the hooks of the air filter into the front cover.

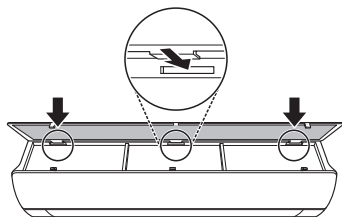

- 7 Push down hooks to assemble the air filter.

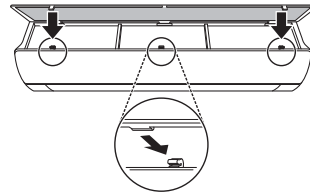

- 8 Check the side of the front cover for correct assembly of the air filter.

Type2

- 1 Turn off the power to the unit.
- 2 Open the front cover.
 - Lift up both sides of the cover slightly.
- 3 Hold the knobs of the air filters, pull them down slightly and remove them from the indoor unit.

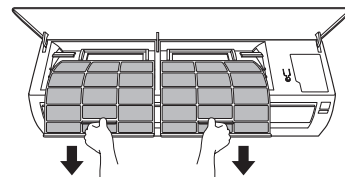

- 4 Clean the filters with a vacuum cleaner or with lukewarm water with neutral detergent.
- 5 Dry the filters in the shade.
- 6 Insert the hooks of the air filters into the front cover.

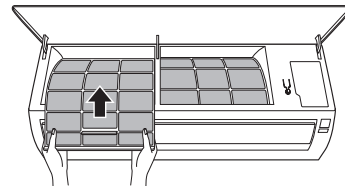

- 7 Check the side of the front cover for correct assembly of the air filters.

Clean the 3M and Triple Filter (Optional)

- 1 Turn off the power to the unit.
- 2 Remove the air filters from the indoor unit.
- 3 Remove the 3M and Triple filter from the indoor unit.

Type1

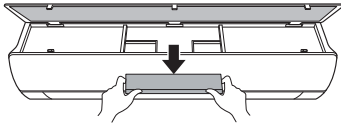

Type2

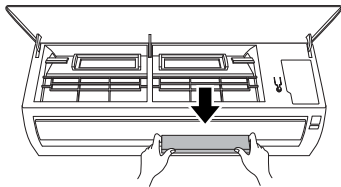

- 4 Clean the filter with a vacuum cleaner.

- 5 Insert the 3M and Triple filter.

Type1

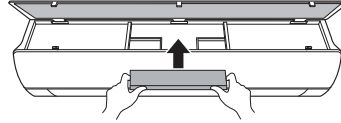

Type2

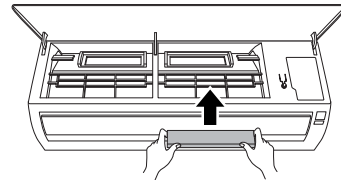

- 6 Assemble the air filters.
- 7 Check the side of the front cover for correct assembly of the air filters.

NOTE

- The feature and location of 3M and Triple filter may vary according to the type of model.

TROUBLESHOOTING

Self-diagnosis Function

This product has a built-in self-diagnosis function. If an error occurs, the lamp of the indoor unit will blink in 2 second intervals. If this occurs, contact your local dealer or service center.

Before Calling for Service

Please check the following before you contact the service center. If the problem persists, contact your local service center.

Problem	Possible Causes	Corrective Action
The air conditioner does not work normally.	Burning smell and strange sounds are coming from the unit.	<ul style="list-style-type: none"> • Turn off the air conditioner, switch OFF, or disconnect the power supply, and contact the service center.
	Water leaks from the indoor unit even when the humidity level is low.	
	The power cable is damaged or it is generating excessive heat.	
	A switch, a circuit breaker (safety, ground), or a fuse is not operated properly.	
	The unit generates an error code from its self-diagnosis.	
The air conditioner does not work.	The air conditioner is unplugged.	<ul style="list-style-type: none"> • Check whether the power cord is plugged into the outlet or the power isolators are switched on.
	A fuse exploded, or the power supply is blocked.	<ul style="list-style-type: none"> • Replace the fuse or check if the circuit breaker has tripped.
	A power failure has occurred.	<ul style="list-style-type: none"> • Turn off the air conditioner when a power failure occurs. • When the power is restored, wait 3 minutes, and then turn on the air conditioner.
	The voltage is too high or too low.	<ul style="list-style-type: none"> • Check if the circuit breaker has tripped.
	The air conditioner was turned off automatically at a preset time.	<ul style="list-style-type: none"> • Turn the air conditioner on.
	The battery setting in the remote controller is incorrect.	<ul style="list-style-type: none"> • Make sure that the batteries are inserted correctly in your remote controller. • If the batteries are placed correctly, but the air conditioner still does not operate, replace the batteries and try again.

Problem	Possible Causes	Corrective Action
The air conditioner does not emit cool air.	Air is not circulating properly.	<ul style="list-style-type: none"> • Make sure that there are no curtains, blinds, or pieces of furniture blocking the front of the air conditioner.
	The air filter is dirty.	<ul style="list-style-type: none"> • Clean the air filter once every 2 weeks. • See “Clean the Air Filter” for more information.
	The room temperature is too high.	<ul style="list-style-type: none"> • In summer, cooling the indoor air fully may take some time. In this case, select the Jet Mode to cool the indoor air quickly.
	Cold air is escaping from the room.	<ul style="list-style-type: none"> • Make sure that no cold air is escaping through the ventilation points in the room.
	The desired temperature is higher than the current temperature.	<ul style="list-style-type: none"> • Set the desired temperature to a level lower than the current temperature.
	There is a heating source nearby.	<ul style="list-style-type: none"> • Avoid using heat generators like electric ovens or gas burners while the air conditioner is in operation.
	Fan Mode is selected.	<ul style="list-style-type: none"> • During Fan Mode, air blows from the air conditioner without cooling or heating the indoor air. • Switch the operation mode to cooling operation.
	Outside temperature is too high.	<ul style="list-style-type: none"> • The cooling effect may not be sufficient.
The fan speed cannot be adjusted.	The Jet Mode, or Auto Operation Mode is selected.	<ul style="list-style-type: none"> • In some operation modes, you cannot adjust the fan speed. Select an operation mode in which you can adjust the fan speed.
The temperature cannot be adjusted.	The Fan Mode or Jet Mode is selected.	<ul style="list-style-type: none"> • In some operation modes, you cannot adjust the temperature. Select an operation mode in which you can adjust the temperature.
The air conditioner stops during operation.	The air conditioner is suddenly turned off.	<ul style="list-style-type: none"> • The Timer Function may have timed out, which turns the unit off. Check the timer settings.
	A power failure has occurred during operation.	<ul style="list-style-type: none"> • Wait for the power to come back. If you have the Auto Restart function enabled, your unit will resume its last operation several minutes after power is restored.

Problem	Possible Causes	Corrective Action
The indoor unit is still operating even when the unit has been turned off.	The Auto Clean function is being operated.	<ul style="list-style-type: none"> Allow the Auto Clean function to continue since it removes any remaining moisture inside the indoor unit. If you do not want this feature, you can turn the unit off.
The air outlet on the indoor unit is discharging mist.	The cooled air from the air conditioner makes mist.	<ul style="list-style-type: none"> When the room temperature decreases, this phenomenon will disappear.
Water leaks from the outdoor unit.	In the heating operations, condensed water drops from the heat exchanger.	<ul style="list-style-type: none"> This symptom requires installing a drain hose under the base pan. Contact the installer.
There is noise or vibration.	<p>A clicking sound can be heard when the unit starts or stops due to movement of the reversing valve.</p> <p>Creaking sound: The plastic parts of the indoor unit creak when they shrink or expand due to sudden temperature changes.</p> <p>Flowing or Blowing sound: This is the flow of refrigerant through the air conditioner.</p>	<ul style="list-style-type: none"> These are normal symptoms. The noise will stop.
The indoor unit gives off an odor.	Odors (such as cigarette smoke) may be absorbed into the indoor unit and discharged with airflow.	<ul style="list-style-type: none"> If the smell does not disappear, you need to wash the filter. If this does not work, contact the service center to clean your heat exchanger.
The air conditioner does not emit warm air.	When Heating Mode starts, the vane is almost closed, and no air comes out, even though the outdoor unit is operating.	<ul style="list-style-type: none"> This symptom is normal. Please wait until the unit has generated enough warm air to blow through the indoor unit.
	The outdoor unit is in Defrosting Mode.	<ul style="list-style-type: none"> In Heating Mode, ice/frost is built up on the coils when the outside temperature falls. This function removes a layer of frost on the coil, and it should finish in approximately 15 minutes.
	Outside temperature is too low.	<ul style="list-style-type: none"> The heating effect may not be sufficient.

Problem	Possible Causes	Corrective Action
Your home appliance and smartphone is not connected to the Wi-Fi network.	The password for the Wi-Fi that you are trying to connect to is incorrect.	<ul style="list-style-type: none"> Find the Wi-Fi network connected to your smartphone and remove it, then register your appliance on LG SmartThinQ.
	Mobile data for your smartphone is turned on.	<ul style="list-style-type: none"> Turn off the Mobile data of your smartphone and register the appliance using the Wi-Fi network.
	The wireless network name (SSID) is set incorrectly.	<ul style="list-style-type: none"> The wireless network name (SSID) should be a combination of English letters and numbers. (Do not use special characters.)
	The router frequency is not 2.4 GHz.	<ul style="list-style-type: none"> Only a 2.4 GHz router frequency is supported. Set the wireless router to 2.4 GHz and connect the appliance to the wireless router. To check the router frequency, check with your Internet service provider or the router manufacturer.
	The distance between the appliance and the router is too far.	<ul style="list-style-type: none"> If the distance between the appliance and the router is too far, the signal may be weak and the connection may not be configured correctly. Move the location of the router so that it is closer to the appliance.

NOTE

- Some functions may not be supported, depending on the model.

WARRANTY (USA)

ARBITRATION NOTICE: THIS LIMITED WARRANTY CONTAINS AN ARBITRATION PROVISION THAT REQUIRES YOU AND LG TO RESOLVE DISPUTES BY BINDING ARBITRATION INSTEAD OF IN COURT, UNLESS YOU CHOOSE TO OPT OUT. IN ARBITRATION, CLASS ACTIONS AND JURY TRIALS ARE NOT PERMITTED. PLEASE SEE THE SECTION TITLED "PROCEDURE FOR RESOLVING DISPUTES" BELOW.

PROCEDURE FOR RESOLVING DISPUTES:

ALL DISPUTES BETWEEN YOU AND LG ARISING OUT OF OR RELATING IN ANY WAY TO THIS LIMITED WARRANTY OR THE PRODUCT SHALL BE RESOLVED EXCLUSIVELY THROUGH BINDING ARBITRATION, AND NOT IN A COURT OF GENERAL JURISDICTION. BINDING ARBITRATION MEANS THAT YOU AND LG ARE EACH WAIVING THE RIGHT TO A JURY TRIAL AND TO BRING OR PARTICIPATE IN A CLASS ACTION.

Definitions. For the purposes of this section, references to "LG" mean LG Electronics U.S.A., Inc., its parents, subsidiaries and affiliates, and each of their officers, directors, employees, agents, beneficiaries, predecessors in interest, successors, assigns and suppliers; references to "dispute" or "claim" shall include any dispute, claim or controversy of any kind whatsoever (whether based in contract, tort, statute, regulation, ordinance, fraud, misrepresentation or any other legal or equitable theory) arising out of or relating in any way to the sale, condition or performance of the product or this Limited Warranty.

Notice of Dispute. In the event you intend to commence an arbitration proceeding, you must first notify LG in writing at least 30 days in advance of initiating the arbitration by sending a letter to LG at LG Electronics, USA, Inc. Attn: Legal Department- Arbitration 1000 Sylvan Ave, Englewood Cliffs 07632. You and LG agree to engage in good faith discussions in an attempt to amicably resolve your claim. The notice must provide your name, address, and telephone number; identify the product that is the subject of the claim; and describe the nature of the claim and the relief being sought. If you and LG are unable to resolve the dispute within 30 days, either party may proceed to file a claim for arbitration.

Agreement to Binding Arbitration and Class Action Waiver. Upon failure to resolve the dispute during the 30 day period after sending written notice to LG, you and LG agree to resolve any claims between us only by binding arbitration on an individual basis, unless you opt out as provided below. Any dispute between you and LG shall not be combined or consolidated with a dispute involving any other person's or entity's product or claim. More specifically, without limitation of the foregoing, any dispute between you and LG shall not under any circumstances proceed as part of a class or representative action. Instead of arbitration, either party may bring an individual action in small claims court, but that small claims court action may not be brought on a class or representative basis.

Arbitration Rules and Procedures. To begin arbitration of a claim, either you or LG must make a written demand for arbitration. The arbitration will be administered by the American Arbitration Association ("AAA") and will be conducted before a single arbitrator under the AAA's Consumer Arbitration Rules that are in effect at the time the arbitration is initiated (referred to as the "AAA Rules") and under the procedures set forth in this section. The AAA Rules are available online at www.adr.org/consumer. Send a copy of your written demand for arbitration, as well as a copy of this provision, to the AAA in the manner described in the AAA Rules. You must also send a copy of your written demand to LG at LG Electronics, USA, Inc. Attn: Legal Department- Arbitration 1000 Sylvan Avenue Englewood Cliffs, NJ 07632. If there is a conflict between the AAA Rules and the rules set forth in this section, the rules set forth in this section will govern. This arbitration provision is governed by the Federal Arbitration Act. Judgment may be entered on the arbitrator's award in any court of competent jurisdiction. All issues are for the arbitrator to decide, except that issues relating to the scope and enforceability of the arbitration provision and to the arbitrability of the dispute are for the court to decide. The arbitrator is bound by the terms of this provision.

Governing Law. The law of the state of your residence shall govern this Limited Warranty and any disputes between us except to the extent that such law is preempted by or inconsistent with applicable federal law.

Fees/Costs. You do not need to pay any fee to begin an arbitration. Upon receipt of your written demand for arbitration, LG will promptly pay all arbitration filing fees to the AAA unless you seek more than \$25,000 in damages, in which case the payment of these fees will be governed by the AAA Rules. Except as otherwise provided for herein, LG will pay all AAA filing, administration and arbitrator fees for any arbitration initiated in accordance with the AAA Rules and this arbitration provision. If you prevail in the arbitration, LG will pay your attorneys' fees and expenses as long as they are reasonable, by considering factors including, but not limited to, the purchase amount and claim amount. Notwithstanding the foregoing, if applicable law allows for an award of reasonable attorneys' fees and expenses, an arbitrator can award them to the same extent that a court would. If the arbitrator finds either the substance of your claim or the relief sought in the demand is frivolous or brought for an improper purpose (as measured by the standards set forth in Federal Rule of Civil Procedure 11(b)), then the payment of all arbitration fees will be governed by the AAA Rules. In such a situation, you agree to reimburse LG for all monies previously disbursed by it that are otherwise your obligation to pay under the AAA Rules. Except as otherwise provided for, LG waives any rights it may have to seek attorneys' fees and expenses from you if LG prevails in the arbitration.

Hearings and Location. If your claim is for \$25,000 or less, you may choose to have the arbitration conducted solely on the basis of (1) documents submitted to the arbitrator, (2) through a telephonic hearing, or (3) by an in-person hearing as established by the AAA Rules. If your claim exceeds \$25,000, the right to a hearing will be determined by the AAA Rules. Any in-person arbitration hearings will be held at a location within the federal judicial district in which you reside unless we both agree to another location or we agree to a telephonic arbitration.

Opt Out. You may opt out of this dispute resolution procedure. If you opt out, neither you nor LG can require the other to participate in an arbitration proceeding. To opt out, you must send notice to LG no later than 30 calendar days from the date of the first consumer purchaser's purchase of the product by either: (i) sending an e-mail to optout@lge.com, with the subject line: "Arbitration Opt Out" or (ii) calling 1-800-980-2973. You must include in the opt out e-mail or provide by telephone: (a) your name and address; (b) the date on which the product was purchased; (c) the product model name or model number; and (d) the serial number (the serial number can be found (i) on the product; or (ii) online by accessing <https://www.lg.com/us/support/repair-service/schedule-repair-continued> and clicking on "Find My Model & Serial Number").

You may only opt out of the dispute resolution procedure in the manner described above (that is, by e-mail or telephone); no other form of notice will be effective to opt out of this dispute resolution procedure. Opting out of this dispute resolution procedure will not affect the coverage of the Limited Warranty in any way, and you will continue to enjoy the full benefits of the Limited Warranty. If you keep this product and do not opt out, then you accept all terms and conditions of the arbitration provision described above.

WARRANTY (CANADA)

ARBITRATION NOTICE: THIS LIMITED WARRANTY CONTAINS AN ARBITRATION PROVISION THAT REQUIRES YOU AND LG TO RESOLVE DISPUTES BY BINDING ARBITRATION INSTEAD OF IN COURT, UNLESS THE LAWS OF YOUR PROVINCE OR TERRITORY DO NOT PERMIT THAT, OR, IN OTHER JURISDICTIONS, IF YOU CHOOSE TO OPT OUT. IN ARBITRATION, CLASS ACTIONS AND JURY TRIALS ARE NOT PERMITTED. PLEASE SEE THE SECTION TITLED "PROCEDURE FOR RESOLVING DISPUTES" BELOW.

PROCEDURE FOR RESOLVING DISPUTES:

EXCEPT WHERE PROHIBITED AT LAW, ALL DISPUTES BETWEEN YOU AND LG ARISING OUT OF OR RELATING IN ANY WAY TO THIS LIMITED WARRANTY OR THE PRODUCT SHALL BE RESOLVED EXCLUSIVELY THROUGH BINDING ARBITRATION, AND NOT IN A COURT OF GENERAL JURISDICTION. EXCEPT WHERE PROHIBITED AT LAW, YOU AND LG BOTH IRREVOCABLY AGREE TO WAIVE THE RIGHT TO A JURY TRIAL AND TO BRING OR PARTICIPATE IN A CLASS ACTION.

Definitions. For the purposes of this section, references to "LG" mean LG Electronics Canada, Inc., its parents, subsidiaries and affiliates, and each of their officers, directors, employees, agents, beneficiaries, predecessors in interest, successors, assigns and suppliers; references to "dispute" or "claim" shall include any dispute, claim or controversy of any kind whatsoever (whether based in contract, tort, statute, regulation, ordinance, fraud, misrepresentation or any other legal or equitable theory) arising out of or relating in any way to the sale, condition or performance of the product or this Limited Warranty.

Notice of Dispute. In the event you intend to commence an arbitration proceeding, you must first notify LG in writing at least 30 days in advance of initiating the arbitration by sending a letter to LGECI Legal Team at 20 Norelco Drive, North York, Ontario, Canada M9L 2X6 (the "Notice of Dispute"). You and LG agree to engage in good faith discussions in an attempt to amicably resolve your claim. The notice must provide your name, address, and telephone number; identify the product that is the subject of the claim; and describe the nature of the claim and the relief being sought. If you and LG are unable to resolve the dispute within 30 days of LG's receipt of the Notice of Dispute, the dispute shall be resolved by binding arbitration in accordance with the procedure set out herein. You and LG both agree that, during the arbitration proceeding, the terms (including any amount) of any settlement offer made by either you or LG will not be disclosed to the arbitrator until the arbitrator determines the dispute.

Agreement to Binding Arbitration and Class Action Waiver. Upon failure to resolve the dispute during the 30 day period after LG's receipt of the Notice of Dispute, you and LG agree to resolve any claims between you and LG only by binding arbitration on an individual basis, unless you opt out as provided below, or you reside in a jurisdiction that prevents full application of this clause in the circumstances of the claims at issue (in which case if you are a consumer, this clause will only apply if you expressly agree to the arbitration). To the extent permitted by applicable law, any dispute between you and LG shall not be combined or consolidated with a dispute involving any other person's or entity's product or claim. More specifically, without limitation of the foregoing, except to the extent such a prohibition is not permitted at law, any dispute between you and LG shall not under any circumstances proceed as part of a class or representative action. Instead of arbitration, either party may bring an individual action in small claims court, but that small claims court action may not be brought on a class or representative basis except to the extent this prohibition is not permitted at law in your province or territory of jurisdiction as it relates to the claims at issue between you and LG.

Arbitration Rules and Procedures. To begin arbitration of a claim, either you or LG must make a written demand for arbitration. The arbitration will be private and confidential, and conducted on a simplified and expedited basis before a single arbitrator chosen by the parties under the provincial or territorial commercial arbitration law and rules of the province or territory of your residence. You must also send a copy of your written demand to LG at LG Electronics, Canada, Inc., Attn: Legal Department- Arbitration, 20 Norelco Drive, North York, Ontario M9L 2X6. This arbitration provision is governed by your applicable provincial or territorial commercial arbitration legislation. Judgment may be entered on the arbitrator's award in any court of competent jurisdiction. All issues are for the arbitrator to decide, except that, issues relating to the scope and enforceability of the arbitration provision and to the arbitrability of the dispute are for the court to decide. The arbitrator is bound by the terms of this provision.

Governing Law. The law of the province or territory of your purchase shall govern this Limited Warranty and any disputes between you and LG except to the extent that such law is preempted by or inconsistent with applicable federal or provincial/territorial law. Should arbitration not be permitted for any claim, action, dispute or controversy between you and LG, you and LG attorn to the exclusive jurisdiction of the courts of the province or territory of your purchase for the resolution of the claim, action, dispute or controversy between you and LG.

Fees/Costs. You do not need to pay any fee to begin an arbitration. Upon receipt of your written demand for arbitration, LG will promptly pay all arbitration filing fees unless you seek more than \$25,000 in damages, in which case the payment of these fees will be governed by the applicable arbitration rules. Except as otherwise provided for herein, LG will pay all filing, administration and arbitrator fees for any arbitration initiated in accordance with the applicable arbitration rules and this arbitration provision. If you prevail in the arbitration, LG will pay your attorneys' fees and expenses as long as they are reasonable, by considering factors including, but not limited to, the purchase amount and claim amount. Notwithstanding the foregoing, if applicable law allows for an award of reasonable attorneys' fees and expenses, an arbitrator can award them to the same extent that a court would. If the arbitrator finds either the substance of your claim or the relief sought in the demand is frivolous or brought for an improper purpose (as measured by the applicable laws), then the payment of all arbitration fees will be governed by the applicable arbitration rules. In such a situation, you agree to reimburse LG for all monies previously disbursed by it that are otherwise your obligation to pay under the applicable arbitration rules. Except as otherwise provided for, LG waives any rights it may have to seek attorneys' fees and expenses from you if LG prevails in the arbitration.

Hearings and Location. If your claim is for \$25,000 or less, you may choose to have the arbitration conducted solely (1) on the basis of documents submitted to the arbitrator, (2) through a telephonic hearing, or (3) by an in-person hearing as established by the applicable arbitration rules. If your claim exceeds \$25,000, the right to a hearing will be determined by the applicable arbitration rules. Any in-person arbitration hearings will be held at the nearest, most mutually-convenient arbitration location available within the province or territory in which you reside unless you and LG both agree to another location or agree to a telephonic arbitration.

Severability and Waiver. If any portion of this Limited Warranty (including these arbitration procedures) is unenforceable, the remaining provisions will continue in full force and effect to the maximum extent permitted by applicable law. Should LG fail to enforce strict performance of any provision of this Limited Warranty (including these arbitration procedures), it does not mean that LG intends to waive or has waived any provision or part of this Limited Warranty.

Opt Out. You may opt out of this dispute resolution procedure. If you opt out, neither you nor LG can require the other to participate in an arbitration proceeding. To opt out, you must send notice to LG no later than 30 calendar days from the date of the first consumer purchaser's purchase of the product by either (i) sending an e-mail to optout@lge.com, with the subject line: "Arbitration Opt Out;" or (ii) calling 1-800-980-2973. You must include in the opt out e-mail or provide by telephone: (a) your name and address; (b) the date on which the product was purchased; (c) the product model name or model number; and (d) the serial number (the serial number can be found (i) on the product; or (ii) online by accessing https://www.lg.com/ca_en/support/repair-service/schedule-repair and clicking on "Find My Model & Serial Number").

In the event that you "Opt Out", the law of the province or territory of your residence shall govern this Limited Warranty and any disputes between you and LG except to the extent that such law is preempted by or inconsistent with applicable federal or provincial/territorial law. Should arbitration not be permitted for any claim, action, dispute or controversy between you and LG, you and LG agree to attorn to the exclusive jurisdiction of the courts of the province or territory of your residence for the resolution of the claim, action, dispute or controversy between you and LG.

You may only opt out of the dispute resolution procedure in the manner described above (that is, by e-mail or telephone); no other form of notice will be effective to opt out of this dispute resolution procedure. Opting out of this dispute resolution procedure will not affect the coverage of the Limited Warranty in any way, and you will continue to enjoy the full benefits of the Limited Warranty. If you keep this product and do not opt out, then you accept all terms and conditions of the arbitration provision described above.

Conflict of Terms. In the event of a conflict or inconsistency between the terms of this Limited Warranty and the End User License Agreement ("EULA") in regards to dispute resolution, the terms of this Limited Warranty shall control and govern the rights and obligations of the parties and shall take precedence over the EULA.



US	Please call the installing contractor of your product, as warranty service will be provided by them.
CANADA	Service call Number # : (888) LG Canada, (888) 542-2623 Numéro pour les appels de service : LG Canada, 1-888-542-2623