



Quality People. Building Solutions.

Comfort Systems USA (Arkansas), Inc.
P.O. Box 16620
LittleRock, AR 72231
Phone 501-834-3320
Fax 501-834-5416

Date: 4/23/2026

Return Request: 4/30/2026

Project: Hot Springs National Park – Rehabilitate Bathhouses – Maurice Bathhouse

Supplier: Custom Sheet Metal

Manufacturer: Titus

Submittal: Terminal Heat Transfer Units (Terminal Air Boxes)(TAB Units)(Re-Submittal #1)

Submittal Number: 238200.005

Spec Section: 238200, 2.5

Drawing # and Installation Location: MP1.1, MP1.2, and MP4.0

ARCHITECT

Strata Architecture
1701 Oak Street, Suite 100
Kansas City, Missouri 64108
(816)474-0900

GENERAL CONTRACTOR

Tepa, LLC
2345 Grand Blvd, Suite 700
Kansas City, Missouri 64108
(816)708-1110

ENGINEER

IMEG Corp.
1600 Baltimore Street, Suite 300
Kansas City, Missouri 64108
(816)842-8437

MECHANICAL SUBCONTRACTOR

Comfort Systems USA (Arkansas), Inc.
9924 Landers Road
North Little Rock, Arkansas 72117
(501)834-3320

Comments:

CSUSA PROJECT NO.

25-7065

joe@comfortar.com

9924 Landers Road
No. LittleRock, AR 72117



Job: **Maurice Bathhouse Renovations**

Spec: **Air Terminal Units**

Item: **VAV Boxes**

Submitted by:

Joe Minton Jr.

Vice President HVAC

(501) 607-0043



RE-SUBMITTAL

PRODUCT	VAV Terminal Boxes
MANUFACTURER	Titus HVAC
JOB NAME	Maurice Bathhouse Renovation
LOCATION	Hot Springs, AR
ENGINEER	IMEG Consultants Corp
CONTRACTOR	Custom Sheet Metal
DATE	4/23/2026
SUBMITTED BY	Courtney Michael

Single Duct Terminal Unit Schedule

Tag	Model	Size		CFM		Static Pressure			NC Levels		Hot Water Heat Coil										Unit Information	
		Unit	Outlet	Max	Min	Inlet	Down	Min	Rad	Dis	CFM	MBH	EAT	EWT	LAT	APd	GPM	LWT	WPd	Rows	FPI	Hand
TAB-1-10M	DESV	09	14x12.5	870	175	1	0.25	0.53	17	24	870	32.3	55	140	89.3	0.48	2.1	108.7	0.21	4-RH	10	RH
TAB-1-11M	DESV	06	12x8	460	95	1	0.25	0.41	18	25	95	3.7	55	140	90.5	0.24	0.3	115.2	0.02	2-RH	10	RH
TAB-1-12M	DESV	12	16x15	1480	300	1	0.25	0.7	19	25	590	33.4	55	140	107.2	0.69	2.2	109.1	0.25	4-RH	10	RH
TAB-1-1M	DESV	09	14x12.5	870	175	1	0.25	0.53	17	24	800	30.8	55	140	90.4	0.48	2	108.7	0.19	4-RH	10	RH
TAB-1-2M	DESV	04	12x8	120	40	1	0.25	0.06	10	29	115	4.4	55	140	90.6	0.03	0.5	122	0.06	2-RH	10	RH
TAB-1-3M	DESV	12	16x15	1480	300	1	0.25	0.7	19	25	590	33.4	55	140	107.2	0.69	2.2	109.1	0.25	4-RH	10	RH
TAB-1-4M	DESV	07	12x10	520	105	1	0.25	0.47	19	24	520	19	55	140	88.7	0.38	1.3	110.3	0.13	4-RH	10	RH
TAB-1-5M	DESV	12	16x15	1260	255	1	0.25	0.41	18	24	1260	43.2	55	140	86.6	0.4	2.8	108.6	0.48	3-RH	10	RH
TAB-1-6M	DESV	14	20x17.5	1650	330	1	0.25	0.35	15	19	1650	59.7	55	140	88.4	0.33	3.6	106.2	0.48	3-RH	10	RH
TAB-1-7M	DESV	12	16x15	1365	275	1	0.25	0.46	18	25	1365	45.3	55	140	85.6	0.45	3	109.3	0.5	3-RH	10	RH
TAB-1-8M	DESV	12	16x15	630	190	1	0.25	0.11	13	23	630	21.3	55	140	86.1	0.1	1.4	109.1	0.25	2-RH	12	RH
TAB-1-9M	DESV	08	12x10	610	125	1	0.25	0.52	18	27	610	19.9	55	140	85.1	0.5	1.3	109.1	0.13	4-RH	10	RH
TAB-2-1M	DESV	8E	14x12.5	760	140	1	0.25	0.41	20	25	450	26	55	140	108.3	0.39	2.2	115.9	0.22	4-RH	10	RH
TAB-2-2M	DESV	8E	14x12.5	770	155	1	0.25	0.42	20	27	770	35.5	55	140	97.5	0.39	2.8	114.2	0.31	4-RH	10	RH
TAB-2-3M	DESV	7E	14x12.5	375	75	1	0.25	0.17	17	23	340	20.7	55	140	111.1	0.12	1.7	115.2	0.15	4-RH	10	RH
TAB-2-4M	DESV	8E	14x12.5	760	155	1	0.25	0.41	20	25	455	26.2	55	140	108	0.39	2.2	115.8	0.22	4-RH	10	RH
TAB-2-5M	DESV	07	12x10	440	90	1	0.25	0.29	18	24	440	14.6	55	140	85.5	0.22	1	110.4	0.13	3-RH	10	RH
TAB-2-6M	DESV	8E	14x12.5	800	160	1	0.25	0.45	22	27	800	36	55	140	96.4	0.42	2.8	113.9	0.31	4-RH	10	RH

- No 1. Selections are based on Titus as Manufacturer.
2. All performance based on tests conducted in accordance with ASHRAE 130-2008 and AHRI 880-2011.
3. All NC levels determined using AHRI 885-2008 Appendix E.
4. All airflow, pressure losses and heating performance values have been corrected for altitude.
5. Units of measure: dimensions (in), airflow (cfm), water flow (gpm), air pressure (in wg), water head losses (ft) and
6. Water pressure drop (WPd) units is in ft. water.

Re-Submittal Notes

- In some cases, simply moving from a 3 row coil to a 4 row coil was enough to raise the LAT and lower the LWT closer to 110.
- For TAB-2-1M, TAB-2-2M, TAB-2-3M, TAB-2-4M and TAB-2-6M it was also necessary to raise the GPMs up above the scheduled "max gpm". Based on the scheduled performance of the boxes, this is all that could be done to raise the leaving air temperatures. All leaving water temperatures are as close to 110 as possible-
- In reference to the engineers comment of a 6" inlet size being scheduled for TAB-1-4M, it was changed to a 7" box because 520 cfm's is out of the primary air range of a 6" Titus VAV box.
- In reference to the engineers comment of 130 cfms scheduled for the minimum cfm of TAB-1-8M, 190 was used because it is the lowest minimum cfm allowed for a 12" Titus VAV box.
- For TAB-1-11M, it was necessary to change the box to a 2 row coil and "lower" the scheduled GPM to meet the minimum LAT and lower the LWT.

The results of this program are only an aid to the designer, and are not a substitute for professional design services.

Titus accepts no liability for the adequacy of any resulting design or installation.

DESV

Single Duct Terminal Unit, Direct Digital Control, Pressure Independent

Main Product **DESV-1**

DESV

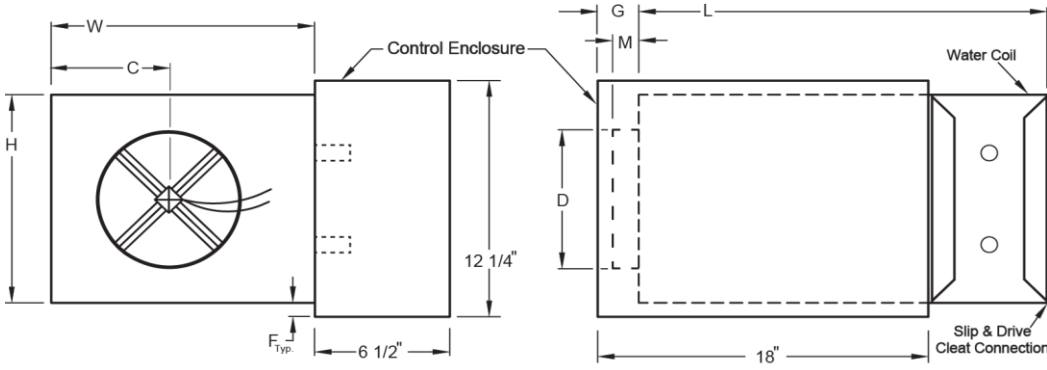

Right Hand Unit with Right Hand HWC Connections shown

Air Inlet (D) is 1/8" smaller than its Nom. Inlet.
 All dimensions are in inches.

Unit-Size	CFM Range	Nom. Inlet	F	C	W	H	M	G	L
09	0 - 1050	9" Dia.	-	22 3/4"	14"	12 1/2"	3 3/8"	7"	5 3/8"
12	0 - 2000	12" Dia.	-	22 3/4"	16"	15"	3 3/8"	8"	5 3/8"
07	0 - 650	7" Dia.	1 1/8"	22 3/4"	12"	10"	3 3/8"	6"	7 3/8"
14	0 - 3000	14" Dia.	-	25 1/4"	20"	17 1/2"	3 3/8"	10 1/2"	3 3/8"
08	0 - 900	8" Dia.	1 1/8"	22 3/4"	12"	10"	3 3/8"	6"	7 3/8"
8E	0 - 900	8" Dia.	1 1/8"	22 3/4"	14"	12 1/2"	3 3/8"	7"	7 3/8"
7E	0 - 650	7" Dia.	1 1/8"	22 3/4"	14"	12 1/2"	3 3/8"	7"	7 3/8"

General Description **DESV-1**

- Standard construction uses G40 22-gauge galvanized steel housing, and optional construction uses G40 20-gauge galvanized steel housing.
- Mechanically sealed and gasketed, leak resistant construction. Less than 2% of nominal CFM at 1.5" sp wg.
- Dual density internal insulation, treated to resist air erosion. Meets requirements of NFPA 90A and UL 181.
- Rectangular discharge opening is designed for slip and drive cleat duct connection.
- Multipoint center averaging inlet velocity sensor.
- Digital control packages can be factory mounted by Titus.
- Model DESV without coils can be installed horizontally, vertically, or at any angle. Operation is not affected by position. For units with coils, consult technical support.
- Gauge tees for CFM measurement.

Project Rehabilitate Bathhouses - IV
 Architect
 Engineer
 Contractor
 Designation VAV



Date 04/23/2026
 Office Powers of Arkansas
 Preparer Courtney Michael
 Version 2014.0.602

Option Schedule **DESV-1**

ID	Quantity	Tag	UNIT SIZE	MAX PRIMARY CFM	MIN PRIMARY CFM
1	1	TAB-1-1M	09	870	175
3	1	TAB-1-3M	12	1480	300
4	1	TAB-1-4M	07	520	105
9	1	TAB-1-9M	08	610	125
10	1	TAB-1-10M	09	870	175
12	1	TAB-1-12M	12	1480	300
13	1	TAB-2-1M	8E	760	140
14	1	TAB-2-2M	8E	770	155
15	1	TAB-2-3M	7E	375	75
16	1	TAB-2-4M	8E	760	155
18	1	TAB-2-6M	8E	800	160

SENSOR CODE 3 - AEROCROSS	UNIT ACC3 0 -NONE
UNIT CONFIG 0 -BASIC	UNIT ACC4 0 -NONE
LINER OPTION M - 1" EcoShield (Foil Face)	UNIT ACC5 0 -NONE
CASING CONFIG 0R -STD 22GA RH	WATER COIL W14 -4 ROW RH
DIGITAL CONTROLLER 0000 -NONE	ELECTRIC HEAT TYPE 000 -NONE
ACTUATOR TYPE 0000 -NONE	KW 0
CONTROL ACC1 00 -NONE	ELEC COIL ACC1 0 -NONE
CONTROL ACC2 00 -NONE	ELEC COIL ACC2 0 -NONE
CONTROL ACC3 00 -NONE	ELEC COIL ACC3 0 -NONE
UNIT ACC1 E -METAL CTRL ENCLOS	ELEC COIL ACC4 0 -NONE
UNIT ACC2 B -HANGER BRACKET	

ID	Quantity	Tag	UNIT SIZE	MAX PRIMARY CFM	MIN PRIMARY CFM
5	1	TAB-1-5M	12	1260	255
6	1	TAB-1-6M	14	1650	330
7	1	TAB-1-7M	12	1365	275
17	1	TAB-2-5M	07	440	90

SENSOR CODE 3 - AEROCROSS	UNIT ACC3 0 -NONE
UNIT CONFIG 0 -BASIC	UNIT ACC4 0 -NONE
LINER OPTION M - 1" EcoShield (Foil Face)	UNIT ACC5 0 -NONE
CASING CONFIG 0R -STD 22GA RH	WATER COIL W13 -3 ROW RH
DIGITAL CONTROLLER 0000 -NONE	ELECTRIC HEAT TYPE 000 -NONE
ACTUATOR TYPE 0000 -NONE	KW 0
CONTROL ACC1 00 -NONE	ELEC COIL ACC1 0 -NONE
CONTROL ACC2 00 -NONE	ELEC COIL ACC2 0 -NONE
CONTROL ACC3 00 -NONE	ELEC COIL ACC3 0 -NONE
UNIT ACC1 E -METAL CTRL ENCLOS	ELEC COIL ACC4 0 -NONE
UNIT ACC2 B -HANGER BRACKET	

Accessories

DESV-1

ESV Hot Water Reheat: 4-Row, Right Hand for size 09, 10, 7E, & 8E

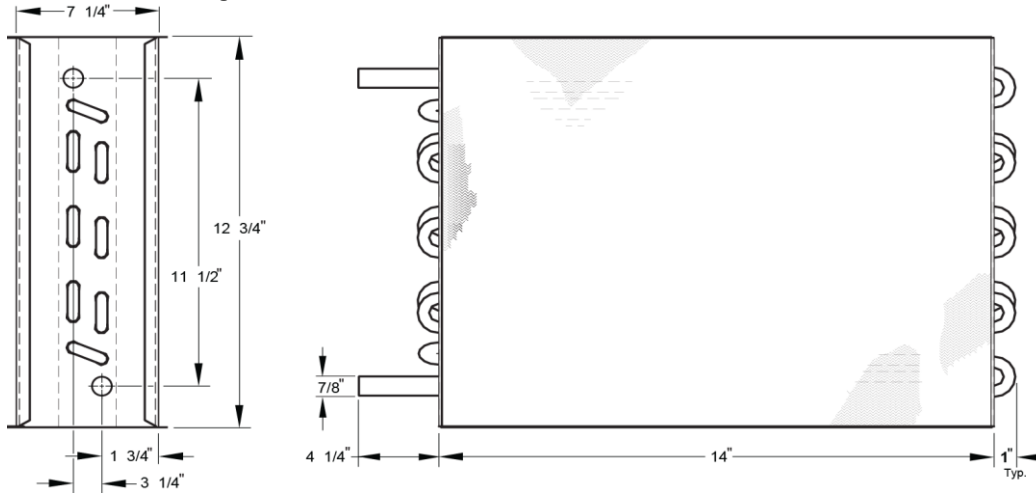

- Coil tubing is 1/2" OD with a 0.016" thick copper wall.
- Coil connection tubing has a 0.032" thick copper wall.
- Aluminum plate fins are 10 per inch.
- Casing is 20 Gauge galvanized steel.
- Copper male solder connections.
- Connection is slip and drive to duct work down stream of terminal.
- Leak tested to 450 PSIG.
- Maximum working pressure, 360 PSIG
- Maximum 200 degree F water
- Coils rated and certified to AHRI Standard 410

Water Weight (lbs.)	Water Voume (gal)
4.62	0.56

ESV Hot Water Reheat: 4-Row, Right Hand for size 12 & 1E

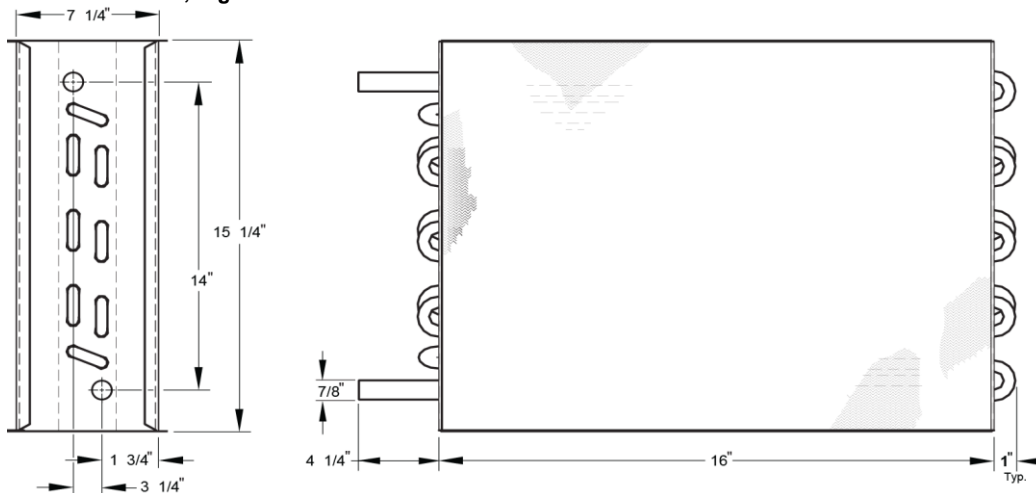

Accessories (continued)

DESV-1

- Coil tubing is 1/2" OD with a 0.016" thick copper wall.
- Coil connection tubing has a 0.032" thick copper wall.
- Aluminum plate fins are 10 per inch.
- Casing is 20 Gauge galvanized steel.
- Copper male solder connections.
- Connection is slip and drive to duct work down stream of terminal.
- Leak tested to 450 PSIG.
- Maximum working pressure, 360 PSIG
- Maximum 200 degree F water
- Coils rated and certified to AHRI Standard 410

Water Weight (lbs.)	water Volume (gal)
6.61	0.79

ESV Hot Water Reheat: 4-Row, Right Hand for size 07, 08, 5E, & 6E

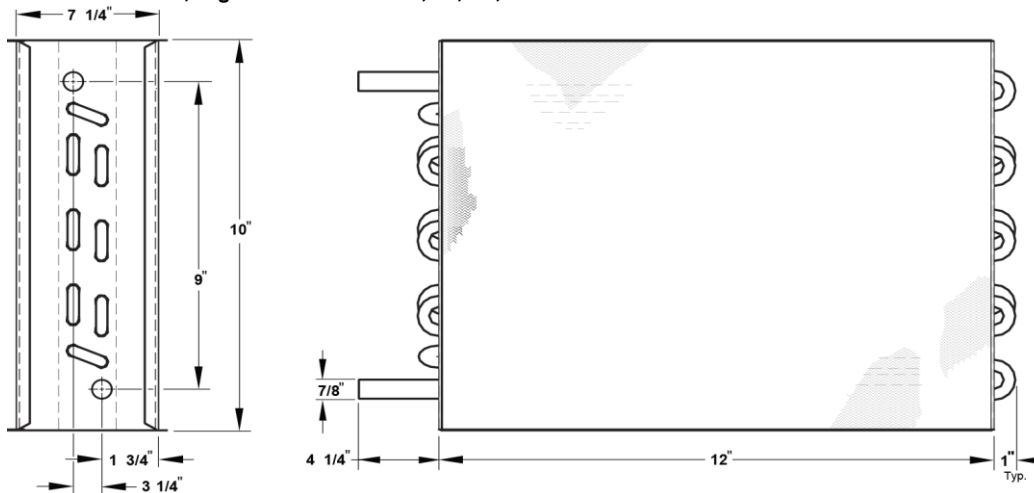

- Coil tubing is 1/2" OD with a 0.016" thick copper wall.
- Coil connection tubing has a 0.032" thick copper wall.
- Aluminum plate fins are 10 per inch.
- Casing is 20 Gauge galvanized steel.
- Copper male solder connections.
- Connection is slip and drive to duct work down stream of terminal.
- Leak tested to 450 PSIG.
- Maximum working pressure, 360 PSIG
- Maximum 200 degree F water
- Coils rated and certified to AHRI Standard 410

Water Weight (lbs.)	Water Volume (gal)
3.92	0.48

Accessories (continued)

DESV-1

ESV Hot Water Reheat: 3-Row, Right Hand for size 12 & 1E

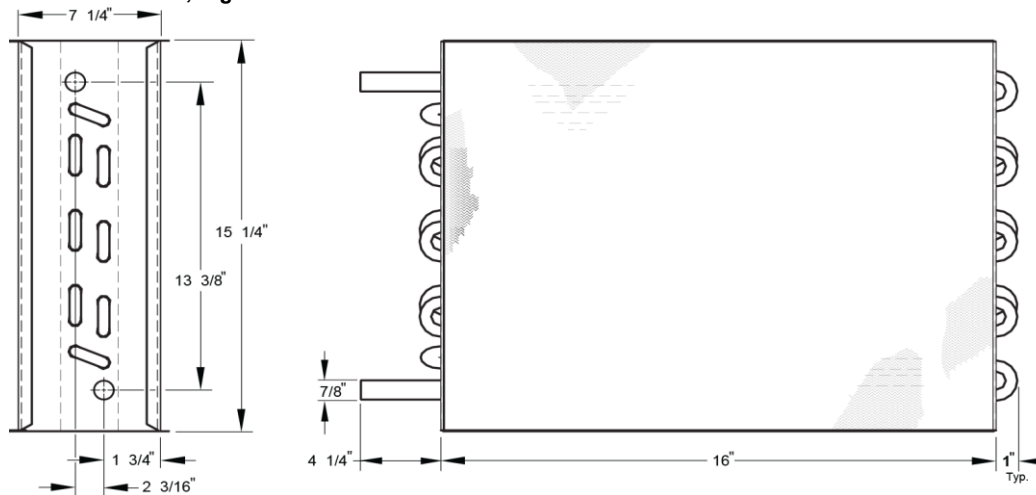

- Coil tubing is 1/2" OD with a 0.016" thick copper wall.
- Coil connection tubing has a 0.032" thick copper wall.
- Aluminum plate fins are 10 per inch.
- Casing is 20 Gauge galvanized steel.
- Copper male solder connections.
- Connection is slip and drive to duct work down stream of terminal.
- Leak tested to 450 PSIG.
- Maximum working pressure, 360 PSIG
- Maximum 200 degree F water
- Coils rated and certified to AHRI Standard 410

Water Weight (lbs.)	water Volume (gal)
5.03	0.6

ESV Hot Water Reheat: 3-Row, Right Hand for size 14 & 2E

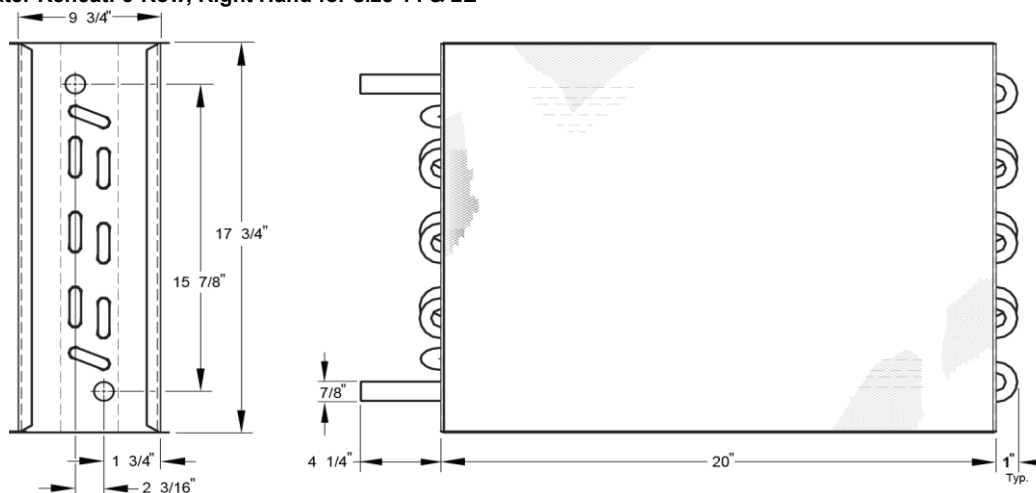

Accessories (continued) DESV-1

- Coil tubing is 1/2" OD with a 0.016" thick copper wall.
- Coil connection tubing has a 0.032" thick copper wall.
- Aluminum plate fins are 10 per inch.
- Casing is 20 Gauge galvanized steel.
- Copper male solder connections.
- Connection is slip and drive to duct work down stream of terminal.
- Leak tested to 450 PSIG.
- Maximum working pressure, 360 PSIG
- Maximum 200 degree F water
- Coils rated and certified to AHRI Standard 410

Water Weight (lbs.)	Water Volume (gal)
5.87	0.71

ESV Hot Water Reheat: 3-Row, Right Hand for size 07, 08, 5E, & 6E

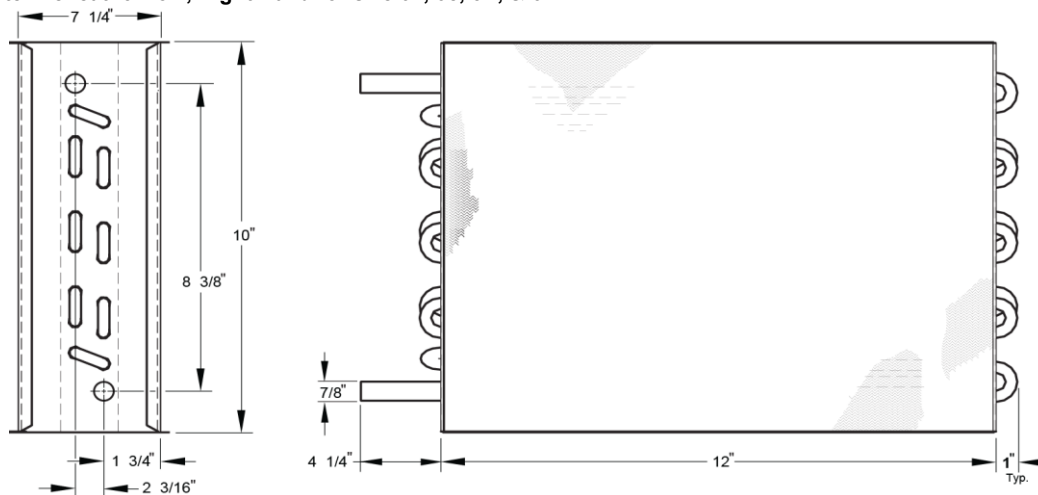

- Coil tubing is 1/2" OD with a 0.016" thick copper wall.
- Coil connection tubing has a 0.032" thick copper wall.
- Aluminum plate fins are 10 per inch.
- Casing is 20 Gauge galvanized steel.
- Copper male solder connections.
- Connection is slip and drive to duct work down stream of terminal.
- Leak tested to 450 PSIG.
- Maximum working pressure, 360 PSIG
- Maximum 200 degree F water
- Coils rated and certified to AHRI Standard 410

Water Weight (lbs.)	Water Volume (gal)
3.92	0.48

DESV

Single Duct Terminal Unit, Direct Digital Control, Pressure Independent

Main Product **DESV-1 (2)**

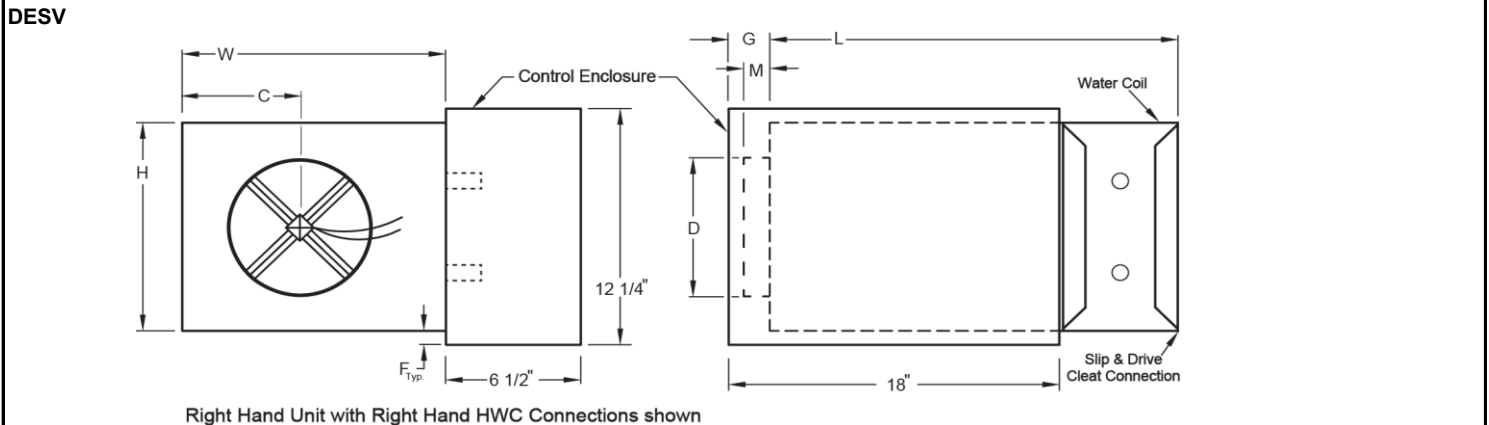

Air Inlet (D) is 1/8" smaller than its Nom. Inlet.
 All dimensions are in inches.

Unit-Size	CFM Range	Nom. Inlet	F	G	W	H	M	L
04	0 - 225	4" Dia.	2 1/8"	7 3/8"	12"	8"	5 3/8"	20 1/2"
12	0 - 2000	12" Dia.	-	5 3/8"	16"	15"	3 3/8"	20 1/2"
06	0 - 500	6" Dia.	2 1/8"	7 3/8"	12"	8"	3 3/8"	20 1/2"

General Description **DESV-1 (2)**

- Standard construction uses G40 22-gauge galvanized steel housing, and optional construction uses G40 20-gauge galvanized steel housing.
- Mechanically sealed and gasketed, leak resistant construction. Less than 2% of nominal CFM at 1.5" sp wg.
- Dual density internal insulation, treated to resist air erosion. Meets requirements of NFPA 90A and UL 181.
- Rectangular discharge opening is designed for slip and drive cleat duct connection.
- Multipoint center averaging inlet velocity sensor.
- Digital control packages can be factory mounted by Titus.
- Model DESV without coils can be installed horizontally, vertically, or at any angle. Operation is not affected by position. For units with coils, consult technical support.
- Gauge tees for CFM measurement.

Option Schedule **DESV-1 (2)**

ID	Quantity	Tag	UNIT SIZE	MAX PRIMARY CFM	MIN PRIMARY CFM
2	1	TAB-1-2M	04	120	40
11	1	TAB-1-11M	06	460	95

Project Rehabilitate Bathhouses - IV
 Architect
 Engineer
 Contractor
 Designation VAV



Date 04/23/2026
 Office Powers of Arkansas
 Preparer Courtney Michael
 Version 2014.0.602

Option Schedule (continued) DESV-1 (2)

<p>SENSOR CODE 3 - AEROCROSS UNIT CONFIG 0 -BASIC LINER OPTION M - 1" EcoShield (Foil Face) CASING CONFIG 0R -STD 22GA RH DIGITAL CONTROLLER 0000 -NONE ACTUATOR TYPE 0000 -NONE CONTROL ACC1 00 -NONE CONTROL ACC2 00 -NONE CONTROL ACC3 00 -NONE UNIT ACC1 E -METAL CTRL ENCLOS UNIT ACC2 B -HANGER BRACKET</p>	<p>UNIT ACC3 0 -NONE UNIT ACC4 0 -NONE UNIT ACC5 0 -NONE WATER COIL W12 -2 ROW RH ELECTRIC HEAT TYPE 000 -NONE KW 0 ELEC COIL ACC1 0 -NONE ELEC COIL ACC2 0 -NONE ELEC COIL ACC3 0 -NONE ELEC COIL ACC4 0 -NONE</p>
--	--

ID	Quantity	Tag	UNIT SIZE	MAX PRIMARY CFM	MIN PRIMARY CFM
8	1	TAB-1-8M	12	630	190

<p>SENSOR CODE 3 - AEROCROSS UNIT CONFIG 0 -BASIC LINER OPTION M - 1" EcoShield (Foil Face) CASING CONFIG 0R -STD 22GA RH DIGITAL CONTROLLER 0000 -NONE ACTUATOR TYPE 0000 -NONE CONTROL ACC1 00 -NONE CONTROL ACC2 00 -NONE CONTROL ACC3 00 -NONE UNIT ACC1 E -METAL CTRL ENCLOS UNIT ACC2 B -HANGER BRACKET</p>	<p>UNIT ACC3 0 -NONE UNIT ACC4 0 -NONE UNIT ACC5 0 -NONE WATER COIL U12 -2 ROW RH HIGH CAPACITY ELECTRIC HEAT TYPE 000 -NONE KW 0 ELEC COIL ACC1 0 -NONE ELEC COIL ACC2 0 -NONE ELEC COIL ACC3 0 -NONE ELEC COIL ACC4 0 -NONE</p>
--	--

Accessories DESV-1 (2)

ESV Hot Water Reheat: 2-Row, Right Hand for size 04, 05, & 06

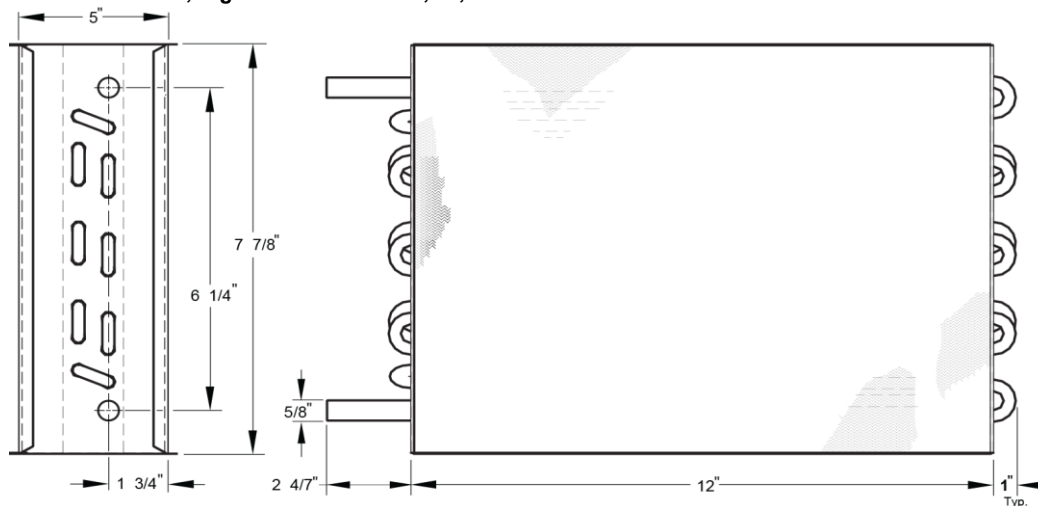

Accessories (continued)

DES-1 (2)

- Coil tubing is 1/2" OD with a 0.016" thick copper wall.
- Coil connection tubing has a 0.032" thick copper wall.
- Aluminum plate fins are 10 per inch.
- Casing is 20 Gauge galvanized steel.
- Copper male solder connections.
- Connection is slip and drive to duct work down stream of terminal.
- Leak tested to 450 PSIG.
- Maximum working pressure, 360 PSIG
- Maximum 200 degree F water
- Coils rated and certified to AHRI Standard 410

Water Weight (lbs.)	Water Volume (gal)
1.26	0.15

ESV Hot Water Reheat: 2-Row, Right Hand for size 12 & 1E

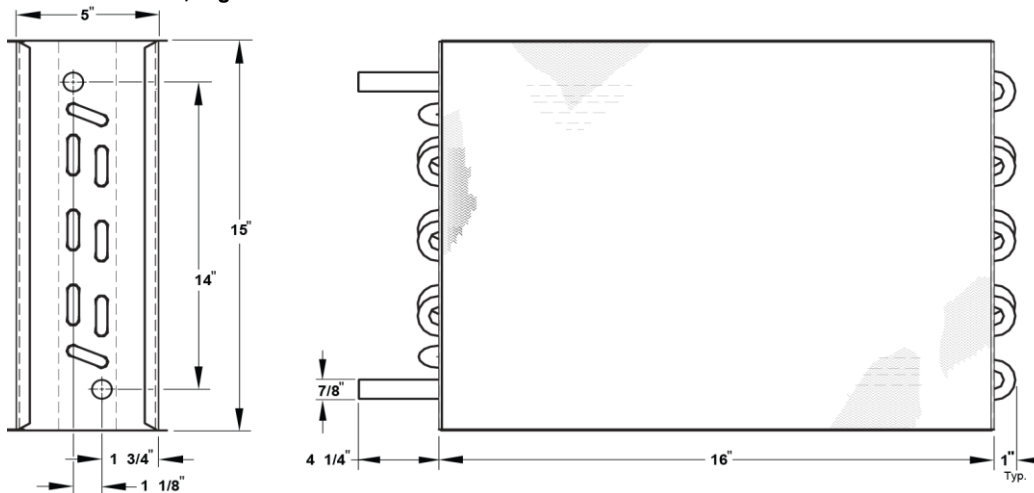

- Coil tubing is 1/2" OD with a 0.016" thick copper wall.
- Coil connection tubing has a 0.032" thick copper wall.
- Aluminum plate fins are 12 per inch.
- Casing is 20 Gauge galvanized steel.
- Copper male solder connections.
- Connection is slip and drive to duct work down stream of terminal.
- Leak tested to 450 PSIG.
- Maximum working pressure is 360 PSIG
- Maximum 200 degree F water