



Quality People. Building Solutions.

Comfort Systems USA (Arkansas), Inc.
P.O. Box 16620
LittleRock, AR 72231
Phone 501-834-3320
Fax 501-834-5416

Date: 4/23/2026

Return Request: 4/30/2026

Project: Hot Springs National Park – Rehabilitate Bathhouses – Maurice Bathhouse

Supplier: Powers of Arkansas

Manufacturer: Vulcan

Submittal: Terminal Heat Transfer Units (HW Unit Heaters (UH-1M and UH-2M)) - (Re-Submittal #1)

Submittal Number: 238200.003

Spec Section: 238200, 2.4

Drawing # and Installation Location: M4.0 and MP1.2

ARCHITECT

Strata Architecture
1701 Oak Street, Suite 100
Kansas City, Missouri 64108
(816)474-0900

GENERAL CONTRACTOR

Tepa, LLC
2345 Grand Blvd, Suite 700
Kansas City, Missouri 64108
(816)708-1110

ENGINEER

IMEG Corp.
1600 Baltimore Street, Suite 300
Kansas City, Missouri 64108
(816)842-8437

MECHANICAL SUBCONTRACTOR

Comfort Systems USA (Arkansas), Inc.
9924 Landers Road
North Little Rock, Arkansas 72117
(501)834-3320

Comments:

CSUSA PROJECT NO.

25-7065

joe@comfortar.com

9924 Landers Road
No. LittleRock, AR 72117



RE-SUBMITTAL

PRODUCT	Terminal Heat Transfer Units
MANUFACTURER	Vulcan
JOB NAME	Maurice Bathhouse Renovation
LOCATION	Hot Springs, AR
ENGINEER	IMEG Consultants Corp
CONTRACTOR	Comfort Systems (USA)
DATE	4/23/2026
SUBMITTED BY	Courtney Michael

5440 Northshore Drive - North Little Rock, Arkansas 72118 - Tel: 501.374.5420 Fax: 501.370.9298

****UH-1M changed to size 62****

Vertical Unit Heaters – Submittal

VVSD-6

Dimensional Data

****Hydronic Unit Heaters****

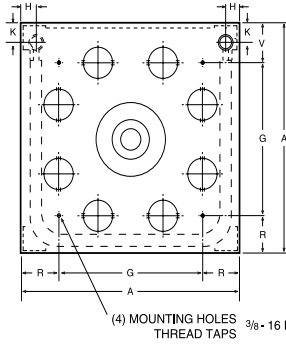

UH-1M (Qty 1)

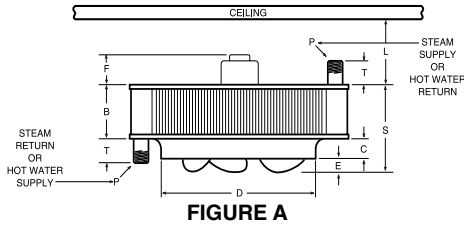
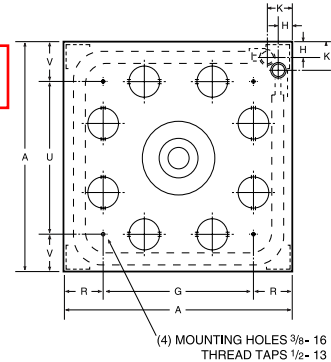

FIGURE A

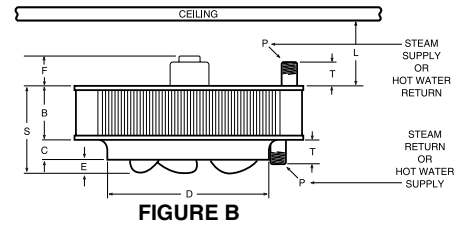

FIGURE B

FIGURE A — MODEL “VV” UNIT HEATER ROUGHING-IN DIMENSIONS

Unit Capacity (MBH)	Fan Dia. inches (mm)	A inches (mm)	B inches (mm)	C inches (mm)	D inches (mm)	E inches (mm)	F inches (mm)	G inches (mm)	H inches (mm)	K inches (mm)	L Min inches (mm)	P NPT inches (mm)	R inches (mm)	S inches (mm)	T inches (mm)	U inches (mm)	V inches (mm)	Approx. Ship Wt. lbs (kg)
40	11-1/4 (286)	18-1/4 (464)	4-5/8 (117)	1-1/4 (32)	11-3/4 (298)	3/4 (19)	4 (102)	11 (279)	1-3/8 (35)	1-7/8 (48)	7 (178)	1-1/2 (38)	3-5/8 (92)	6-5/8 (168)	2-3/4 (60)	11 (279)	3-5/8 (92)	32 (15)
62	13-1/2 (343)	21-1/4 (540)	4-5/8 (117)	1-5/8 (41)	14 (356)	1 (25)	4 (102)	14 (356)	1-3/8 (35)	1-7/8 (48)	7 (178)	1-1/2 (38)	3-5/8 (92)	7-1/8 (181)	2-3/4 (60)	14 (356)	3-5/8 (92)	40 (18)
77	13-1/2 (343)	21-1/4 (540)	6-1/8 (156)	1-5/8 (41)	14 (356)	1 (25)	3 (76)	14 (356)	1-3/8 (35)	1-7/8 (48)	7 (178)	1-1/2 (38)	3-5/8 (92)	8-5/8 (219)	2-3/4 (60)	14 (356)	3-5/8 (92)	43 (20)

FIGURE B — MODEL “VV” UNIT HEATER ROUGHING-IN DIMENSIONS

Unit Capacity (MBH)	Fan Dia. inches (mm)	A inches (mm)	B inches (mm)	C inches (mm)	D inches (mm)	E inches (mm)	F inches (mm)	G inches (mm)	H inches (mm)	K inches (mm)	L Min inches (mm)	P NPT inches (mm)	R inches (mm)	S inches (mm)	T inches (mm)	U inches (mm)	V inches (mm)	Approx. Ship Wt. lbs (kg)
104	16-3/4 (425)	25-1/4 (641)	6-1/8 (156)	2 (51)	17-1/2 (445)	1-1/8 (29)	3 (76)	17 (432)	1-3/8 (35)	2-3/4 (70)	7 (178)	1-1/2 (38)	4-1/8 (105)	9-1/8 (232)	2-3/4 (60)	17 (432)	4-1/8 (105)	63 (29)
125	16-3/4 (425)	25-1/4 (641)	6-1/8 (156)	2 (51)	17-1/2 (445)	1-3/4 (44)	3 (76)	17 (432)	1-3/8 (35)	2-3/4 (70)	7 (178)	1-1/2 (38)	4-1/8 (105)	9-3/4 (248)	2-3/4 (60)	17 (432)	4-1/8 (105)	64 (29)
144	19-3/4 (502)	29-1/2 (749)	6-1/8 (156)	2-3/8 (60)	20-5/8 (524)	1-1/4 (32)	4 (102)	20-1/2 (521)	1-3/4 (44)	3-1/2 (89)	7 (178)	2 (51)	4-1/2 (114)	9-5/8 (244)	2-3/4 (60)	20-1/2 (521)	4-1/2 (114)	80 (36)
164	19-3/4 (502)	29-1/2 (749)	6-1/8 (156)	2-3/8 (60)	20-5/8 (524)	1-3/4 (44)	4 (102)	20-1/2 (521)	1-3/4 (44)	3-1/2 (89)	7 (178)	2 (51)	4-1/2 (114)	10-1/8 (257)	2-3/4 (60)	20-1/2 (521)	4-1/2 (114)	80 (36)
200	19-3/4 (502)	29-1/2 (749)	7-5/8 (194)	2-3/8 (60)	20-5/8 (524)	2 (51)	4 (102)	20-1/2 (521)	1-3/4 (44)	3-1/2 (89)	7 (178)	2 (51)	4-1/2 (114)	12 (305)	2-3/4 (60)	20-1/2 (521)	4-1/2 (114)	86 (39)
237	25-1/4 (641)	37-1/2 (953)	7-5/8 (194)	3 (76)	26-3/8 (670)	1 (25)	3-1/2 (89)	28 (711)	1-3/4 (44)	3-1/2 (89)	7 (178)	2 (51)	4-3/4 (121)	11-5/8 (295)	2-3/4 (60)	18 (457)	9-3/4 (248)	134 (61)
285	25-1/4 (641)	37-1/2 (953)	7-5/8 (194)	3 (76)	26-3/8 (670)	1-1/4 (32)	3-1/2 (89)	28 (711)	1-3/4 (44)	3-1/2 (89)	7 (178)	2 (51)	4-3/4 (121)	11-3/4 (298)	2-3/4 (60)	18 (457)	9-3/4 (248)	139 (63)
317	25-1/4 (641)	37-1/2 (953)	7-5/8 (194)	3 (76)	26-3/8 (670)	2-1/8 (54)	4 (102)	28 (711)	1-3/4 (44)	3-1/2 (89)	7 (178)	2 (51)	4-3/4 (121)	12-3/4 (324)	2-3/4 (60)	18 (457)	9-3/4 (248)	139 (63)
367	25-1/4 (641)	37-1/2 (953)	9-1/8 (232)	3 (76)	26-3/8 (670)	2 (51)	3-1/2 (89)	28 (711)	1-3/4 (44)	3-1/2 (89)	7 (178)	2 (51)	4-3/4 (121)	14-1/8 (359)	2-3/4 (60)	18 (457)	9-3/4 (248)	146 (66)
495	30-1/2 (775)	42 (1067)	9-1/8 (232)	3-1/2 (89)	31-1/4 (794)	1-5/8 (41)	3 (76)	30 (762)	2-1/4 (57)	4-1/4 (108)	7 (178)	2-1/2 (64)	6 (152)	14-1/4 (362)	3 (76)	30 (762)	6 (152)	294 (133)
585	30-1/2 (775)	42 (1067)	12-1/8 (308)	3-1/2 (89)	31-1/4 (794)	2-1/8 (54)	3 (76)	30 (762)	2-1/4 (57)	4-1/4 (108)	7 (178)	2-1/2 (64)	6 (152)	17-3/4 (451)	3 (76)	30 (762)	6 (152)	307 (139)
700	30-1/2 (775)	42 (1067)	13-5/8 (346)	3-1/2 (89)	31-1/4 (794)	3 (76)	4 (102)	30 (762)	2-1/4 (57)	4-1/4 (108)	7 (178)	2-1/2 (64)	6 (152)	20-1/4 (514)	3 (76)	30 (762)	6 (152)	366 (166)



A MESTEK COMPANY

Sales Office 260 North Elm Street
Westfield, Massachusetts 01085
Dial (413) 568-9571 Fax (413) 564-5661
www.vulcanrad.com

PROJECT: _____
LOCATION: _____
ARCHITECT: _____
ENGINEER: _____
CONTRACTOR: _____
PO NUMBER: _____
DATE: _____



Standard Output Units

Hot Water Performance Data

Model/ Unit Size	Water Temp Drop	Output MBH	GPM	H ₂ O Pressure Drop	Final Air Temp	Motor HP†	Motor RPM	Nominal CFM	Outlet Velocity	Sound Rating
VV-40	10°F	28.8	5.93	.37	104.6°F	1/40	1550	595	877	I
	20°F	22.7	2.34	.06	95.2°F					
	30°F	16.7	1.15	.02	85.9°F					
VV-40*	10°F	22.9	4.71	.24	108.3°F	1/40	1150	436	658	I
	20°F	18.1	1.87	.04	98.3°F					
	30°F	13.4	.92	.01	88.4°F					
VV-62	10°F	48.1	9.92	1.05	104.8°F	1/20	1550	998	1005	II
	20°F	39.6	4.08	.19	96.9°F					
	30°F	31.1	2.14	.06	89.0°F					
VV-62*	10°F	38.1	7.85	.67	109.7°F	1/20	1150	706	727	II
	20°F	31.5	3.24	.13	101.1°F					
	30°F	24.8	1.71	.04	92.4°F					
VV-77	10°F	58.7	12.11	.98	105.1°F	1/20	1550	1200	1220	II
	20°F	48.4	4.99	.18	97.2°F					
	30°F	38.1	2.62	.05	89.3°F					
VV-77*	10°F	46.5	9.59	.63	110.0°F	1/20	1150	858	894	II
	20°F	38.5	3.97	.12	101.2°F					
	30°F	30.5	2.09	.03	92.7°F					
VV-104	10°F	77.2	15.91	2.06	106.6°F	1/8	1070	1528	980	II
	20°F	68.3	7.03	.44	101.2°F					
	30°F	59.3	4.08	.16	95.8°F					
VV-104*	10°F	63.7	13.13	1.43	108.6°F	1/8	850	1208	783	II
	20°F	56.5	5.82	.31	103.1°F					
	30°F	49.2	3.38	.11	97.6°F					
VV-125	10°F	94.9	19.55	3.04	108.9°F	1/6	1100	1790	1170	III
	20°F	83.7	8.63	.65	103.1°F					
	30°F	72.5	4.98	.23	97.3°F					
VV-144	10°F	117.6	24.24	4.32	108.8°F	1/6	1100	2220	1045	III
	20°F	105.2	10.84	.96	103.7°F					
	30°F	92.8	6.38	.36	98.5°F					

Performance based on 200°F EWT, 20°F TD, 60°F EAT. Performance at 10°F & 30°F TD is also shown.
For capacities at other conditions, refer to catalog.

*Speed controller option is required for reduced ratings.

†Motor HP listed is applicable to standard motor type only. For explosion proof motor HP, see Installation Manual.

Horizontal Unit Heaters – Submittal

HVD-16

Dimensional Data

UH-2M (Qty - 1)

Steam and Hotwater Coil



MODELS HV-18 THRU 360 (HEADER TYPE)

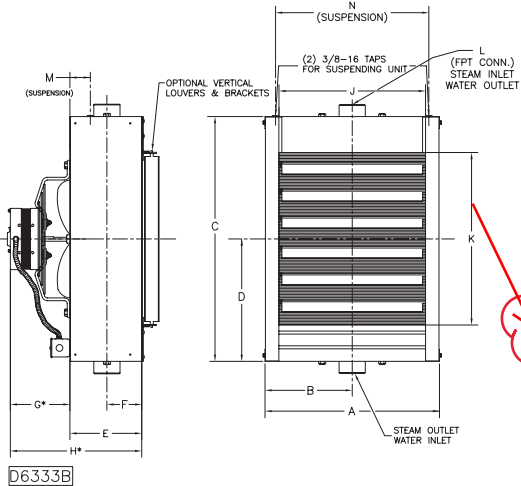

Unit Size	A inches (mm)	B inches (mm)	C inches (mm)	D inches (mm)	E inches (mm)	F inches (mm)	G* inches (mm)	H* inches (mm)	J inches (mm)	K inches (mm)	L inches (mm)	M inches (mm)	N inches (mm)	Number of Louvers	Nom. Fan Diam. inches (mm)	Approx. Ship Wt. lbs. (kg)
18	14 ⁷ / ₈ (371)	7 ⁷ / ₁₆ (186)	15 (381)	7 ¹ / ₂ (191)	6 ¹ / ₈ (156)	2 ¹ / ₈ (75)	3 ¹ / ₄ (83)	9 ³ / ₈ (238)	12 ¹ / ₄ (311)	9 ¹ / ₂ (241)	1 ¹ / ₄ (32)	2 ¹ / ₄ (57)	12 ⁷ / ₈ (327)	4	9 (229)	26 (11.8)
24	14 ⁷ / ₈ (371)	7 ⁷ / ₁₆ (186)	18 (457)	9 (229)	6 ¹ / ₈ (156)	2 ¹ / ₈ (75)	3 ¹ / ₄ (83)	9 ³ / ₈ (238)	12 ¹ / ₄ (311)	12 ¹ / ₂ (318)	1 ¹ / ₄ (32)	2 ¹ / ₄ (57)	12 ⁷ / ₈ (327)	5	10 (254)	30 (13.6)
36	17 ¹ / ₈ (435)	8 ⁹ / ₁₆ (217)	20 ¹ / ₂ (521)	10 ¹ / ₄ (260)	5 ⁷ / ₈ (149)	2 ¹ / ₈ (75)	5 ¹ / ₁₆ (144)	11 ⁷ / ₁₆ (291)	14 ³ / ₄ (375)	15 (381)	1 ¹ / ₄ (32)	1 ³ / ₄ (44)	15 ³ / ₈ (391)	6	12 (305)	41 (18.6)
48	17 ¹ / ₈ (435)	8 ⁹ / ₁₆ (217)	20 ¹ / ₂ (521)	10 ¹ / ₄ (260)	5 ⁷ / ₈ (149)	2 ¹ / ₈ (75)	5 ¹ / ₁₆ (144)	10 ¹ / ₈ (278)	14 ³ / ₄ (375)	15 (381)	1 ¹ / ₄ (32)	1 ³ / ₄ (44)	15 ³ / ₈ (391)	6	12 (305)	41 (18.6)
60	18 ³ / ₈ (467)	9 ⁹ / ₁₆ (233)	21 ³ / ₄ (552)	10 ⁷ / ₈ (276)	6 (152)	2 ¹ / ₈ (75)	5 ¹ / ₁₆ (129)	11 ¹ / ₁₆ (281)	16 (406)	16 ¹ / ₄ (413)	1 ¹ / ₄ (32)	1 ³ / ₄ (44)	16 ⁵ / ₈ (422)	7	14 (356)	44 (19.9)
72	20 ⁷ / ₈ (530)	10 ⁷ / ₈ (265)	24 ¹ / ₄ (616)	12 ¹ / ₂ (308)	6 ¹ / ₈ (156)	2 ¹ / ₈ (75)	5 ¹ / ₁₆ (144)	11 ³ / ₁₆ (300)	18 ¹ / ₂ (470)	18 ³ / ₄ (476)	1 ¹ / ₄ (32)	1 ³ / ₄ (44)	19 ¹ / ₈ (486)	8	14 (356)	47 (21.3)
84	20 ⁷ / ₈ (530)	10 ⁷ / ₈ (265)	25 ¹ / ₄ (641)	12 ⁵ / ₈ (321)	6 ¹ / ₈ (160)	3 ³ / ₈ (81)	7 ¹ / ₂ (191)	13 ¹ / ₁₆ (351)	17 ¹ / ₄ (438)	17 ¹ / ₂ (445)	1 ¹ / ₄ (38)	1 ³ / ₄ (44)	17 ¹ / ₈ (454)	8	16 (406)	49 (22.2)
96	20 ⁷ / ₈ (530)	10 ⁷ / ₈ (265)	25 ¹ / ₄ (641)	12 ⁵ / ₈ (321)	6 ¹ / ₈ (160)	3 ³ / ₈ (81)	7 ¹ / ₂ (191)	13 ¹ / ₁₆ (351)	17 ¹ / ₄ (438)	18 ¹ / ₂ (476)	1 ¹ / ₄ (38)	1 ³ / ₄ (44)	19 ¹ / ₈ (486)	8	16 (457)	59 (26.7)
108	23 ³ / ₈ (594)	11 ¹ / ₁₆ (297)	27 ³ / ₄ (705)	13 ³ / ₈ (352)	6 ⁵ / ₈ (160)	3 ³ / ₈ (81)	7 ³ / ₈ (194)	13 ³ / ₁₆ (349)	21 (533)	21 ¹ / ₄ (540)	1 ¹ / ₂ (38)	1 ³ / ₄ (44)	21 ¹ / ₈ (549)	9	18 (457)	74 (33.5)
132	23 ³ / ₈ (594)	11 ¹ / ₁₆ (297)	27 ³ / ₄ (705)	13 ³ / ₈ (352)	6 ⁵ / ₈ (160)	3 ³ / ₈ (81)	7 ³ / ₈ (194)	13 ³ / ₁₆ (349)	21 (533)	21 ¹ / ₄ (540)	1 ¹ / ₂ (38)	1 ³ / ₄ (44)	21 ¹ / ₈ (549)	9	18 (457)	74 (33.5)
144	23 ³ / ₈ (594)	11 ¹ / ₁₆ (297)	27 ³ / ₄ (705)	13 ³ / ₈ (352)	6 ⁵ / ₈ (160)	3 ³ / ₈ (81)	7 ³ / ₈ (194)	13 ³ / ₁₆ (349)	21 (533)	21 ¹ / ₄ (540)	1 ¹ / ₂ (38)	1 ³ / ₄ (44)	21 ¹ / ₈ (549)	9	18 (457)	74 (33.5)
156	24 ¹ / ₂ (625)	12 ³ / ₁₆ (313)	29 (737)	14 ¹ / ₂ (368)	6 ³ / ₈ (162)	3 ³ / ₈ (81)	7 ¹ / ₁₆ (194)	13 ³ / ₁₆ (349)	22 ¹ / ₄ (565)	22 ¹ / ₂ (572)	1 ¹ / ₂ (38)	1 ³ / ₄ (44)	22 ⁷ / ₈ (581)	9	18 (457)	90 (40.8)
204	27 ¹ / ₈ (708)	13 ¹ / ₁₆ (354)	30 ¹ / ₄ (768)	15 ¹ / ₂ (384)	8 ¹ / ₈ (206)	3 ³ / ₈ (81)	7 ³ / ₈ (194)	14 (356)	25 ¹ / ₂ (648)	23 ¹ / ₂ (603)	2 (51)	1 ³ / ₄ (44)	26 ¹ / ₈ (664)	10	20 (508)	143 (65)
240	27 ¹ / ₈ (708)	13 ¹ / ₁₆ (354)	30 ¹ / ₄ (768)	15 ¹ / ₂ (384)	8 ¹ / ₈ (206)	3 ³ / ₈ (81)	9 ⁹ / ₁₆ (244)	17 ³ / ₁₆ (451)	25 ¹ / ₂ (648)	23 ³ / ₄ (603)	2 (51)	1 ³ / ₄ (44)	26 ¹ / ₈ (664)	10	20 (508)	154 (70)
280	30 ³ / ₈ (848)	16 ¹ / ₁₆ (424)	37 ³ / ₄ (959)	18 ⁷ / ₈ (479)	9 (229)	3 ³ / ₈ (81)	9 ⁹ / ₁₆ (244)	18 ³ / ₈ (473)	31 (787)	31 ¹ / ₄ (794)	2 (51)	1 ³ / ₄ (44)	31 ³ / ₈ (803)	13	24 (610)	203 (92)

* APPLIES TO STANDARD MOTOR WITH STANDARD FAN GUARD. WHEN OPTIONAL MOTORS OR OSHA FAN GUARDS ARE REQUESTED, DIMENSIONS WILL CHANGE ACCORDING TO THE SUBSTITUTIONS MADE.

- NOTES: 1. OSHA guard standard on models HV-18 thru HV-48 (dimensions shown in table).
 2. Standard motor and standard guard shown in both tables.
 3. Optional OSHA guards available for all units with standard single phase motors.
 4. All three phase and explosion proof motors are shelf mounted.

Serpentine Hotwater Coil

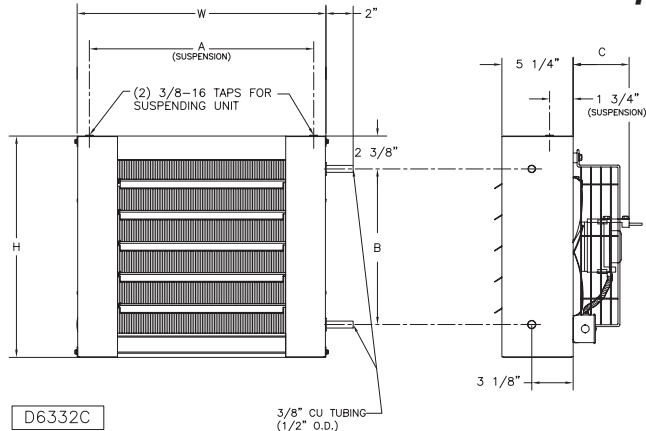

MODELS HV-108A THRU 136A

Unit Size	H inches (mm)	W inches (mm)	A inches (mm)	B inches (mm)	C inches (mm)	Number of Louvers	Nominal Fan Diameter inches (mm)	Approx. Ship Wt. lb. (kg)
108A	16 (406)	18 (457)	16 ¹ / ₃₂ (412)	11 ¹ / ₄ (286)	4 ¹ / ₄ (108)	5	9 (229)	22 (10.0)
118A	16 (406)	18 (457)	16 ¹ / ₃₂ (412)	11 ¹ / ₄ (286)	4 ¹ / ₄ (108)	5	10 (254)	24 (10.9)
125A	16 (406)	18 (457)	16 ¹ / ₃₂ (412)	11 ¹ / ₄ (286)	4 ¹ / ₄ (108)	5	10 (254)	25 (11.3)
136A*	18 ¹ / ₂ (470)	20 ¹ / ₂ (521)	18 ² / ₃₂ (475)	13 ³ / ₄ (349)	5 ¹ / ₁₆ (144)	6	12 (305)	31 (14.0)

* Dimension "C" is to back of motor, not motor conduit connector as shown.
 NOTE: OSHA type fan guard standard on models HV-108A thru HV-136A.



A MESTEK COMPANY

260 North Elm Street
 Westfield, Massachusetts 01085
 (413) 568-9571 • Fax (413) 564-5661
 www.vulcanrad.com

PROJECT: _____
 LOCATION: _____
 ARCHITECT: _____
 ENGINEER: _____
 CONTRACTOR: _____
 PO NUMBER: _____
 DATE: _____



Steam and Hot Water Coil Specifications

GENERAL

Furnish and install where indicated or scheduled on plans horizontal steam/hot water unit heater. Unit shall be equipped as specified herein. All units shall be installed in a neat and workmanlike manner in accordance with this specification and the manufacturer's installation instructions.

CASING

Casings shall be 20-gauge die-formed steel. Paint finish shall be of lead-free, chromate free, polyester melamine resin base. Finish shall be baked at 400°F.

COIL SIZES 18 - 360

Coil elements and headers shall be of heavy wall drawn seamless copper tubing. Element tubes shall be brazed into extruded header junctions. Pipe connection saddles shall be of cast bronze. Aluminum fins shall have drawn collars to assure permanent bond with expanded element tubes and exact spacing. All Element Assemblies are submersion tested at the factory at 200 PSI. Under maximum conditions, coils are rated at 150 PSI at 366°F for steam and 150 PSI at 320°F for hot water. We recommend operating pressure of 75 PSI at 320°F for long life.

MOTORS

Motors shall be totally enclosed fan cooled, resilient mounted with class "B" windings. All motors shall be designed for horizontal mounting. Motors under 1/3 HP are totally enclosed, frame mounted, 115/1/60 with thermal overload protection and permanently lubricated sleeve bearings with optional solid state speed controller available. 1/3 HP (115/1/60) motors are open frame construction, with thermal overload protection and ball bearings. 1/3 HP at (230 Volt) and all 1/2 HP motors are open frame construction, with thermal overload protection and ball bearings. 1/3 and 1/2 HP motors are available in single and three phase in open frame construction or explosion-proof housings, all the above are available as options.

EXPLOSION PROOF MOTORS

An enclosed motor whose enclosure is designed and constructed to withstand an explosion of a specified gas or vapor which may occur within the motor and to prevent the ignition of this gas or vapor surrounding the machine.

Horizontal unit heater motors comply with the National Electrical Code classification as follows:

- Class I, Group D; all sizes
- Class II, Group F; all sizes
- Class II, Group G; all sizes
- Division I & II Installations
- T-code (T3B)

Explosion proof equipment is not generally available for Class I, Group A and B and it is necessary to isolate motors from the hazardous area. All explosion proof motors are shelf mounted.

FANS

Fans shall be of aluminum blade, hub type designed and balanced to assure maximum air delivery, low motor horsepower requirements and quiet operation. Blades are spark proof.

FAN GUARDS

Fan guards shall be welded steel, zinc plated or painted. Units mounted below 8 feet from floor must be equipped with an OSHA fan guard to meet ETL and OSHA requirements. OSHA fan guard standard on sizes 18 thru 48.

AIR DEFLECTION LOUVERS

Units shall be equipped with horizontal, individually adjustable louvers. Vertical louvers for four-way air control shall be available as an optional extra.

Serpentine Coil Specifications

GENERAL

Furnish and install, where indicated or scheduled on plans, Vulcan Model HVA horizontal hot water unit heaters. Unit shall be equipped as specified herein. All units shall be installed in a neat and workmanlike manner in accordance with this specification and the manufacturer's installation instructions.

CASING

Casings shall be 20-gauge die-formed steel. Paint finish shall be of lead-free, chromate free, polyester melamine resin base. Finish shall be baked at 400°F.

COIL MODELS 108A - 136A

Coil is a serpentine design with seamless copper tubing. Aluminum fins shall have drawn collars to assure permanent bond with expanded tubes. Tubing connection shall be 3/8 in copper tubing, type "M" (.500 OD). Coils shall be factory tested at 200 PSI. Coils have a max operating entering water temperature of 320°F.

MOTORS

Motors shall be totally enclosed fan cooled, resilient mounted with class "B" windings. All motors shall be designed for horizontal mounting.

FANS

Fans shall be of aluminum blade type, designed and balanced to assure maximum air delivery, low motor horsepower requirements and quiet operation.

OSHA FAN GUARDS

- OSHA fan guards shall be welded steel, zinc plated or painted.
- OSHA fan guard standard on sizes 108A thru 136A.

AIR DEFLECTION LOUVERS

Units shall be equipped with horizontal, individually adjustable louvers.

Motor Characteristics

TOTALLY ENCLOSED MOTOR TYPE

Unit Sizes	AMP	MCA	HP	RPM
115/1/60				
18, 24, 108A, 118A	0.8	1	16W*	1550
136A	1.4	1.8	1/20*	1000
36, 125A	1.2	1.5	25W*	1550
48, 60, 72	1.4	1.8	1/20*	1000
84, 96, 108	2.2	2.8	1/12*	1000
120, 132, 144, 156, 180, 204, 240	4.5	5.6	1/3	1140
280, 300, 360	5.4	6.8	1/2	1100
230/1/60				
18, 24, 108A, 118A	0.4	0.5	16W	1550
136A	1.4	1.8	1/20†	1000
36, 125A	0.6	0.8	25W	1550
48, 60, 72	1.4	1.8	1/20†	1000
84, 96, 108	2.2	2.8	1/12†	1000
120, 132, 144, 156, 180, 204, 240	4.5	5.6	1/3†	1140
280, 300, 360	5.4	6.8	1/2†	1100
208-230/460/3/60				
48, 60, 72, 84, 96, 108, 120, 132, 144, 156, 180, 204, 240, 280, 300, 360	2.6-2.6/1.3	3.3-3.3/1.6	1/2**	1140

*Optional variable speed switch is available.

**These motors are without thermal overload protection.

Motors without thermal overload protection must be installed with optional manual starter or field provided overload protection.

NOTE 1: All motors are constant speed and operate at top speed as indicated in motor data. Unit sizes 18 through 108, including 108A, 118A, 125A and 136A can be run at reduced speed with addition of optional variable speed switch. This switch is factory-calibrated for low and high speed ratings, with intermediate speeds infinitely controllable. Models 120 through 360 operate at constant speed as indicated in motor data. All 1/4 HP motors are PSC.

NOTE 2: Motors under 1/3 HP are totally enclosed, frame mounted, 115/1/60 with thermal overload protection and permanently lubricated sleeve bearings with optional speed controller available. 1/3 HP (115/1/60) motors are open frame constant speed with thermal over-load protection and ball bearings. 1/3 HP (230 Volt) and 1/2 HP (230 Volt) motors are open frame constant speed with thermal overload protection and ball bearings.

EXPLOSION PROOF WITH THERMAL OVERLOAD MOTOR TYPE

Unit Sizes	AMP	MCA	HP	RPM
115/1/60				
48, 60, 72, 84, 96, 108, 120, 132	3.7	4.6	1/6	1140
144, 156, 180, 204	5.4	6.8	1/4	1140
240	7.8	9.8	1/3***	1140
280, 300, 360	9.6	12.0	1/2***	1140
230/1/60				
48, 60, 72, 84, 96, 108, 120, 132	3.7	4.6	1/6†	1140
144, 156, 180, 204	5.4	6.8	1/4†	1140
240	3.9	4.9	1/3***	1140
280, 300, 360	4.8	6.0	1/2***	1140
230/460/3/60				
144, 156, 180, 204, 240, 280, 300, 360	2.2/1.1	2.8/1.4	1/3	1140

***These motors are 115/230 volts.

†230/1/60 unit has 115/1/60 motor supplied with field installed stepdown transformer.

NOTE 3: 1/3 and 1/2 HP motors are available as 230 Volt single and 3 phase in open frame and explosion-proof housings, all available as options. 1/3 and 1/2 HP motors operate at single speed only.

NOTE 4: Stated AMP draw is full load amp (FLA). AMP draw varies by motor manufacturer ± .2 AMPS. Verify FLA per unit motor data plate.

CAUTION: Select appropriate AMP and MCA for the multiple voltage motors. For example, the AMP and MCA for Models 360 with a 460 volt Totally Enclosed motor is 1.3 and 1.6 respectively.