

SIZE OF LEGEND LETTERS		
OUTSIDE DIA. OF PIPE OR COVERING (INCH)	LENGTH OF COLOR FIELD (A) (INCH)	LETTER HEIGHT (B) (INCH)
3/4 to 1-1/4	8	1/2
1-1/2 to 2	8	3/4
2-1/2 to 6	12	1-1/4
8 to 10	24	2-1/2
over 10	32	3-1/2

- NOTE**
- SEE PAINTING SPECIFICATION FOR FINISH COLOR OF PIPE.
 - LABELS SHALL BE INSTALLED AT A MINIMUM OF EVERY 50' AND AT ANY WALL OR FLOOR PENETRATION.
 - INDICATE FLOW ARROWS AT EACH PIPE DESIGNATIONS SIMILAR TO DIAGRAM PROVIDED.

B7 PIPING SYSTEM IDENTIFICATION
NOT TO SCALE

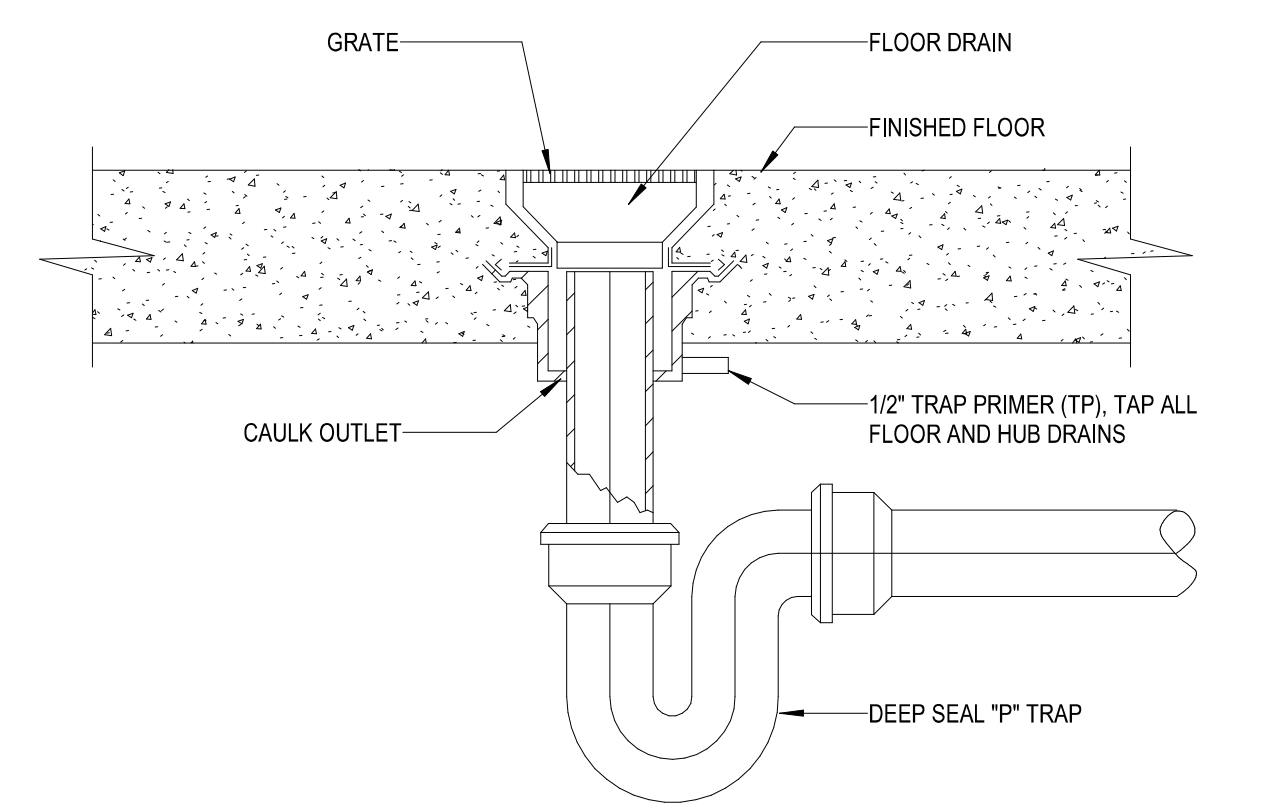

B8 TYPICAL FLOOR DRAIN DETAIL
NOT TO SCALE

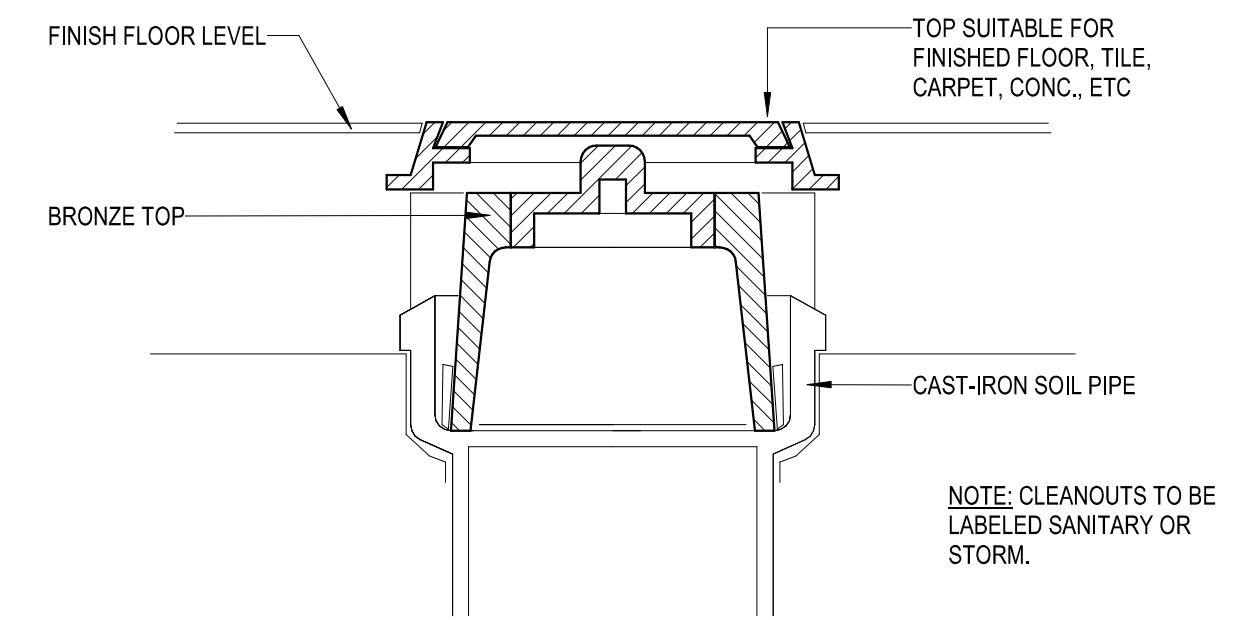

C8 CLEAN OUT DETAIL
NOT TO SCALE

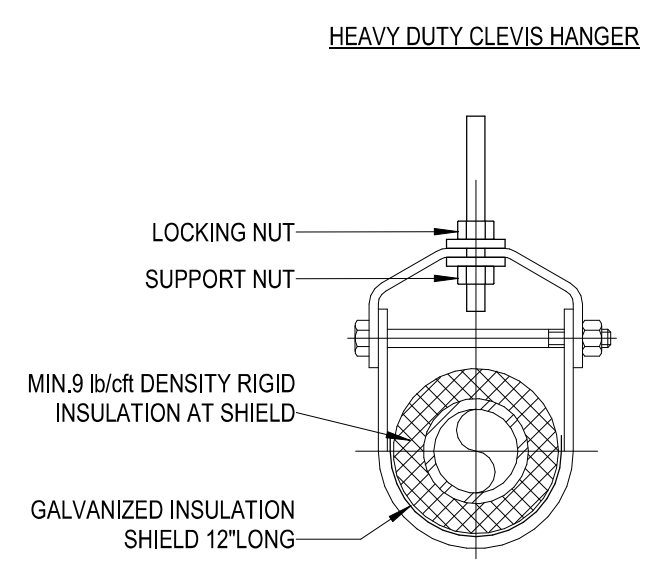

D2 PIPE HANGER SUPPORT DETAIL
NOT TO SCALE

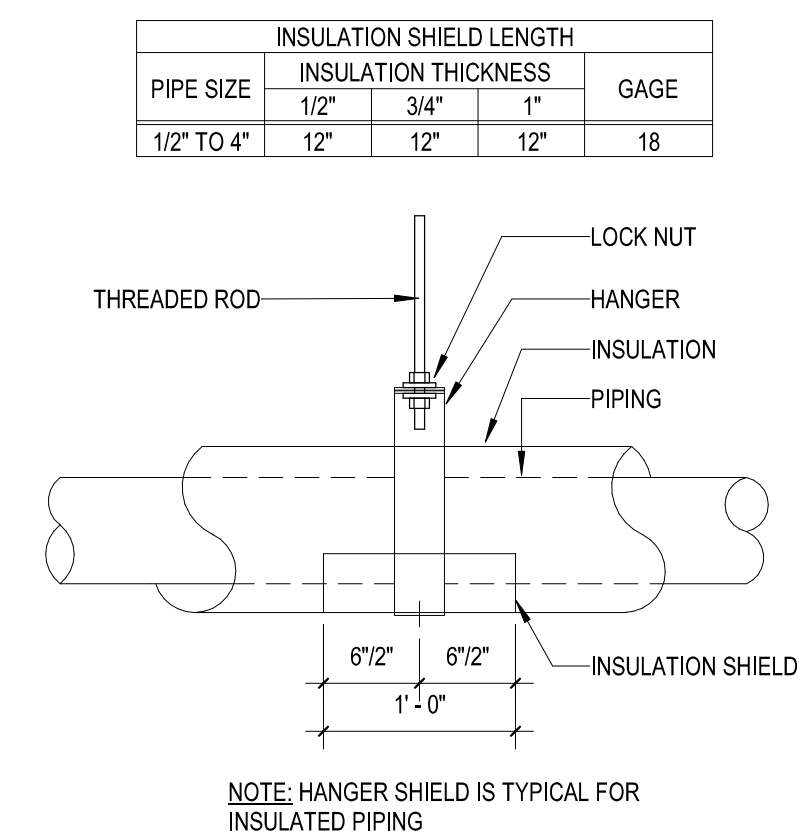

D4 INSULATION SHIELD DETAIL
NOT TO SCALE

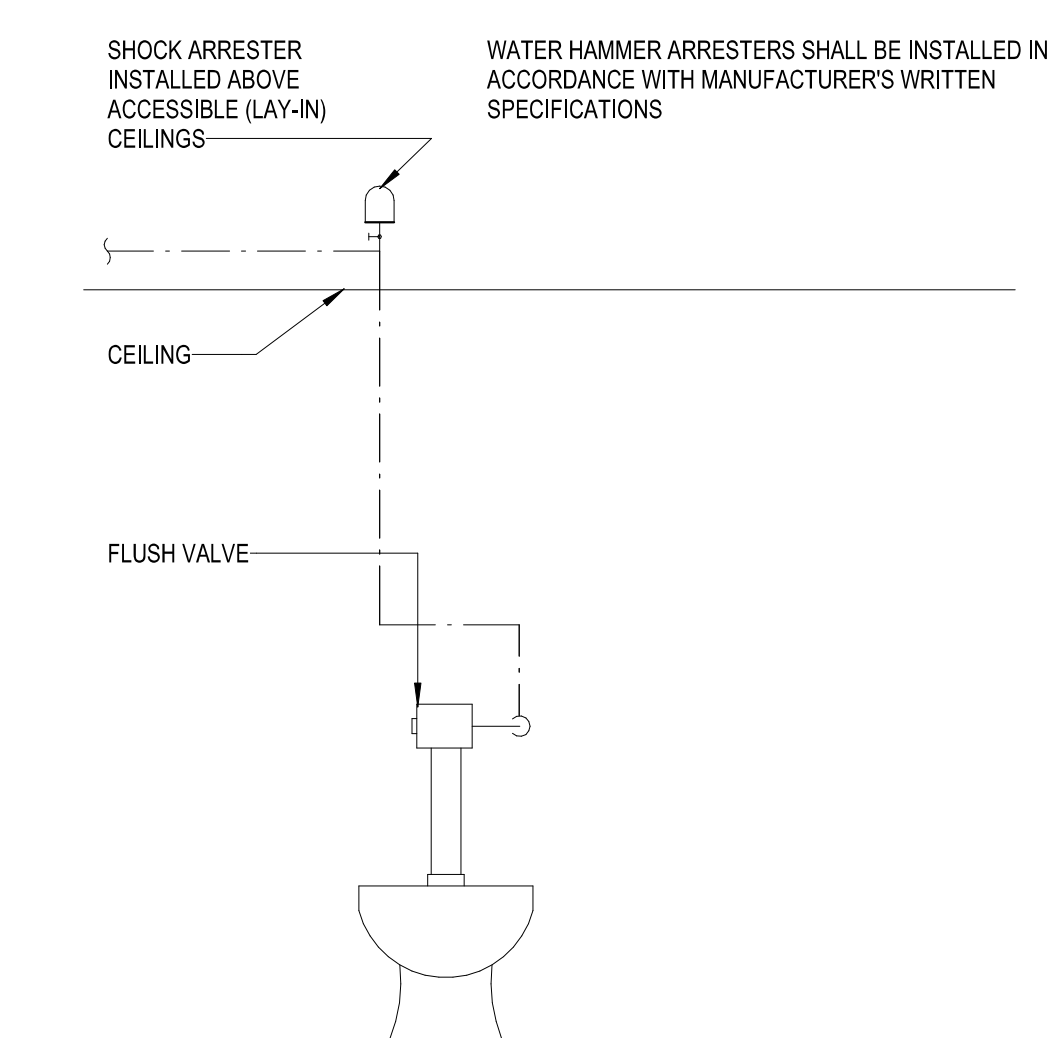

D7 WATER HAMMER ARRESTOR
NOT TO SCALE

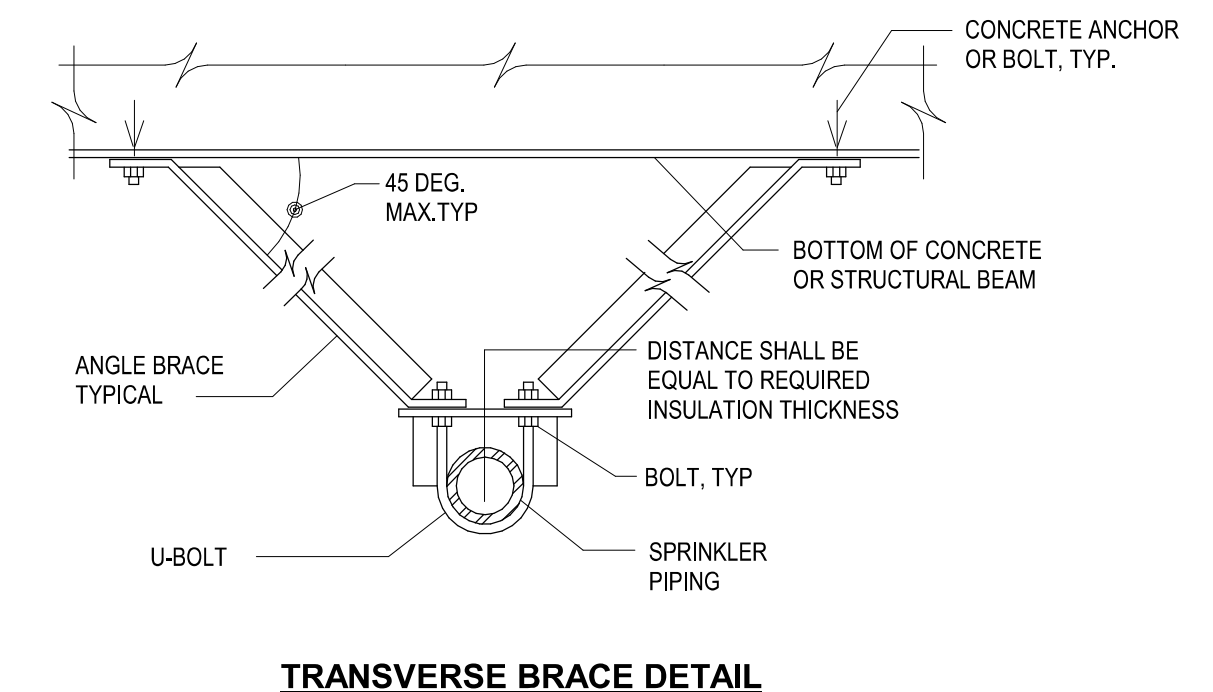

TRANSVERSE BRACE DETAIL

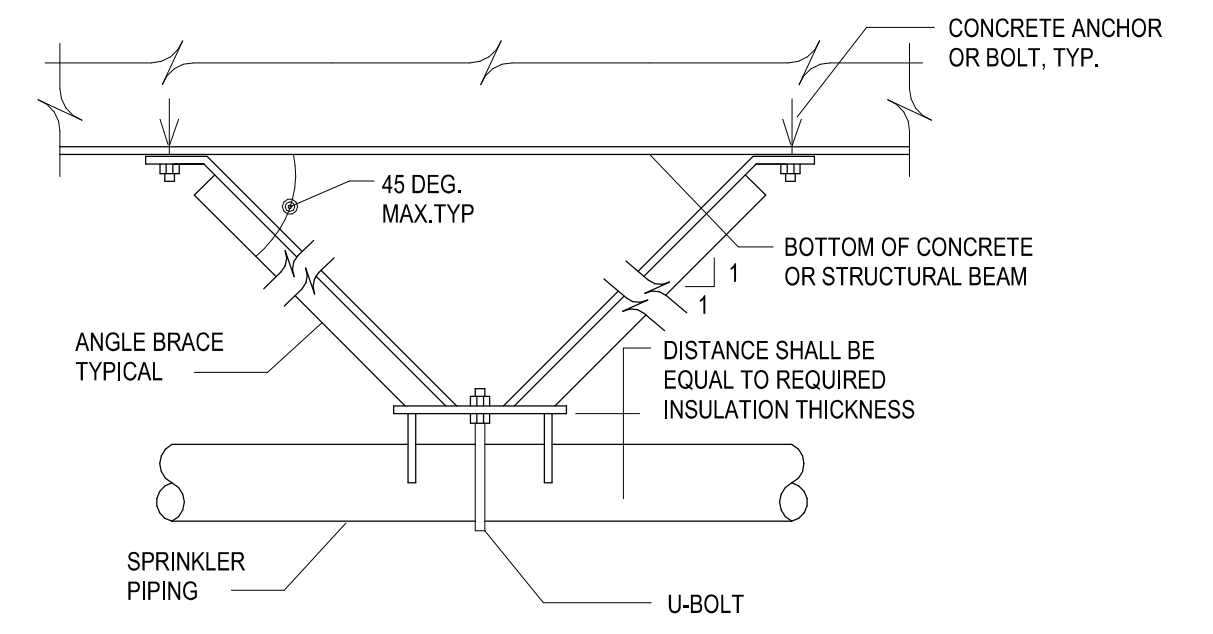

LONGITUDINAL BRACE DETAIL

- NOTES**
- DETAILS SHOWN ARE FOR PIPE BRACING. OTHER EQUIPMENT BRACING SHALL BE SIMILAR.
 - PL. SIZES SHALL BE COORDINATED WITH PIPING, AND EQUIPMENT ACTUAL SIZES.
 - BRACE SIZES, SPACINGS, LOCATIONS, AND ATTACHMENTS SHALL BE AS SPECIFIED. BRACES SHALL BE FULLY COORDINATED WITH STRUCTURAL FRAMING AND WITH ALL OTHER BUILDING MATERIALS AND SERVICES.
 - TRANSVERSE AND LONGITUDINAL BRACES MAY BE COMBINED WHERE REQUIRED TO RESIST MOTIONS IN BOTH DIRECTIONS AT THE SAME TIME.
 - PIPING CLAMPS MAY BE UTILIZED IN LIEU OF WELDING AT BLACK STEEL OR OTHER PIPING MATERIALS.

F8 SEISMIC BRACING DETAIL
NOT TO SCALE

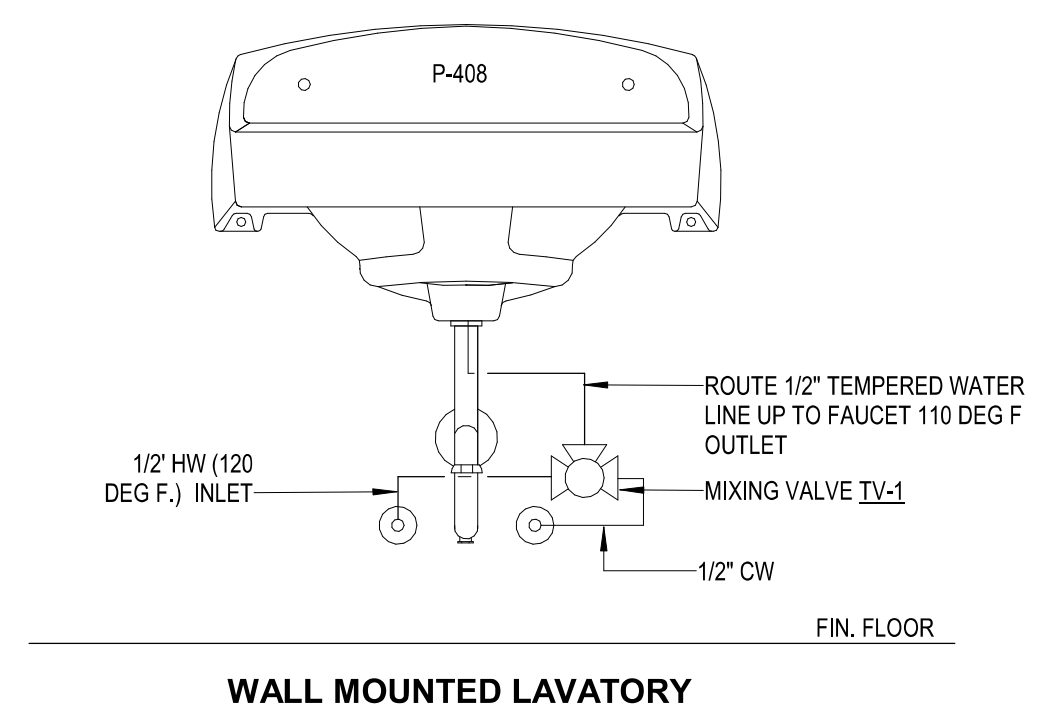

F4 MIXING VALVE FOR LAVATORIES
NOT TO SCALE

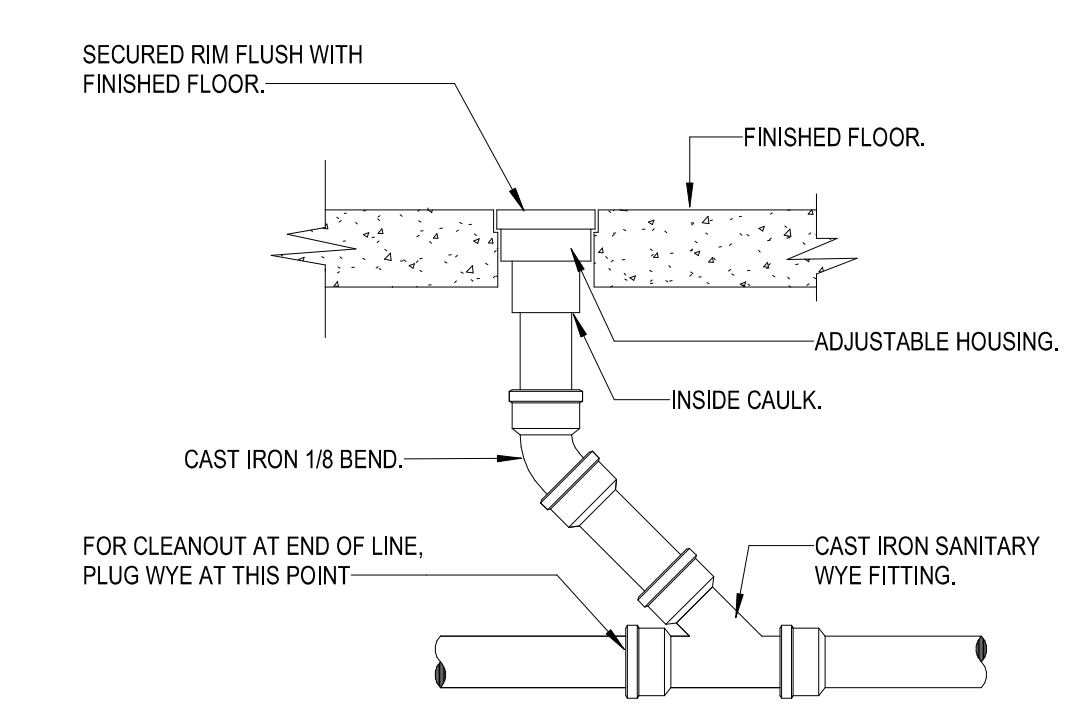

F7 FLOOR CLEANOUT DETAIL
NOT TO SCALE

4/11/2024 2:58:02 PM
BIM 360/19022 - Fayetteville VA Medical Center - Project No. 94-19-003 Renovation of SPS/19022 - PLUMB - R2024.rvt

Revision Number	Revisions:	Date:

CONSULTANTS
CONSULTING STRUCTURAL ENGINEERS

ARCHITECT/ENGINEER OF RECORD

A/E:
HARRELL DESIGN GROUP PC
10720 SIKES PLACE, SUITE 100
CHARLOTTE, NC 28277
704-814-1346
POC: LEE HARRELL PE, LEED AP, QCxP
PRESIDENT
HDG PROJECT: 19022

WWW.HARRELLDG.COM
COPYRIGHT © 2024

STAMP

William G. Graney Jr.
Charlotte, NC
I am approving this document
02/28/2011 16:14:06-04'00'

DRAWING TITLE
PLUMBING DETAILS

APPROVED

PHASE
CONSTRUCTION DOCUMENTS SUBMISSION

FULLY SPRINKLERED

PROJECT TITLE
RENOVATE SPACE FOR LOGISTICS (B-1)

PROJECT NUMBER
564-24-104

BUILDING NUMBER
1

DRAWING NUMBER
PL501-A

LOCATION
FAYETTEVILLE VA MEDICAL CENTER

ISSUE DATE
11 APRIL 2024

CHECKED
WGG

DRAWN
DM

Engineering Service

VETERANS HEALTH CARE SYSTEM OF THE OZARKS

U.S. Department of Veterans Affairs