

Quality People. Building Solutions.

Comfort Systems USA (Arkansas), Inc.
P.O. Box 16620
Little Rock, AR 72231
Phone 501-834-3320
Fax 501-834-5416

Date: 8/14/2023

Return Request: 8/24/2023

Project: Southside HS & JH Additions

Supplier: Airetech

Manufacturer: Markle

Submittal: Electric Unit Heaters

Submittal Number: 23 82 39-01

Drawing # and Installation: Mechanical Drawings

ARCHITECT

Lewis Architects Engineers
11225 Huron Lane, Suite 104
Little Rock, AR 72211
501-223-9302

ENGINEER

Lewis Architects Engineers
11225 Huron Lane, Suite 104
Little Rock, AR 72211
501-223-9302

GENERAL CONTRACTOR

Nabholz
612 Garland St.
Conway, AR 72032
501-505-5800

MECHANICAL SUBCONTRACTOR

Comfort Systems USA (Arkansas), Inc.
9924 Landers Rd.
N. Little Rock, AR 72117
501-834-3320

Notes:

CSUSA PROJECT NO.

23-8009

dpierce@comfortar.com

9924 Landers Rd.
No. Little Rock, AR 72117



SUBMITTAL DATA

EQUIPMENT: Electric Unit Heaters

SPEC SECTION: 23 82 39

TAGS: EH-1 & 2, EDH-1

PROJECT: Southside High School and Junior High Additions

LOCATION: Batesville, AR

ENGINEER:



CONTRACTOR:



DATE: 7/26/2023

SUBMITTED BY: Forrest Moseley
forrest@airetechcorp.com
501-425-6112

SALES ORDER NO.		QUOTE	BGCT6
CUSTOMER		DATE:	07/26/2023
PROJECT	Southside High School and Junior High Addition		
SALES REP	Airetech Corporation		
ENGINEER	Wade Mobbs		
CONTRACTOR	Comfort Systems USA		
SUBMITTED BY	Nick Moore		
APPROVED BY			
APPROVED BY			

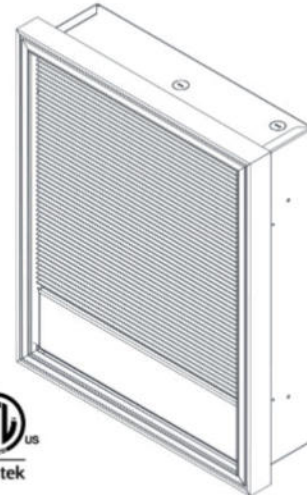

SUBMITTAL DATA SHEET

QTY	MODEL	TAG	WATTAGE	VOLTS	PHASE	AMPS	CFM	DISCONNECT	THERMOSTAT	OPTIONS
1	F3423T	EH-1	3	208	1	14.4	245	Yes	Yes	3420EX34
1	F3425T	EH-2	5	208	1	24	245	Yes	Yes	3420EX34

NOTES/SPECIAL
INSTRUCTIONS:

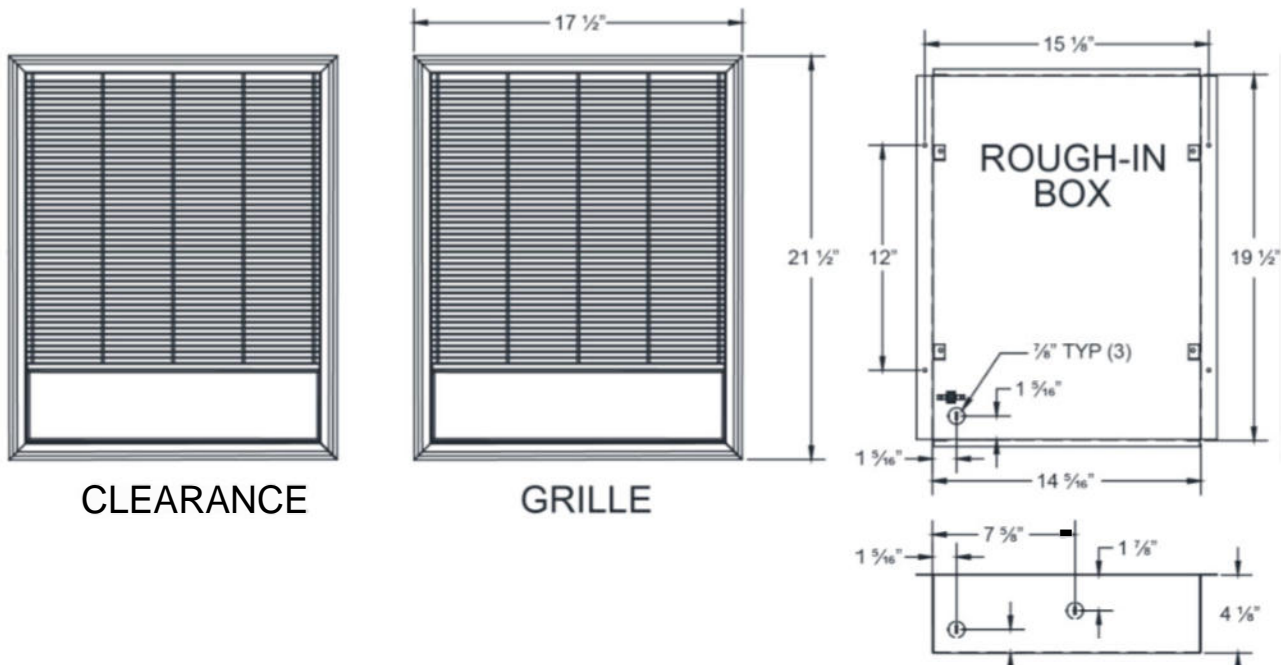

- Heavy 16 gauge steel construction
- Powder coated paint finish
- Steel block fin element
- All units equipped with manual reset thermal limit switch
- Van Axial fan blade produces 245 CFM
- Dual wattage and voltage units available for 208/240 volts
- Surface Mounting Frames available for non-recessed and semi-recessed applications
- Units built with factory installed Disconnecting Tamper-Proof Thermostats

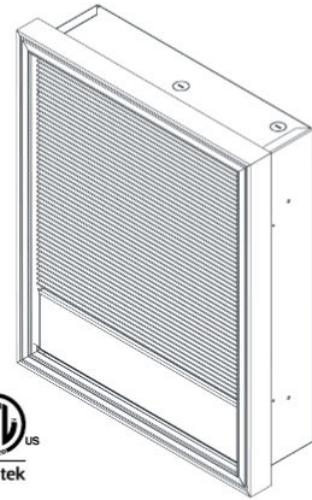

HEATER		WALL BOX		WATTS	BTUs	VOLTS	PH	AMPS	WT. (LBS)		
MFG CATALOG NUMBER	MFG MODEL NUMBER	MFG CATALOG NUMBER	MFG MODEL NUMBER								
SERIES 3420 - ROUGH-IN DIMENSIONS: 19 5/8" H X 14 7/16" W X 4 1/8" D GRILL DIMENSIONS: 21 1/2" H X 17 1/2" W											
06911302	F3422T	06915702	Box 3420	2000	6826	208	1	9.6	41		
06911902	H3422T					240		8.3			
06911702	G3422T					277		7.2			
03846202	J3422T			2000	6826	208	3	5.6			
03846402	K3422T					240		4.8			
06912302	F3423T			06915702	Box 3420	3000	10239	208		1	14.4
06913102	H3423T							240			12.5
06912702	G3423T					3000	10239	277		3	10.8
03238502	J3423T							208			8.3
03846502	K3423T					4000	13652	240		1	7.3
06913302	F3424T							208			19.2
06913802	H3424T					4000	13652	240		3	16.7
06913602	G3424T							277			14.4
06914002	J3424T					5000	17065	208		3	11.1
06914102	K3424T							240			9.6
06914302	F3425T					5000	17065	208		1	24.03
06915102	H3425T	240	20.8								
06914802	G3425T	5000	17065			277	3	18.1			
06915302	J3425T					208		13.9			
06915602	K3425T					240		12.0			

Factory Installed Accessories

Units with transformers must have a contactor. A control transformer with 120V secondary is available on all 3-phase models, 208V/240V 1-phase units up to 3KW, and up to 4KW on 277V. All heaters must be installed with a wall box

MFG MODEL NUMBER	DESCRIPTION	SERIES OPTIONS	
		3420	3450
Suffix - R	Contactor with Coil same as heater	YES	YES
Suffix - R1	Contactor with 24V Coil	YES	YES
Suffix - R2	Contactor with 120V Coil	YES	YES
Suffix - C	Circuit Breakers - all models	NO	YES
Suffix - A1	Control Transformers with 24V Secondary	NO	YES
Suffix - A2	Control Transformers with 120V Secondary	NO	YES

MFG CATALOG NUMBER	MFG MODEL NUMBER	DESCRIPTION	WT. (LBS)
06916002	3420EX34	4" Surface Mounting Sleeve	5
06915902	3420EX16	2" Semi-Recessing Sleeve	4
06915802	3420EX8	1" Semi-Recessing Sleeve	3
06915702	Box 3420	Wall Box for 3420	4

Product Specifications

Contractor shall supply and install heavy duty wall mounted forced air electric heaters of the wattage, voltage and phase as specified. The heater shall so be designed to provide an even distribution of heated air to the space to be heated by drawing return air in the peripheral area of the heater across and through the element which shall then be discharged from the center section of the heater by means of an electric motor and axial flow fan blade. Heaters shall be recessed type to extend no more than 1 ½" from the finished wall or surface mounted to extend no more than 5 ¾" from the finished wall or semi-recessed type to extend no more than 3 ½" from finished wall or semi-recessed type to extend no more than 2 ½" from finished wall.

ENCLOSURE:

Heater front shall withstand 10.8 ft. lbs. (324 poundals) impact and 400 lbs. static force applied to an 8 sq. in. area at center grille location with less than ¼" permanent distortion. The combination return and supply grille assembly shall be constructed of ¼" x ¾" rounded edge horizontal steel louvers which shall be spaced for maximum opening of ¼". Louvers shall be welded at every intersection to three evenly spaced ¼" diameter vertical members and completely framed in a heavy gauge natural anodized Aluminum extrusion. Front assembly shall be attached to the chassis by hidden tamper-resistant (Allen-head) machine screws. All other parts shall be 16 gauge steel Zinc coated, both sides finished in a high gloss or bronze colored baked powder coat finish.

MOTOR:

Motor shall be a permanently lubricated unit bearing, totally enclosed shaded pole type with impedance protection. Motors shall operate at no more than 1400 RPM and shall be same voltage as the heater. A protective shield shall surround the motor to separate return air from heated air

PERFORMANCE:

Heaters shall have a rating of 245 CFM at 660 F.P.M. with a maximum temperature rise of 73°F

ELEMENTS:

Element assemblies shall consist of two or three corrosion resistant steel sheathed type elements mechanically bonded to common corrosion resistant steel fins. Each sheathed element shall consist of helically coiled Nickel Chromium alloy resistant wire completely embedded in and surrounded by Magnesium Oxide, enclosed and wedged into corrosion resistant steel sheaths. Elements shall have 2" cold conductor pins extending into the sheath and shall have a density of no more than 60 Watts per inch.

THERMAL OVERLOAD:

Heaters shall be equipped with a "manual reset" thermal overload which disconnects elements and motor in the event normal operating temperatures are exceeded. For safety, if opened due to abnormal temperature, thermal overload shall remain open until manually reset. Automatic reset thermal overloads which allow the element to continue to cycle under abnormal conditions will not be accepted.

APPROVAL:

Heaters shall be ETL Listed.

OPTIONAL CONTROL SYSTEMS:

Heaters shall be operated from wall-mounted, line voltage, heavy-duty (tamper-proof) thermostats. Heaters with built-in, pre-wired contactors shall be operated from wall-mounted, line voltage, pilot duty (tamper-proof) thermostats. Heaters built with, pre-wired contactors (and control transformers) shall be operated from wall-mounted, pilot duty (24V) or (120V) wall-mounted tamper-proof thermostats. Heaters shall be controlled by integrally mounted thermostats. Thermostats shall be heavy-duty, hydraulic type with a temperature range of 40°F-120°F for double pole units and 40°F-120°F for three pole units and with remote sensing bulb placed in the return air. Thermostats shall be electrically rated at least 125% of heater rating. Thermostats shall be electrically rated at least 125% of heater rating. Thermostats shall also act as a disconnect by breaking all ungrounded conductors in the OFF position. (Thermostat control knob shall be covered by a 16 gauge tamper-proof access plate to prevent adjustment by unauthorized personnel.)

CONTACTORS:

Where required, heaters shall be equipped with heavy-duty, definite purpose contactors with flame path separators and dust covers. Contactors shall cycle all ungrounded conductors. Contactors shall have holding coils (of the same voltage as the heater) or (120 Volts) or (24 Volts).

CONTROL TRANSFORMERS:

Heater shall be equipped with a Class 2 control transformer, sealed rating of 20 VA, to supply control circuits of (24 Volts) or (120 Volts). (120 Volt secondaries not available in single phase heaters over 3 KW).

CIRCUIT BREAKERS (3450 Series Only):

Heaters shall be equipped with built-in circuit breakers in order to allow the heaters to be supplied from feeder taps. A separate switch providing a positive off for control circuits shall be included where required. Circuit breakers and control switches shall be arranged so that all line side conductors will be separately enclosed when heater front is removed for servicing so that no current carrying parts are accessible without the use of additional tools.

IDHE Duct Heater

APPLICATION & DESIGN

The IDHE series is the industry's first and only electric duct heater approved by UL for multiple mounting positions. This allows the control cabinet to be installed on either side of a horizontal duct or in any orientation on a vertical duct. The control cabinet is offset from the heating elements similar to traditional heaters. However, the IDHE affords the installer the flexibility to position the offset on the left or right as preferred. Standard features include:

- UL 1996 certified
- 50/60 Hz compatibility
- Zero clearance rating
- Hinged control cabinet cover
- Power and control terminal boards
- Automatic reset thermal safety switch for primary over temperature protection
- Heavy gauge G60 construction

PRODUCT DETAILS

Airflow Direction	Universal
Control Box Offset	Universal
Control Voltage	24 VAC
Deration	None
Element Wire	Standard
Heater Type	Slip In
Heater Voltage/Phase	208/3
Stainless Hardware	No
Power Fusing	No Preference

OPTIONS & ACCESSORIES

Airflow Switch	Non-Adjustable
Control Transformer	Unfused
Contactors	Magnetic
Disconnect Switch	Yes
Thermostat	None
Fan Interlock	No
Vapor Barrier	No
Dust Tight Box	No
Pilot Light	1
Time Delay Relay	None

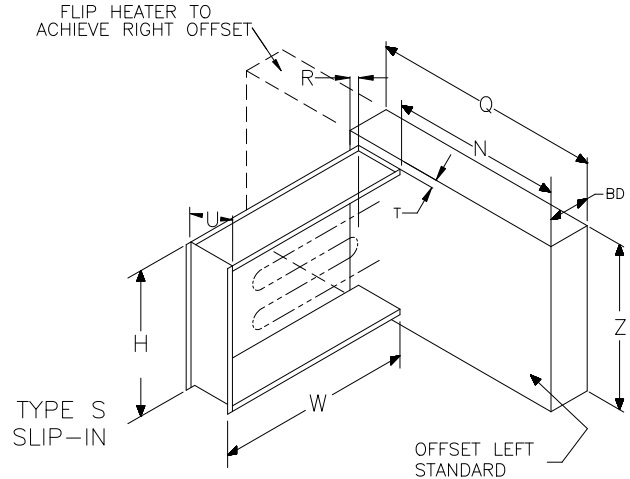

- This drawing shows a general damper configuration and is not intended to depict the exact configuration of the heater.
- All dimensions shown are in units of in.
- Individual maximum capacities are dependent on voltage/phase, control type and heater dimensions.
- Capacity: 478.8 kW maximum
- Greenheck duct heaters are universally configured to allow airflow in either direction in horizontal ducts.

ID #	TAG	QTY	WIDTH	HEIGHT	CONFIGURATION			
					Kilowatts:	Stages:	Amps:	Heater Control:
30-1		1	18.000 in.	18.000 in.	32	3	88.823	Stage:
					Power Fusing:	Dimension Q:	Dimension Z:	Dimension BD:
					Yes	32.000 in.	19.938 in.	6.250 in.
					Dimension U:	Dimension N:	Dimension R:	Dimension T:
					6.000 in.	25.000 in.	1.000 in.	1.000 in.

Minimum CFM*

Inlet Air Temp (F)	-25	0	20	40	60	70	80	100
Row ID 30-1	496	594	718	879	1125	1295	1516	2231

*Minimum air flow values are determined with uniform air volume across the face of heater coils. If air flow is not consistent across heater coils at minimum values, localized hotspots may occur and cause temperature overload to trip.

Minimum FPM*

Inlet Air Temp (F)	-25	0	20	40	60	70	80	100
Row ID 30-1	221	264	319	391	500	576	674	992

*Minimum air flow values are determined with uniform air flow across the face of heater coils. If air flow is not consistent across heater coils at minimum values, localized hotspots may occur and cause temperature overload to trip.

DIAGRAM GQ-307

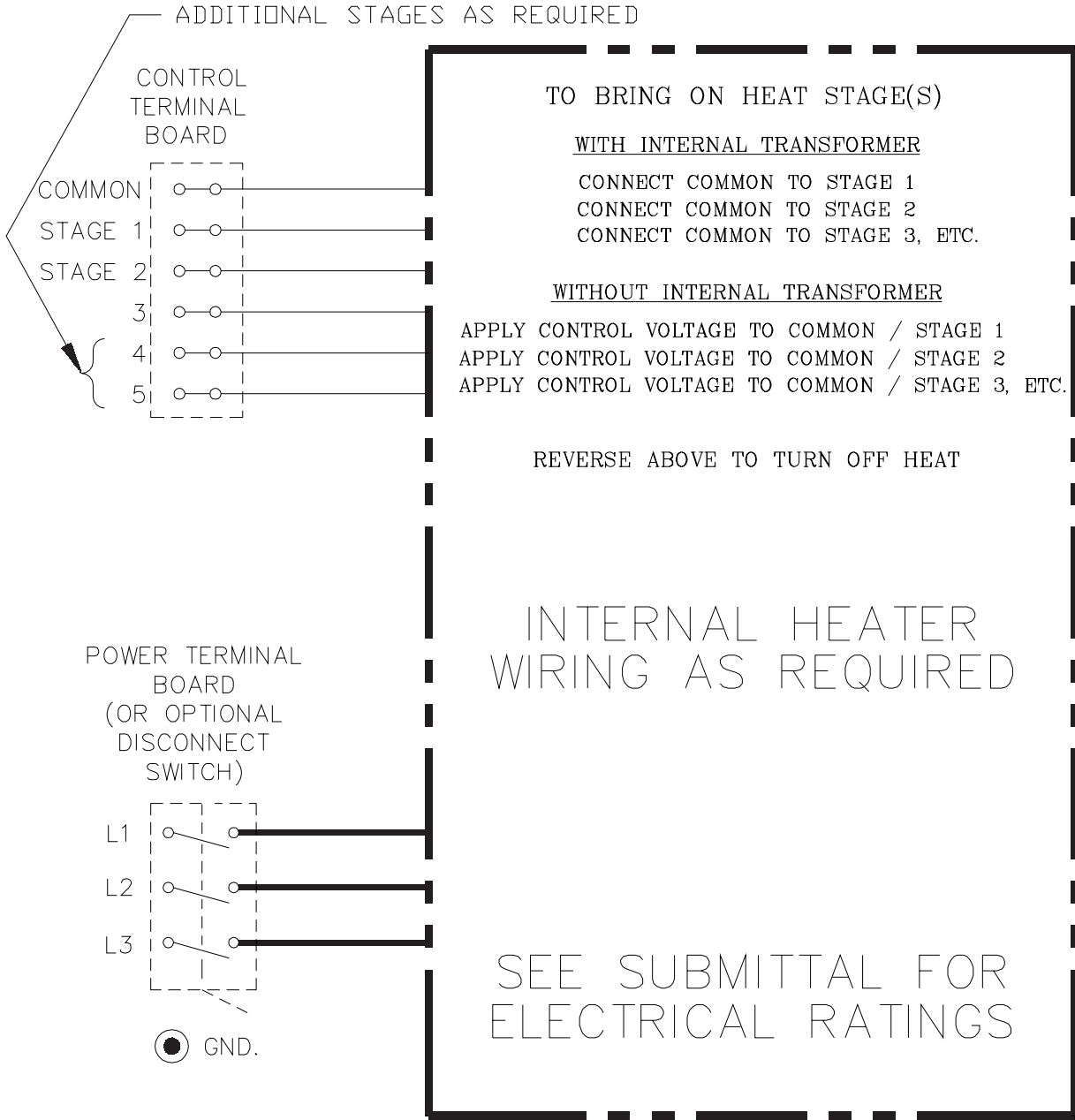

3-PHASE ELECTRICAL CONNECTIONS FOR A DUCT HEATER WITH BASIC 24VAC OR 120VAC CONTROL (3 STAGES AND ABOVE)



This print and the confidential business information which it contains are the property of Greenheck Fan Corporation of Schofield, WI. It is loaned for confidential use by recipient solely to further the business interests of Greenheck and is subject to return on request and with the mutual understanding that it will not be used in any manner detrimental to the interests of Greenheck.