

*Quality People. Building Solutions.*

Comfort Systems USA (Arkansas), Inc.  
P.O. Box 16620  
Little Rock, AR 72231  
Phone 501-834-3320  
Fax 501-834-5416

**Date:** 8/11/2023

**Return Request:** 8/22/2023

**Project:** Southside HS & JH Additions

**Supplier:** Airetech

**Manufacturer:** LG

**Submittal:** VRF HVAC Systems

**Submittal Number:** 23 81 29-01

**Drawing # and Installation:** Mechanical Drawings

**ARCHITECT**

Lewis Architects Engineers  
11225 Huron Lane, Suite 104  
Little Rock, AR 72211  
501-223-9302

**ENGINEER**

Lewis Architects Engineers  
11225 Huron Lane, Suite 104  
Little Rock, AR 72211  
501-223-9302

**GENERAL CONTRACTOR**

Nabholz  
612 Garland St.  
Conway, AR 72032  
501-505-5800

**MECHANICAL SUBCONTRACTOR**

Comfort Systems USA (Arkansas), Inc.  
9924 Landers Rd.  
N. Little Rock, AR 72117  
501-834-3320

Notes:

**CSUSA PROJECT NO.**

**23-8009**

[dpierce@comfortar.com](mailto:dpierce@comfortar.com)

9924 Landers Rd.  
No. Little Rock, AR 72117



## **SUBMITTAL DATA**

EQUIPMENT: Variable Refrigerant Flow HVAC Systems

SPEC SECTION: 23 81 29

TAGS: CU-1-1 thru 1-6 & 2-1 thru 2-3

PROJECT: Southside High School and Junior High Additions

LOCATION: Batesville, AR

ENGINEER:



CONTRACTOR:



DATE: 7/26/2023

SUBMITTED BY: Forrest Moseley  
forrest@airetechcorp.com  
501-425-6112

**DISCLAIMER:** These are some of the installation recommendations as suggested per LG Commercial Air Conditioning for proper installation of the Multi V VRF system. Proper installation is ultimately the contractor's responsibility.

- ✓ **DO NOT** use traps.
- ✓ **DO NOT** use solid core cable. Use stranded cable for data communication
- ✓ **DO NOT** use shipping caps. Braze off caps.
- ✓ **DO NOT** use field supplied cable for remote controllers. Use 30' cable provided.
- ✓ **DO NOT** splice control wiring.
- ✓ **DO NOT** open Outdoor Unit (ODU) service valves. Valves **are not** to be opened until LG commissioner is onsite.
- ✓ **DO NOT** energize ODUs, IDUs, or HR boxes during piping. Doing so will cause valves to close and prevent proper nitrogen flow.
- ✓ **DO NOT** install driers, sight glasses, solenoid valves, or any other components in the piping network. Full port ball valves are the only exception.
- ✓ **DO NOT** place ODUs where discharge air from one unit can be drawn in by another unit.
- ✓ Record all model and serial numbers
- ✓ Contractor to provide finalized near actual lengths **prior** to piping install. It is required that IDU/ODU locations and pipe routs be finalized prior to pie work to determine near actual lengths.
- ✓ Track all actual lengths and long radius 90s as you go. You will be required to produce this document at commissioning time, for proper charge calculation and warranty activation.
- ✓ **ALL** Multi V IDUs and HR boxes require **208/230/1AC Power**
- ✓ Nitrogen purge only during brazing.
- ✓ Fresh air to LG IDUs should be conditioned.
- ✓ Use only vacuum rated hoses or copper tubing for refrigerant pipe.
- ✓ It is strongly recommended that field supplied refrigerant ball valves with Schrader ports be used on both lines to **all** IDUs. Valve should be located right after Y-branch to IDU w/service port pointing towards IDU. If there are HR boxes, put valve at HR box between box and IDU.
- ✓ Allow two feet (2') for every long radius 90.
- ✓ Maintain 20" minimum of straight pipe into Y-branch from 90.
- ✓ Condensate pumps are only intended to pump condensate to a **max height of 27.5"** above the bottom of the unit up into a gravity drain. If more is required, use a third-party condensate pump. Need additional float switch for third party pump.
- ✓ If bending flex drain hose in a 90 degree upward angle, do so gradually.
- ✓ **ALL** ODUs are to be properly fastened through the provided base mounting holes. This is a condition required for warranty.
- ✓ Service valve at ODU to main line is suggested for pressure and vacuum testing.
- ✓ **Always** remove inner and outer burrs before flaring tubing.
- ✓ Ream all pipe to the full inside diameter of pipe.

## Model Selection - Summary

**Date: 07/24/2023**

### 1. Outdoor Units

No.	Model Name	Quantity	Description
1	ARUM144DTE5	3	MULTI V 5/50,60Hz/R410A/Heat Recovery/MULTI V 5/N.America
2	ARUM168DTE5	3	MULTI V 5/50,60Hz/R410A/Heat Recovery/MULTI V 5/N.America
3	ARUM241DTE5	1	MULTI V 5/50,60Hz/R410A/Heat Recovery/MULTI V 5/N.America
4	ARUM264DTE5		
4.1	ARUM168DTE5	1	MULTI V 5/50,60Hz/R410A/Heat Recovery/MULTI V 5/N.America
4.2	ARUM096DTE5	1	MULTI V 5/50,60Hz/R410A/Heat Recovery/MULTI V 5/N.America
5	ARUM312DTE5		
5.1	ARUM216DTE5	1	MULTI V 5/50,60Hz/R410A/Heat Recovery/MULTI V 5/N.America
5.2	ARUM096DTE5	1	MULTI V 5/50,60Hz/R410A/Heat Recovery/MULTI V 5/N.America
<b>Total</b>		<b>11</b>	

### 2. Indoor Units

No.	Model Name	Quantity	Description
1	ARNU093TRD4	2	CEILING CASSETTE - 4WAY
2	ARNU123TRD4	8	CEILING CASSETTE - 4WAY
3	ARNU183TQD4	20	CEILING CASSETTE - 4WAY
4	ARNU963B8A4	1	CEILING CONCEALED DUCT - HIGH STATIC(96MBH)
5	ARNU363NJA4	2	VERTICAL AHU
6	ARNU243TAA4	10	DUAL VANE CASSETTE - 4WAY
7	ARNU283TAA4	2	DUAL VANE CASSETTE - 4WAY
8	ARNU363TAA4	25	DUAL VANE CASSETTE - 4WAY
<b>Total</b>		<b>70</b>	

### 3. Branch/Header

No.	Model Name	Quantity
1	ARBLB03321	2
2	ARBLB07121	4
3	ARBLB14521	1
4	ARBLN03321	1
5	ARCNB21	2
6	PRHR023A	3
7	PRHR033A	2
8	PRHR043A	2

## Model Selection - Summary

**Date: 07/24/2023**

### 3. Branch/Header

No.	Model Name	Quantity
9	PRHR063A	7
10	PRHR083A	2

### 4. Pipes

No.	Diameter(Liq:Gas,inch)	Length(ft)
1	1/4 : 1/2	991.5
2	3/8 : 5/8	1671.0
3	3/8 : 7/8	12.0
4	3/8 : 1/2 : 5/8	165.0
5	3/8 : 5/8 : 3/4	24.0
6	3/8 : 3/4 : 7/8	101.0
7	1/2 : 7/8 : 1-1/8	236.0
8	5/8 : 1-1/8 : 1-3/8	20.0
9	5/8 : 7/8 : 1-1/8	242.0
10	3/4 : 1-1/8 : 1-3/8	225.0
11	3/4 : 1-1/8 : 1-3/8	2.0

### 5. Accessories

Model Name	Quantity	Description
PREMTBVC2	64	MultiSITE CRC2 Remote Controller (Includes Humidity)
PT-AAGW0	37	Standard Panel
PT-QCHW0	28	2x2 Grille for TR, TQ Chassis

## System Model Selection - ODU

System Name: CU1-1

**Date: 07/24/2023**

System No : 1/9

### 1. Design conditions - Outdoor

	Cooling			Heating		
	DBT(°F)	WBT(°F)	RH(%)	DBT(°F)	WBT(°F)	RH(%)
OAT	100.0	80.0	42.5	17.0	15.5	77.2
IAT	75.0	62.0	48.3	70.0	54.3	35.0

### 2. Outdoor Units

Model Name	No. of IDUs (Current / Max.) (EA)	Combination Ratio (Current / Max.) (%)	Corrected Capacity / Block Load (Cooling / Heating) (%)	Pre-charged Ref. amount (lbs)	Additional Ref. Amount (lbs)
ARUM264DTE5	11 / 42	110 / 130	0.0 / 0.0	49.70	61.16

Model Name	Combination
ARUM264DTE5	ARUM096DTE5 + ARUM168DTE5

Nominal/Corrected Capa. (kBtu/h)		Nominal/Corrected PI (kW)	
Cooling	Heating	Cooling	Heating
264.0/230.4	297.0/325.1	17.6/15.8	20.7/32.2

Efficiency(Btu/h/W)		Weight(lbs)	Dimension (WxHxD) (inch)	Electrical Characteristics				
Cooling	Heating			Volt	Phase	Hz	MCA (A)	MOP (A)
14.6	10.1	(507x1)+(639x1)	(48-13/16x66-17/32x29-29/32)x2	460	3	60	16.4+28.5	25+35

### 3. Pipes

Diameter(Liq:Gas,inch)	Length(ft)
1/4 : 1/2	147.5
3/8 : 5/8	248.0
3/8 : 7/8	12.0

### 4. Branch/Header

Model Name	Quantity
ARBLB07121	1
ARBLB14521	1
ARBLN03321	1

#Notes: Correction factor is corrected by such as, but not limited to, indoor unit combination, temperature, and pipe length.

The result can be slightly different from Product Data Book due to simulation.

Pipe lengths are estimations only.

Contractor is responsible for piping take-off and verification of actual pipe routing and pipe lengths.

## System Model Selection - ODU

System Name: CU1-1

**Date: 07/24/2023**

System No : 1/9

### 3. Pipes

Diameter(Liq:Gas,inch)	Length(ft)
3/8 : 1/2 : 5/8	40.0
3/8 : 3/4 : 7/8	80.0
1/2 : 7/8 : 1-1/8	12.0
3/4 : 1-1/8 : 1-3/8	135.0
3/4 : 1-1/8 : 1-3/8	2.0

### 4. Branch/Header

Model Name	Quantity
ARCNB21	1
PRHR023A	1
PRHR043A	1
PRHR083A	1
-	-

#Notes: Correction factor is corrected by such as, but not limited to, indoor unit combination, temperature, and pipe length.

The result can be slightly different from Product Data Book due to simulation.

Pipe lengths are estimations only.

Contractor is responsible for piping take-off and verification of actual pipe routing and pipe lengths.

## System Model Selection - ODU

System Name: CU1-1

**Date: 07/24/2023**

System No : 1/9

### 5. ODU Installation

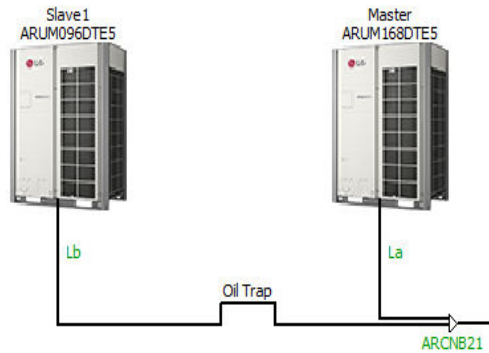

\* Oil Trap : Apply when height difference or distance between the ODUs is over 2m(6.6ft).

Outdoor Unit-Branch		
Pipe	Diameter(inch)	Length(ft)
La	5/8 : 7/8 : 1-1/8	-
Lb	3/8 : 3/4 : 7/8	-

Height Difference	
Pipe	Length(ft)
Hb (Master-Slave1)	-

#Notes: Height difference is calculated based on master ODU.

## System Model Section - IDU

System Name: CU1-1

**Date: 07/24/2023**

System No : 1/9

### 6. Indoor Units(1)

Room	Room Load(kBtu/h)			Room Design Temp.(Return Air Temp.)(°F)				Model Name	Rated TC/Corrected TC(kBtu/h)			Corrected Capa/Room Load(%)		
	TC	SC	HC	Cooling		Heating			TC	SC	HC	TC	SC	HC
				DBT	WBT	DBT	WBT							
1st Floor/Bank Fin Lab 1111	-	-	-	75.0	62.0	70.0	54.3	ARNU243TAA4	24.2/20.4	19.6/17.8	27.3/27.3	-	-	-
1st Floor/Bank Fin Lab 1111	-	-	-	75.0	62.0	70.0	54.3	ARNU243TAA4	24.2/20.4	19.6/17.8	27.3/27.3	-	-	-
1st Floor/Conference 1109	-	-	-	75.0	62.0	70.0	54.3	ARNU123TRD4	12.3/10.4	8.9/8.1	13.6/13.6	-	-	-
1st Floor/Conference 1110	-	-	-	75.0	62.0	70.0	54.3	ARNU123TRD4	12.3/10.4	8.9/8.1	13.6/13.6	-	-	-
1st Floor/Desktop Publishing Lab 1108	-	-	-	75.0	62.0	70.0	54.3	ARNU243TAA4	24.2/20.4	19.6/17.8	27.3/27.3	-	-	-
1st Floor/Desktop Publishing Lab 1114	-	-	-	75.0	62.0	70.0	54.3	ARNU243TAA4	24.2/20.4	19.6/17.8	27.3/27.3	-	-	-
1st Floor/FACS Room 1203	-	-	-	75.0	62.0	70.0	54.3	ARNU963B8A4	95.9/80.9	67.1/61.3	107.5/107.5	-	-	-
1st Floor/Instructional M.P. 1113	-	-	-	75.0	62.0	70.0	54.3	ARNU243TAA4	24.2/20.4	19.6/17.8	27.3/27.3	-	-	-
1st Floor/Lobby 1100	-	-	-	75.0	62.0	70.0	54.3	ARNU183TQD4	19.1/16.1	13.8/12.5	21.5/21.5	-	-	-
1st Floor/Locker Room 1336	-	-	-	75.0	62.0	70.0	54.3	ARNU243TAA4	24.2/20.4	19.6/17.8	27.3/27.3	-	-	-
1st Floor/Office 1204	-	-	-	75.0	62.0	70.0	54.3	ARNU093TRD4	9.6/8.1	6.9/6.3	10.9/10.9	-	-	-

#Notes: Correction factor is corrected by such as, but not limited to, indoor unit combination, temperature, and pipe length.

The result can be slightly different from Product Data Book due to simulation.

Pipe lengths are estimations only.

Contractor is responsible for piping take-off and verification of actual pipe routing and pipe lengths.

EWT=Entering Water Temperature / LWT=Leaving Water Temperature.

## System Model Section - IDU

System Name: CU1-1

**Date: 07/24/2023**

System No : 1/9

### 7. Indoor Units(2)

Tag	Model Name	Type	Est. Discharge Temp.(°F)		Air flow rate (CFM)	Remark
			Cooling	Heating		
FC1-2	ARNU243TAA4	DUALVANE CST 4WAY	55.6	100.1	813.0	NA
FC1-1	ARNU243TAA4	DUALVANE CST 4WAY	55.6	100.1	813.0	NA
FC1-3	ARNU123TRD4	CASSETTE 4WAY	51.8	109.7	307.3	NA
FC1-4	ARNU123TRD4	CASSETTE 4WAY	51.8	109.7	307.3	NA
FC1-7	ARNU243TAA4	DUALVANE CST 4WAY	55.6	100.1	813.0	NA
FC1-6	ARNU243TAA4	DUALVANE CST 4WAY	55.6	100.1	813.0	NA
FC1-11	ARNU963B8A4	DUCT HIGH STATIC	53.7	107.9	2542.0	Setting Value: 105 / E.S.P: 0.8700 inchAq
FC1-8	ARNU243TAA4	DUALVANE CST 4WAY	55.6	100.1	813.0	NA
FC1-5	ARNU183TQD4	CASSETTE 4WAY	47.0	118.7	395.5	NA
FC1-23	ARNU243TAA4	DUALVANE CST 4WAY	55.6	100.1	813.0	NA
FC1-10	ARNU093TRD4	CASSETTE 4WAY	55.3	104.5	283.0	NA

#Notes: Correction factor is corrected by such as, but not limited to, indoor unit combination, temperature, and pipe length.

The result can be slightly different from Product Data Book due to simulation.

Pipe lengths are estimations only.

Contractor is responsible for piping take-off and verification of actual pipe routing and pipe lengths.

EWT=Entering Water Temperature / LWT=Leaving Water Temperature.

## System Model Section - IDU

System Name: CU1-1

**Date: 07/24/2023**

System No : 1/9

### 8. Indoor Units(3)

Tag	Model Name	Weight	Dimension (WxHxD)	Electrical Characteristics				
				Volt	Phase	Hz	MCA (A)	RLA (A)
FC1-2	ARNU243TAA4	59.5 lbs	33-1/16x11-11/32x33-1/16 inch	208~230	1	60	2.09	1.67
FC1-1	ARNU243TAA4	59.5 lbs	33-1/16x11-11/32x33-1/16 inch	208~230	1	60	2.09	1.67
FC1-3	ARNU123TRD4	32 lbs	22-7/16x8-7/16x22-7/16 inch	208~230	1	60	0.25	0.2
FC1-4	ARNU123TRD4	32 lbs	22-7/16x8-7/16x22-7/16 inch	208~230	1	60	0.25	0.2
FC1-7	ARNU243TAA4	59.5 lbs	33-1/16x11-11/32x33-1/16 inch	208~230	1	60	2.09	1.67
FC1-6	ARNU243TAA4	59.5 lbs	33-1/16x11-11/32x33-1/16 inch	208~230	1	60	2.09	1.67
FC1-11	ARNU963B8A4	192 lbs	61-1/2x18-1/8x27-1/8 inch	208~230	1	60	6.50	5.2
FC1-8	ARNU243TAA4	59.5 lbs	33-1/16x11-11/32x33-1/16 inch	208~230	1	60	2.09	1.67
FC1-5	ARNU183TQD4	35 lbs	22-7/16x10x22-7/16 inch	208~230	1	60	0.25	0.2
FC1-23	ARNU243TAA4	59.5 lbs	33-1/16x11-11/32x33-1/16 inch	208~230	1	60	2.09	1.67
FC1-10	ARNU093TRD4	32 lbs	22-7/16x8-7/16x22-7/16 inch	208~230	1	60	0.25	0.2

#Notes: Correction factor is corrected by such as, but not limited to, indoor unit combination, temperature, and pipe length.

The result can be slightly different from Product Data Book due to simulation.

Pipe lengths are estimations only.

Contractor is responsible for piping take-off and verification of actual pipe routing and pipe lengths.

EWT=Entering Water Temperature / LWT=Leaving Water Temperature.

## System Validation Check

System Name: CU1-1

**Date: 07/24/2023**

System No : 1/9

### 9. System Validation Check - General Condition

Contents	Limit	Current(Max value : connected unit)
Total pipe length	3280.8 ft	676.5 ft
Longest equivalent pipe length	574.1 ft	246.0 ft : ARNU093TRD4[FC1-10]
Longest pipe length after 1st branch	131.2 ft	99.5 ft : ARNU093TRD4[FC1-10]
Height difference [Above: IDU, Below: ODU]	360.9 ft	0.0 ft
Height difference [Above: ODU, Below: IDU]	360.9 ft	20.0 ft : ARNU093TRD4[FC1-10]
Height difference [IDU to IDU]	131.2 ft	0.0 ft : ARNU243TAA4[FC1-23]-ARNU243TAA4[FC1-23]
Longest actual pipe length	492.1 ft	234.5 ft : ARNU093TRD4[FC1-10]
Height difference [HRU to HRU]	98.4 ft	0.0 ft
Height difference [HRU to HRU connected in series (same branch)]	16.4 ft	0.0 ft
Height difference [HRU to IDU]	49.2 ft	0.0 ft

Note 1 : Except "Longest equivalent pipe length", the other pipe length limitations are actual length.

# System Tree Diagram

System Name: CU1-1

Date: **07/24/2023**

System No : 1/9

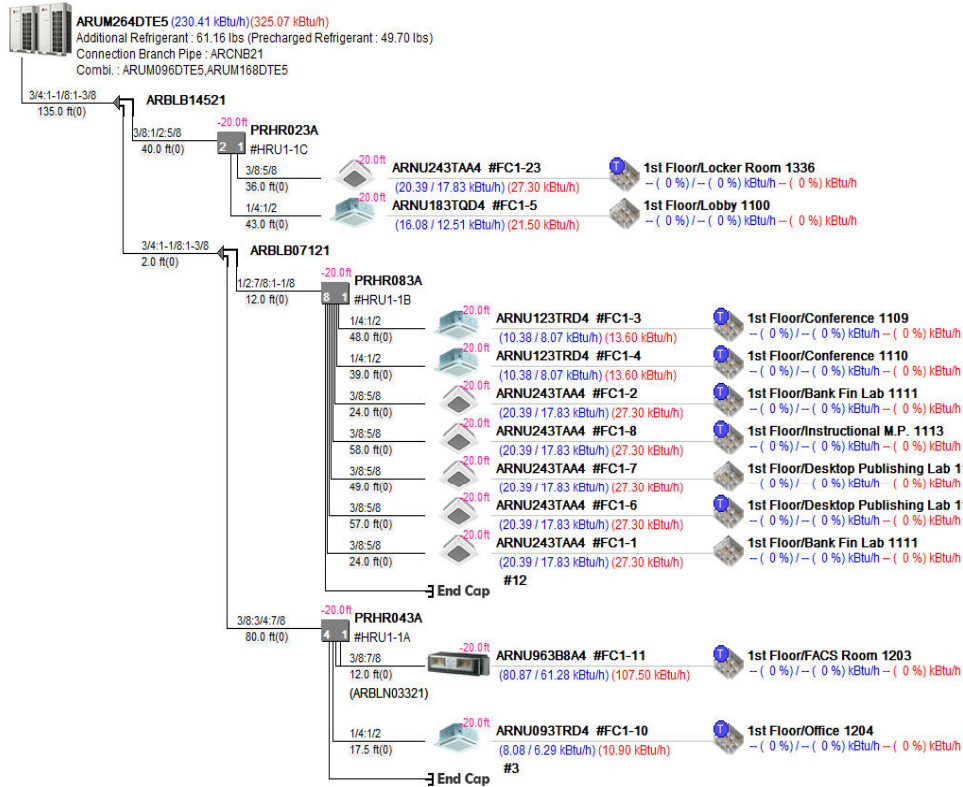

\* : Main pipe upsized  
 \*\* : Conditional Application  
**Three pipe** : Liquid : High Gas : Low Gas  
**Two pipe** : Liquid : Gas

ⓘ Thermostat, Ⓜ Group Control, Ⓞ Dry Contact, Ⓢ EEV Kit for Multi V Indoor  
 Ⓢ AHU Comm. Kit [Discharge (supply) air], Ⓡ AHU Comm. Kit [Return air]  
 Ⓜ AHU Comm. Kit [Main module], Ⓢ AHU Comm. Kit [Communications module]

Indoor Units	: 11 of 42
Combination Ratio	: 291.0 of 264.0 (110%)
Total Pipe	: 676.5 of 3280.8 ft
ODU factory charge	: 49.70 lbs
Additional Refrigerant	: 61.16 lbs
Total refrigerant	: 110.86 lbs
Minimum room volume	: 4264.00 ft³
(Based on 26.0 lbs / 1000.0 ft³)	

# System Schematic Diagram

System Name: CU1-1

**Date: 07/24/2023**

System No : 1/9

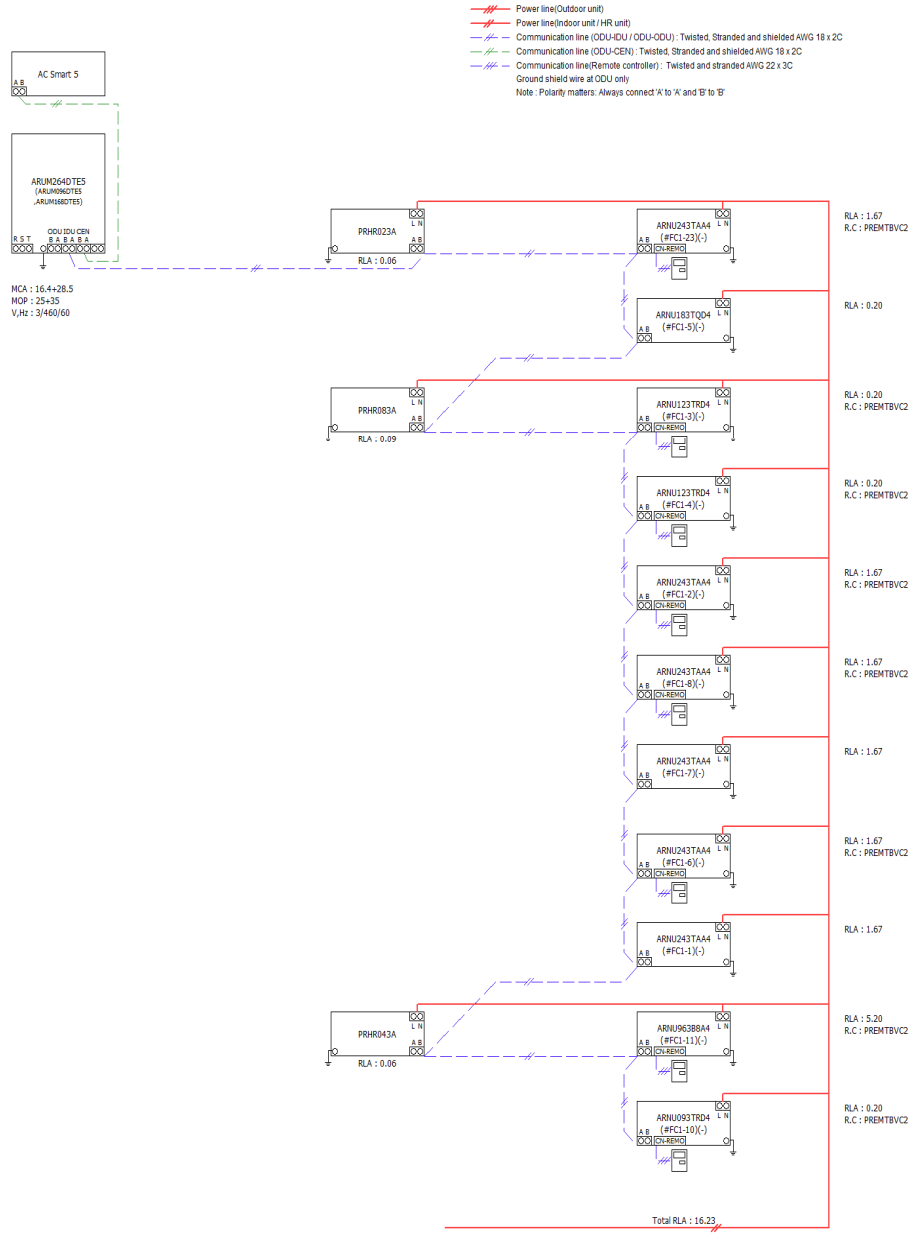

# Note :  
 Power wiring, breaker size, and disconnects should follow local code and NEC.  
 Multi-frame outdoor units require a separate power connection for each frame.  
 Refer to the most up-to-date submittal sheets for applicable electrical data.

## System Model Selection - ODU

System Name: CU1-2

**Date: 07/24/2023**

System No : 2/9

### 1. Design conditions - Outdoor

	Cooling			Heating		
	DBT(°F)	WBT(°F)	RH(%)	DBT(°F)	WBT(°F)	RH(%)
OAT	100.0	80.0	42.5	17.0	15.5	77.2
IAT	75.0	62.0	48.3	70.0	54.3	35.0

### 2. Outdoor Units

Model Name	No. of IDUs (Current / Max.) (EA)	Combination Ratio (Current / Max.) (%)	Corrected Capacity / Block Load (Cooling / Heating) (%)	Pre-charged Ref. amount (lbs)	Additional Ref. Amount (lbs)
ARUM168DTE5	8 / 29	107 / 130	0.0 / 0.0	26.50	26.68

Nominal/Corrected Capa. (kBtu/h)		Nominal/Corrected PI (kW)	
Cooling	Heating	Cooling	Heating
168.0/147.5	189.0/201.5	12.2/10.8	14.0/21.6

Efficiency(Btu/h/W)		Weight(lbs)	Dimension (WxHxD) (inch)	Electrical Characteristics				
Cooling	Heating			Volt	Phase	Hz	MCA (A)	MOP (A)
13.6	9.3	639x1	48-13/16x66-17/32x29-29/32	460	3	60	28.4	35

### 3. Pipes

Diameter(Liq:Gas,inch)	Length(ft)
1/4 : 1/2	104.0
3/8 : 5/8	125.0
3/8 : 1/2 : 5/8	93.0
3/8 : 5/8 : 3/4	24.0
1/2 : 7/8 : 1-1/8	7.0
5/8 : 7/8 : 1-1/8	30.0

### 4. Branch/Header

Model Name	Quantity
ARBLB03321	1
ARBLB07121	1
PRHR023A	1
PRHR033A	2
-	-
-	-

#Notes: Correction factor is corrected by such as, but not limited to, indoor unit combination, temperature, and pipe length.

The result can be slightly different from Product Data Book due to simulation.

Pipe lengths are estimations only.

Contractor is responsible for piping take-off and verification of actual pipe routing and pipe lengths.

## System Model Section - IDU

System Name: CU1-2

**Date: 07/24/2023**

System No : 2/9

### 5. Indoor Units(1)

Room	Room Load(kBtu/h)			Room Design Temp.(Return Air Temp.)(°F)				Model Name	Rated TC/Corrected TC(kBtu/h)			Corrected Capa/Room Load(%)		
	TC	SC	HC	Cooling		Heating			TC	SC	HC	TC	SC	HC
				DBT	WBT	DBT	WBT							
1st Floor/AD Off 1427	-	-	-	75.0	62.0	70.0	54.3	ARNU123TRD4	12.3/10.4	8.9/8.1	13.6/13.6	-	-	-
1st Floor/Corridor 1429	-	-	-	75.0	62.0	70.0	54.3	ARNU183TQD4	19.1/16.1	13.8/12.5	21.5/21.5	-	-	-
1st Floor/FCS Classroom 1423	-	-	-	75.0	62.0	70.0	54.3	ARNU363TAA4	36.2/30.5	26.8/24.4	40.6/40.6	-	-	-
1st Floor/Food Production Lab 1202	-	-	-	75.0	62.0	70.0	54.3	ARNU363TAA4	36.2/30.5	26.8/24.4	40.6/40.6	-	-	-
1st Floor/Lobby 1210	-	-	-	75.0	62.0	70.0	54.3	ARNU183TQD4	19.1/16.1	13.8/12.5	21.5/21.5	-	-	-
1st Floor/Locker RM 1424	-	-	-	75.0	62.0	70.0	54.3	ARNU243TAA4	24.2/20.4	19.6/17.8	27.3/27.3	-	-	-
1st Floor/Speech 1211	-	-	-	75.0	62.0	70.0	54.3	ARNU183TQD4	19.1/16.1	13.8/12.5	21.5/21.5	-	-	-
1st Floor/Speech 1212	-	-	-	75.0	62.0	70.0	54.3	ARNU183TQD4	19.1/16.1	13.8/12.5	21.5/21.5	-	-	-

#Notes: Correction factor is corrected by such as, but not limited to, indoor unit combination, temperature, and pipe length.

The result can be slightly different from Product Data Book due to simulation.

Pipe lengths are estimations only.

Contractor is responsible for piping take-off and verification of actual pipe routing and pipe lengths.

EWT=Entering Water Temperature / LWT=Leaving Water Temperature.

## System Model Section - IDU

System Name: CU1-2

**Date: 07/24/2023**

System No : 2/9

### 6. Indoor Units(2)

Tag	Model Name	Type	Est. Discharge Temp.(°F)		Air flow rate (CFM)	Remark
			Cooling	Heating		
FC1-31	ARNU123TRD4	CASSETTE 4WAY	51.8	109.7	307.3	NA
FC1-33	ARNU183TQD4	CASSETTE 4WAY	47.0	118.7	395.5	NA
FC1-32	ARNU363TAA4	DUALVANE CST 4WAY	53.2	106.9	988.0	NA
FC1-12	ARNU363TAA4	DUALVANE CST 4WAY	53.2	106.9	988.0	NA
FC1-15	ARNU183TQD4	CASSETTE 4WAY	47.0	118.7	395.5	NA
FC1-30	ARNU243TAA4	DUALVANE CST 4WAY	55.6	100.1	813.0	NA
FC1-13	ARNU183TQD4	CASSETTE 4WAY	47.0	118.7	395.5	NA
FC1-14	ARNU183TQD4	CASSETTE 4WAY	47.0	118.7	395.5	NA

#Notes: Correction factor is corrected by such as, but not limited to, indoor unit combination, temperature, and pipe length.

The result can be slightly different from Product Data Book due to simulation.

Pipe lengths are estimations only.

Contractor is responsible for piping take-off and verification of actual pipe routing and pipe lengths.

EWT=Entering Water Temperature / LWT=Leaving Water Temperature.

## System Model Section - IDU

System Name: CU1-2

**Date: 07/24/2023**

System No : 2/9

### 7. Indoor Units(3)

Tag	Model Name	Weight	Dimension (WxHxD)	Electrical Characteristics				
				Volt	Phase	Hz	MCA (A)	RLA (A)
FC1-31	ARNU123TRD4	32 lbs	22-7/16x8-7/16x22-7/16 inch	208~230	1	60	0.25	0.2
FC1-33	ARNU183TQD4	35 lbs	22-7/16x10x22-7/16 inch	208~230	1	60	0.25	0.2
FC1-32	ARNU363TAA4	59.5 lbs	33-1/16x11-11/32x33-1/16 inch	208~230	1	60	2.09	1.67
FC1-12	ARNU363TAA4	59.5 lbs	33-1/16x11-11/32x33-1/16 inch	208~230	1	60	2.09	1.67
FC1-15	ARNU183TQD4	35 lbs	22-7/16x10x22-7/16 inch	208~230	1	60	0.25	0.2
FC1-30	ARNU243TAA4	59.5 lbs	33-1/16x11-11/32x33-1/16 inch	208~230	1	60	2.09	1.67
FC1-13	ARNU183TQD4	35 lbs	22-7/16x10x22-7/16 inch	208~230	1	60	0.25	0.2
FC1-14	ARNU183TQD4	35 lbs	22-7/16x10x22-7/16 inch	208~230	1	60	0.25	0.2

#Notes: Correction factor is corrected by such as, but not limited to, indoor unit combination, temperature, and pipe length.

The result can be slightly different from Product Data Book due to simulation.

Pipe lengths are estimations only.

Contractor is responsible for piping take-off and verification of actual pipe routing and pipe lengths.

EWT=Entering Water Temperature / LWT=Leaving Water Temperature.

## System Validation Check

System Name: CU1-2

**Date: 07/24/2023**

System No : 2/9

### 8. System Validation Check - General Condition

Contents	Limit	Current(Max value : connected unit)
Total pipe length	3280.8 ft	383.0 ft
Longest equivalent pipe length	574.1 ft	132.5 ft : ARNU363TAA4[FC1-12]
Longest pipe length after 1st branch	131.2 ft	91.0 ft : ARNU363TAA4[FC1-12]
Height difference [Above: IDU, Below: ODU]	360.9 ft	0.0 ft
Height difference [Above: ODU, Below: IDU]	360.9 ft	20.0 ft : ARNU123TRD4[FC1-31]
Height difference [IDU to IDU]	131.2 ft	0.0 ft : ARNU183TQD4[FC1-13]-ARNU183TQD4[FC1-13]
Longest actual pipe length	492.1 ft	121.0 ft : ARNU363TAA4[FC1-12]
Height difference [HRU to HRU]	98.4 ft	0.0 ft
Height difference [HRU to HRU connected in series (same branch)]	16.4 ft	0.0 ft
Height difference [HRU to IDU]	49.2 ft	0.0 ft

Note 1 : Except "Longest equivalent pipe length", the other pipe length limitations are actual length.

# System Tree Diagram

System Name: CU1-2

**Date: 07/24/2023**

System No : 2/9

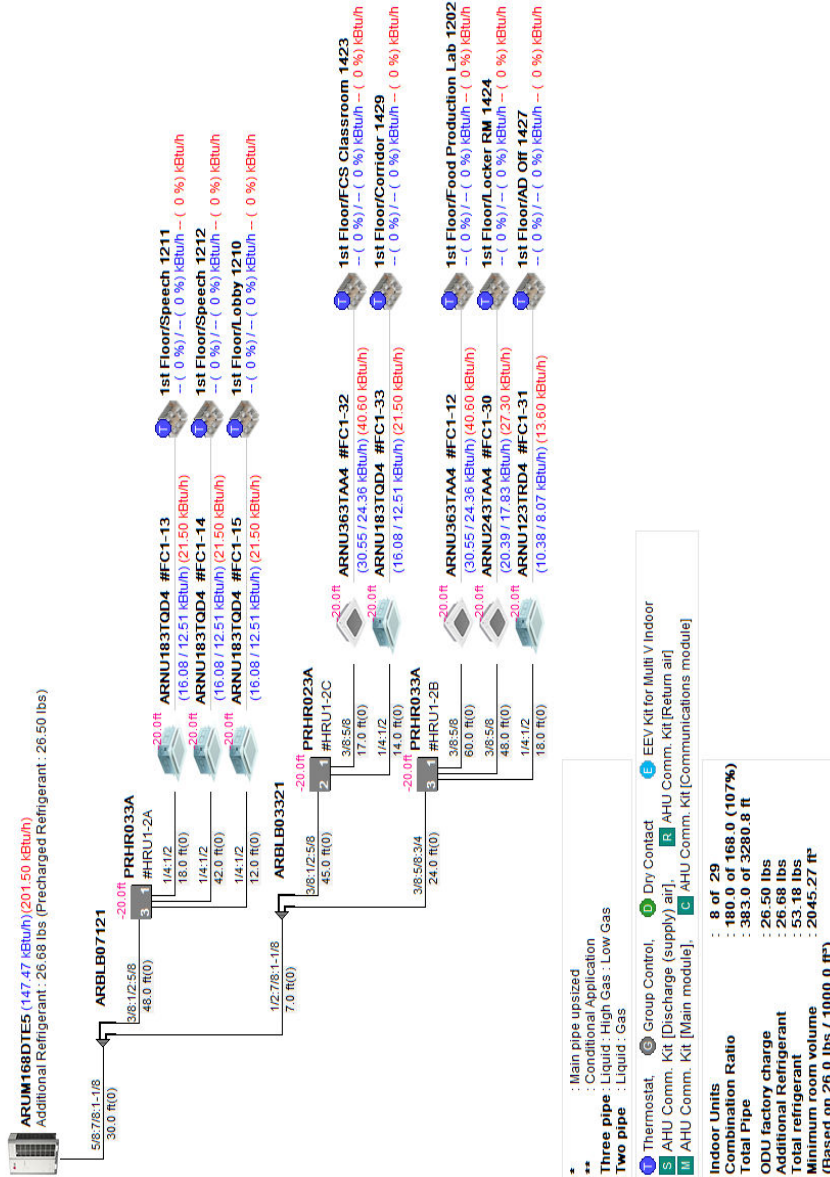

# System Schematic Diagram

System Name: CU1-2

**Date: 07/24/2023**

System No : 2/9

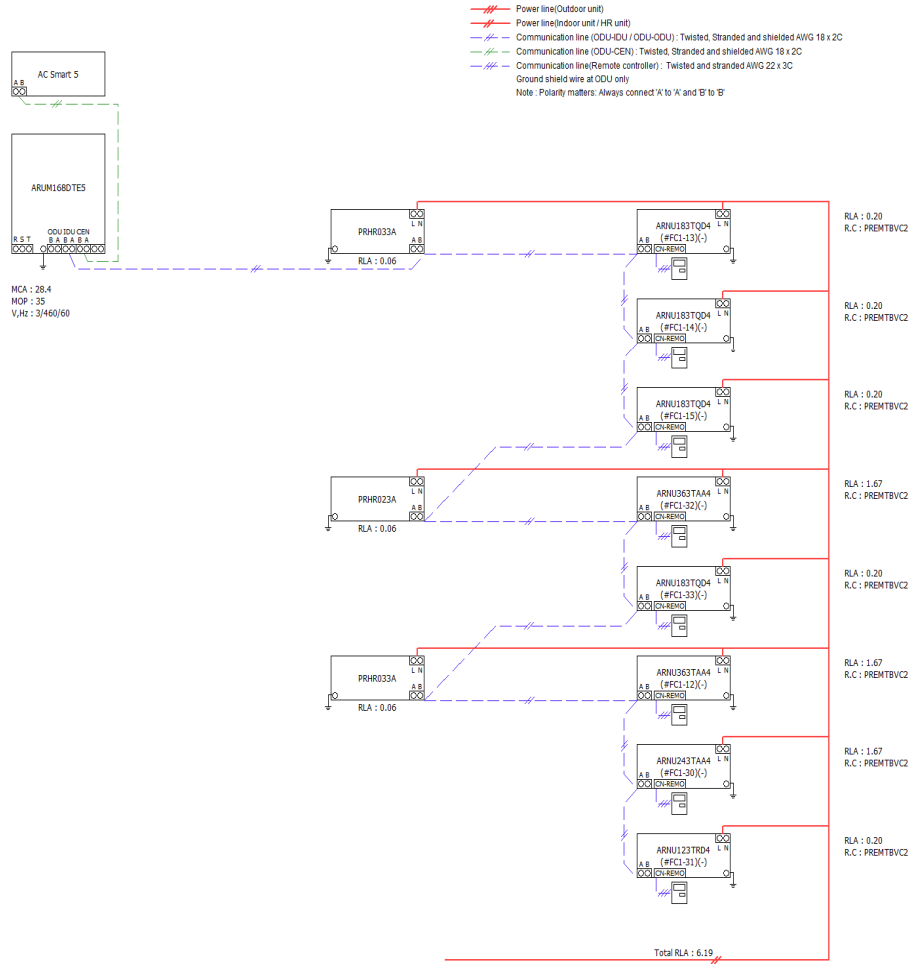

# Note :  
 Power wiring, breaker size, and disconnects should follow local code and NEC.  
 Multi-frame outdoor units require a separate power connection for each frame.  
 Refer to the most up-to-date submittal sheets for applicable electrical data.

## System Model Selection - ODU

System Name: CU1-3

**Date: 07/24/2023**

System No : 3/9

### 1. Design conditions - Outdoor

	Cooling			Heating		
	DBT(°F)	WBT(°F)	RH(%)	DBT(°F)	WBT(°F)	RH(%)
OAT	100.0	80.0	42.5	17.0	15.5	77.2
IAT	75.0	62.0	48.3	70.0	54.3	35.0

### 2. Outdoor Units

Model Name	No. of IDUs (Current / Max.) (EA)	Combination Ratio (Current / Max.) (%)	Corrected Capacity / Block Load (Cooling / Heating) (%)	Pre-charged Ref. amount (lbs)	Additional Ref. Amount (lbs)
ARUM168DTE5	7 / 29	104 / 130	0.0 / 0.0	26.50	25.49

Nominal/Corrected Capa. (kBtu/h)		Nominal/Corrected PI (kW)	
Cooling	Heating	Cooling	Heating
168.0/141.0	189.0/195.2	12.2/10.6	14.0/21.4

Efficiency(Btu/h/W)		Weight(lbs)	Dimension (WxHxD) (inch)	Electrical Characteristics				
Cooling	Heating			Volt	Phase	Hz	MCA (A)	MOP (A)
13.3	9.1	639x1	48-13/16x66-17/32x29-29/32	460	3	60	28.4	35

### 3. Pipes

Diameter(Liq:Gas,inch)	Length(ft)
1/4 : 1/2	139.0
3/8 : 5/8	143.0
5/8 : 7/8 : 1-1/8	70.0

### 4. Branch/Header

Model Name	Quantity
PRHR083A	1
-	-
-	-

#Notes: Correction factor is corrected by such as, but not limited to, indoor unit combination, temperature, and pipe length.

The result can be slightly different from Product Data Book due to simulation.

Pipe lengths are estimations only.

Contractor is responsible for piping take-off and verification of actual pipe routing and pipe lengths.

## System Model Section - IDU

System Name: CU1-3

**Date: 07/24/2023**

System No : 3/9

### 5. Indoor Units(1)

Room	Room Load(kBtu/h)			Room Design Temp.(Return Air Temp.)(°F)				Model Name	Rated TC/Corrected TC(kBtu/h)			Corrected Capa/Room Load(%)		
	TC	SC	HC	Cooling		Heating			TC	SC	HC	TC	SC	HC
				DBT	WBT	DBT	WBT							
1st Floor/Corridor 1304	-	-	-	75.0	62.0	70.0	54.3	ARNU363NJA4	36.0/30.4	25.9/23.7	40.0/40.0	-	-	-
1st Floor/Health Classroom 1321	-	-	-	75.0	62.0	70.0	54.3	ARNU363TAA4	36.2/30.5	26.8/24.4	40.6/40.6	-	-	-
1st Floor/Health Classroom 1321	-	-	-	75.0	62.0	70.0	54.3	ARNU363TAA4	36.2/30.5	26.8/24.4	40.6/40.6	-	-	-
1st Floor/Locker Rm 1322	-	-	-	75.0	62.0	70.0	54.3	ARNU183TQD4	19.1/16.1	13.8/12.5	21.5/21.5	-	-	-
1st Floor/Locker Rm 1324	-	-	-	75.0	62.0	70.0	54.3	ARNU183TQD4	19.1/16.1	13.8/12.5	21.5/21.5	-	-	-
1st Floor/Locker Room 1334	-	-	-	75.0	62.0	70.0	54.3	ARNU183TQD4	19.1/16.1	13.8/12.5	21.5/21.5	-	-	-
1st Floor/Office 1332	-	-	-	75.0	62.0	70.0	54.3	ARNU123TRD4	12.3/10.4	8.9/8.1	13.6/13.6	-	-	-

#Notes: Correction factor is corrected by such as, but not limited to, indoor unit combination, temperature, and pipe length.

The result can be slightly different from Product Data Book due to simulation.

Pipe lengths are estimations only.

Contractor is responsible for piping take-off and verification of actual pipe routing and pipe lengths.

EWT=Entering Water Temperature / LWT=Leaving Water Temperature.

## System Model Section - IDU

System Name: CU1-3

**Date: 07/24/2023**

System No : 3/9

### 6. Indoor Units(2)

Tag	Model Name	Type	Est. Discharge Temp.(°F)		Air flow rate (CFM)	Remark
			Cooling	Heating		
FC1-18	ARNU363NJA4	VERTICAL AHU	53.8	106.3	988.9	Setting Value: 95 / E.S.P: 0.4015 inchAq
FC1-21	ARNU363TAA4	DUALVANE CST 4WAY	53.2	106.9	988.0	NA
FC1-22	ARNU363TAA4	DUALVANE CST 4WAY	53.2	106.9	988.0	NA
FC1-17	ARNU183TQD4	CASSETTE 4WAY	47.0	118.7	395.5	NA
FC1-16	ARNU183TQD4	CASSETTE 4WAY	47.0	118.7	395.5	NA
FC1-19	ARNU183TQD4	CASSETTE 4WAY	47.0	118.7	395.5	NA
FC1-20	ARNU123TRD4	CASSETTE 4WAY	51.8	109.7	307.3	NA

#Notes: Correction factor is corrected by such as, but not limited to, indoor unit combination, temperature, and pipe length.

The result can be slightly different from Product Data Book due to simulation.

Pipe lengths are estimations only.

Contractor is responsible for piping take-off and verification of actual pipe routing and pipe lengths.

EWT=Entering Water Temperature / LWT=Leaving Water Temperature.

## System Model Section - IDU

System Name: CU1-3

**Date: 07/24/2023**

System No : 3/9

### 7. Indoor Units(3)

Tag	Model Name	Weight	Dimension (WxHxD)	Electrical Characteristics				
				Volt	Phase	Hz	MCA (A)	RLA (A)
FC1-18	ARNU363NJA4	121 lbs	18x48-11/16x21-1/4 inch	208~230	1	60	1.40	1.12
FC1-21	ARNU363TAA4	59.5 lbs	33-1/16x11-11/32x33-1/16 inch	208~230	1	60	2.09	1.67
FC1-22	ARNU363TAA4	59.5 lbs	33-1/16x11-11/32x33-1/16 inch	208~230	1	60	2.09	1.67
FC1-17	ARNU183TQD4	35 lbs	22-7/16x10x22-7/16 inch	208~230	1	60	0.25	0.2
FC1-16	ARNU183TQD4	35 lbs	22-7/16x10x22-7/16 inch	208~230	1	60	0.25	0.2
FC1-19	ARNU183TQD4	35 lbs	22-7/16x10x22-7/16 inch	208~230	1	60	0.25	0.2
FC1-20	ARNU123TRD4	32 lbs	22-7/16x8-7/16x22-7/16 inch	208~230	1	60	0.25	0.2

#Notes: Correction factor is corrected by such as, but not limited to, indoor unit combination, temperature, and pipe length.

The result can be slightly different from Product Data Book due to simulation.

Pipe lengths are estimations only.

Contractor is responsible for piping take-off and verification of actual pipe routing and pipe lengths.

EWT=Entering Water Temperature / LWT=Leaving Water Temperature.

## System Validation Check

System Name: CU1-3

**Date: 07/24/2023**

System No : 3/9

### 8. System Validation Check - General Condition

Contents	Limit	Current(Max value : connected unit)
Total pipe length	3280.8 ft	352.0 ft
Longest equivalent pipe length	574.1 ft	154.2 ft : ARNU363TAA4[FC1-22]
Longest pipe length after 1st branch	131.2 ft	76.0 ft : ARNU363TAA4[FC1-22]
Height difference [Above: IDU, Below: ODU]	360.9 ft	0.0 ft
Height difference [Above: ODU, Below: IDU]	360.9 ft	20.0 ft : ARNU183TQD4[FC1-16]
Height difference [IDU to IDU]	131.2 ft	0.0 ft : ARNU183TQD4[FC1-19]-ARNU183TQD4[FC1-19]
Longest actual pipe length	492.1 ft	146.0 ft : ARNU363TAA4[FC1-22]
Height difference [HRU to HRU]	98.4 ft	0.0 ft
Height difference [HRU to HRU connected in series (same branch)]	16.4 ft	0.0 ft
Height difference [HRU to IDU]	49.2 ft	0.0 ft

Note 1 : Except "Longest equivalent pipe length", the other pipe length limitations are actual length.

# System Tree Diagram

System Name: CU1-3

Date: 07/24/2023

System No : 3/9

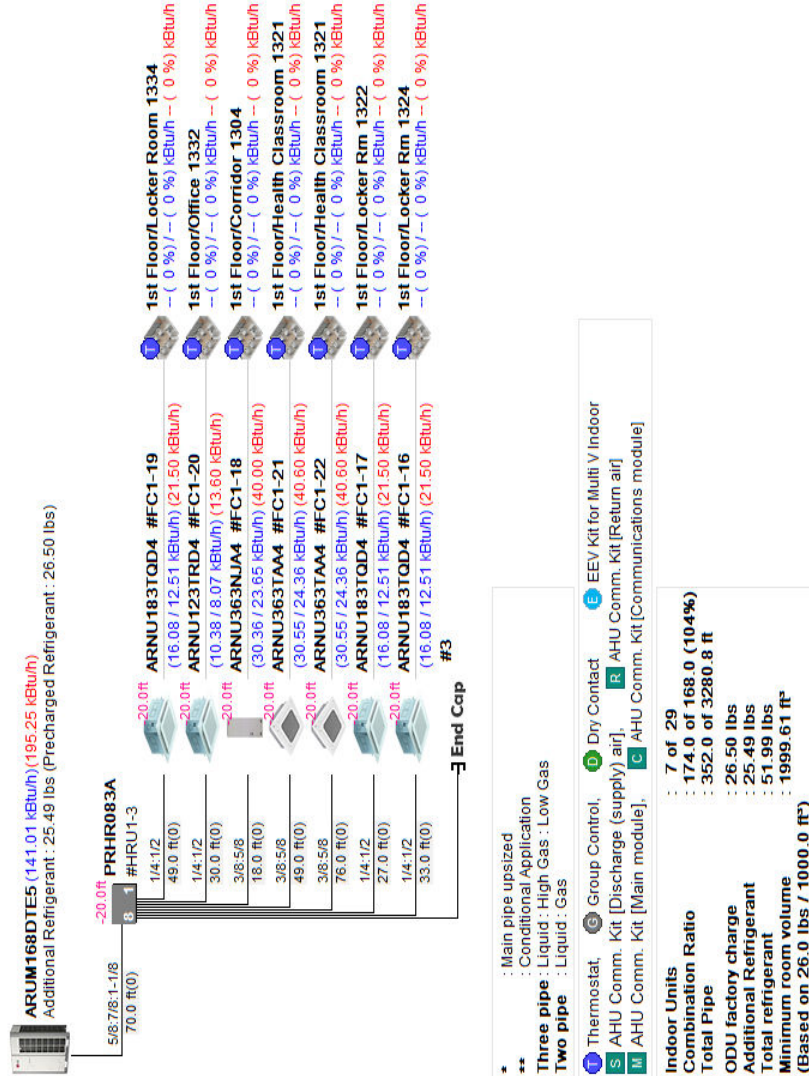







# System Schematic Diagram

System Name: CU1-3

**Date: 07/24/2023**

System No : 3/9

-  Power line(Outdoor unit)
  -  Power line(Indoor unit / HR unit)
  -  Communication line (ODU-ODU / ODU-ODU) : Twisted, Stranded and shielded AWG 18 x 2C
  -  Communication line (ODU-CEN) : Twisted, Stranded and shielded AWG 18 x 2C
  -  Grounding shield wire at ODU (Central controller) : Twisted and Stranded AWG 22 x 3C
  -  Grounding shield wire at ODU (Indoor unit)
- Note : Polarity matters. Always connect 'A' to 'A' and 'B' to 'B'

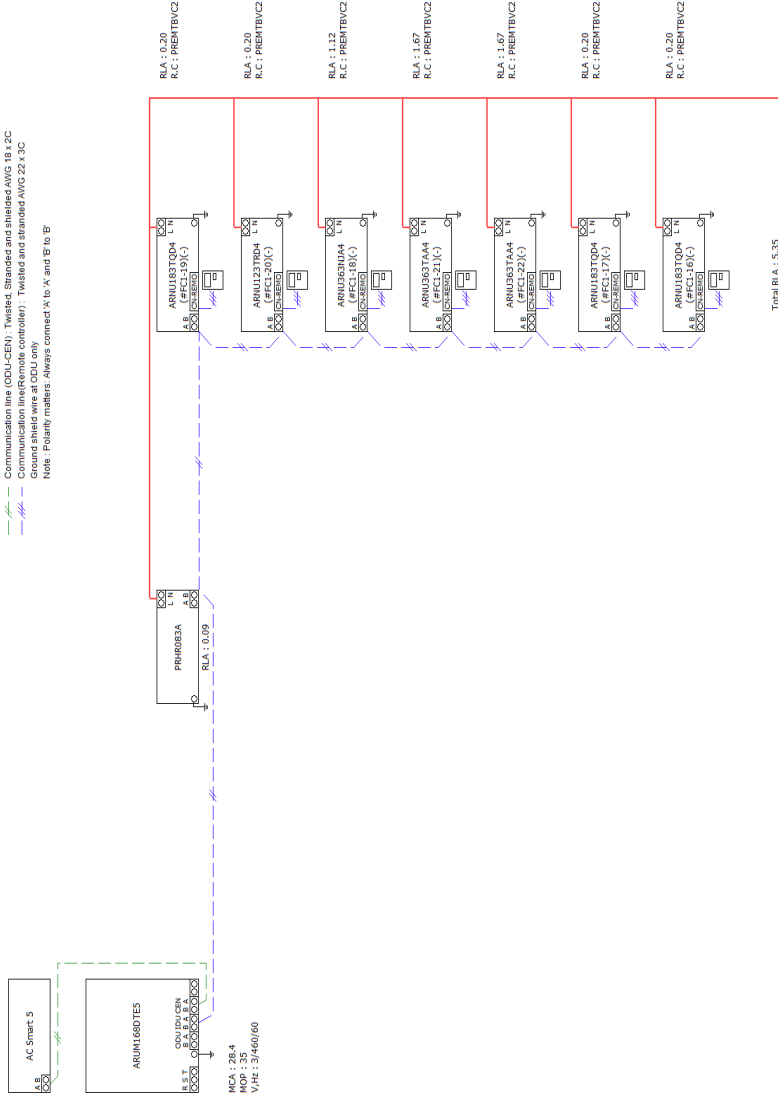

# Note :  
Power wiring, breaker size, and disconnects should follow local code and NEC.  
Multi-frame outdoor units require a separate power connection for each frame.  
Refer to the most up-to-date submittal sheets for applicable electrical data.

## System Model Selection - ODU

System Name: CU1-4

**Date: 07/24/2023**

System No : 4/9

### 1. Design conditions - Outdoor

	Cooling			Heating		
	DBT(°F)	WBT(°F)	RH(%)	DBT(°F)	WBT(°F)	RH(%)
OAT	100.0	80.0	42.5	17.0	15.5	77.2
IAT	75.0	62.0	48.3	70.0	54.3	35.0

### 2. Outdoor Units

Model Name	No. of IDUs (Current / Max.) (EA)	Combination Ratio (Current / Max.) (%)	Corrected Capacity / Block Load (Cooling / Heating) (%)	Pre-charged Ref. amount (lbs)	Additional Ref. Amount (lbs)
ARUM144DTE5	6 / 24	100 / 130	0.0 / 0.0	26.50	19.25

Nominal/Corrected Capa. (kBtu/h)		Nominal/Corrected PI (kW)	
Cooling	Heating	Cooling	Heating
144.0/117.3	162.0/162.0	9.3/7.9	10.5/16.0

Efficiency(Btu/h/W)		Weight(lbs)	Dimension (WxHxD) (inch)	Electrical Characteristics				
Cooling	Heating			Volt	Phase	Hz	MCA (A)	MOP (A)
14.9	10.1	639x1	48-13/16x66-17/32x29-29/32	460	3	60	26.4	35

### 3. Pipes

Diameter(Liq:Gas,inch)	Length(ft)
1/4 : 1/2	94.0
3/8 : 5/8	126.0
1/2 : 7/8 : 1-1/8	50.0

### 4. Branch/Header

Model Name	Quantity
PRHR063A	1
-	-
-	-

#Notes: Correction factor is corrected by such as, but not limited to, indoor unit combination, temperature, and pipe length.

The result can be slightly different from Product Data Book due to simulation.

Pipe lengths are estimations only.

Contractor is responsible for piping take-off and verification of actual pipe routing and pipe lengths.

## System Model Section - IDU

System Name: CU1-4

**Date: 07/24/2023**

System No : 4/9

### 5. Indoor Units(1)

Room	Room Load(kBtu/h)			Room Design Temp.(Return Air Temp.)(°F)				Model Name	Rated TC/Corrected TC(kBtu/h)			Corrected Capa/Room Load(%)		
	TC	SC	HC	Cooling		Heating			TC	SC	HC	TC	SC	HC
				DBT	WBT	DBT	WBT							
1st Floor/Corridor 1304	-	-	-	75.0	62.0	70.0	54.3	ARNU363NJA4	36.0/30.4	25.9/23.7	40.0/40.0	-	-	-
1st Floor/Laundry 1306	-	-	-	75.0	62.0	70.0	54.3	ARNU183TQD4	19.1/16.1	13.8/12.5	21.5/21.5	-	-	-
1st Floor/Lobby 1300	-	-	-	75.0	62.0	70.0	54.3	ARNU363TAA4	36.2/30.5	26.8/24.4	40.6/40.6	-	-	-
1st Floor/Locker Room 1312	-	-	-	75.0	62.0	70.0	54.3	ARNU183TQD4	19.1/16.1	13.8/12.5	21.5/21.5	-	-	-
1st Floor/Locker Room 1314	-	-	-	75.0	62.0	70.0	54.3	ARNU243TAA4	24.2/20.4	19.6/17.8	27.3/27.3	-	-	-
1st Floor/Office 1310	-	-	-	75.0	62.0	70.0	54.3	ARNU123TRD4	12.3/10.4	8.9/8.1	13.6/13.6	-	-	-

#Notes: Correction factor is corrected by such as, but not limited to, indoor unit combination, temperature, and pipe length.

The result can be slightly different from Product Data Book due to simulation.

Pipe lengths are estimations only.

Contractor is responsible for piping take-off and verification of actual pipe routing and pipe lengths.

EWT=Entering Water Temperature / LWT=Leaving Water Temperature.

## System Model Section - IDU

System Name: CU1-4

**Date: 07/24/2023**

System No : 4/9

### 6. Indoor Units(2)

Tag	Model Name	Type	Est. Discharge Temp.(°F)		Air flow rate (CFM)	Remark
			Cooling	Heating		
FC1-26	ARNU363NJA4	VERTICAL AHU	53.8	106.3	988.9	Setting Value: 95 / E.S.P: 0.4015 inchAq
FC1-24	ARNU183TQD4	CASSETTE 4WAY	47.0	118.7	395.5	NA
FC1-25	ARNU363TAA4	DUALVANE CST 4WAY	53.2	106.9	988.0	NA
FC1-28	ARNU183TQD4	CASSETTE 4WAY	47.0	118.7	395.5	NA
FC1-29	ARNU243TAA4	DUALVANE CST 4WAY	55.6	100.1	813.0	NA
FC1-27	ARNU123TRD4	CASSETTE 4WAY	51.8	109.7	307.3	NA

#Notes: Correction factor is corrected by such as, but not limited to, indoor unit combination, temperature, and pipe length.

The result can be slightly different from Product Data Book due to simulation.

Pipe lengths are estimations only.

Contractor is responsible for piping take-off and verification of actual pipe routing and pipe lengths.

EWT=Entering Water Temperature / LWT=Leaving Water Temperature.

## System Model Section - IDU

System Name: CU1-4

**Date: 07/24/2023**

System No : 4/9

### 7. Indoor Units(3)

Tag	Model Name	Weight	Dimension (WxHxD)	Electrical Characteristics				
				Volt	Phase	Hz	MCA (A)	RLA (A)
FC1-26	ARNU363NJA4	121 lbs	18x48-11/16x21-1/4 inch	208~230	1	60	1.40	1.12
FC1-24	ARNU183TQD4	35 lbs	22-7/16x10x22-7/16 inch	208~230	1	60	0.25	0.2
FC1-25	ARNU363TAA4	59.5 lbs	33-1/16x11-11/32x33-1/16 inch	208~230	1	60	2.09	1.67
FC1-28	ARNU183TQD4	35 lbs	22-7/16x10x22-7/16 inch	208~230	1	60	0.25	0.2
FC1-29	ARNU243TAA4	59.5 lbs	33-1/16x11-11/32x33-1/16 inch	208~230	1	60	2.09	1.67
FC1-27	ARNU123TRD4	32 lbs	22-7/16x8-7/16x22-7/16 inch	208~230	1	60	0.25	0.2

#Notes: Correction factor is corrected by such as, but not limited to, indoor unit combination, temperature, and pipe length.

The result can be slightly different from Product Data Book due to simulation.

Pipe lengths are estimations only.

Contractor is responsible for piping take-off and verification of actual pipe routing and pipe lengths.

EWT=Entering Water Temperature / LWT=Leaving Water Temperature.

## System Validation Check

System Name: CU1-4

**Date: 07/24/2023**

System No : 4/9

### 8. System Validation Check - General Condition

Contents	Limit	Current(Max value : connected unit)
Total pipe length	3280.8 ft	270.0 ft
Longest equivalent pipe length	574.1 ft	124.2 ft : ARNU243TAA4[FC1-29]
Longest pipe length after 1st branch	131.2 ft	66.0 ft : ARNU243TAA4[FC1-29]
Height difference [Above: IDU, Below: ODU]	360.9 ft	0.0 ft
Height difference [Above: ODU, Below: IDU]	360.9 ft	20.0 ft : ARNU363TAA4[FC1-25]
Height difference [IDU to IDU]	131.2 ft	0.0 ft : ARNU183TQD4[FC1-24]-ARNU183TQD4[FC1-24]
Longest actual pipe length	492.1 ft	116.0 ft : ARNU243TAA4[FC1-29]
Height difference [HRU to HRU]	98.4 ft	0.0 ft
Height difference [HRU to HRU connected in series (same branch)]	16.4 ft	0.0 ft
Height difference [HRU to IDU]	49.2 ft	0.0 ft

Note 1 : Except "Longest equivalent pipe length", the other pipe length limitations are actual length.

# System Tree Diagram

System Name: CU1-4

Date: 07/24/2023

System No : 4/9



\* : Main pipe upsized  
 \*\* : Conditional Application  
**Three pipe** : Liquid : High Gas : Low Gas  
**Two pipe** : Liquid : Gas

Thermostat, Group Control, Dry Contact, EEV Kit for Multi V Indoor  
 AHU Comm. Kit [Discharge (supply) air], AHU Comm. Kit [Return air]  
 AHU Comm. Kit [Main module], AHU Comm. Kit [Communications module]

Indoor Units : 6 of 24  
 Combination Ratio : 144.0 of 144.0 (100%)  
 Total Pipe : 270.0 of 3280.8 ft  
 ODU factory charge : 26.50 lbs  
 Additional Refrigerant : 19.25 lbs  
 Total refrigerant : 45.75 lbs  
 Minimum room volume : 1759.59 ft³  
 (Based on 26.0 lbs / 1000.0 ft³)

# System Schematic Diagram

System Name: CU1-4

Date: 07/24/2023

System No : 4/9

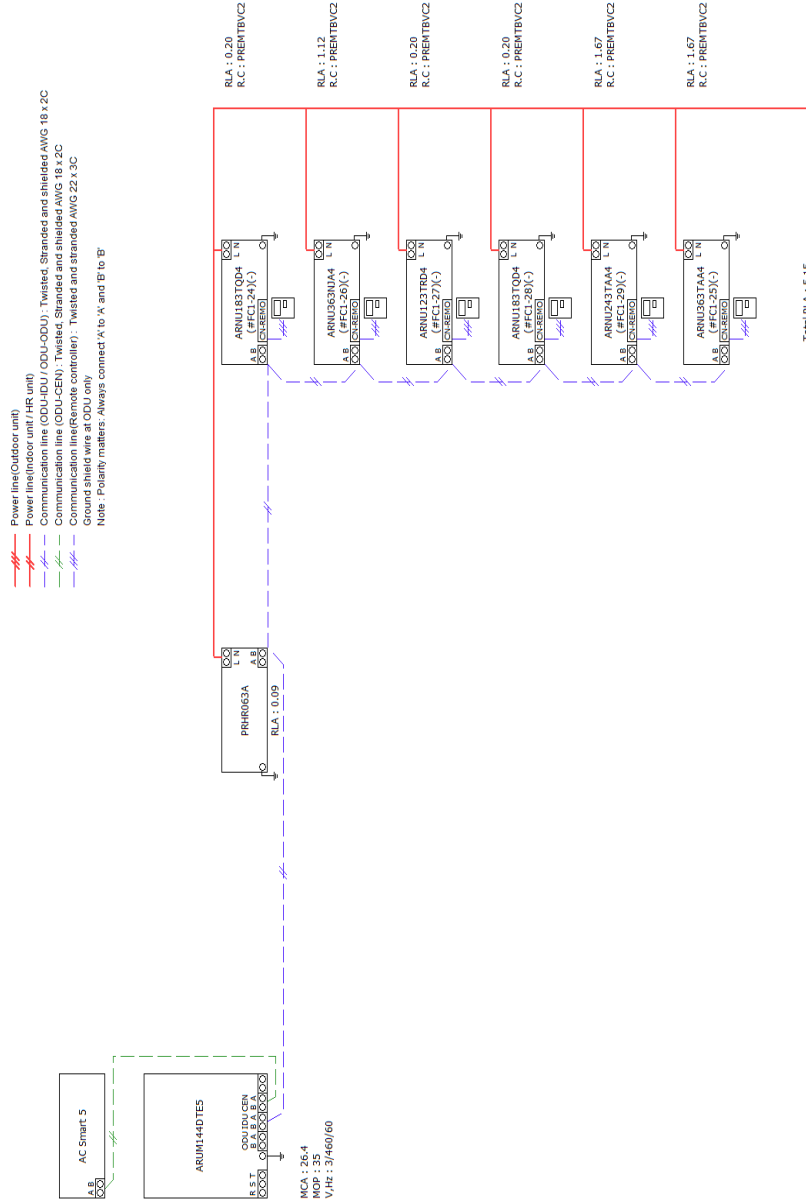

# Note :  
Power wiring, breaker size, and disconnects should follow local code and NEC.  
Multi-Frame outdoor units require a separate power connection for each frame.  
Refer to the most up-to-date submittal sheets for applicable electrical data.

## System Model Selection - ODU

System Name: CU1-5

**Date: 07/24/2023**

System No : 5/9

### 1. Design conditions - Outdoor

	Cooling			Heating		
	DBT(°F)	WBT(°F)	RH(%)	DBT(°F)	WBT(°F)	RH(%)
OAT	100.0	80.0	42.5	17.0	15.5	77.2
IAT	75.0	62.0	48.3	70.0	54.3	35.0

### 2. Outdoor Units

Model Name	No. of IDUs (Current / Max.) (EA)	Combination Ratio (Current / Max.) (%)	Corrected Capacity / Block Load (Cooling / Heating) (%)	Pre-charged Ref. amount (lbs)	Additional Ref. Amount (lbs)
ARUM144DTE5	7 / 24	94 / 130	0.0 / 0.0	26.50	21.56

Nominal/Corrected Capa. (kBtu/h)		Nominal/Corrected PI (kW)	
Cooling	Heating	Cooling	Heating
144.0/116.7	162.0/162.0	9.3/7.2	10.5/15.1

Efficiency(Btu/h/W)		Weight(lbs)	Dimension (WxHxD) (inch)	Electrical Characteristics				
Cooling	Heating			Volt	Phase	Hz	MCA (A)	MOP (A)
16.2	10.7	639x1	48-13/16x66-17/32x29-29/32	460	3	60	26.4	35

### 3. Pipes

Diameter(Liq:Gas,inch)	Length(ft)
1/4 : 1/2	164.0
3/8 : 5/8	104.0
3/8 : 1/2 : 5/8	32.0
3/8 : 3/4 : 7/8	21.0
1/2 : 7/8 : 1-1/8	40.0

### 4. Branch/Header

Model Name	Quantity
ARBLB03321	1
PRHR023A	1
PRHR063A	1
-	-
-	-

#Notes: Correction factor is corrected by such as, but not limited to, indoor unit combination, temperature, and pipe length.

The result can be slightly different from Product Data Book due to simulation.

Pipe lengths are estimations only.

Contractor is responsible for piping take-off and verification of actual pipe routing and pipe lengths.

## System Model Section - IDU

System Name: CU1-5

**Date: 07/24/2023**

System No : 5/9

### 5. Indoor Units(1)

Room	Room Load(kBtu/h)			Room Design Temp.(Return Air Temp.)(°F)				Model Name	Rated TC/Corrected TC(kBtu/h)			Corrected Capa/Room Load(%)		
	TC	SC	HC	Cooling		Heating			TC	SC	HC	TC	SC	HC
				DBT	WBT	DBT	WBT							
1st Floor/Corridor 1429	-	-	-	75.0	62.0	70.0	54.3	ARNU183TQD4	19.1/16.1	13.8/12.5	21.5/21.5	-	-	-
1st Floor/Corridor 1429	-	-	-	75.0	62.0	70.0	54.3	ARNU183TQD4	19.1/16.1	13.8/12.5	21.5/21.5	-	-	-
1st Floor/Health Center 1404	-	-	-	75.0	62.0	70.0	54.3	ARNU183TQD4	19.1/16.1	13.8/12.5	21.5/21.5	-	-	-
1st Floor/Health Classroom 1416	-	-	-	75.0	62.0	70.0	54.3	ARNU363TAA4	36.2/30.5	26.8/24.4	40.6/40.6	-	-	-
1st Floor/Locker Room 1418	-	-	-	75.0	62.0	70.0	54.3	ARNU243TAA4	24.2/20.4	19.6/17.8	27.3/27.3	-	-	-
1st Floor/Office 1410	-	-	-	75.0	62.0	70.0	54.3	ARNU093TRD4	9.6/8.1	6.9/6.3	10.9/10.9	-	-	-
1st Floor/Training Room 1414	-	-	-	75.0	62.0	70.0	54.3	ARNU123TRD4	12.3/10.4	8.9/8.1	13.6/13.6	-	-	-

#Notes: Correction factor is corrected by such as, but not limited to, indoor unit combination, temperature, and pipe length.

The result can be slightly different from Product Data Book due to simulation.

Pipe lengths are estimations only.

Contractor is responsible for piping take-off and verification of actual pipe routing and pipe lengths.

EWT=Entering Water Temperature / LWT=Leaving Water Temperature.

## System Model Section - IDU

System Name: CU1-5

**Date: 07/24/2023**

System No : 5/9

### 6. Indoor Units(2)

Tag	Model Name	Type	Est. Discharge Temp.(°F)		Air flow rate (CFM)	Remark
			Cooling	Heating		
FC1-38	ARNU183TQD4	CASSETTE 4WAY	47.0	118.7	395.5	NA
FC1-34	ARNU183TQD4	CASSETTE 4WAY	47.0	118.7	395.5	NA
FC1-40	ARNU183TQD4	CASSETTE 4WAY	47.0	118.7	395.5	NA
FC1-35	ARNU363TAA4	DUALVANE CST 4WAY	53.2	106.9	988.0	NA
FC1-36	ARNU243TAA4	DUALVANE CST 4WAY	55.6	100.1	813.0	NA
FC1-39	ARNU093TRD4	CASSETTE 4WAY	55.3	104.5	283.0	NA
FC1-37	ARNU123TRD4	CASSETTE 4WAY	51.8	109.7	307.3	NA

#Notes: Correction factor is corrected by such as, but not limited to, indoor unit combination, temperature, and pipe length.

The result can be slightly different from Product Data Book due to simulation.

Pipe lengths are estimations only.

Contractor is responsible for piping take-off and verification of actual pipe routing and pipe lengths.

EWT=Entering Water Temperature / LWT=Leaving Water Temperature.

## System Model Section - IDU

System Name: CU1-5

**Date: 07/24/2023**

System No : 5/9

### 7. Indoor Units(3)

Tag	Model Name	Weight	Dimension (WxHxD)	Electrical Characteristics				
				Volt	Phase	Hz	MCA (A)	RLA (A)
FC1-38	ARNU183TQD4	35 lbs	22-7/16x10x22-7/16 inch	208~230	1	60	0.25	0.2
FC1-34	ARNU183TQD4	35 lbs	22-7/16x10x22-7/16 inch	208~230	1	60	0.25	0.2
FC1-40	ARNU183TQD4	35 lbs	22-7/16x10x22-7/16 inch	208~230	1	60	0.25	0.2
FC1-35	ARNU363TAA4	59.5 lbs	33-1/16x11-11/32x33-1/16 inch	208~230	1	60	2.09	1.67
FC1-36	ARNU243TAA4	59.5 lbs	33-1/16x11-11/32x33-1/16 inch	208~230	1	60	2.09	1.67
FC1-39	ARNU093TRD4	32 lbs	22-7/16x8-7/16x22-7/16 inch	208~230	1	60	0.25	0.2
FC1-37	ARNU123TRD4	32 lbs	22-7/16x8-7/16x22-7/16 inch	208~230	1	60	0.25	0.2

#Notes: Correction factor is corrected by such as, but not limited to, indoor unit combination, temperature, and pipe length.

The result can be slightly different from Product Data Book due to simulation.

Pipe lengths are estimations only.

Contractor is responsible for piping take-off and verification of actual pipe routing and pipe lengths.

EWT=Entering Water Temperature / LWT=Leaving Water Temperature.

## System Validation Check

System Name: CU1-5

**Date: 07/24/2023**

System No : 5/9

### 8. System Validation Check - General Condition

Contents	Limit	Current(Max value : connected unit)
Total pipe length	3280.8 ft	361.0 ft
Longest equivalent pipe length	574.1 ft	139.8 ft : ARNU183TQD4[FC1-34]
Longest pipe length after 1st branch	131.2 ft	90.0 ft : ARNU183TQD4[FC1-34]
Height difference [Above: IDU, Below: ODU]	360.9 ft	0.0 ft
Height difference [Above: ODU, Below: IDU]	360.9 ft	20.0 ft : ARNU183TQD4[FC1-40]
Height difference [IDU to IDU]	131.2 ft	0.0 ft : ARNU183TQD4[FC1-38]-ARNU183TQD4[FC1-38]
Longest actual pipe length	492.1 ft	130.0 ft : ARNU183TQD4[FC1-34]
Height difference [HRU to HRU]	98.4 ft	0.0 ft
Height difference [HRU to HRU connected in series (same branch)]	16.4 ft	0.0 ft
Height difference [HRU to IDU]	49.2 ft	0.0 ft

Note 1 : Except "Longest equivalent pipe length", the other pipe length limitations are actual length.

# System Tree Diagram

System Name: CU1-5

Date: 07/24/2023

System No : 5/9

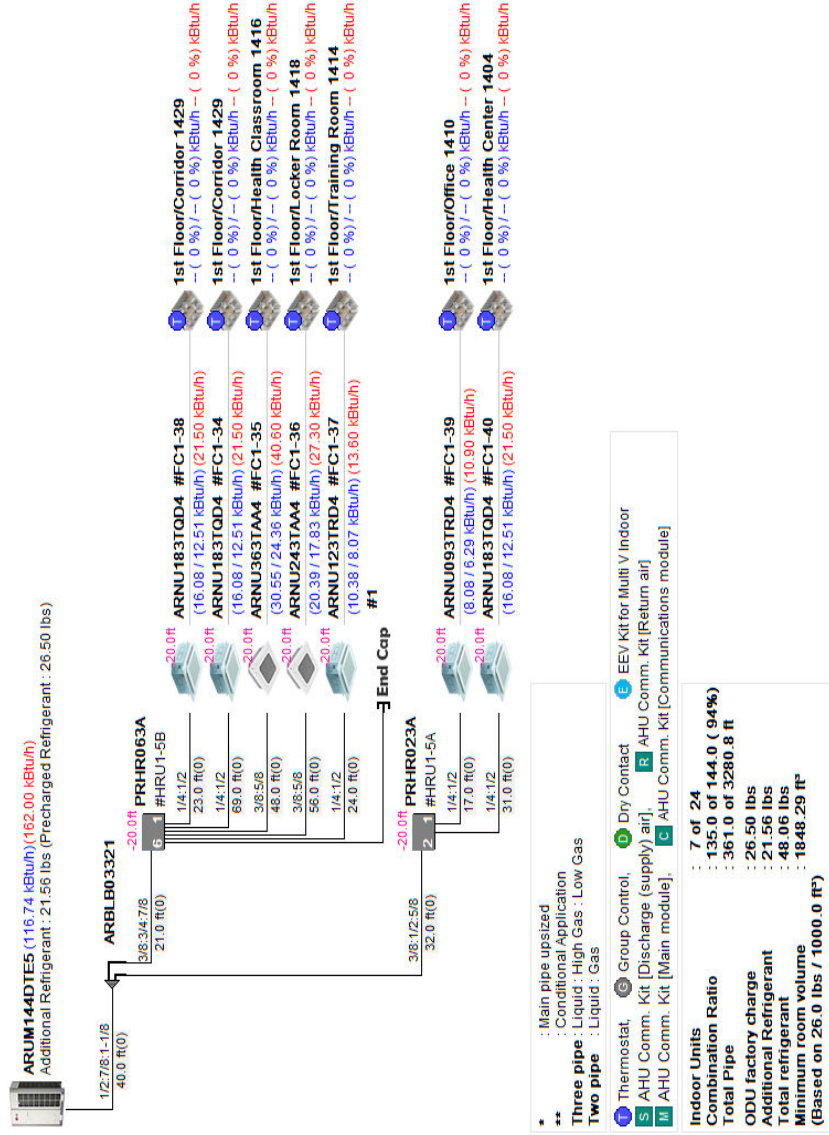

# System Schematic Diagram

System Name: CU1-5

**Date: 07/24/2023**

System No : 5/9

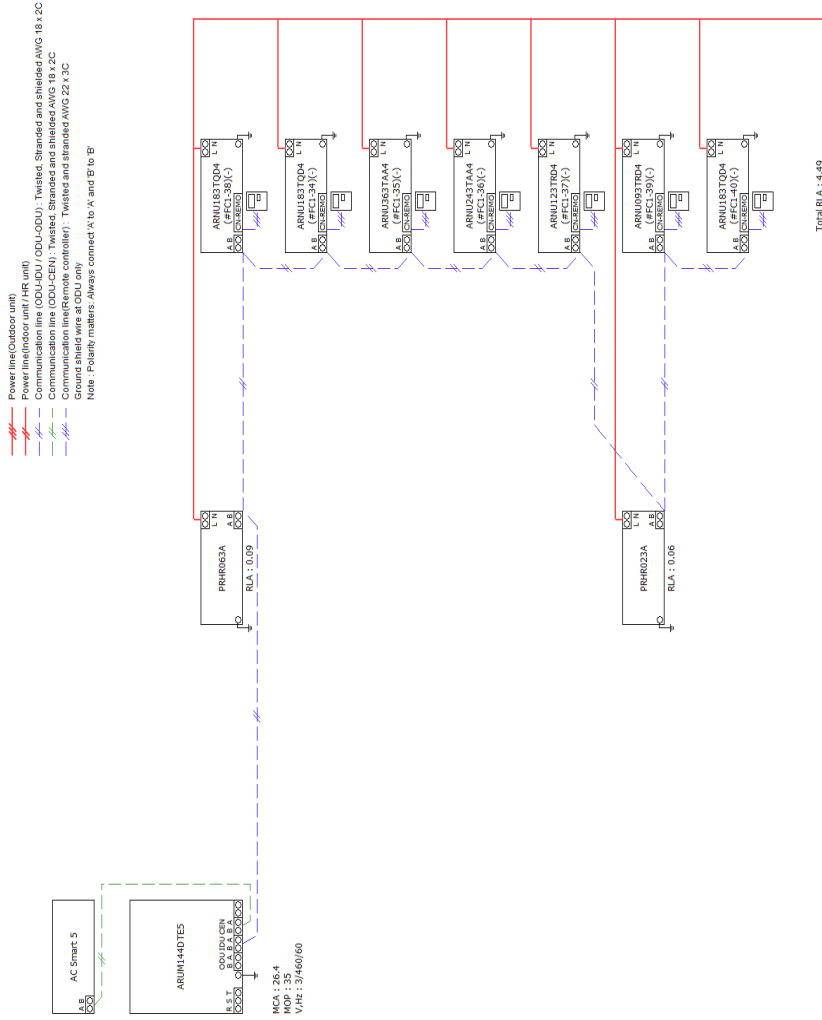

# Note :  
 Power wiring, breaker size, and disconnects should follow local code and NEC.  
 Multi-frame outdoor units require a separate power connection for each frame.  
 Refer to the most up-to-date submittal sheets for applicable electrical data.

## System Model Selection - ODU

System Name: CU1-6

**Date: 07/24/2023**

System No : 6/9

### 1. Design conditions - Outdoor

	Cooling			Heating		
	DBT(°F)	WBT(°F)	RH(%)	DBT(°F)	WBT(°F)	RH(%)
OAT	100.0	80.0	42.5	17.0	15.5	77.2
IAT	75.0	62.0	48.3	70.0	54.3	35.0

### 2. Outdoor Units

Model Name	No. of IDUs (Current / Max.) (EA)	Combination Ratio (Current / Max.) (%)	Corrected Capacity / Block Load (Cooling / Heating) (%)	Pre-charged Ref. amount (lbs)	Additional Ref. Amount (lbs)
ARUM168DTE5	5 / 29	96 / 130	0.0 / 0.0	26.50	27.13

Nominal/Corrected Capa. (kBtu/h)		Nominal/Corrected PI (kW)	
Cooling	Heating	Cooling	Heating
168.0/135.0	189.0/189.0	12.2/9.9	14.0/20.6

Efficiency(Btu/h/W)		Weight(lbs)	Dimension (WxHxD) (inch)	Electrical Characteristics				
Cooling	Heating			Volt	Phase	Hz	MCA (A)	MOP (A)
13.7	9.2	639x1	48-13/16x66-17/32x29-29/32	460	3	60	28.4	35

### 3. Pipes

Diameter(Liq:Gas,inch)	Length(ft)
1/4 : 1/2	49.0
3/8 : 5/8	115.0
5/8 : 7/8 : 1-1/8	110.0

### 4. Branch/Header

Model Name	Quantity
PRHR063A	1
-	-
-	-

#Notes: Correction factor is corrected by such as, but not limited to, indoor unit combination, temperature, and pipe length.

The result can be slightly different from Product Data Book due to simulation.

Pipe lengths are estimations only.

Contractor is responsible for piping take-off and verification of actual pipe routing and pipe lengths.

## System Model Section - IDU

System Name: CU1-6

**Date: 07/24/2023**

System No : 6/9

### 5. Indoor Units(1)

Room	Room Load(kBtu/h)			Room Design Temp.(Return Air Temp.)(°F)				Model Name	Rated TC/Corrected TC(kBtu/h)			Corrected Capa/Room Load(%)		
	TC	SC	HC	Cooling		Heating			TC	SC	HC	TC	SC	HC
				DBT	WBT	DBT	WBT							
1st Floor/JH Art Room 1106	-	-	-	75.0	62.0	70.0	54.3	ARNU363TAA4	36.2/30.5	26.8/24.4	40.6/40.6	-	-	-
1st Floor/JH Art Room 1106	-	-	-	75.0	62.0	70.0	54.3	ARNU363TAA4	36.2/30.5	26.8/24.4	40.6/40.6	-	-	-
1st Floor/JH Instrumental Room 1104	-	-	-	75.0	62.0	70.0	54.3	ARNU363TAA4	36.2/30.5	26.8/24.4	40.6/40.6	-	-	-
1st Floor/JH Instrumental Room 1104	-	-	-	75.0	62.0	70.0	54.3	ARNU363TAA4	36.2/30.5	26.8/24.4	40.6/40.6	-	-	-
1st Floor/Workroom 1102	-	-	-	75.0	62.0	70.0	54.3	ARNU183TQD4	19.1/16.1	13.8/12.5	21.5/21.5	-	-	-

#Notes: Correction factor is corrected by such as, but not limited to, indoor unit combination, temperature, and pipe length.

The result can be slightly different from Product Data Book due to simulation.

Pipe lengths are estimations only.

Contractor is responsible for piping take-off and verification of actual pipe routing and pipe lengths.

EWT=Entering Water Temperature / LWT=Leaving Water Temperature.

## System Model Section - IDU

System Name: CU1-6

**Date: 07/24/2023**

System No : 6/9

### 6. Indoor Units(2)

Tag	Model Name	Type	Est. Discharge Temp.(°F)		Air flow rate (CFM)	Remark
			Cooling	Heating		
FC1-41	ARNU363TAA4	DUALVANE CST 4WAY	53.2	106.9	988.0	NA
FC1-42	ARNU363TAA4	DUALVANE CST 4WAY	53.2	106.9	988.0	NA
FC1-44	ARNU363TAA4	DUALVANE CST 4WAY	53.2	106.9	988.0	NA
FC1-43	ARNU363TAA4	DUALVANE CST 4WAY	53.2	106.9	988.0	NA
FC1-9	ARNU183TQD4	CASSETTE 4WAY	47.0	118.7	395.5	NA

#Notes: Correction factor is corrected by such as, but not limited to, indoor unit combination, temperature, and pipe length.

The result can be slightly different from Product Data Book due to simulation.

Pipe lengths are estimations only.

Contractor is responsible for piping take-off and verification of actual pipe routing and pipe lengths.

EWT=Entering Water Temperature / LWT=Leaving Water Temperature.

## System Model Section - IDU

System Name: CU1-6

**Date: 07/24/2023**

System No : 6/9

### 7. Indoor Units(3)

Tag	Model Name	Weight	Dimension (WxHxD)	Electrical Characteristics				
				Volt	Phase	Hz	MCA (A)	RLA (A)
FC1-41	ARNU363TAA4	59.5 lbs	33-1/16x11-11/32x33-1/16 inch	208~230	1	60	2.09	1.67
FC1-42	ARNU363TAA4	59.5 lbs	33-1/16x11-11/32x33-1/16 inch	208~230	1	60	2.09	1.67
FC1-44	ARNU363TAA4	59.5 lbs	33-1/16x11-11/32x33-1/16 inch	208~230	1	60	2.09	1.67
FC1-43	ARNU363TAA4	59.5 lbs	33-1/16x11-11/32x33-1/16 inch	208~230	1	60	2.09	1.67
FC1-9	ARNU183TQD4	35 lbs	22-7/16x10x22-7/16 inch	208~230	1	60	0.25	0.2

#Notes: Correction factor is corrected by such as, but not limited to, indoor unit combination, temperature, and pipe length.

The result can be slightly different from Product Data Book due to simulation.

Pipe lengths are estimations only.

Contractor is responsible for piping take-off and verification of actual pipe routing and pipe lengths.

EWT=Entering Water Temperature / LWT=Leaving Water Temperature.

## System Validation Check

System Name: CU1-6

**Date: 07/24/2023**

System No : 6/9

### 8. System Validation Check - General Condition

Contents	Limit	Current(Max value : connected unit)
Total pipe length	3280.8 ft	274.0 ft
Longest equivalent pipe length	574.1 ft	167.2 ft : ARNU183TQD4[FC1-9]
Longest pipe length after 1st branch	131.2 ft	49.0 ft : ARNU183TQD4[FC1-9]
Height difference [Above: IDU, Below: ODU]	360.9 ft	0.0 ft
Height difference [Above: ODU, Below: IDU]	360.9 ft	20.0 ft : ARNU363TAA4[FC1-42]
Height difference [IDU to IDU]	131.2 ft	0.0 ft : ARNU183TQD4[FC1-9]-ARNU183TQD4[FC1-9]
Longest actual pipe length	492.1 ft	159.0 ft : ARNU183TQD4[FC1-9]
Height difference [HRU to HRU]	98.4 ft	0.0 ft
Height difference [HRU to HRU connected in series (same branch)]	16.4 ft	0.0 ft
Height difference [HRU to IDU]	49.2 ft	0.0 ft

Note 1 : Except "Longest equivalent pipe length", the other pipe length limitations are actual length.

# System Tree Diagram

System Name: CU1-6

Date: 07/24/2023

System No : 6/9

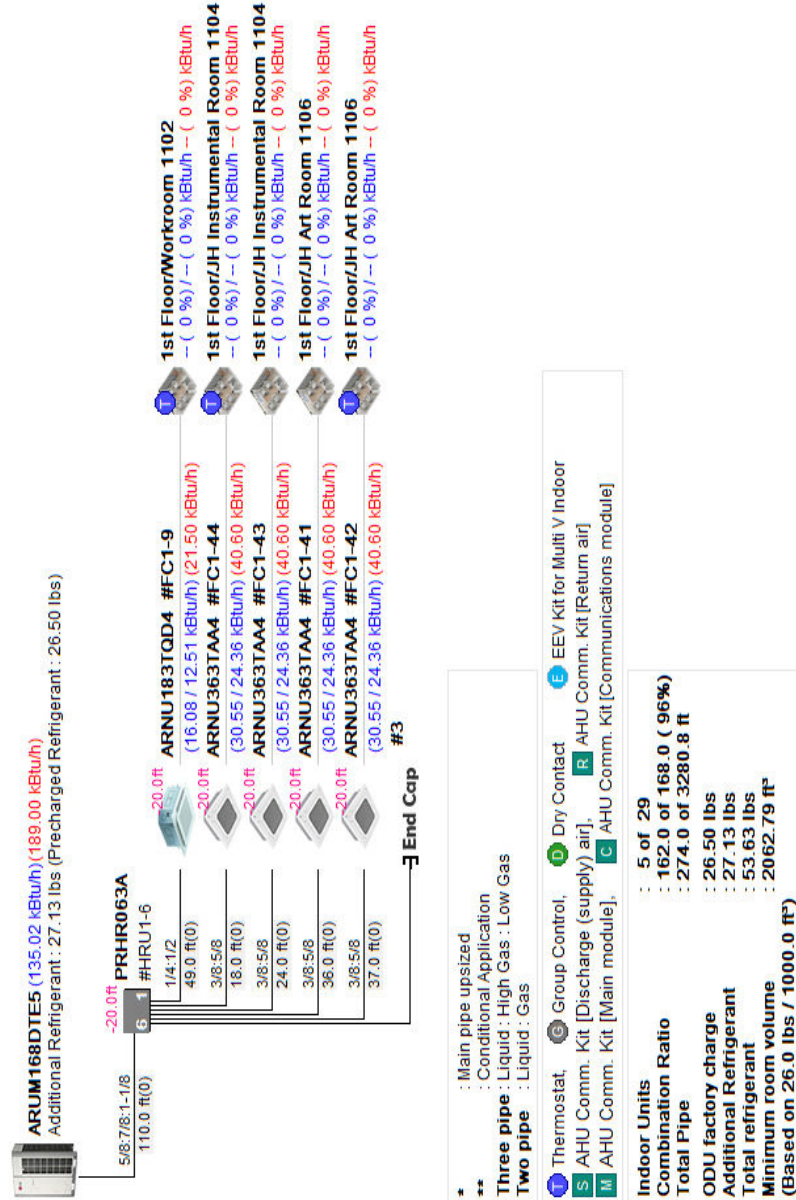

# System Schematic Diagram

System Name: CU1-6

**Date: 07/24/2023**

System No : 6/9

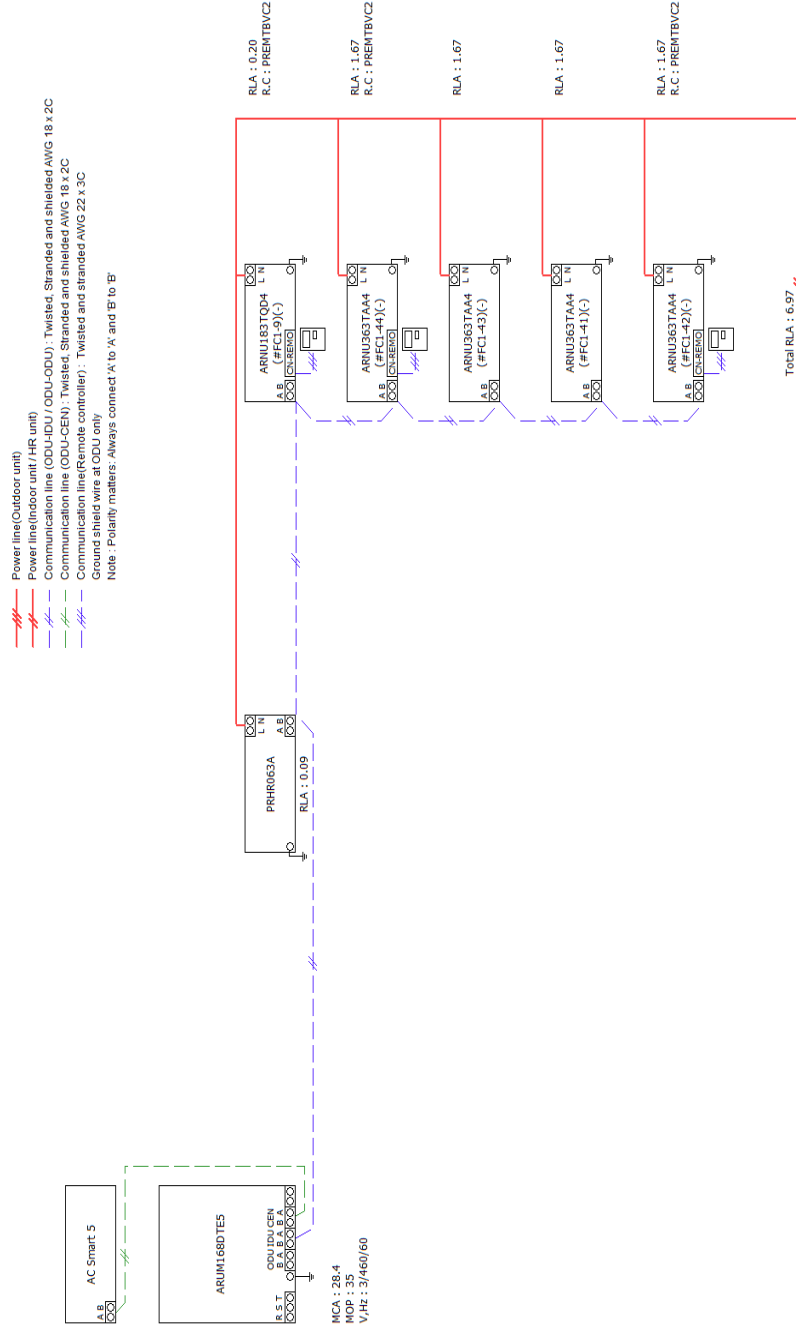

# Note :  
 Power wiring, breaker size, and disconnects should follow local code and NEC.  
 Multi-frame outdoor units require a separate power connection for each frame.  
 Refer to the most up-to-date submittal sheets for applicable electrical data.

## System Model Selection - ODU

System Name: CU2-1

**Date: 07/24/2023**

System No : 7/9

### 1. Design conditions - Outdoor

	Cooling			Heating		
	DBT(°F)	WBT(°F)	RH(%)	DBT(°F)	WBT(°F)	RH(%)
OAT	100.0	80.0	42.5	17.0	15.5	77.2
IAT	75.0	62.0	48.3	70.0	54.3	35.0

### 2. Outdoor Units

Model Name	No. of IDUs (Current / Max.) (EA)	Combination Ratio (Current / Max.) (%)	Corrected Capacity / Block Load (Cooling / Heating) (%)	Pre-charged Ref. amount (lbs)	Additional Ref. Amount (lbs)
ARUM312DTE5	11 / 52	114 / 130	0.0 / 0.0	60.70	61.50

Model Name	Combination
ARUM312DTE5	ARUM096DTE5 + ARUM216DTE5

Nominal/Corrected Capa. (kBtu/h)		Nominal/Corrected PI (kW)	
Cooling	Heating	Cooling	Heating
312.0/275.3	351.0/395.6	20.7/18.9	24.5/38.3

Efficiency(Btu/h/W)		Weight(lbs)	Dimension (WxHxD) (inch)	Electrical Characteristics				
Cooling	Heating			Volt	Phase	Hz	MCA (A)	MOP (A)
14.6	10.3	(507x1)+(666x1)	(48-13/16x66-17/32x29-29/32)x2	460	3	60	16.4+38.3	25+50

### 3. Pipes

Diameter(Liq:Gas,inch)	Length(ft)
1/4 : 1/2	76.0
3/8 : 5/8	503.0
5/8 : 7/8 : 1-1/8	32.0

### 4. Branch/Header

Model Name	Quantity
ARBLB07121	1
ARCNB21	1
PRHR063A	2

#Notes: Correction factor is corrected by such as, but not limited to, indoor unit combination, temperature, and pipe length.

The result can be slightly different from Product Data Book due to simulation.

Pipe lengths are estimations only.

Contractor is responsible for piping take-off and verification of actual pipe routing and pipe lengths.

## System Model Selection - ODU

System Name: CU2-1

**Date: 07/24/2023**

System No : 7/9

### 3. Pipes

Diameter(Liq:Gas,inch)	Length(ft)
3/4 : 1-1/8 : 1-3/8	90.0

### 4. Branch/Header

Model Name	Quantity
-	-

#Notes: Correction factor is corrected by such as, but not limited to, indoor unit combination, temperature, and pipe length.

The result can be slightly different from Product Data Book due to simulation.

Pipe lengths are estimations only.

Contractor is responsible for piping take-off and verification of actual pipe routing and pipe lengths.

## System Model Selection - ODU

System Name: CU2-1

**Date: 07/24/2023**

System No : 7/9

### 5. ODU Installation

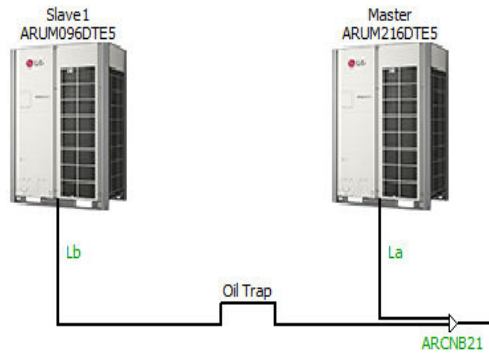

\* Oil Trap : Apply when height difference or distance between the ODUs is over 2m(6.6ft).

Outdoor Unit-Branch		
Pipe	Diameter(inch)	Length(ft)
La	5/8 : 1-1/8 : 1-1/8	-
Lb	3/8 : 3/4 : 7/8	-

Height Difference	
Pipe	Length(ft)
Hb (Master-Slave1)	-

#Notes: Height difference is calculated based on master ODU.

## System Model Section - IDU

System Name: CU2-1

**Date: 07/24/2023**

System No : 7/9

### 6. Indoor Units(1)

Room	Room Load(kBtu/h)			Room Design Temp.(Return Air Temp.)(°F)				Model Name	Rated TC/Corrected TC(kBtu/h)			Corrected Capa/Room Load(%)		
	TC	SC	HC	Cooling		Heating			TC	SC	HC	TC	SC	HC
				DBT	WBT	DBT	WBT							
2nd Floor/Classroom 2108	-	-	-	75.0	62.0	70.0	54.3	ARNU363TAA4	36.2/30.5	26.8/24.4	40.6/40.6	-	-	-
2nd Floor/Classroom 2105	-	-	-	75.0	62.0	70.0	54.3	ARNU363TAA4	36.2/30.5	26.8/24.4	40.6/40.6	-	-	-
2nd Floor/Classroom 2107	-	-	-	75.0	62.0	70.0	54.3	ARNU363TAA4	36.2/30.5	26.8/24.4	40.6/40.6	-	-	-
2nd Floor/Classroom 2204	-	-	-	75.0	62.0	70.0	54.3	ARNU363TAA4	36.2/30.5	26.8/24.4	40.6/40.6	-	-	-
2nd Floor/Classroom 2206	-	-	-	75.0	62.0	70.0	54.3	ARNU363TAA4	36.2/30.5	26.8/24.4	40.6/40.6	-	-	-
2nd Floor/Classroom 2207	-	-	-	75.0	62.0	70.0	54.3	ARNU363TAA4	36.2/30.5	26.8/24.4	40.6/40.6	-	-	-
2nd Floor/Instructional MP 2104	-	-	-	75.0	62.0	70.0	54.3	ARNU363TAA4	36.2/30.5	26.8/24.4	40.6/40.6	-	-	-
2nd Floor/Instructional MP 2204	-	-	-	75.0	62.0	70.0	54.3	ARNU363TAA4	36.2/30.5	26.8/24.4	40.6/40.6	-	-	-
2nd Floor/Science Lab 2201	-	-	-	75.0	62.0	70.0	54.3	ARNU283TAA4	28.0/23.6	21.3/19.4	31.5/31.5	-	-	-
2nd Floor/Science Lab 2201	-	-	-	75.0	62.0	70.0	54.3	ARNU283TAA4	28.0/23.6	21.3/19.4	31.5/31.5	-	-	-
2nd Floor/Science Prep 2202	-	-	-	75.0	62.0	70.0	54.3	ARNU123TRD4	12.3/10.4	8.9/8.1	13.6/13.6	-	-	-

#Notes: Correction factor is corrected by such as, but not limited to, indoor unit combination, temperature, and pipe length.

The result can be slightly different from Product Data Book due to simulation.

Pipe lengths are estimations only.

Contractor is responsible for piping take-off and verification of actual pipe routing and pipe lengths.

EWT=Entering Water Temperature / LWT=Leaving Water Temperature.

## System Model Section - IDU

System Name: CU2-1

**Date: 07/24/2023**

System No : 7/9

### 7. Indoor Units(2)

Tag	Model Name	Type	Est. Discharge Temp.(°F)		Air flow rate (CFM)	Remark
			Cooling	Heating		
FC2-1	ARNU363TAA4	DUALVANE CST 4WAY	53.2	106.9	988.0	NA
FC2-2	ARNU363TAA4	DUALVANE CST 4WAY	53.2	106.9	988.0	NA
FC2-3	ARNU363TAA4	DUALVANE CST 4WAY	53.2	106.9	988.0	NA
FC2-26	ARNU363TAA4	DUALVANE CST 4WAY	53.2	106.9	988.0	NA
FC2-5	ARNU363TAA4	DUALVANE CST 4WAY	53.2	106.9	988.0	NA
FC2-7	ARNU363TAA4	DUALVANE CST 4WAY	53.2	106.9	988.0	NA
FC2-4	ARNU363TAA4	DUALVANE CST 4WAY	53.2	106.9	988.0	NA
FC2-6	ARNU363TAA4	DUALVANE CST 4WAY	53.2	106.9	988.0	NA
FC2-8	ARNU283TAA4	DUALVANE CST 4WAY	54.9	103.0	855.0	NA
FC2-9	ARNU283TAA4	DUALVANE CST 4WAY	54.9	103.0	855.0	NA
FC2-10	ARNU123TRD4	CASSETTE 4WAY	51.8	109.7	307.3	NA

#Notes: Correction factor is corrected by such as, but not limited to, indoor unit combination, temperature, and pipe length.

The result can be slightly different from Product Data Book due to simulation.

Pipe lengths are estimations only.

Contractor is responsible for piping take-off and verification of actual pipe routing and pipe lengths.

EWT=Entering Water Temperature / LWT=Leaving Water Temperature.

## System Model Section - IDU

System Name: CU2-1

**Date: 07/24/2023**

System No : 7/9

### 8. Indoor Units(3)

Tag	Model Name	Weight	Dimension (WxHxD)	Electrical Characteristics				
				Volt	Phase	Hz	MCA (A)	RLA (A)
FC2-1	ARNU363TAA4	59.5 lbs	33-1/16x11-11/32x33-1/16 inch	208~230	1	60	2.09	1.67
FC2-2	ARNU363TAA4	59.5 lbs	33-1/16x11-11/32x33-1/16 inch	208~230	1	60	2.09	1.67
FC2-3	ARNU363TAA4	59.5 lbs	33-1/16x11-11/32x33-1/16 inch	208~230	1	60	2.09	1.67
FC2-26	ARNU363TAA4	59.5 lbs	33-1/16x11-11/32x33-1/16 inch	208~230	1	60	2.09	1.67
FC2-5	ARNU363TAA4	59.5 lbs	33-1/16x11-11/32x33-1/16 inch	208~230	1	60	2.09	1.67
FC2-7	ARNU363TAA4	59.5 lbs	33-1/16x11-11/32x33-1/16 inch	208~230	1	60	2.09	1.67
FC2-4	ARNU363TAA4	59.5 lbs	33-1/16x11-11/32x33-1/16 inch	208~230	1	60	2.09	1.67
FC2-6	ARNU363TAA4	59.5 lbs	33-1/16x11-11/32x33-1/16 inch	208~230	1	60	2.09	1.67
FC2-8	ARNU283TAA4	59.5 lbs	33-1/16x11-11/32x33-1/16 inch	208~230	1	60	2.09	1.67
FC2-9	ARNU283TAA4	59.5 lbs	33-1/16x11-11/32x33-1/16 inch	208~230	1	60	2.09	1.67
FC2-10	ARNU123TRD4	32 lbs	22-7/16x8-7/16x22-7/16 inch	208~230	1	60	0.25	0.2

#Notes: Correction factor is corrected by such as, but not limited to, indoor unit combination, temperature, and pipe length.

The result can be slightly different from Product Data Book due to simulation.

Pipe lengths are estimations only.

Contractor is responsible for piping take-off and verification of actual pipe routing and pipe lengths.

EWT=Entering Water Temperature / LWT=Leaving Water Temperature.

## System Validation Check

System Name: CU2-1

**Date: 07/24/2023**

System No : 7/9

### 9. System Validation Check - General Condition

Contents	Limit	Current(Max value : connected unit)
Total pipe length	3280.8 ft	701.0 ft
Longest equivalent pipe length	574.1 ft	199.8 ft : ARNU363TAA4[FC2-2]
Longest pipe length after 1st branch	131.2 ft	100.0 ft : ARNU363TAA4[FC2-2]
Height difference [Above: IDU, Below: ODU]	360.9 ft	0.0 ft
Height difference [Above: ODU, Below: IDU]	360.9 ft	9.8 ft : ARNU363TAA4[FC2-26]
Height difference [IDU to IDU]	131.2 ft	4.8 ft : ARNU363TAA4[FC2-5]-ARNU363TAA4[FC2-26]
Longest actual pipe length	492.1 ft	190.0 ft : ARNU363TAA4[FC2-2]
Height difference [HRU to HRU]	98.4 ft	0.0 ft
Height difference [HRU to HRU connected in series (same branch)]	16.4 ft	0.0 ft
Height difference [HRU to IDU]	49.2 ft	4.8 ft

Note 1 : Except "Longest equivalent pipe length", the other pipe length limitations are actual length.

# System Tree Diagram

System Name: CU2-1

**Date: 07/24/2023**

System No : 7/9

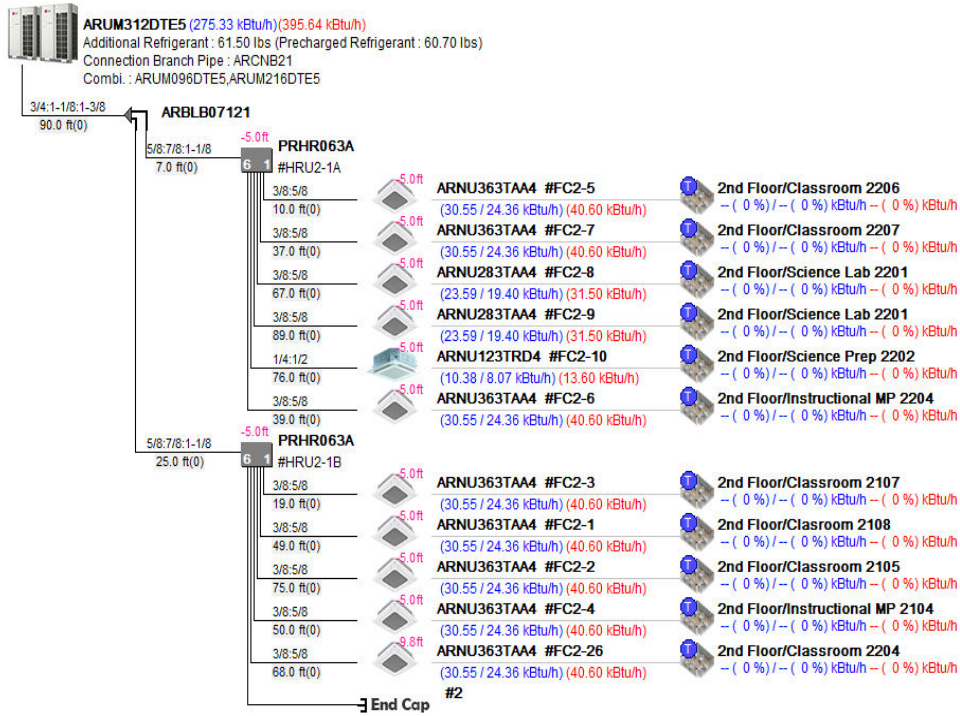

\* : Main pipe upsized  
 \*\* : Conditional Application  
**Three pipe** : Liquid : High Gas : Low Gas  
**Two pipe** : Liquid : Gas

Thermostat, 
 Group Control, 
 Dry Contact, 
 EEV Kit for Multi V Indoor  
 AHU Comm. Kit [Discharge (supply) air], 
 AHU Comm. Kit [Return air]  
 AHU Comm. Kit [Main module], 
 AHU Comm. Kit [Communications module]

**Indoor Units** : 11 of 52  
**Combination Ratio** : 356.0 of 312.0 (114%)  
**Total Pipe** : 701.0 of 3280.8 ft  
**ODU factory charge** : 60.70 lbs  
**Additional Refrigerant** : 61.50 lbs  
**Total refrigerant** : 122.20 lbs  
**Minimum room volume** : 4700.01 ft³  
 (Based on 26.0 lbs / 1000.0 ft³)

# System Schematic Diagram

System Name: CU2-1

**Date: 07/24/2023**

System No : 7/9

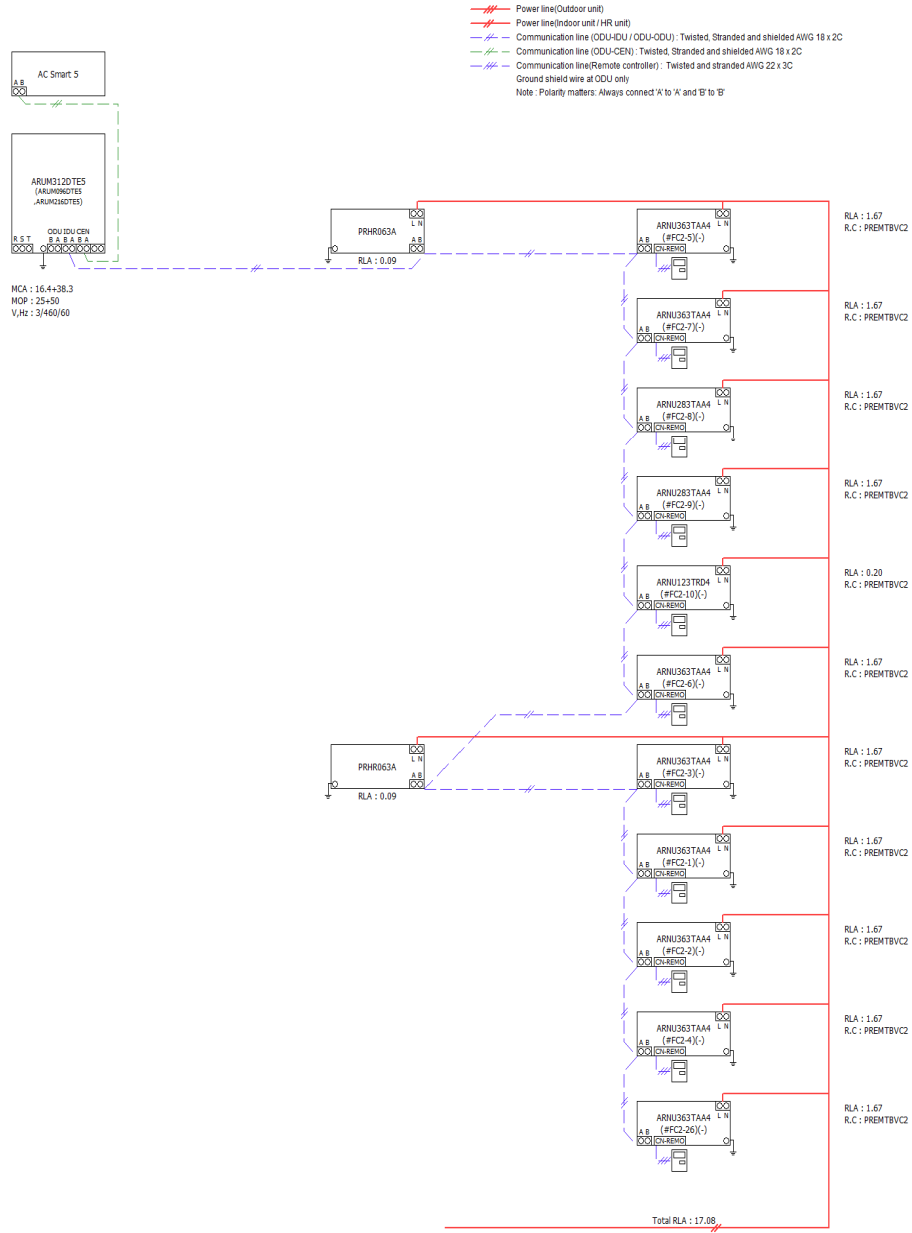

# Note :  
 Power wiring, breaker size, and disconnects should follow local code and NEC.  
 Multi-frame outdoor units require a separate power connection for each frame.  
 Refer to the most up-to-date submittal sheets for applicable electrical data.

## System Model Selection - ODU

System Name: CU2-2

**Date: 07/24/2023**

System No : 8/9

### 1. Design conditions - Outdoor

	Cooling			Heating		
	DBT(°F)	WBT(°F)	RH(%)	DBT(°F)	WBT(°F)	RH(%)
OAT	100.0	80.0	42.5	17.0	15.5	77.2
IAT	75.0	62.0	48.3	70.0	54.3	35.0

### 2. Outdoor Units

Model Name	No. of IDUs (Current / Max.) (EA)	Combination Ratio (Current / Max.) (%)	Corrected Capacity / Block Load (Cooling / Heating) (%)	Pre-charged Ref. amount (lbs)	Additional Ref. Amount (lbs)
ARUM241DTE5	10 / 39	103 / 130	0.0 / 0.0	37.50	29.93

Nominal/Corrected Capa. (kBtu/h)		Nominal/Corrected PI (kW)	
Cooling	Heating	Cooling	Heating
233.1/194.5	243.0/248.6	16.8/14.5	17.8/27.1

Efficiency(Btu/h/W)		Weight(lbs)	Dimension (WxHxD) (inch)	Electrical Characteristics				
Cooling	Heating			Volt	Phase	Hz	MCA (A)	MOP (A)
13.4	9.2	666x1	48-13/16x66-17/32x29-29/32	460	3	60	41.4	50

### 3. Pipes

Diameter(Liq:Gas,inch)	Length(ft)
1/4 : 1/2	199.0
3/8 : 5/8	136.0
1/2 : 7/8 : 1-1/8	72.0
5/8 : 1-1/8 : 1-3/8	20.0

### 4. Branch/Header

Model Name	Quantity
ARBLB07121	1
PRHR043A	1
PRHR063A	1
-	-

#Notes: Correction factor is corrected by such as, but not limited to, indoor unit combination, temperature, and pipe length.

The result can be slightly different from Product Data Book due to simulation.

Pipe lengths are estimations only.

Contractor is responsible for piping take-off and verification of actual pipe routing and pipe lengths.

## System Model Section - IDU

System Name: CU2-2

**Date: 07/24/2023**

System No : 8/9

### 5. Indoor Units(1)

Room	Room Load(kBtu/h)			Room Design Temp.(Return Air Temp.)(°F)				Model Name	Rated TC/Corrected TC(kBtu/h)			Corrected Capa/Room Load(%)		
	TC	SC	HC	Cooling		Heating			TC	SC	HC	TC	SC	HC
				DBT	WBT	DBT	WBT							
2nd Floor/Classroom 2208	-	-	-	75.0	62.0	70.0	54.3	ARNU363TAA4	36.2/30.5	26.8/24.4	40.6/40.6	-	-	-
2nd Floor/Classroom 2212	-	-	-	75.0	62.0	70.0	54.3	ARNU363TAA4	36.2/30.5	26.8/24.4	40.6/40.6	-	-	-
2nd Floor/Classroom 2214	-	-	-	75.0	62.0	70.0	54.3	ARNU363TAA4	36.2/30.5	26.8/24.4	40.6/40.6	-	-	-
2nd Floor/Classroom 2217	-	-	-	75.0	62.0	70.0	54.3	ARNU363TAA4	36.2/30.5	26.8/24.4	40.6/40.6	-	-	-
2nd Floor/Conference 2213	-	-	-	75.0	62.0	70.0	54.3	ARNU123TRD4	12.3/10.4	8.9/8.1	13.6/13.6	-	-	-
2nd Floor/Corr 2210	-	-	-	75.0	62.0	70.0	54.3	ARNU183TQD4	19.1/16.1	13.8/12.5	21.5/21.5	-	-	-
2nd Floor/OT/PT 2215	-	-	-	75.0	62.0	70.0	54.3	ARNU183TQD4	19.1/16.1	13.8/12.5	21.5/21.5	-	-	-
2nd Floor/OT/PT 2216	-	-	-	75.0	62.0	70.0	54.3	ARNU183TQD4	19.1/16.1	13.8/12.5	21.5/21.5	-	-	-
2nd Floor/Resource 2219	-	-	-	75.0	62.0	70.0	54.3	ARNU183TQD4	19.1/16.1	13.8/12.5	21.5/21.5	-	-	-
2nd Floor/Resource 2221	-	-	-	75.0	62.0	70.0	54.3	ARNU183TQD4	19.1/16.1	13.8/12.5	21.5/21.5	-	-	-

#Notes: Correction factor is corrected by such as, but not limited to, indoor unit combination, temperature, and pipe length.

The result can be slightly different from Product Data Book due to simulation.

Pipe lengths are estimations only.

Contractor is responsible for piping take-off and verification of actual pipe routing and pipe lengths.

EWT=Entering Water Temperature / LWT=Leaving Water Temperature.

## System Model Section - IDU

System Name: CU2-2

**Date: 07/24/2023**

System No : 8/9

### 6. Indoor Units(2)

Tag	Model Name	Type	Est. Discharge Temp.(°F)		Air flow rate (CFM)	Remark
			Cooling	Heating		
FC2-11	ARNU363TAA4	DUALVANE CST 4WAY	53.2	106.9	988.0	NA
FC2-13	ARNU363TAA4	DUALVANE CST 4WAY	53.2	106.9	988.0	NA
FC2-17	ARNU363TAA4	DUALVANE CST 4WAY	53.2	106.9	988.0	NA
FC2-20	ARNU363TAA4	DUALVANE CST 4WAY	53.2	106.9	988.0	NA
FC2-14	ARNU123TRD4	CASSETTE 4WAY	51.8	109.7	307.3	NA
FC2-12	ARNU183TQD4	CASSETTE 4WAY	47.0	118.7	395.5	NA
FC2-18	ARNU183TQD4	CASSETTE 4WAY	47.0	118.7	395.5	NA
FC2-19	ARNU183TQD4	CASSETTE 4WAY	47.0	118.7	395.5	NA
FC2-16	ARNU183TQD4	CASSETTE 4WAY	47.0	118.7	395.5	NA
FC2-15	ARNU183TQD4	CASSETTE 4WAY	47.0	118.7	395.5	NA

#Notes: Correction factor is corrected by such as, but not limited to, indoor unit combination, temperature, and pipe length.

The result can be slightly different from Product Data Book due to simulation.

Pipe lengths are estimations only.

Contractor is responsible for piping take-off and verification of actual pipe routing and pipe lengths.

EWT=Entering Water Temperature / LWT=Leaving Water Temperature.

## System Model Section - IDU

System Name: CU2-2

**Date: 07/24/2023**

System No : 8/9

### 7. Indoor Units(3)

Tag	Model Name	Weight	Dimension (WxHxD)	Electrical Characteristics				
				Volt	Phase	Hz	MCA (A)	RLA (A)
FC2-11	ARNU363TAA4	59.5 lbs	33-1/16x11-11/32x33-1/16 inch	208~230	1	60	2.09	1.67
FC2-13	ARNU363TAA4	59.5 lbs	33-1/16x11-11/32x33-1/16 inch	208~230	1	60	2.09	1.67
FC2-17	ARNU363TAA4	59.5 lbs	33-1/16x11-11/32x33-1/16 inch	208~230	1	60	2.09	1.67
FC2-20	ARNU363TAA4	59.5 lbs	33-1/16x11-11/32x33-1/16 inch	208~230	1	60	2.09	1.67
FC2-14	ARNU123TRD4	32 lbs	22-7/16x8-7/16x22-7/16 inch	208~230	1	60	0.25	0.2
FC2-12	ARNU183TQD4	35 lbs	22-7/16x10x22-7/16 inch	208~230	1	60	0.25	0.2
FC2-18	ARNU183TQD4	35 lbs	22-7/16x10x22-7/16 inch	208~230	1	60	0.25	0.2
FC2-19	ARNU183TQD4	35 lbs	22-7/16x10x22-7/16 inch	208~230	1	60	0.25	0.2
FC2-16	ARNU183TQD4	35 lbs	22-7/16x10x22-7/16 inch	208~230	1	60	0.25	0.2
FC2-15	ARNU183TQD4	35 lbs	22-7/16x10x22-7/16 inch	208~230	1	60	0.25	0.2

#Notes: Correction factor is corrected by such as, but not limited to, indoor unit combination, temperature, and pipe length.

The result can be slightly different from Product Data Book due to simulation.

Pipe lengths are estimations only.

Contractor is responsible for piping take-off and verification of actual pipe routing and pipe lengths.

EWT=Entering Water Temperature / LWT=Leaving Water Temperature.

## System Validation Check

System Name: CU2-2

**Date: 07/24/2023**

System No : 8/9

### 8. System Validation Check - General Condition

Contents	Limit	Current(Max value : connected unit)
Total pipe length	3280.8 ft	427.0 ft
Longest equivalent pipe length	574.1 ft	136.8 ft : ARNU183TQD4[FC2-18]
Longest pipe length after 1st branch	131.2 ft	107.0 ft : ARNU183TQD4[FC2-18]
Height difference [Above: IDU, Below: ODU]	360.9 ft	0.0 ft
Height difference [Above: ODU, Below: IDU]	360.9 ft	5.0 ft : ARNU363TAA4[FC2-11]
Height difference [IDU to IDU]	131.2 ft	0.0 ft : ARNU183TQD4[FC2-15]-ARNU183TQD4[FC2-15]
Longest actual pipe length	492.1 ft	127.0 ft : ARNU183TQD4[FC2-18]
Height difference [HRU to HRU]	98.4 ft	0.0 ft
Height difference [HRU to HRU connected in series (same branch)]	16.4 ft	0.0 ft
Height difference [HRU to IDU]	49.2 ft	0.0 ft

Note 1 : Except "Longest equivalent pipe length", the other pipe length limitations are actual length.

# System Tree Diagram

System Name: CU2-2

**Date: 07/24/2023**

System No : 8/9

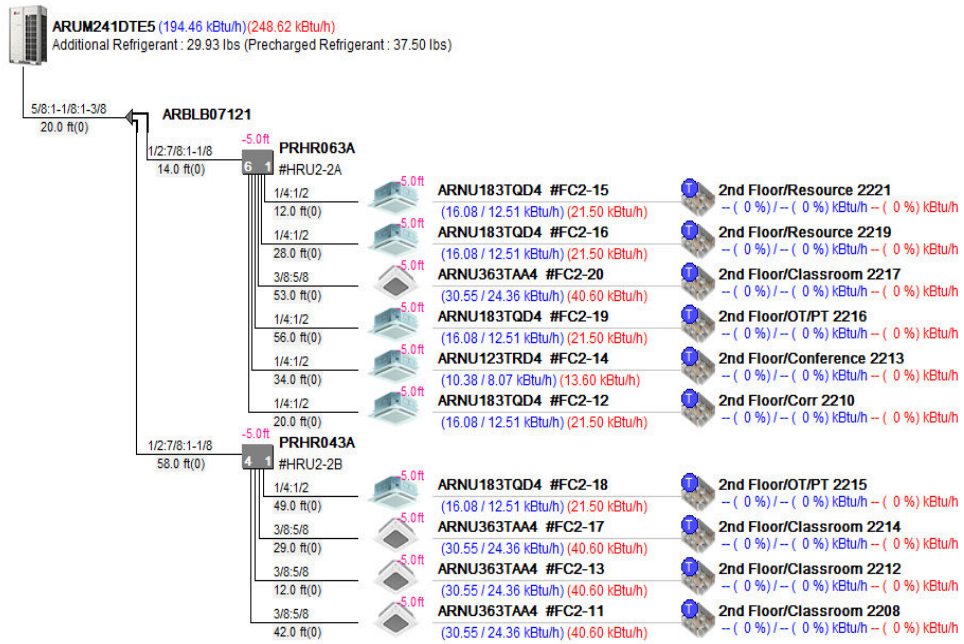

\* : Main pipe upsized  
 \*\* : Conditional Application  
**Three pipe** : Liquid : High Gas : Low Gas  
**Two pipe** : Liquid : Gas

Thermostat, 
 Group Control, 
 Dry Contact, 
 EER Kit for Multi V Indoor  
 AHU Comm. Kit [Discharge (supply) air], 
 AHU Comm. Kit [Return air]  
 AHU Comm. Kit [Main module], 
 AHU Comm. Kit [Communications module]

**Indoor Units** : 10 of 39  
**Combination Ratio** : 246.0 of 240.0 (103%)  
**Total Pipe** : 427.0 of 3280.8 ft  
**ODU factory charge** : 37.50 lbs  
**Additional Refrigerant** : 29.93 lbs  
**Total refrigerant** : 67.43 lbs  
**Minimum room volume** : 2593.56 ft³  
 (Based on 26.0 lbs / 1000.0 ft³)

# System Schematic Diagram

System Name: CU2-2

**Date: 07/24/2023**

System No : 8/9

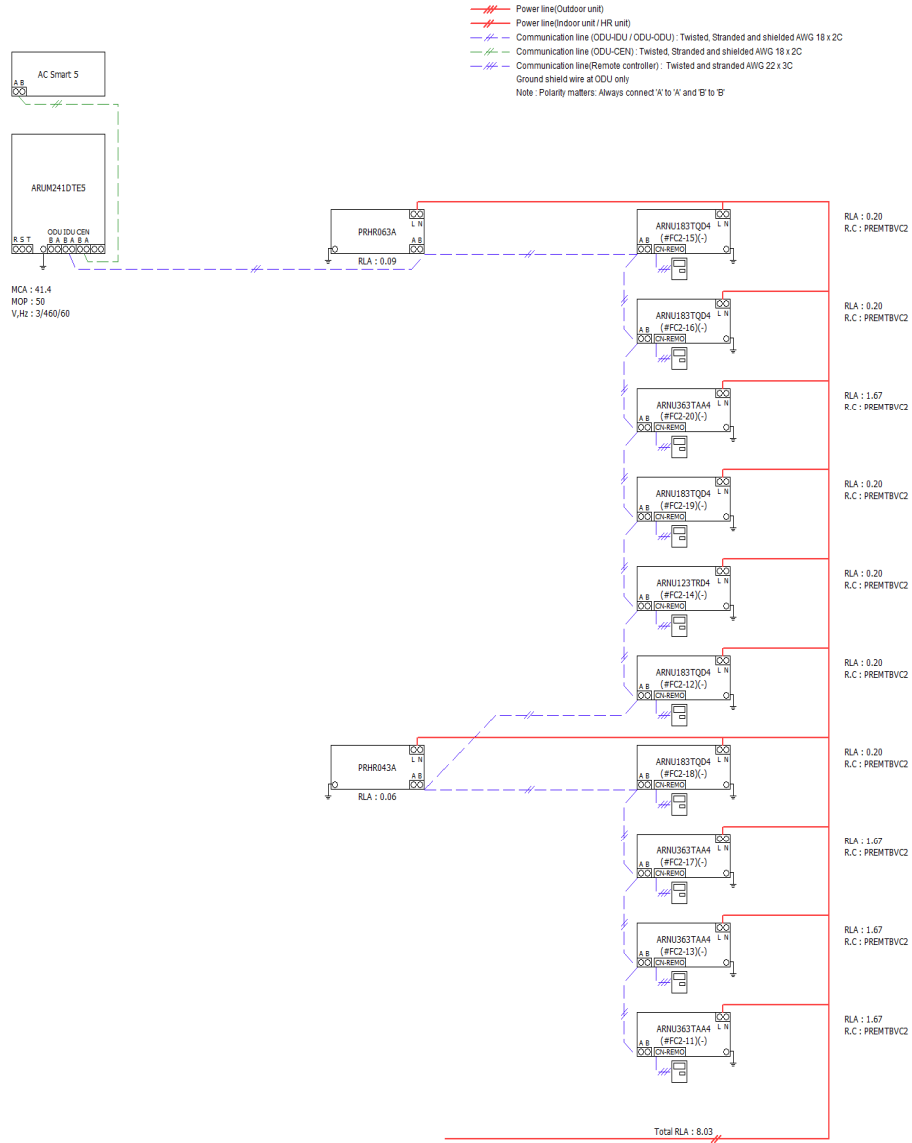

# Note :  
 Power wiring, breaker size, and disconnects should follow local code and NEC.  
 Multi-frame outdoor units require a separate power connection for each frame.  
 Refer to the most up-to-date submittal sheets for applicable electrical data.

## System Model Selection - ODU

System Name: CU2-3

**Date: 07/24/2023**

System No : 9/9

### 1. Design conditions - Outdoor

	Cooling			Heating		
	DBT(°F)	WBT(°F)	RH(%)	DBT(°F)	WBT(°F)	RH(%)
OAT	100.0	80.0	42.5	17.0	15.5	77.2
IAT	75.0	62.0	48.3	70.0	54.3	35.0

### 2. Outdoor Units

Model Name	No. of IDUs (Current / Max.) (EA)	Combination Ratio (Current / Max.) (%)	Corrected Capacity / Block Load (Cooling / Heating) (%)	Pre-charged Ref. amount (lbs)	Additional Ref. Amount (lbs)
ARUM144DTE5	5 / 24	104 / 130	0.0 / 0.0	26.50	20.56

Nominal/Corrected Capa. (kBtu/h)		Nominal/Corrected PI (kW)	
Cooling	Heating	Cooling	Heating
144.0/122.4	162.0/168.2	9.3/8.1	10.5/16.2

Efficiency(Btu/h/W)		Weight(lbs)	Dimension (WxHxD) (inch)	Electrical Characteristics				
Cooling	Heating			Volt	Phase	Hz	MCA (A)	MOP (A)
15.1	10.4	639x1	48-13/16x66-17/32x29-29/32	460	3	60	26.4	35

### 3. Pipes

Diameter(Liq:Gas,inch)	Length(ft)
1/4 : 1/2	19.0
3/8 : 5/8	171.0
1/2 : 7/8 : 1-1/8	55.0

### 4. Branch/Header

Model Name	Quantity
PRHR063A	1
-	-
-	-

#Notes: Correction factor is corrected by such as, but not limited to, indoor unit combination, temperature, and pipe length.

The result can be slightly different from Product Data Book due to simulation.

Pipe lengths are estimations only.

Contractor is responsible for piping take-off and verification of actual pipe routing and pipe lengths.

## System Model Section - IDU

System Name: CU2-3

**Date: 07/24/2023**

System No : 9/9

### 5. Indoor Units(1)

Room	Room Load(kBtu/h)			Room Design Temp.(Return Air Temp.)(°F)				Model Name	Rated TC/Corrected TC(kBtu/h)			Corrected Capa/Room Load(%)		
	TC	SC	HC	Cooling		Heating			TC	SC	HC	TC	SC	HC
				DBT	WBT	DBT	WBT							
2nd Floor/Classroom 2109	-	-	-	75.0	62.0	70.0	54.3	ARNU363TAA4	36.2/30.5	26.8/24.4	40.6/40.6	-	-	-
2nd Floor/Classroom 2110	-	-	-	75.0	62.0	70.0	54.3	ARNU363TAA4	36.2/30.5	26.8/24.4	40.6/40.6	-	-	-
2nd Floor/Classroom 2112	-	-	-	75.0	62.0	70.0	54.3	ARNU363TAA4	36.2/30.5	26.8/24.4	40.6/40.6	-	-	-
2nd Floor/Corridor 2113	-	-	-	75.0	62.0	70.0	54.3	ARNU183TQD4	19.1/16.1	13.8/12.5	21.5/21.5	-	-	-
2nd Floor/Instructional Multi Purpose 2114	-	-	-	75.0	62.0	70.0	54.3	ARNU243TAA4	24.2/20.4	19.6/17.8	27.3/27.3	-	-	-

#Notes: Correction factor is corrected by such as, but not limited to, indoor unit combination, temperature, and pipe length.

The result can be slightly different from Product Data Book due to simulation.

Pipe lengths are estimations only.

Contractor is responsible for piping take-off and verification of actual pipe routing and pipe lengths.

EWT=Entering Water Temperature / LWT=Leaving Water Temperature.

## System Model Section - IDU

System Name: CU2-3

**Date: 07/24/2023**

System No : 9/9

### 6. Indoor Units(2)

Tag	Model Name	Type	Est. Discharge Temp.(°F)		Air flow rate (CFM)	Remark
			Cooling	Heating		
FC2-21	ARNU363TAA4	DUALVANE CST 4WAY	53.2	106.9	988.0	NA
FC2-22	ARNU363TAA4	DUALVANE CST 4WAY	53.2	106.9	988.0	NA
FC2-23	ARNU363TAA4	DUALVANE CST 4WAY	53.2	106.9	988.0	NA
FC2-25	ARNU183TQD4	CASSETTE 4WAY	47.0	118.7	395.5	NA
FC2-24	ARNU243TAA4	DUALVANE CST 4WAY	55.6	100.1	813.0	NA

#Notes: Correction factor is corrected by such as, but not limited to, indoor unit combination, temperature, and pipe length.

The result can be slightly different from Product Data Book due to simulation.

Pipe lengths are estimations only.

Contractor is responsible for piping take-off and verification of actual pipe routing and pipe lengths.

EWT=Entering Water Temperature / LWT=Leaving Water Temperature.

## System Model Section - IDU

System Name: CU2-3

**Date: 07/24/2023**

System No : 9/9

### 7. Indoor Units(3)

Tag	Model Name	Weight	Dimension (WxHxD)	Electrical Characteristics				
				Volt	Phase	Hz	MCA (A)	RLA (A)
FC2-21	ARNU363TAA4	59.5 lbs	33-1/16x11-11/32x33-1/16 inch	208~230	1	60	2.09	1.67
FC2-22	ARNU363TAA4	59.5 lbs	33-1/16x11-11/32x33-1/16 inch	208~230	1	60	2.09	1.67
FC2-23	ARNU363TAA4	59.5 lbs	33-1/16x11-11/32x33-1/16 inch	208~230	1	60	2.09	1.67
FC2-25	ARNU183TQD4	35 lbs	22-7/16x10x22-7/16 inch	208~230	1	60	0.25	0.2
FC2-24	ARNU243TAA4	59.5 lbs	33-1/16x11-11/32x33-1/16 inch	208~230	1	60	2.09	1.67

#Notes: Correction factor is corrected by such as, but not limited to, indoor unit combination, temperature, and pipe length.

The result can be slightly different from Product Data Book due to simulation.

Pipe lengths are estimations only.

Contractor is responsible for piping take-off and verification of actual pipe routing and pipe lengths.

EWT=Entering Water Temperature / LWT=Leaving Water Temperature.

## System Validation Check

System Name: CU2-3

**Date: 07/24/2023**

System No : 9/9

### 8. System Validation Check - General Condition

Contents	Limit	Current(Max value : connected unit)
Total pipe length	3280.8 ft	245.0 ft
Longest equivalent pipe length	574.1 ft	136.2 ft : ARNU363TAA4[FC2-21]
Longest pipe length after 1st branch	131.2 ft	73.0 ft : ARNU363TAA4[FC2-21]
Height difference [Above: IDU, Below: ODU]	360.9 ft	0.0 ft
Height difference [Above: ODU, Below: IDU]	360.9 ft	5.0 ft : ARNU183TQD4[FC2-25]
Height difference [IDU to IDU]	131.2 ft	0.0 ft : ARNU243TAA4[FC2-24]-ARNU243TAA4[FC2-24]
Longest actual pipe length	492.1 ft	128.0 ft : ARNU363TAA4[FC2-21]
Height difference [HRU to HRU]	98.4 ft	0.0 ft
Height difference [HRU to HRU connected in series (same branch)]	16.4 ft	0.0 ft
Height difference [HRU to IDU]	49.2 ft	0.0 ft

Note 1 : Except "Longest equivalent pipe length", the other pipe length limitations are actual length.

# System Tree Diagram

System Name: CU2-3

Date: 07/24/2023

System No : 9/9



- \* : Main pipe upsized
- \*\* : Conditional Application

**Three pipe** : Liquid : High Gas : Low Gas  
**Two pipe** : Liquid : Gas

T Thermostat, G Group Control, D Dry Contact, E EEV Kit for Multi V Indoor  
S AHU Comm. Kit [Discharge (supply) air], R AHU Comm. Kit [Return air]  
M AHU Comm. Kit [Main module], C AHU Comm. Kit [Communications module]

**Indoor Units**  
 Combination Ratio : 5 of 24  
 Total Pipe : 150.0 of 144.0 (104%)  
 ODU factory charge : 245.0 of 3280.8 ft  
 Additional Refrigerant : 26.50 lbs  
 Total refrigerant : 20.56 lbs  
 Minimum room volume : 47.06 lbs  
 (Based on 26.0 lbs / 1000.0 ft³)

# System Schematic Diagram

System Name: CU2-3

Date: **07/24/2023**

System No : 9/9

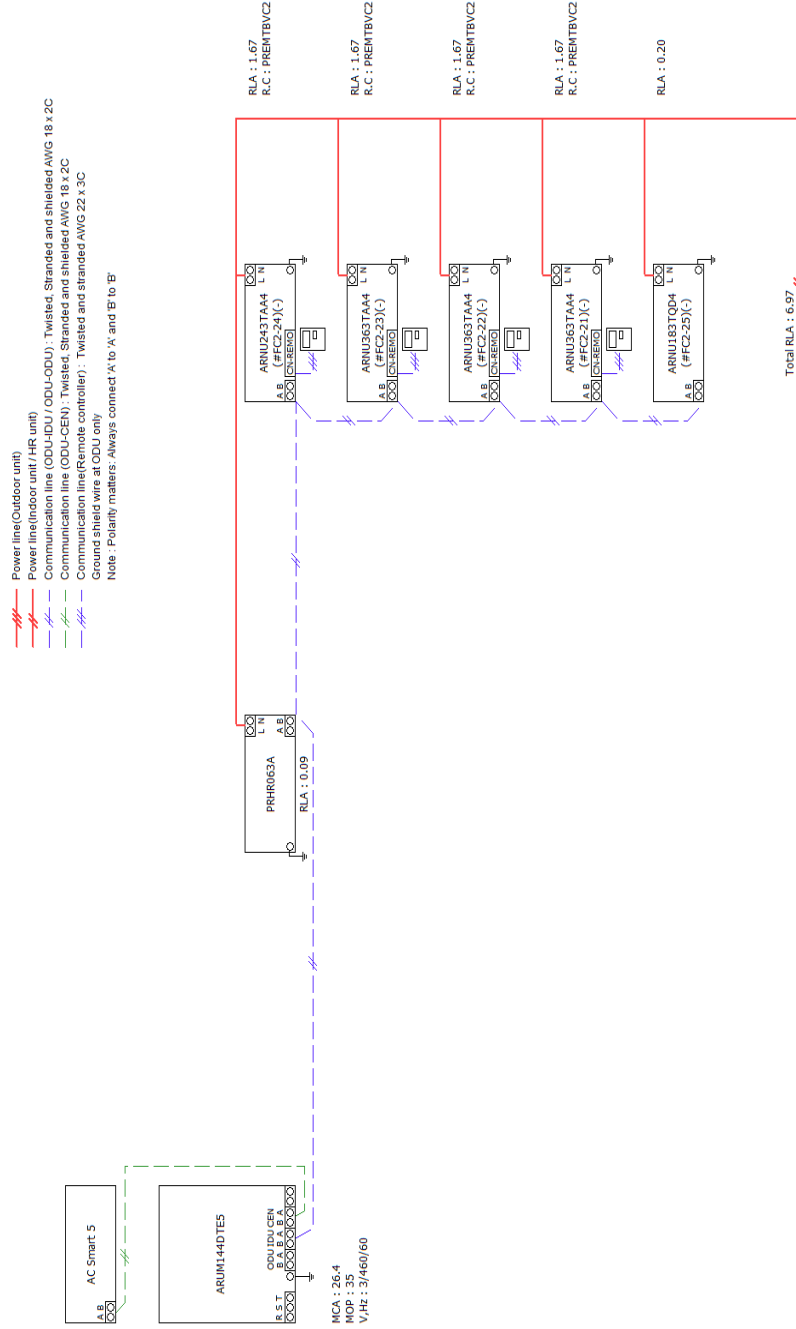

# Note :  
Power wiring, breaker size, and disconnects should follow local code and NEC.  
Multi-frame outdoor units require a separate power connection for each frame.  
Refer to the most up-to-date submittal sheets for applicable electrical data.

# Oil Trap Requirement

**Date: 07/24/2023**

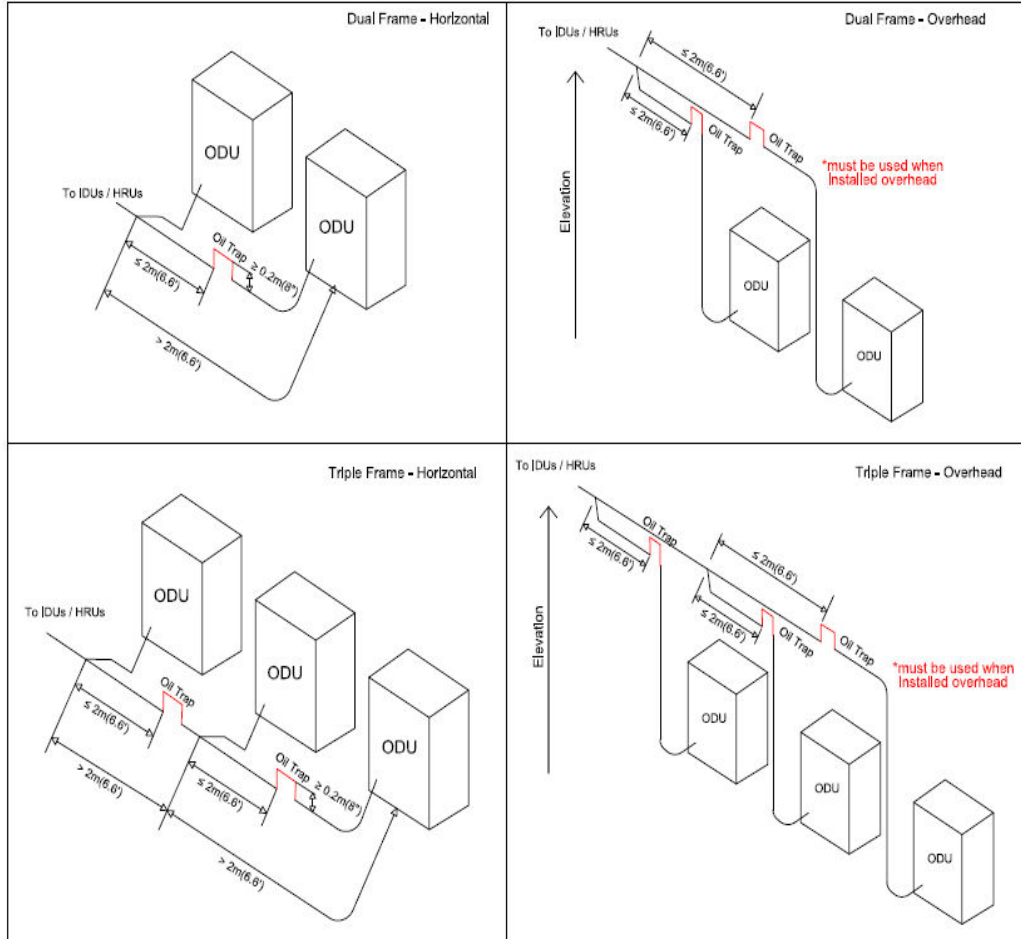

**Oil trap required:**

- Overhead piping (Water case)
- Horizontal piping when distance between the frame and connecting Y-branch exceeds 2 m (6.6 ft).
- High Gas and Low Gas pipes only
- Oil trap must be minimum 0.2 m (8 inch) high, 0.2 m (8 inch) wide.
- Oil trap must be located close to connecting Y-branch (no farther than 2 m (6.6 ft)).
- Connecting Y-branch must be installed horizontally.

**Date:** 7/24/2023

**For:**  File  Resubmit

**PO No.:**

Approval  Other\_\_\_\_\_

**Architect:** Lewis Architects and Engineers

**GC:** TBD

**Engr:** Lewis Architects and Engineers

**Mech:** Comfort Systems USA

**Rep:** Airetech Corporation  
(Company)

Nick Moore  
(Project Manager)



**ARNU093TRD4**  
Multi V™ Four-Way 2' x 2' Ceiling Cassette  
9,600 Btu/h Indoor Unit

**Performance:**

Cooling Capacity (Btu/h) <sup>1</sup>	9,600
Heating Capacity (Btu/h) <sup>1</sup>	10,900
L/M/H Power Input at Factory Default (W)	12 / 13 / 14

Rated capacity is certified under AHRI Standard 1230. Ratings are subject to change without notice. Current certified ratings are available at [www.ahridirectory.org](http://www.ahridirectory.org).

**Electrical:**

Power Supply (V/Hz/Ø)	208-230/60/1
Rated Amps	0.20

**Piping:**

<b>Refrigerant</b>	
Liquid Line (in., O.D.)	1/4 Flare
Vapor Line (in., O.D.)	1/2 Flare
<b>Condensate</b>	
Condensate Line (in., I.D.)	1
Factory Installed Pump <sup>3</sup>	Yes

**Controls Features:**

- Auto changeover (Heat Recovery only)
- Auto operation
- Auto restart
- Dual thermistor control
- Dual setpoint control
- Timer (on/off)
- Weekly schedule
- Auto direction/ swing (up/down)
- Swirl wind (alternating vanes)
- Fan speed control
- Jet cool (fast cooling)
- Filter life display
- Multiple auxiliary heater applications
- Child lock
- Group control
- High ceiling
- Hot start
- Self diagnostics
- External on/off control
- Wi-Fi compatible
- Auto fan
- Leak detection

**Required Accessories:**

- Grille Kit (24-7/16" x 24-7/16") - PT-QCHW0

**Optional Accessories:**

- Wireless Remote Controller - PQWRHQ0FDB
- MultiSITE™ CRC1 Controller - PREMTBVC0
- MultiSITE CRC1+ Controller - PREMTBVC1
- Simple Remote Controller - PREMT00U
- Premium Remote Controller - PREMTA000
- Remote Temperature Button Sensor - ZRTBS01
- Simple Dry Contact (1 contact, 24 VAC external power) - PDRYCB100
- Dry Contact for Third Party Thermostat - PDRYCB320
- Dry Contact for Economizer - PDRYCB400
- Ventilation Kit - PTVK430
- Auxiliary Heater Kit - PRARH1
- Wi-Fi Module - PWFMD200

**Entering Mixed Air:**

Cooling Maximum <sup>1</sup> (°F WB)	76
Heating Minimum (°F DB)	59

**Unit Data:**

Refrigerant Type	R410A
Refrigerant Control	EEV
Sound Pressure dB(A) (H/M/L) <sup>3</sup>	30 / 29 / 27
Primary Filter Type	Washable
Unit Net Weight (lbs.)	32
Unit Shipping Weight (lbs.)	38
Grille Net Weight (lbs.)	7
Grille Shipping Weight (lbs.)	11

**Fan:**

Type	Turbo
Quantity	1
Motor/Drive	Brushless Digitally Controlled/Direct
Motor Quantity	1
Air Flow Rate H/M/L (CFM)	283 / 265 / 251

**Notes:**

1. See Engineering Manual for sensible and latent capacities.
2. Maximum lift is 27-1/2 inches from bottom of unit.
3. Sound Pressure levels are tested in an anechoic chamber under ISO Standard 3745.
4. Communication cable between Main outdoor units to indoor units / heat recovery units to be 18 AWG, 2-conductor, twisted, stranded, shielded. Ensure the communication cable shield is properly grounded to the Main outdoor unit chassis only. Do not ground the outdoor unit to indoor units / heat recovery units communication cable at any other point. Wiring must comply with all applicable local and national codes.
5. Power wiring is field provided, and must comply with the applicable local and national codes.
6. This unit comes with a dry nitrogen charge.
7. All capacities are net with a combination ratio between 95 – 105%.
8. Must follow installation instructions in the applicable LG installation manual.



# ARNU093TRD4

## Multi V™ Four-Way 2' x 2' Ceiling Cassette

9,600 Btu/h Indoor Unit

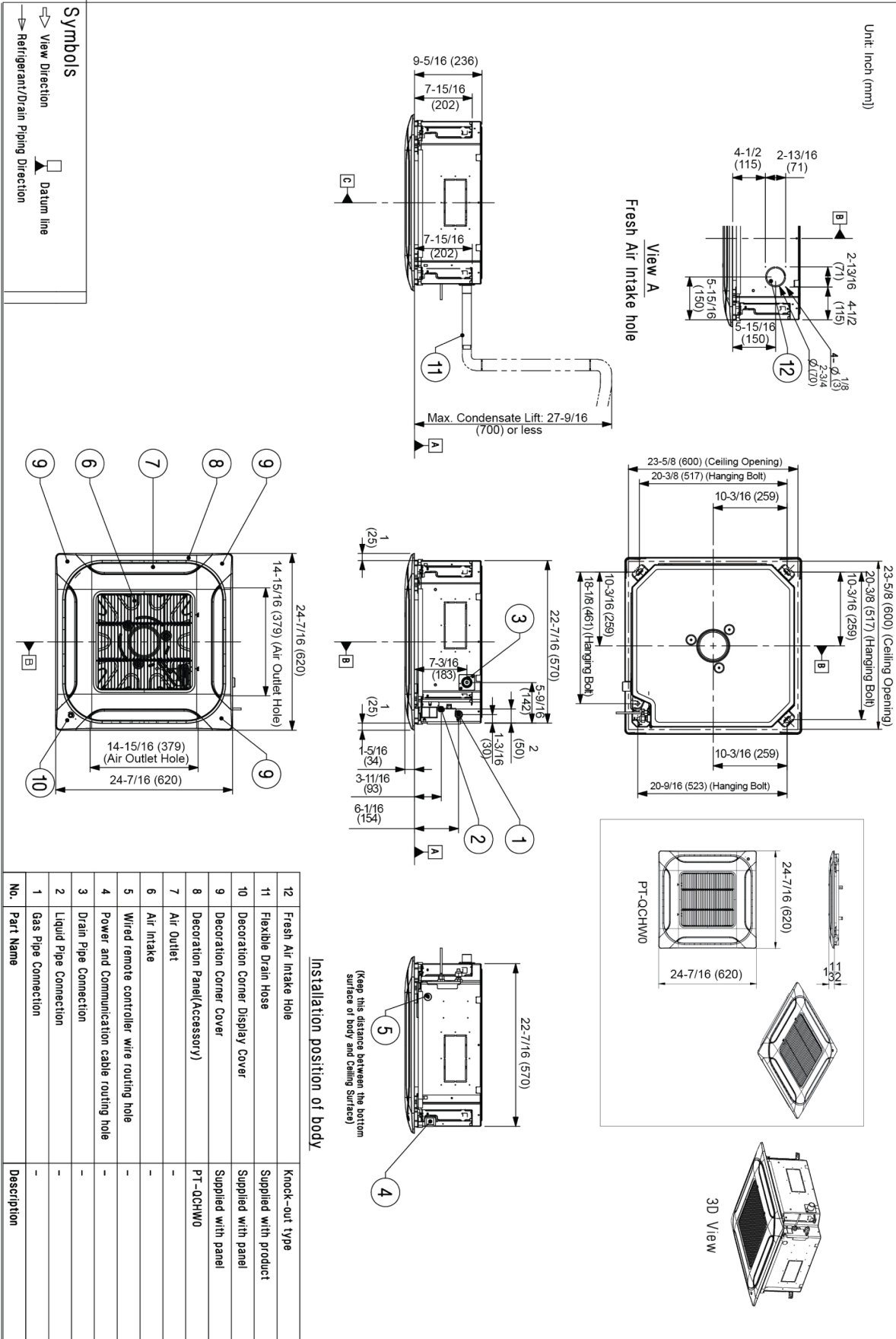

**Job Name/Location:** Southside HS and Jr High Additions

**Date:** 7/24/2023

**For:**  File  Resubmit

Approval  Other\_\_\_\_\_

**PO No.:**

**Architect:** Lewis Architects and Engineers

**GC:** TBD

**Engr:** Lewis Architects and Engineers

**Mech:** Comfort Systems USA

**Rep:** Airetech Corporation  
(Company)

Nick Moore  
(Project Manager)



**ARNU123TRD4**  
Multi V™ Four-Way 2' x 2' Ceiling Cassette  
12,300 Btu/h Indoor Unit

**Performance:**

Cooling Capacity (Btu/h) <sup>1</sup>	12,300
Heating Capacity (Btu/h) <sup>1</sup>	13,600
L/M/H Power Input at Factory Default (W)	13 / 15 / 17

Rated capacity is certified under AHRI Standard 1230. Ratings are subject to change without notice. Current certified ratings are available at [www.ahridirectory.org](http://www.ahridirectory.org).

**Electrical:**

Power Supply (V/Hz/Ø)	208-230/60/1
Rated Amps	0.20

**Piping:**

<b>Refrigerant</b>	
Liquid Line (in., O.D.)	1/4 Flare
Vapor Line (in., O.D.)	1/2 Flare
<b>Condensate</b>	
Condensate Line (in., I.D.)	1
Factory Installed Pump <sup>3</sup>	Yes

**Controls Features:**

- Auto changeover (Heat Recovery only)
- Auto operation
- Auto restart
- Dual thermistor control
- Dual setpoint control
- Timer (on/off)
- Weekly schedule
- Auto direction/ swing (up/down)
- Swirl wind (alternating vanes)
- Fan speed control
- Jet cool (fast cooling)
- Filter life display
- Multiple auxiliary heater applications
- Child lock
- Group control
- High ceiling
- Hot start
- Self diagnostics
- External on/off control
- Wi-Fi compatible
- Auto fan
- Leak detection

**Required Accessories:**

- Grille Kit (24-7/16" x 24-7/16") - PT-QCHW0

**Optional Accessories:**

- Wireless Remote Controller - PQWRHQ0FDB
- MultiSITE™ CRC1 Controller - PREMTBVC0
- MultiSITE CRC1+ Controller - PREMTBVC1
- Simple Remote Controller - PREMT00U
- Premium Remote Controller - PREMTA000
- Remote Temperature Button Sensor - ZRTBS01
- Simple Dry Contact (1 contact, 24 VAC external power) - PDRYCB100
- Dry Contact for Third Party Thermostat - PDRYCB320
- Dry Contact for Economizer - PDRYCB400
- Ventilation Kit - PTVK430
- Auxiliary Heater Kit - PRARH1
- Wi-Fi Module - PWFMD200

**Entering Mixed Air:**

Cooling Maximum <sup>1</sup> (°F WB)	76
Heating Minimum (°F DB)	59

**Unit Data:**

Refrigerant Type	R410A
Refrigerant Control	EEV
Sound Pressure dB(A) (H/M/L) <sup>3</sup>	32 / 30 / 27
Primary Filter Type	Washable
Unit Net Weight (lbs.)	32
Unit Shipping Weight (lbs.)	38
Grille Net Weight (lbs.)	7
Grille Shipping Weight (lbs.)	11

**Fan:**

Type	Turbo
Quantity	1
Motor/Drive	Brushless Digitally Controlled/Direct
Motor Quantity	1
Air Flow Rate H/M/L (CFM)	307 / 283 / 247

**Notes:**

1. See Engineering Manual for sensible and latent capacities.
2. Maximum lift is 27-1/2 inches from bottom of unit.
3. Sound Pressure levels are tested in an anechoic chamber under ISO Standard 3745.
4. Communication cable between Main outdoor units to indoor units / heat recovery units to be 18 AWG, 2-conductor, twisted, stranded, shielded. Ensure the communication cable shield is properly grounded to the Main outdoor unit chassis only. Do not ground the outdoor unit to indoor units / heat recovery units communication cable at any other point. Wiring must comply with all applicable local and national codes.
5. Power wiring is field provided, and must comply with the applicable local and national codes.
6. This unit comes with a dry nitrogen charge.
7. All capacities are net with a combination ratio between 95 – 105%.
8. Must follow installation instructions in the applicable LG installation manual.



# ARNU123TRD4

## Multi V™ Four-Way 2' x 2' Ceiling Cassette

12,300 Btu/h Indoor Unit

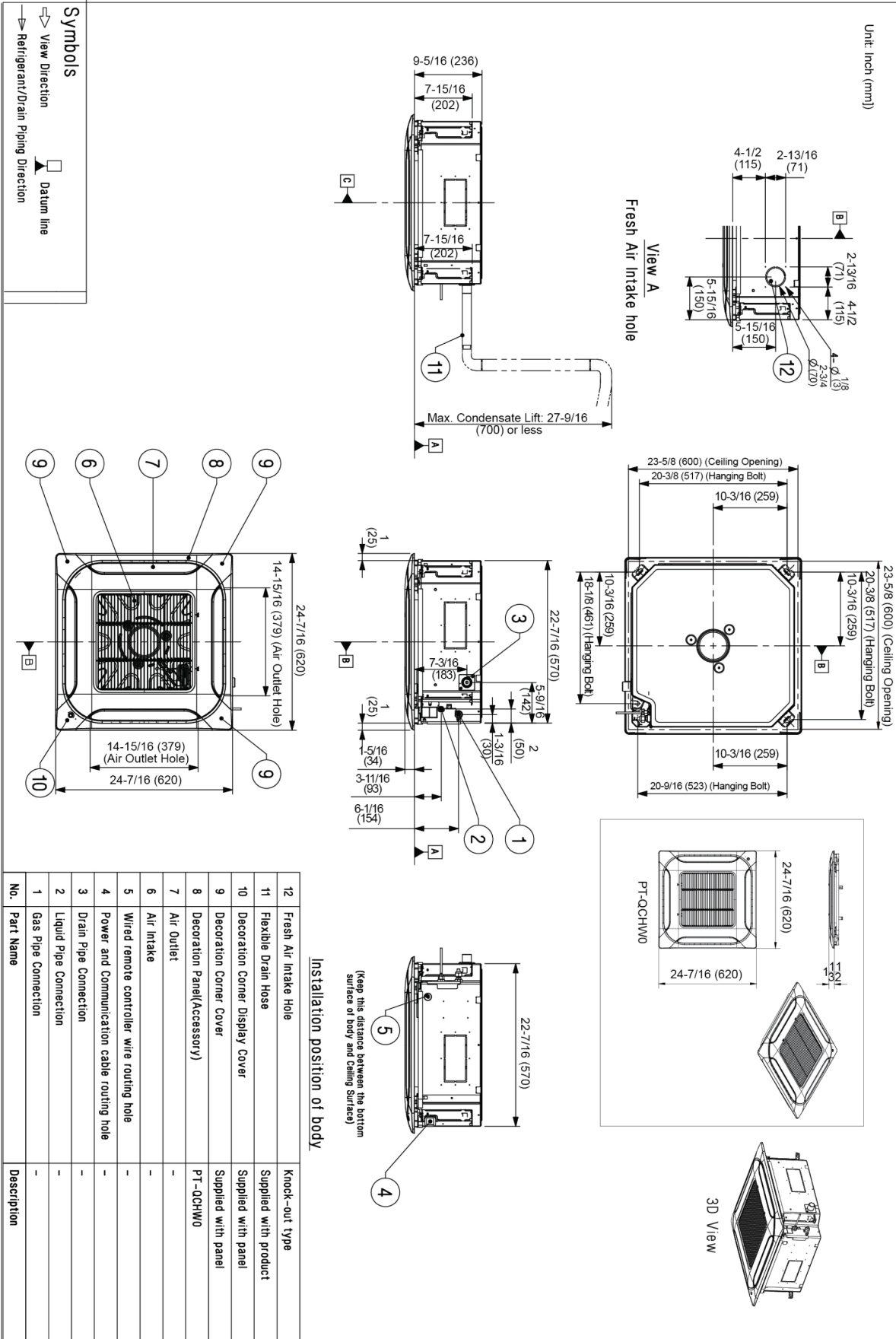

**Job Name/Location:** Southside HS and Jr High Additions

**Tag No.:** FC1-5,1-13,1-14,1-15,1-33,  
1-19,1-17,1-16,1-24,1-28,1-38,  
1-34,1-40,2-15,2-16,2-19,2-12,  
2-18,2-25

**Date:** 7/24/2023

**For:**  File  Resubmit  
 Approval  Other\_\_\_\_\_

**PO No.:**

**Architect:** Lewis Architects and Engineers

**GC:** TBD

**Engr:** Lewis Architects and Engineers

**Mech:** Comfort Systems USA

**Rep:** Airetech Corporation  
(Company)

Nick Moore  
(Project Manager)



**ARNU183TQD4**  
Multi V™ Four-Way 2' x 2' Ceiling Cassette  
19,100 Btu/h Indoor Unit

**Performance:**

Cooling Capacity (Btu/h) <sup>1</sup>	19,100
Heating Capacity (Btu/h) <sup>1</sup>	21,500
L/M/H Power Input at Factory Default (W)	19 / 22 / 25

Rated capacity is certified under AHRI Standard 1230. Ratings are subject to change without notice. Current certified ratings are available at [www.ahridirectory.org](http://www.ahridirectory.org).

**Electrical:**

Power Supply (V/Hz/Ø)	208-230/60/1
Rated Amps	0.20

**Piping:**

Refrigerant	
Liquid Line (in., O.D.)	1/4 Flare
Vapor Line (in., O.D.)	1/2 Flare
Condensate	
Condensate Line (in., I.D.)	1
Factory Installed Pump <sup>3</sup>	Yes

**Controls Features:**

- Auto changeover (Heat Recovery only)
- Auto operation
- Auto restart
- Dual thermistor control
- Dual setpoint control
- Timer (on/off)
- Weekly schedule
- Auto direction/ swing (up/down)
- Swirl wind (alternating vanes)
- Fan speed control
- Jet cool (fast cooling)
- Filter life display
- Multiple auxiliary heater applications
- Child lock
- Group control
- High ceiling
- Hot start
- Self diagnostics
- External on/off control
- Wi-Fi compatible
- Auto fan
- Leak detection

**Required Accessories:**

- Grille Kit (24-7/16" x 24-7/16") - PT-QCHW0

**Optional Accessories:**

- Wireless Remote Controller - PQWRHQ0FDB
- MultiSITE™ CRC1 Controller - PREMTBVC0
- MultiSITE CRC1+ Controller - PREMTBVC1
- Simple Remote Controller - PREMT00U
- Premium Remote Controller - PREMTA000
- Remote Temperature Button Sensor - ZRTBS01
- Simple Dry Contact (1 contact, 24 VAC external power) - PDRYCB100
- Dry Contact for Third Party Thermostat - PDRYCB320
- Dry Contact for Economizer - PDRYCB400
- Ventilation Kit - PTVK430
- Auxiliary Heater Kit - PRARH1
- Wi-Fi Module - PWFMD200

**Entering Mixed Air:**

Cooling Maximum <sup>1</sup> (°F WB)	76
Heating Minimum (°F DB)	59

**Unit Data:**

Refrigerant Type	R410A
Refrigerant Control	EEV
Sound Pressure dB(A) (H/M/L) <sup>3</sup>	37 / 35 / 34
Primary Filter Type	Washable
Unit Net Weight (lbs.)	35
Unit Shipping Weight (lbs.)	40
Grille Net Weight (lbs.)	7
Grille Shipping Weight (lbs.)	11

**Fan:**

Type	Turbo
Quantity	1
Motor/Drive	Brushless Digitally Controlled/Direct
Motor Quantity	1
Air Flow Rate H/M/L (CFM)	396 / 388 / 353

**Notes:**

1. See Engineering Manual for sensible and latent capacities.
2. Maximum lift is 27-1/2 inches from bottom of unit.
3. Sound Pressure levels are tested in an anechoic chamber under ISO Standard 3745.
4. Communication cable between Main outdoor units to indoor units / heat recovery units to be 18 AWG, 2-conductor, twisted, stranded, shielded. Ensure the communication cable shield is properly grounded to the Main outdoor unit chassis only. Do not ground the outdoor unit to indoor units / heat recovery units communication cable at any other point. Wiring must comply with all applicable local and national codes.
5. Power wiring is field provided, and must comply with the applicable local and national codes.
6. This unit comes with a dry nitrogen charge.
7. All capacities are net with a combination ratio between 95 – 105%.
8. Must follow installation instructions in the applicable LG installation manual.



# ARNU183TQD4

## Multi V™ Four-Way 2' x 2' Ceiling Cassette

19,100 Btu/h Indoor Unit

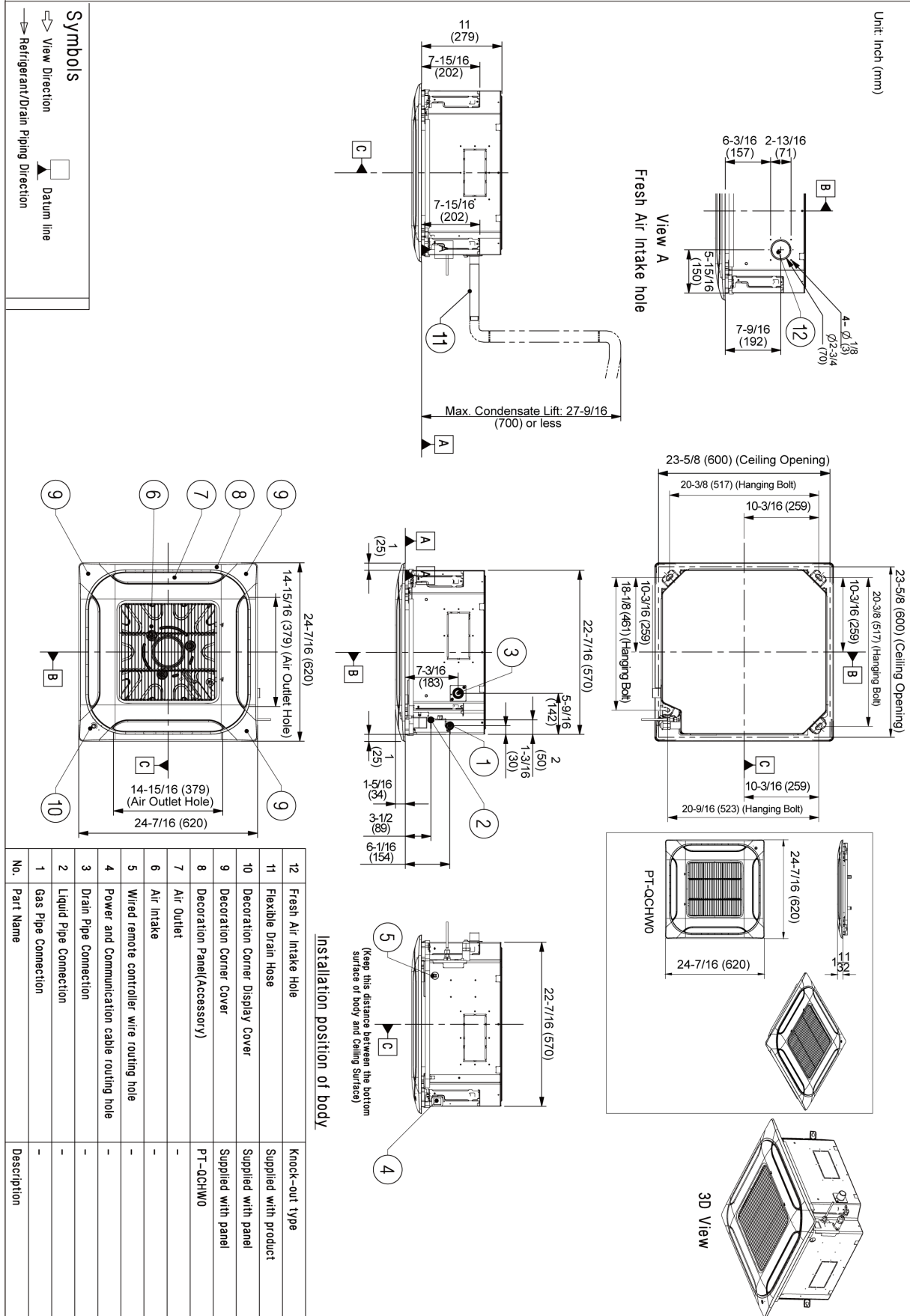

**Job Name/Location:** Southside HS and Jr High Additions

**Date:** 7/24/2023

**For:**  File  Resubmit  
 Approval  Other\_\_\_\_\_

**PO No.:**

**Architect:** Lewis Architects and Engineers

**GC:** TBD

**Engr:** Lewis Architects and Engineers

**Mech:** Comfort Systems USA

**Rep:** Airetech Corporation  
 (Company)

Nick Moore  
 (Project Manager)



**ARNU243TAA4**  
 Multi V™ Four-Way 3' x 3' Dual Vane Ceiling Cassette  
 24,200 Btu/h Indoor Unit

**Performance:**

Total Cooling Capacity (Btu/h) <sup>1</sup>	24,200
Heating Capacity (Btu/h) <sup>1</sup>	27,300
L/M/H Power Input at Factory Default (W)	24.7 / 31.1 / 40.0

Rated capacity is certified under AHRI Standard 1230. Ratings are subject to change without notice. Current certified ratings are available at [www.ahridirectory.org](http://www.ahridirectory.org).

**Piping:**

<b>Refrigerant</b>	
Liquid Line (in., O.D.)	3/8 Flare
Vapor Line (in., O.D.)	5/8 Flare
<b>Condensate</b>	
Condensate Line (in., I.D.)	1
Factory Installed Pump <sup>2</sup>	Yes

**Controls Features:**

- Auto changeover (Heat Recovery only)
- Auto operation
- Auto restart
- Dual thermistor control
- Dual setpoint control
- Timer (on/off)
- Weekly schedule
- Multiple fan operation settings
- Various airflow modes
- Fan speed control
- Jet cool (fast cooling)
- Filter life display
- Multiple auxiliary heater applications
- Child lock
- Group control
- High ceiling
- Hot start
- Self diagnostics
- External on/off control
- Wi-Fi compatible
- Auto fan
- Leak detection

**Required Accessories:**

Standard Panel - PTAAGW0

**Optional Accessories:**

- Premium Panel - PTAFGW0S (PTAFGW0 Panel + PTAHMP0 Air Purification Kit)
- Floor Temperature Sensor - PTFSMA0
- Human Detection Sensor - PTVSAA0
- Ventilation Kit - PTVK410 + PTVK420
- Ventilation Flange - PTVK430
- Wireless Remote Controller - PWLSSB21H
- MultiSITE™ CRC1 Controller - PREMTBVC0
- MultiSITE CRC1+ Controller - PREMTBVC1
- Simple Remote Controller - PREMTC00U
- Premium Remote Controller - PREMTA000
- Remote Temperature Button Sensor - ZRTBS01
- Simple Dry Contact (1 contact, 24 VAC external power) - PDRYCB100
- Dry Contact for Third-Party Thermostat - PDRYCB320<sup>4</sup>
- Dry Contact for Economizer - PDRYCB400
- Cassette Decorative Cover - PTDCA
- Auxiliary Heater Kit - PRARH1<sup>4</sup>
- Wi-Fi Module - PWFMD200

**Electrical:**

Power Supply (V/Hz/∅)	208-230/60/1
Rated Amps	1.67

**Entering Mixed Air:**

Cooling Maximum <sup>1</sup> (°F WB)	76
Heating Minimum (°F DB)	59

**Unit Data:**

Refrigerant Type	R410A
Refrigerant Control	EEV
Sound Power dB(A) (H/M/L) <sup>3</sup>	47 / 45 / 42
Standard Filter Type	Washable
Unit Net Weight (lbs.)	59.5
Unit Shipping Weight (lbs.)	71.7
Panel Net Weight (lbs.)	15.7
Panel Shipping Weight (lbs.)	20.5

**Fan:**

Type	Full 3D Turbo
Quantity	1
Motor/Drive	Brushless Digitally Controlled/Direct
Motor Quantity	1
Air Flow Rate H/M/L/LL (CFM)	813 / 742 / 670 / 576

**Notes:**

- See Engineering Manual for sensible and latent capacities.
- Maximum lift is 27-9/16 inches from bottom of unit.
- Sound power level is tested per ISO 9614 standards.
- If a Third-Party Dry Contact and an LG internal heater or an LG Auxiliary Heater Kit is installed, supplemental heat capability cannot be controlled by the Third-Party Thermostat.
- Communication cable between (main) outdoor unit to indoor units / heat recovery units to be 18 AWG, 2-conductor, twisted, stranded, shielded. Ensure the communication cable shield is properly grounded to the (main) outdoor unit chassis only. **DO NOT** ground the outdoor unit to indoor units / heat recovery units communication cable at any other point. Wiring must comply with all applicable local and national codes.
- Power wiring is field provided, and must comply with the applicable local and national codes.
- This unit comes with a dry nitrogen charge.
- All capacities are net with a combination ratio between 95 – 105%.
- Must follow installation instructions in the applicable LG installation manual.



**ARNU243TAA4**  
**Multi V™ Four-Way 3' x 3' Dual Vane Ceiling Cassette**  
 24,200 Btu/h Indoor Unit



Tag No.: \_\_\_\_\_

Date: 7/24/2023

PO No.: \_\_\_\_\_

Unit: Inch

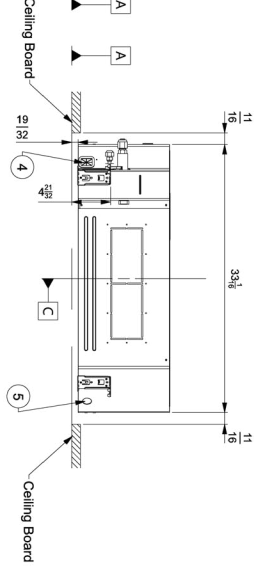
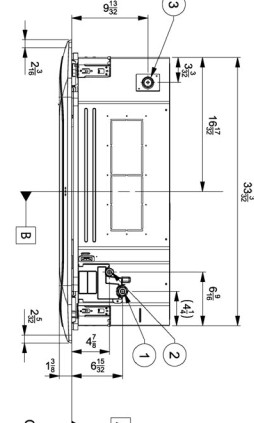
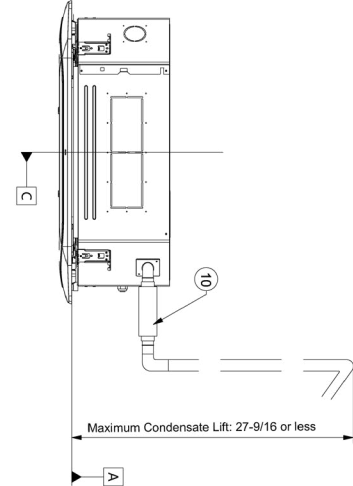
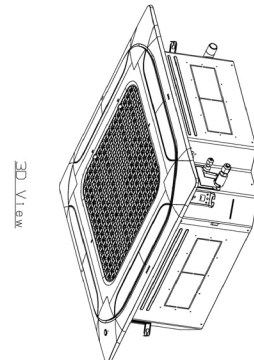
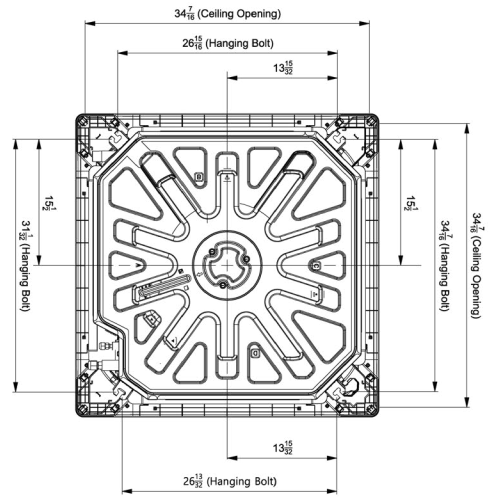
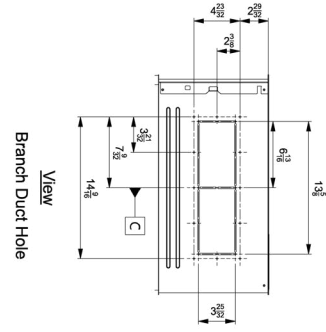

Installation Position of Frame  
 (Retain the distance shown between the bottom of the frame and the ceiling.)

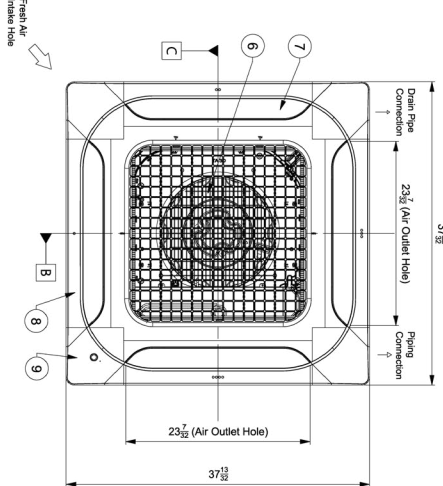
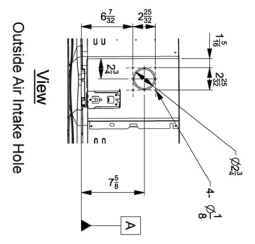

- Notes:
1. Unit must be installed in compliance with the installation manual.
  2. Unit must be grounded in accordance with the local or state regulations, and applicable national codes.
  3. All field-supplied electrical components and materials must comply with local, state, and national codes.

No.	Part Name	Description
11	Outside Air Intake Hole	Knock-out type
10	Flexible Drain Hose	Supplied with product
9	Decoration Corner Cover	Supplied with panel
8	Standard Panel (Accessory)	PTAAGW0
8	Premium Panel (Accessory)	PTAFGW05
7	Air Outlet	-
6	Air Inlet	-
5	Wired Remote Controller/Wiring Routing Hole	-
4	Power/Wiring and Communications Cable Routing Hole	-
3	Drain Pipe Connection	-
2	Liquid Pipe Connection	-
1	Gas Pipe Connection	-

**Date:** 7/24/2023

**For:**  File  Resubmit  
 Approval  Other\_\_\_\_\_

**PO No.:**

**Architect:** Lewis Architects and Engineers

**GC:** TBD

**Engr:** Lewis Architects and Engineers

**Mech:** Comfort Systems USA

**Rep:** Airetech Corporation  
 (Company)

Nick Moore  
 (Project Manager)



**ARNU283TAA4**  
 Multi V™ Four-Way 3' x 3' Dual Vane Ceiling Cassette  
 28,000 Btu/h Indoor Unit

**Performance:**

Total Cooling Capacity (Btu/h) <sup>1</sup>	28,000
Heating Capacity (Btu/h) <sup>1</sup>	31,500
L/M/H Power Input at Factory Default (W)	26.1 / 35.2 / 45.5

Rated capacity is certified under AHRI Standard 1230. Ratings are subject to change without notice. Current certified ratings are available at [www.ahridirectory.org](http://www.ahridirectory.org).

**Piping:**

<b>Refrigerant</b>	
Liquid Line (in., O.D.)	3/8 Flare
Vapor Line (in., O.D.)	5/8 Flare
<b>Condensate</b>	
Condensate Line (in., I.D.)	1
Factory Installed Pump <sup>2</sup>	Yes

**Controls Features:**

- Auto changeover (Heat Recovery only)
- Auto operation
- Auto restart
- Dual thermistor control
- Dual setpoint control
- Timer (on/off)
- Weekly schedule
- Multiple fan operation settings
- Various airflow modes
- Fan speed control
- Jet cool (fast cooling)
- Filter life display
- Multiple auxiliary heater applications
- Child lock
- Group control
- High ceiling
- Hot start
- Self diagnostics
- External on/off control
- Wi-Fi compatible
- Auto fan
- Leak detection

**Required Accessories:**

Standard Panel - PTAAGW0

**Optional Accessories:**

- Premium Panel - PTAFGW0S (PTAFGW0 Panel + PTAHMP0 Air Purification Kit)
- Floor Temperature Sensor - PTFSMA0
- Human Detection Sensor - PTVSAA0
- Ventilation Kit - PTVK410 + PTVK420
- Ventilation Flange - PTVK430
- Wireless Remote Controller - PWLSSB21H
- MultiSITE™ CRC1 Controller - PREMTBVC0
- MultiSITE CRC1+ Controller - PREMTBVC1
- Simple Remote Controller - PREMTC00U
- Premium Remote Controller - PREMTA000
- Remote Temperature Button Sensor - ZRTBS01
- Simple Dry Contact (1 contact, 24 VAC external power) - PDRYCB100
- Dry Contact for Third-Party Thermostat - PDRYCB320<sup>4</sup>
- Dry Contact for Economizer - PDRYCB400
- Cassette Decorative Cover - PTDCA
- Auxiliary Heater Kit - PRARH1<sup>4</sup>
- Wi-Fi Module - PWFMD200

**Electrical:**

Power Supply (V/Hz/ø)	208-230/60/1
Rated Amps	1.67

**Entering Mixed Air:**

Cooling Maximum <sup>1</sup> (°F WB)	76
Heating Minimum (°F DB)	59

**Unit Data:**

Refrigerant Type	R410A
Refrigerant Control	EEV
Sound Power dB(A) (H/M/L) <sup>3</sup>	48 / 46 / 42
Standard Filter Type	Washable
Unit Net Weight (lbs.)	59.5
Unit Shipping Weight (lbs.)	71.7
Panel Net Weight (lbs.)	15.7
Panel Shipping Weight (lbs.)	20.5

**Fan:**

Type	Full 3D Turbo
Quantity	1
Motor/Drive	Brushless Digitally Controlled/Direct
Motor Quantity	1
Air Flow Rate H/M/L/LL (CFM)	855 / 771 / 687 / 599

**Notes:**

1. See Engineering Manual for sensible and latent capacities.
2. Maximum lift is 27-9/16 inches from bottom of unit.
3. Sound power level is tested per ISO 9614 standards.
4. If a Third-Party Dry Contact and an LG internal heater or an LG Auxiliary Heater Kit is installed, supplemental heat capability cannot be controlled by the Third-Party Thermostat.
5. Communication cable between (main) outdoor unit to indoor units / heat recovery units to be 18 AWG, 2-conductor, twisted, stranded, shielded. Ensure the communication cable shield is properly grounded to the (main) outdoor unit chassis only. **DO NOT** ground the outdoor unit to indoor units / heat recovery units communication cable at any other point. Wiring must comply with all applicable local and national codes.
6. Power wiring is field provided, and must comply with the applicable local and national codes.
7. This unit comes with a dry nitrogen charge.
8. All capacities are net with a combination ratio between 95 – 105%.
9. Must follow installation instructions in the applicable LG installation manual.



**ARNU283TAA4**  
**Multi V™ Four-Way 3' x 3' Dual Vane Ceiling Cassette**  
 28,000 Btu/h Indoor Unit



Tag No.: \_\_\_\_\_

Date: 7/24/2023

PO No.: \_\_\_\_\_

Unit: Inch

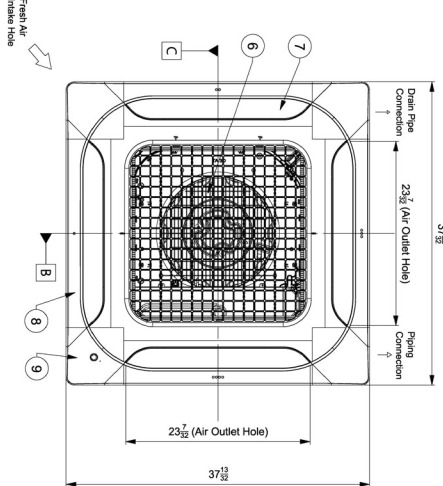
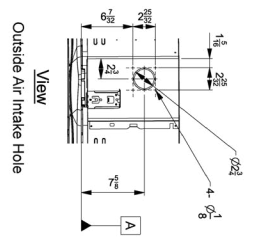
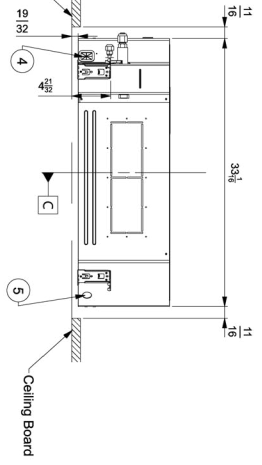
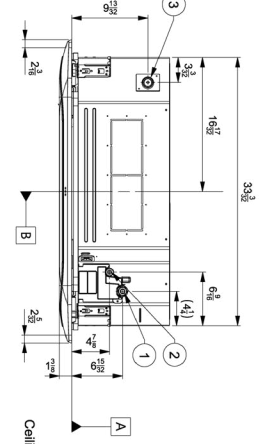
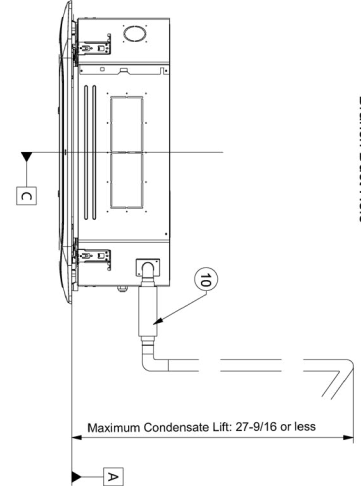
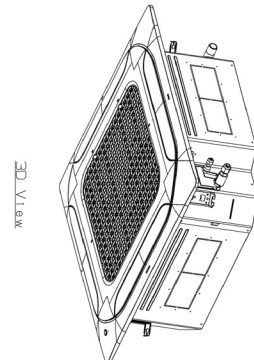
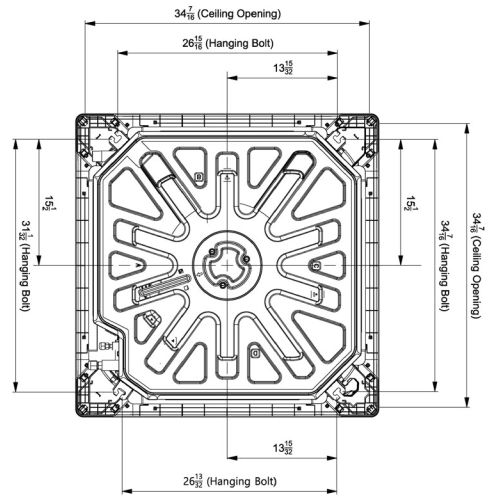
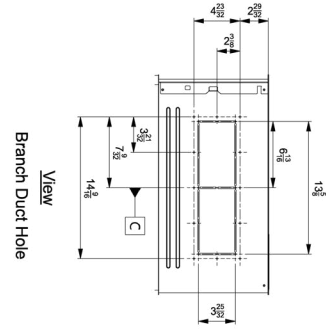

- Notes:**
1. Unit must be installed in compliance with the installation manual.
  2. Unit must be grounded in accordance with the local or state regulations, and applicable national codes.
  3. All field-supplied electrical components and materials must comply with local, state, and national codes.

No.	Part Name	Description
11	Outside Air Intake Hole	Knock-out type
10	Flexible Drain Hose	Supplied with product
9	Decoration Corner Cover	Supplied with panel
8	Standard Panel (Accessory)	PTAAGW0
8	Premium Panel (Accessory)	PTAFGW05
7	Air Outlet	-
6	Air Inlet	-
5	Wired Remote Controller/Wiring Routing Hole	-
4	Power/Wiring and Communications Cable Routing Hole	-
3	Drain Pipe Connection	-
2	Liquid Pipe Connection	-
1	Gas Pipe Connection	-

**Installation Position of Frame**  
 (Retain the distance shown between the bottom of the frame and the ceiling.)

**Job Name/Location:** Southside HS and Jr High Additions

**Tag No.:** FC1-32,1-12,1-21,1-22,1-35,  
1-44,1-43,1-41,1-42,2-5,2-7,2-6,  
2-1,2-4,2-26,2-20,2-17,2-13,  
2-11,2-23,2-22,2-21

**Date:** 7/24/2023

**For:**  File  Resubmit

**PO No.:**

Approval  Other

**Architect:** Lewis Architects and Engineers

**GC:** TBD

**Engr:** Lewis Architects and Engineers

**Mech:** Comfort Systems USA

**Rep:** Airetech Corporation

Nick Moore

(Company)

(Project Manager)

## ARNU363TAA4

Multi V™ Four-Way 3' x 3' Dual Vane Ceiling Cassette

36,200 Btu/h Indoor Unit



### Performance:

Total Cooling Capacity (Btu/h) <sup>1</sup>	36,200
Heating Capacity (Btu/h) <sup>1</sup>	40,600
L/M/H Power Input at Factory Default (W)	31.1 / 43.4 / 64.7

Rated capacity is certified under AHRI Standard 1230. Ratings are subject to change without notice. Current certified ratings are available at [www.ahridirectory.org](http://www.ahridirectory.org).

### Piping:

<b>Refrigerant</b>	
Liquid Line (in., O.D.)	3/8 Flare
Vapor Line (in., O.D.)	5/8 Flare
<b>Condensate</b>	
Condensate Line (in., I.D.)	1
Factory Installed Pump <sup>2</sup>	Yes

### Controls Features:

- Auto changeover (Heat Recovery only)
- Auto operation
- Auto restart
- Dual thermistor control
- Dual setpoint control
- Timer (on/off)
- Weekly schedule
- Multiple fan operation settings
- Various airflow modes
- Fan speed control
- Jet cool (fast cooling)
- Filter life display
- Multiple auxiliary heater applications
- Child lock
- Group control
- High ceiling
- Hot start
- Self diagnostics
- External on/off control
- Wi-Fi compatible
- Auto fan
- Leak detection

### Required Accessories:

- Standard Panel - PTAAGW0

### Optional Accessories:

- Premium Panel - PTAFGW0S (PTAFGW0 Panel + PTAHMP0 Air Purification Kit)
- Floor Temperature Sensor - PTFSMA0
- Human Detection Sensor - PTVSAA0
- Ventilation Kit - PTVK410 + PTVK420
- Ventilation Flange - PTVK430
- Wireless Remote Controller - PWLSSB21H
- MultiSITE™ CRC1 Controller - PREMTBVC0
- MultiSITE CRC1+ Controller - PREMTBVC1
- Simple Remote Controller - PREMTC00U
- Premium Remote Controller - PREMTA000
- Remote Temperature Button Sensor - ZRTBS01
- Simple Dry Contact (1 contact, 24 VAC external power) - PDRYCB100
- Dry Contact for Third-Party Thermostat - PDRYCB320<sup>4</sup>
- Dry Contact for Economizer - PDRYCB400
- Cassette Decorative Cover - PTDCA
- Auxiliary Heater Kit - PRARH1<sup>4</sup>
- Wi-Fi Module - PWFMD200

### Electrical:

Power Supply (V/Hz/∅)	208-230/60/1
Rated Amps	1.67

### Entering Mixed Air:

Cooling Maximum <sup>1</sup> (°F WB)	76
Heating Minimum (°F DB)	59

### Unit Data:

Refrigerant Type	R410A
Refrigerant Control	EEV
Sound Power dB(A) (H/M/L) <sup>3</sup>	51 / 48 / 44
Standard Filter Type	Washable
Unit Net Weight (lbs.)	59.5
Unit Shipping Weight (lbs.)	71.7
Panel Net Weight (lbs.)	15.7
Panel Shipping Weight (lbs.)	20.5

### Fan:

Type	Full 3D Turbo
Quantity	1
Motor/Drive	Brushless Digitally Controlled/Direct
Motor Quantity	1
Air Flow Rate H/M/L/LL (CFM)	988 / 838 / 735 / 653

### Notes:

1. See Engineering Manual for sensible and latent capacities.
2. Maximum lift is 27-9/16 inches from bottom of unit.
3. Sound power level is tested per ISO 9614 standards.
4. If a Third-Party Dry Contact and an LG internal heater or an LG Auxiliary Heater Kit is installed, supplemental heat capability cannot be controlled by the Third-Party Thermostat.
5. Communication cable between (main) outdoor unit to indoor units / heat recovery units to be 18 AWG, 2-conductor, twisted, stranded, shielded. Ensure the communication cable shield is properly grounded to the (main) outdoor unit chassis only. **DO NOT** ground the outdoor unit to indoor units / heat recovery units communication cable at any other point. Wiring must comply with all applicable local and national codes.
6. Power wiring is field provided, and must comply with the applicable local and national codes.
7. This unit comes with a dry nitrogen charge.
8. All capacities are net with a combination ratio between 95 – 105%.
9. Must follow installation instructions in the applicable LG installation manual.





Date: 7/24/2023

For:  File  Resubmit  
 Approval  Other\_\_\_\_\_

PO No.:

Architect: Lewis Architects and Engineers

GC: TBD

Engr: Lewis Architects and Engineers

Mech: Comfort Systems USA

Rep: Airetech Corporation  
 (Company)

Nick Moore  
 (Project Manager)

**PT-QCHW0**  
**2' x 2' Cassette Panel**

For Multi V™/Single-Zone /Multi F 4-Way Ceiling-Cassette Indoor Units



**Unit Data:**

Color	Morning Fog
Panel Assembly Dimensions (W x H x D, in.)	24-13/32 x 1-11/32 x 24-13/32
Total Net Weight (lbs.)	7
Total Shipping Weight (lbs.)	9
Display LED Color	Green
Filter	Long Life / Washable

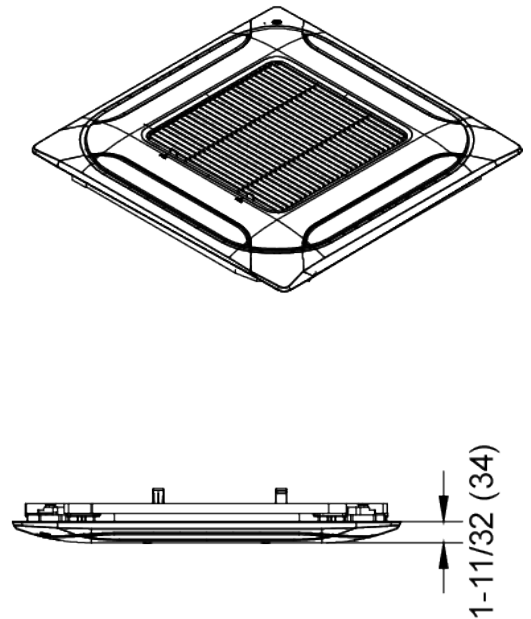
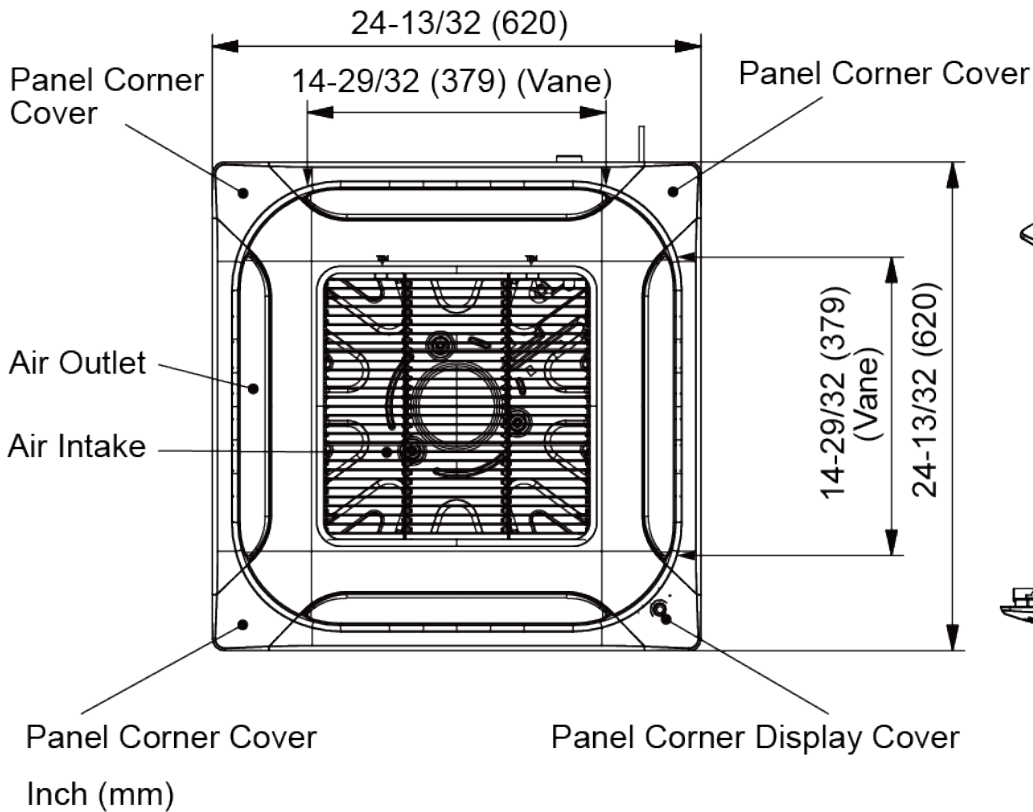

Date: 7/24/2023

For:  File  Resubmit  
 Approval  Other\_\_\_\_\_

PO No.:

Architect: Lewis Architects and Engineers

GC: TBD

Engr: Lewis Architects and Engineers

Mech: Comfort Systems USA

Rep: Airetech Corporation  
 (Company)

Nick Moore  
 (Project Manager)

## PT-AAGW0

### 3' x 3' Standard Cassette Panel

For Multi V™/Single-Zone 4-Way Dual-Vane Ceiling-Cassette Indoor Units

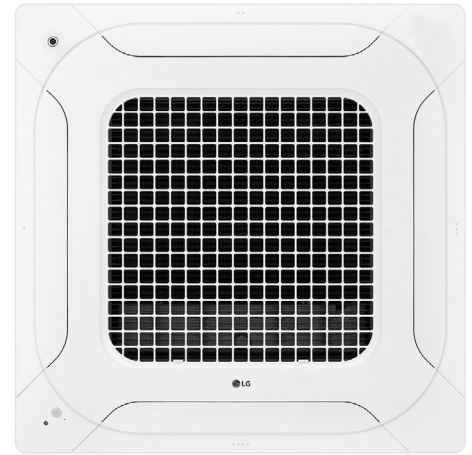

Vanes Fully Closed

Vanes Fully Opened



#### Unit Data:

Color	White
Panel Assembly Dimensions (W x H x D, in.)	37-3/8 x 1-3/8 x 37-3/8
Total Net Weight (lbs.)	16
Total Shipping Weight (lbs.)	21
Operation LED Display Colors	Green / Yellow / Orange
Filter	Long Life / Washable / MERV 6

#### Vanes Fully Closed, Side View



#### Vanes Fully Opened, Side View



#### Panel Dimensions

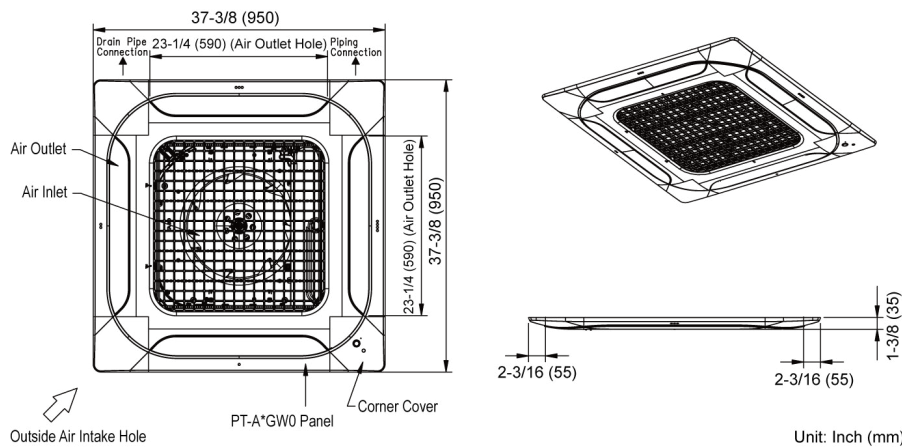

#### Component Locations

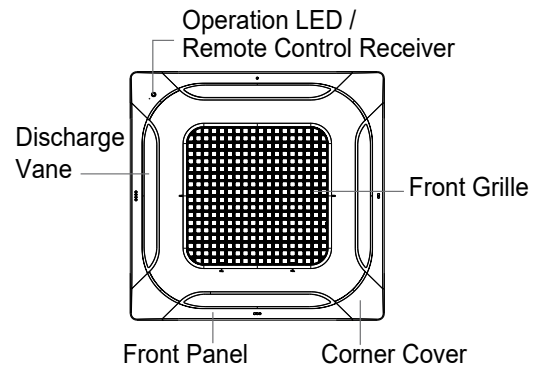

Date: 7/24/2023

For:  File  Resubmit  
 Approval  Other \_\_\_\_\_

PO No.:

Architect: Lewis Architects and Engineers

GC: TBD

Engr: Lewis Architects and Engineers

Mech: Comfort Systems USA

Rep: Airetech Corporation  
 (Company)

Nick Moore  
 (Project Manager)

**ARNU363NJA4**  
 Multi V™ Vertical /Horizontal Air Handling Unit  
 36,000 Btu/h Indoor Unit



**Performance:**

Total Cooling Capacity (Btu/h)	36,000
Heating Capacity (Btu/h)	40,000
Max Power Input <sup>1</sup> (W)	228
L/M/H Power Input at Factory Default (W)	133 / 180 / 228

Rated capacity is certified under AHRI Standard 1230. Ratings are subject to change without notice. Current certified ratings are available at [www.ahridirectory.org](http://www.ahridirectory.org).

**Electrical:**<sup>2</sup>

Power Supply (V/Hz/Ø)	208-230/60/1
Rated Amps (A)	1.12

**Piping:**

Refrigerant:

Liquid Line (in, OD)	3/8 braze
Vapor Line (in, OD)	5/8 braze

Condensate:

Condensate Line (in, ID)	1 (3/4 FPT)
Factory Installed Pump	No

**Controls Features:**

- Auto Operation
- Auto Changeover (Heat Recovery Only)
- Auto Restart
- Auto Fan
- Child Lock
- Dual Thermistor Control
- E.S.P. Control
- Group Control
- Hot Start
- Self Diagnostics
- Weekly Schedule
- Dual Setpoint Control
- Filter Life Display
- External on/off control
- Timer (On/Off)
- Fan Speed Control
- Leak Detection
- Wi-Fi Compatible

**Optional Accessories:**

- Wireless Remote Controller<sup>3</sup> - PQWRHQ0FDB
- Premium Controller - PREMTA000
- MultiSITE CRC1 Controller - PREMTBVC0
- MultiSITE CRC1+ Controller - PREMTBVC1
- Simple Controller - PREMTC00U
- Wi-Fi Module - PWFMD200
- Simple Dry Contact (1 contact, 24 VAC external power) - PDRYCB100
- Dry Contact for Economizer - PDRYCB400
- Dry Contact for Third Party Thermostat - PDRYCB320
- Electric Heat Kits - ANEHXX3B1/B2 Series
- Aux Heater Relay Kit - PRARH1
- Remote Temperature Button Sensor - ZRTBS01

**Entering Mixed Air:**

Cooling Max <sup>4</sup> (°F WB)	76
Heating Min (°F DB)	59

**Unit Data:**

Refrigerant Type	R410A
Refrigerant Control	EEV
Sound Pressure <sup>5</sup> dB(A) (H/M/L)	45 / 44 / 43
Net Unit Weight (lbs)	121
Shipping Weight (lbs)	144

**Fan:**

Type	Sirocco
Fan Quantity:	1
Motor/Drive:	Brushless Digitally Controlled/Direct
Motor Quantity:	1
High Mode Airflow Rate H/M/L (CFM):	990/880/800
High Mode External Static Pressure (ESP) <sup>6</sup> (in wg):	0.5
Standard Mode Airflow Rate H/M/L (CFM):	990/880/800
Standard Mode External Static Pressure (ESP) <sup>6</sup> (in wg):	0.3
Minimum ESP <sup>7</sup> :	0.1
Maximum ESP <sup>7</sup> :	1.0

**Standard Features:**

- Access Panel for Field Supplied Air Filter
- 16 x 20 x 1

**Notes:**

1. Maximum power input is rated at maximum setting value.
2. Electrical data listed is without an electric heat kit accessory option. The addition of an electric heat kit accessory option will change the electrical data.
3. Requires an LG wall controller because ducted units don't have an infrared receiver.
4. See Engineering Manual for sensible and latent capacities.
5. Sound pressure levels are tested in an anechoic chamber under ISO Standard 3745.
6. At factory fan speed setting.
7. Maximum static pressure may result in reduced airflow (CFM).
8. All Communication cable between Master outdoor units to indoor units / heat recovery units to be 18 AWG, 2-conductor, twisted, stranded, shielded. Ensure the communication cable shield is properly grounded to the Master outdoor unit chassis only. Do not ground the outdoor unit to indoor units / heat recovery units communication cable at any other point. Wiring must comply with all applicable local and national codes.
9. Power wiring cable size must comply with the applicable local and national code.
10. This unit comes with a dry nitrogen charge.
11. All capacities are net with a combination ratio between 95 – 105%.
12. Adjust fan speed to correct for static pressure increases when using field supplied air filter or heat kit.
13. Must follow installation instructions in the applicable LG installation manual.



**ARNU363NJA4**

Multi V™ Vertical /Horizontal Air Handling Unit

36,000 Btu/h Indoor Unit



Tag #:

Date: 7/24/2023

PO No.:

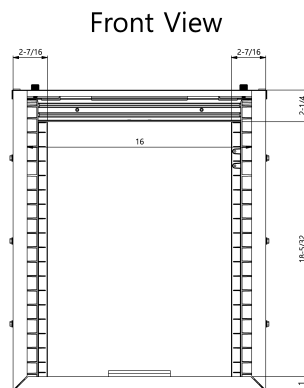
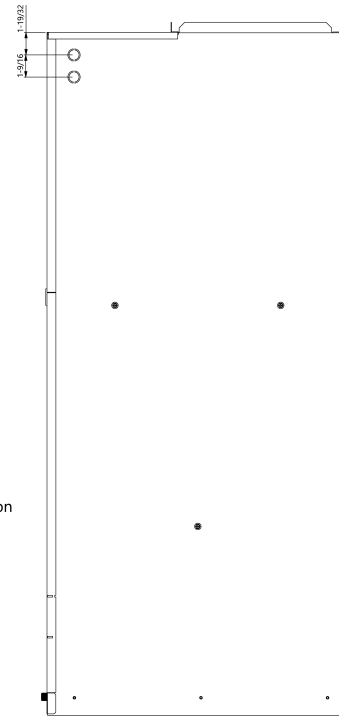
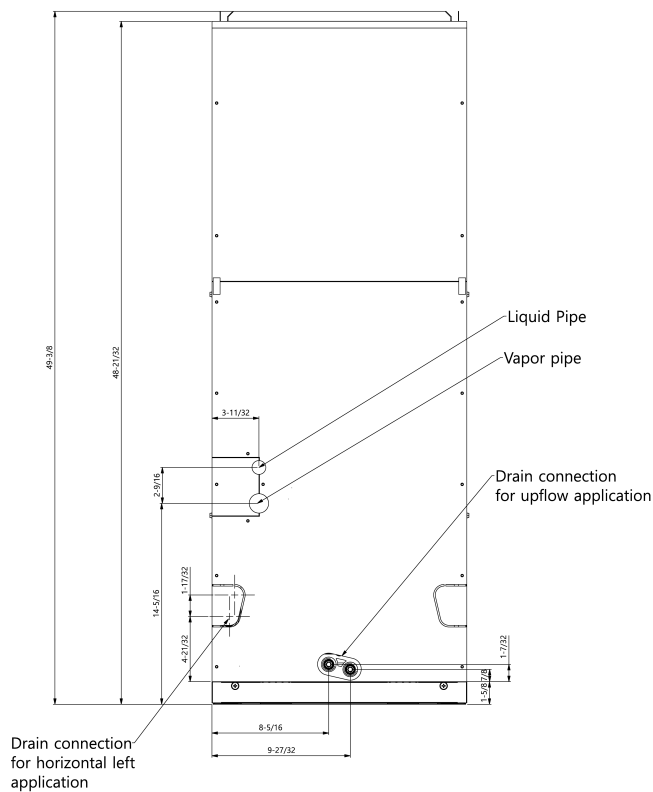
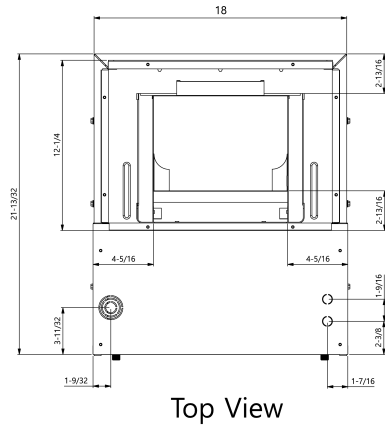

Date: 7/24/2023

For:  File  Resubmit

PO No.:

 Approval  Other

Architect: Lewis Architects and Engineers

GC: TBD

Engr: Lewis Architects and Engineers

Mech: Comfort Systems USA

Rep: Airetech Corporation

Nick Moore

(Company)

(Project Manager)

**ARNU963B8A4****Multi V™ High Static Ducted**

95,900 Btu/h Indoor Unit

**Performance:**

Total Cooling Capacity (Btu/h)	95,900
Heating Capacity (Btu/h)	107,500
Max Power Input <sup>1</sup> (W)	800
L/M/H Power Input at Factory Default (W)	750 / 750 / 800

Rated capacity is certified under AHRI Standard 1230. Ratings are subject to change without notice. Current certified ratings are available at [www.ahridirectory.org](http://www.ahridirectory.org).

**Electrical:**

Power Supply (V/Hz/Ø)	208-230/60/1
Rated Amps (A)	5.2

**Piping:**

## Refrigerant:

Liquid Line (in, OD) <sup>14</sup>	3/8 Braze
Vapor Line (in, OD)	7/8 Braze

## Condensate:

Condensate Pump Drain <sup>2</sup> (in, ID)	1 Plain
Gravity Drain Plugged (in, OD)	1 (3/4 MPT)

**Controls Features:**

- Auto changeover (Heat Recovery only)
- Auto operation
- Auto restart
- Dual thermistor control
- Wi-Fi compatible
- Dual setpoint control
- Multiple aux heater applications
- Filter life display
- External on/off control
- Auto fan
- Leak detection
- Weekly schedule
- Fan speed control
- Group control
- Hot start
- Self diagnostics
- Timer (on/off)
- Child lock

**Optional Accessories:**

- Wireless Remote Controller<sup>3</sup> - PQWRHQ0FDB
- Premium Controller - PREMTA000
- MultiSITE CRC1 Controller - PREMTBVC0
- MultiSITE CRC1+ Controller - PREMTBVC1
- Simple Controller - PREMTCC00U
- Wi-Fi Module - PWFMD200
- Simple Dry Contact (1 contact, 24 VAC external power) - PDRYCB100
- Dry Contact for Economizer - PDRYCB400
- Dry Contact for Third Party Thermostat - PDRYCB320<sup>14</sup>
- Aux Heater Kit - PRARH1<sup>14</sup>
- Remote Temperature Button Sensor - ZRTBS01
- High Efficiency Filter Box - ZFBXB801A

**Entering Mixed Air:**

Cooling Max <sup>4</sup> (°F WB)	76
Heating Min (°F DB)	59

**Unit Data:**

Refrigerant Type	R410A
Refrigerant Control	EEV
Sound Pressure <sup>5</sup> dB(A) (H/M/L)	52 / 50 / 50
Filter Type	Washable
MERV	N/A
Filter Quantity	1
Filter Dimensions <sup>6</sup> (in)	16-1/2" x 55" x 1/4"
Net Unit Weight (lbs)	192
Shipping Weight (lbs)	222

**Fan:**

Type	Sirocco
Fan Quantity	2
Motor/Drive	Brushless Digitally Controlled/Direct
Motor Quantity	2
High Mode Airflow Rate H/M/L (CFM)	2,542/2,260/2,260
High Mode External Static Pressure (ESP) (in wg) <sup>7</sup>	0.87
Airflow Range (CFM)	1808 - 3298
Minimum ESP (in wg) <sup>8</sup>	0.47
Maximum ESP (in wg) <sup>8</sup>	0.98

**Notes:**

1. Maximum power input is rated at maximum setting value.
2. Maximum lift is 27 in from bottom of unit. Check valve not included (field supplied).
3. Requires an LG wall controller because ducted units do not have infrared receiver.
4. See Engineering Manual for sensible and latent capacities.
5. Sound Pressure levels are tested in an anechoic chamber under ISO Standard 3745.
6. Actual filter sizes may vary.
7. At factory fan speed setting.
8. Maximum static pressure may result in reduced airflow (CFM).
9. All Communication cable between Main outdoor units to indoor units / heat recovery units to be 18 AWG, 2-conductor, twisted, stranded, shielded. Ensure the communication cable shield is properly grounded to the Main outdoor unit chassis only. Do not ground the outdoor unit to indoor units / heat recovery units communication cable at any other point. Wiring must comply with all applicable local and national codes.
10. Power wiring cable size must comply with the applicable local and national code.
11. This unit comes with a dry nitrogen charge.
12. All capacities are net with a combination ratio between 95 – 105%.
13. Must follow installation instructions in the applicable LG installation manual.
14. If a Third-Party Dry Contact and an LG internal heater or an LG Auxiliary Heater Kit is installed, supplemental heat capability cannot be controlled by the Third-Party Thermostat.



For continual product development, LG reserves the right to change specifications without notice.

**ARNU963B8A4**  
**Multi V™ High Static Ducted**  
**95,900 Btu/h Indoor Unit**



**Tag #:** \_\_\_\_\_  
**Date:** 7/24/2023  
**PO No.:** \_\_\_\_\_

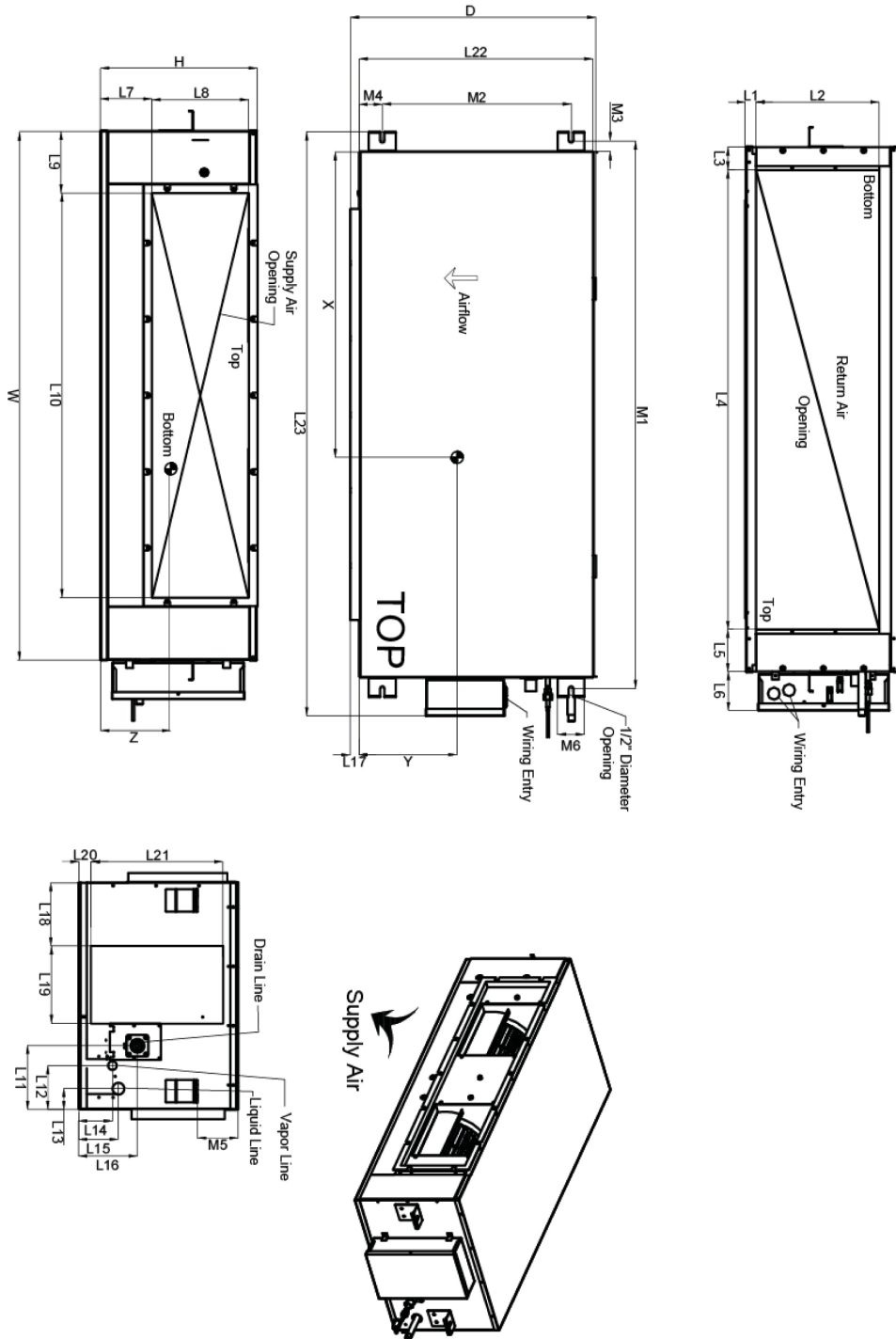

W	61 1/2"
D	28 5/8"
H	18 1/8"
L1	2 3/8"
L2	15 7/16"
L3	2"
L4	5 5/8"
L5	4 9/16"
L6	4 1/2"
L7	6"
L8	11 5/8"
L9	6 3/4"
L10	4 1/4"
L11	7 5/8"
L12	5 1/4"
L13	2 1/2"
L14	4 3/4"
L15	5 1/2"
L16	6 7/8"
L17	1 3/16"
L18	7 13/16"
L19	9 3/16"
L20	1 5/16"
L21	1 5/8"
L22	2 7/8"
L23	6 8 1/4"
M1	63 13/16"
M2	22"
M3	1 3/16"
M4	2 1/2"
M5	4 1/8"
M6	3 3/16"

**Center of Gravity**

X	31 1/16"
Y	18 1/8"
Z	8 3/4"

Note - All dimensions have a tolerance of ± 0.25 in.  
 = Center of gravity

Date: 7/24/2023

For:  File  Resubmit  
 Approval  Other

PO No.:

Architect: Lewis Architects and Engineers

GC: TBD

Engr: Lewis Architects and Engineers

Mech: Comfort Systems USA

Rep: Airetech Corporation

Nick Moore

(Company)

(Project Manager)

## PREMTBVC2 MultiSITE CRC2 Remote Controller



### Electrical:

Power Supply	12VDC power from indoor unit
--------------	------------------------------

### Surrounding Conditions:

Temperature	
Operating	32-122 °F
Storage	-22-122 °F
Humidity	
Operating	5-95% RH (non-condensing)
Storage	0-95% RH (non-condensing)

### Features:

- Customizable color digital touch screen interface with Multilanguage support
- BACnet® Wireless IP (optional)
- ZigBee® Pro Wireless network (optional)
- Role based configuration (password protected)
- Lua scripting
- Function code settings
- Function Code Search Tool
- Date and Time Display
- Room temperature display (-9 °F ~ +9 °F adjustable)
- Humidity Display (-15% ~ +15% adjustable)
- Operation - On/Off
- Mode - Auto/Cool/Dry/Heat/Fan Only
- Occupied cooling and heating temperature setpoints
- Unoccupied cooling and heating temperature setpoints
- 7 day scheduling with mode
- Fan speed - Auto/Low/Med/High/Power
- Discharge vanes - Auto/Swing/Fixed
- Static pressure installer setting

### Optional Accessories (sold separately):

- PZCWRG3 - Group Control Cable Kit
- PZCWRC1 - Extension Cable (for IDUs without terminal blocks)
- ZVRCZPWC2 - ZigBee® Pro Wireless Module<sup>3</sup>
- ZVRCZDWC1 - Wireless Door Window Contact<sup>3</sup>
- ZVRCZMTH1 - Wireless Ceiling Mounted Occupancy, Temperature and Humidity Sensor<sup>3</sup>
- ZVRCZWOC1 - Wireless Wall Mounted Occupancy Sensor<sup>3</sup>
- SEDCO2G5045 - Wireless CO2, Temperature & Humidity Sensor<sup>3</sup>
- ZVRCZTRH1 - Wireless Temperature & Humidity Sensor<sup>3</sup>
- ZVRCZWLS1 - Wireless Water Leak Sensor<sup>3</sup>
- VCM8002V504 - Wi-Fi Module (BACnet Wireless IP)

### Notes:

1. Available functions/features may differ based on connected system.
2. Communication cable can be extended to a maximum of 164 feet.
3. Up to 20 ZigBee® sensors can be connected to the MultiSITE CRC2 Remote Controller.
4. Must follow installation instructions in the applicable LG installation manual.

### Connectivity:

LG Communications	1 Channel/RS-485 V-Net
BACnet® wireless IP (optional)	
ZigBee® Pro wireless mesh network (P) (optional)	

### Communications Cabling Specifications (V-Net):

Type	3 conductor, stranded, twisted, unshielded
Size	AWG 22-3
Length <sup>2</sup>	up to 164 ft

AWG - American Wire Gauge

### Unit Data:

Dimensions	4.72" H x 3.39" W x 1.06" D
Maximum Number of Indoor Units (per controller)	16

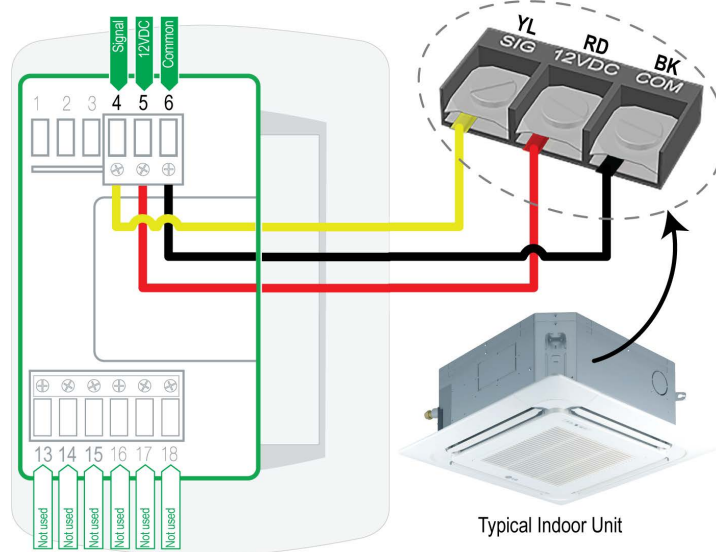

TERMINAL	DESCRIPTION
4 (S)	Tx - Rx Communication
5 (12V)	12 Volts DC
6 (G)	Common

Note: Terminals 1, 2, 3, 13, 14, 15, 16, 17, and 18 are unused.

**PREMTBVC2**  
MultiSITE CRC2 Remote Controller



Tag #:

Date: 7/24/2023

PO No.:

Dimensions: 4.72"H x 3.39"W x 1.06"D

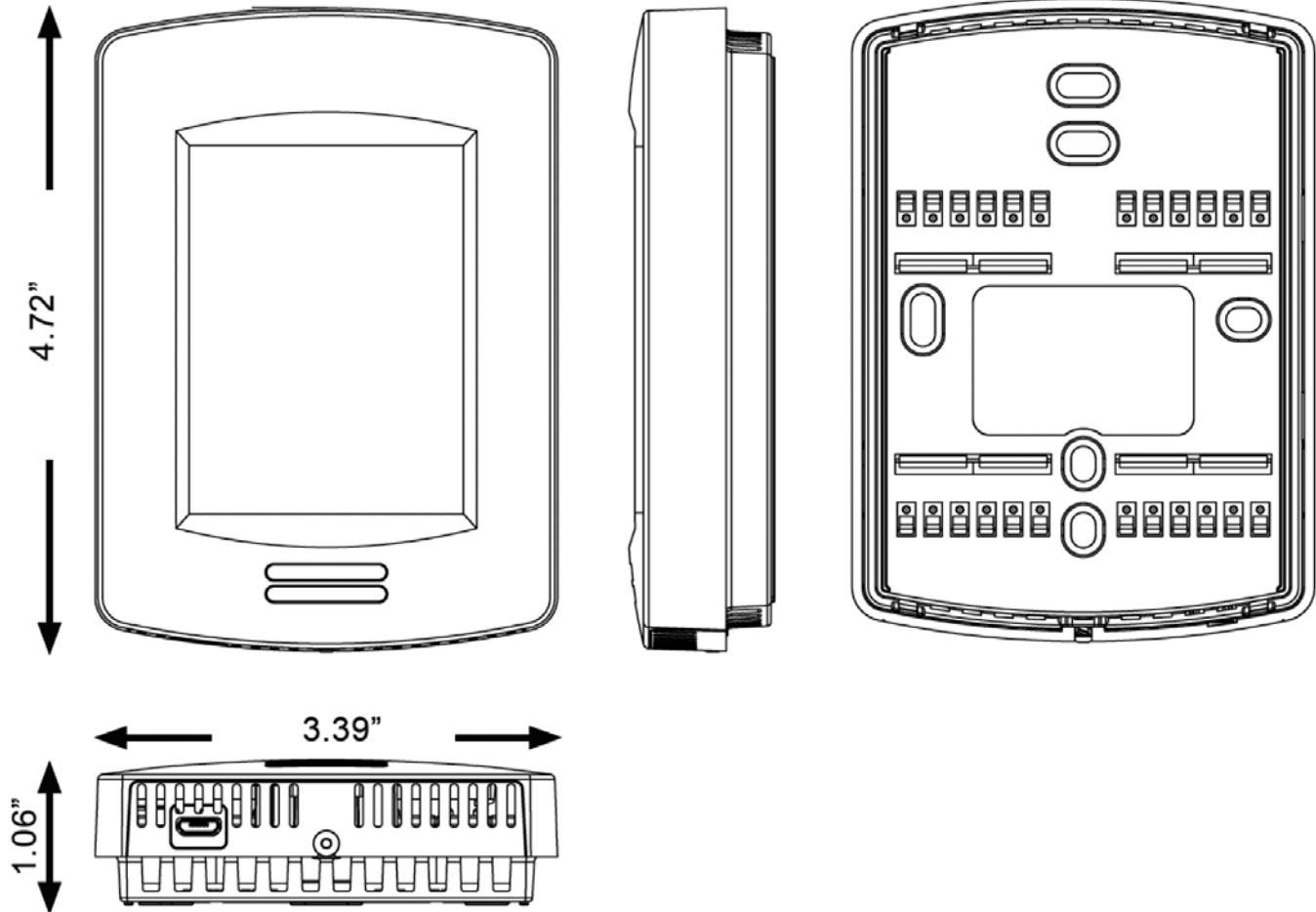

# PREMTBVC2 MultiSITE CRC2 Remote Controller



Tag #: \_\_\_\_\_

Date: 7/24/2023

PO No.: \_\_\_\_\_

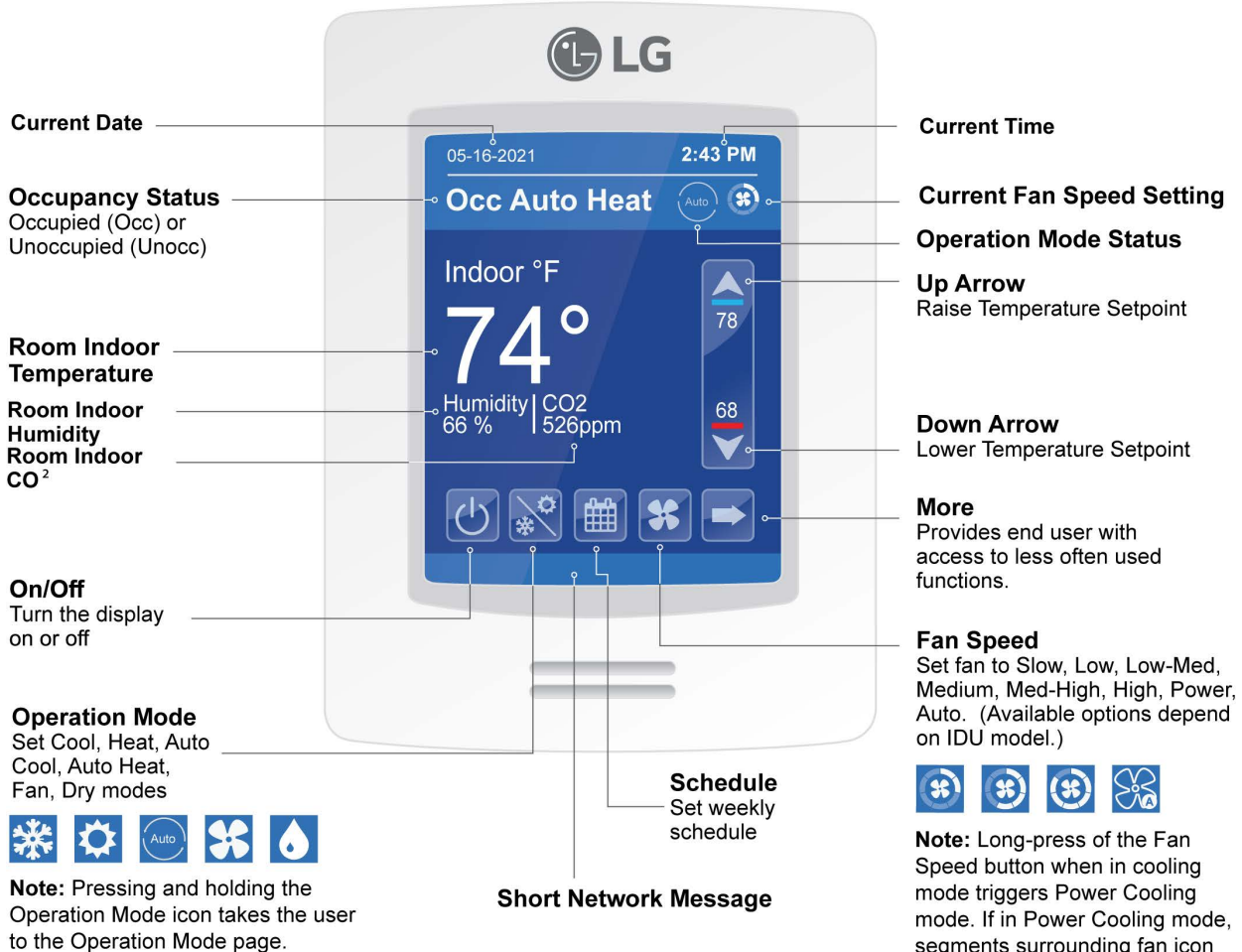

**PREMTBVC2**  
MultiSITE CRC2 Remote Controller



Tag #: \_\_\_\_\_

Date: 7/24/2023

PO No.: \_\_\_\_\_

MultiSITE Remote Controller BACnet® MONITOR Points			
√	BACnet Object Name	Object Type	Description
	ZB_Zone1Temperature_M	AI	Zigbee Zone1 Temperature
	ZB_Zone2Temperature_M	AI	Zigbee Zone2 Temperature
	ZB_Zone3Temperature_M	AI	Zigbee Zone3 Temperature
	ZB_Zone4Temperature_M	AI	Zigbee Zone4 Temperature
	ZB_Zone5Temperature_M	AI	Zigbee Zone5 Temperature
	ZB_Zone6Temperature_M	AI	Zigbee Zone6 Temperature
	ZB_Zone7Temperature_M	AI	Zigbee Zone7 Temperature
	ZB_Zone8Temperature_M	AI	Zigbee Zone8 Temperature
	ZB_Zone9Temperature_M	AI	Zigbee Zone9 Temperature
	ZB_Zone10Temperature_M	AI	Zigbee Zone10 Temperature
	Wi-Fi Network Signal Strength	AI	Wi-Fi Module Signal Strength
	Wi-Fi Module Boot Count	AI	Incremental Boot Count Of Wi-Fi Module
	ZB_Zone11Temperature_M	AI	Zigbee Zone11 Temperature
	ZB_Zone12Temperature_M	AI	Zigbee Zone12 Temperature
	ZB_Zone13Temperature_M	AI	Zigbee Zone13 Temperature
	ZB_Zone14Temperature_M	AI	Zigbee Zone14 Temperature
	ZB_Zone15Temperature_M	AI	Zigbee Zone15 Temperature
	ZB_Zone16Temperature_M	AI	Zigbee Zone16 Temperature
	ZB_Zone17Temperature_M	AI	Zigbee Zone17 Temperature
	ZB_Zone18Temperature_M	AI	Zigbee Zone18 Temperature
	ZB_Zone19Temperature_M	AI	Zigbee Zone19 Temperature
	ZB_Zone20Temperature_M	AI	Zigbee Zone20 Temperature
	ZB_Zone1Humidity_M	AI	Zigbee Zone1 Humidity (%)
	ZB_Zone2Humidity_M	AI	Zigbee Zone2 Humidity (%)
	ZB_Zone3Humidity_M	AI	Zigbee Zone3 Humidity (%)
	ZB_Zone4Humidity_M	AI	Zigbee Zone4 Humidity (%)
	ZB_Zone5Humidity_M	AI	Zigbee Zone5 Humidity (%)
	ZB_Zone6Humidity_M	AI	Zigbee Zone6 Humidity (%)
	ZB_Zone7Humidity_M	AI	Zigbee Zone7 Humidity (%)
	ZB_Zone8Humidity_M	AI	Zigbee Zone8 Humidity (%)
	ZB_Zone9Humidity_M	AI	Zigbee Zone9 Humidity (%)
	ZB_Zone10Humidity_M	AI	Zigbee Zone10 Humidity (%)
	ZB_Zone11Humidity_M	AI	Zigbee Zone11 Humidity (%)
	ZB_Zone12Humidity_M	AI	Zigbee Zone12 Humidity (%)
	ZB_Zone13Humidity_M	AI	Zigbee Zone13 Humidity (%)

**Notes:**

Available functions/features may differ based on the connected system.

For continual product development, LG reserves the right to change specifications without notice.

© LG Electronics U.S.A., Inc., Englewood Cliffs, NJ. All rights reserved. "LG Life's Good" is a registered trademark of LG Corp. /www.lghvac.com

**PREMTBVC2**  
MultiSITE CRC2 Remote Controller



Tag #:

Date: 7/24/2023

PO No.:

MultiSITE Remote Controller BACnet® MONITOR Points			
v	BACnet Object Name	Object Type	Description
	ZB_Zone14Humidity_M	AI	Zigbee Zone14 Humidity (%)
	ZB_Zone15Humidity_M	AI	Zigbee Zone15 Humidity (%)
	ZB_Zone16Humidity_M	AI	Zigbee Zone16 Humidity (%)
	ZB_Zone17Humidity_M	AI	Zigbee Zone17 Humidity (%)
	ZB_Zone18Humidity_M	AI	Zigbee Zone18 Humidity (%)
	ZB_Zone19Humidity_M	AI	Zigbee Zone19 Humidity (%)
	ZB_Zone20Humidity_M	AI	Zigbee Zone20 Humidity (%)
	ZB_Zone1CO2_M	AI	Zigbee Zone1 CO2 (PPM)
	ZB_Zone2CO2_M	AI	Zigbee Zone2 CO2 (PPM)
	ZB_Zone3CO2_M	AI	Zigbee Zone3 CO2 (PPM)
	ZB_Zone4CO2_M	AI	Zigbee Zone4 CO2 (PPM)
	ZB_Zone5CO2_M	AI	Zigbee Zone5 CO2 (PPM)
	ZB_Zone6CO2_M	AI	Zigbee Zone6 CO2 (PPM)
	ZB_Zone7CO2_M	AI	Zigbee Zone7 CO2 (PPM)
	ZB_Zone8CO2_M	AI	Zigbee Zone8 CO2 (PPM)
	ZB_Zone9CO2_M	AI	Zigbee Zone9 CO2 (PPM)
	ZB_Zone10CO2_M	AI	Zigbee Zone10 CO2 (PPM)
	ZB_Zone11CO2_M	AI	Zigbee Zone11 CO2 (PPM)
	ZB_Zone12CO2_M	AI	Zigbee Zone12 CO2 (PPM)
	ZB_Zone13CO2_M	AI	Zigbee Zone13 CO2 (PPM)
	ZB_Zone14CO2_M	AI	Zigbee Zone14 CO2 (PPM)
	ZB_Zone15CO2_M	AI	Zigbee Zone15 CO2 (PPM)
	ZB_Zone16CO2_M	AI	Zigbee Zone16 CO2 (PPM)
	ZB_Zone17CO2_M	AI	Zigbee Zone17 CO2 (PPM)
	ZB_Zone18CO2_M	AI	Zigbee Zone18 CO2 (PPM)
	ZB_Zone19CO2_M	AI	Zigbee Zone19 CO2 (PPM)
	ZB_Zone20CO2_M	AI	Zigbee Zone20 CO2 (PPM)
	FilterRemainTime_M	AI	Filter Time Remaining (Hours)
	CurrentErrorCode_M	AI	Current Error Code
	PipeInTemp_M	AI	Pipe In Temperature
	PipeOutTemp_M	AI	Pipe Out Temperature
	MiddlePipeTemp_M	AI	Middle Pipe Temperature
	ODUgivenAddrs_M	AI	Assigned Address By Outdoor Unit
	Effective Cool Setpoint	AI	Effective Dual Setpoint Cooling Setpoint When ADR Is Active

**Notes:**

Available functions/features may differ based on the connected system.

For continual product development, LG reserves the right to change specifications without notice.

© LG Electronics U.S.A., Inc., Englewood Cliffs, NJ. All rights reserved. "LG Life's Good" is a registered trademark of LG Corp. /www.lghvac.com

**PREMTBVC2**  
MultiSITE CRC2 Remote Controller



**Tag #:** \_\_\_\_\_  
Date: 7/24/2023  
PO No.: \_\_\_\_\_

MultiSITE Remote Controller BACnet® MONITOR Points			
v	BACnet Object Name	Object Type	Description
	Effective Heat Setpoint	AI	Effective Dual Setpoint Heating Setpoint When ADR Is Active
	Effective Single Setpoint	AI	Effective Single Setpoint Setpoint When ADR Is Active
	Effective Single Deadband	AI	Effective Single Setpoint Deadband When ADR Is Active
	PreviousErrorCode_M	AV	2nd Chronological Error Code
	ErrorCode3_M	AV	3rd Chronological Error Code
	ErrorCode4_M	AV	4th Chronological Error Code
	ErrorCode5_M	AV	5th Chronological Error Code
	ErrorCode6_M	AV	6th Chronological Error Code
	ErrorCode7_M	AV	7th Chronological Error Code
	ErrorCode8_M	AV	8th Chronological Error Code
	ErrorCode9_M	AV	9th Chronological Error Code
	ErrorCode10_M	AV	10th Chronological Error Code
	OldestErrorCode_M	AV	11th Chronological Error Code
	ZB_LowBattAlarm	BV	Global Zigbee Battery Sensor Alarm
	ADR Active	BV	Effective ADR Status
	FilterAlarm_M	BV	Filter Alarm Status
	MsgAddressLock_M	BV	Central Control Address Lock Status
	MsgOverrideActive	BV	Override Status
	ZB_Snsr_Wn_Interlock_M	BV	Zigbee Window Contact Interlock Status
	Wi-Fi Device Name	CSV	Wi-Fi Device Name
	Wi-Fi Firmware Version	CSV	Wi-Fi Module Firmware Version
	MAC Address	CSV	Wi-Fi Module MAC Address
	Wi-Fi Network SSID	CSV	Wi-Fi Network SSID
	Wi-Fi Network IP Address	CSV	Wi-Fi Network IP Address
	Zigbee Firmware Revision	CSV	Zigbee Firmware Version
	Zigbee IEEE Address	CSV	Zigbee MAC Address
	ZB_Zone1Address_M	CSV	Zigbee Zone1 Address
	ZB_Zone2Address_M	CSV	Zigbee Zone2 Address
	ZB_Zone3Address_M	CSV	Zigbee Zone3 Address
	ZB_Zone4Address_M	CSV	Zigbee Zone4 Address
	ZB_Zone5Address_M	CSV	Zigbee Zone5 Address
	ZB_Zone6Address_M	CSV	Zigbee Zone6 Address

**Notes:**

Available functions/features may differ based on the connected system.

For continual product development, LG reserves the right to change specifications without notice.

© LG Electronics U.S.A., Inc., Englewood Cliffs, NJ. All rights reserved. "LG Life's Good" is a registered trademark of LG Corp. /www.lghvac.com

**PREMTBVC2**  
MultiSITE CRC2 Remote Controller



Tag #: \_\_\_\_\_  
Date: 7/24/2023  
PO No.: \_\_\_\_\_

MultiSITE Remote Controller BACnet® MONITOR Points			
v	BACnet Object Name	Object Type	Description
	ZB_Zone7Address_M	CSV	Zigbee Zone7 Address
	ZB_Zone8Address_M	CSV	Zigbee Zone8 Address
	ZB_Zone9Address_M	CSV	Zigbee Zone9 Address
	ZB_Zone10Address_M	CSV	Zigbee Zone10 Address
	ZB_Zone11Address_M	CSV	Zigbee Zone11 Address
	ZB_Zone12Address_M	CSV	Zigbee Zone12 Address
	ZB_Zone13Address_M	CSV	Zigbee Zone13 Address
	ZB_Zone14Address_M	CSV	Zigbee Zone14 Address
	ZB_Zone15Address_M	CSV	Zigbee Zone15 Address
	ZB_Zone16Address_M	CSV	Zigbee Zone16 Address
	ZB_Zone17Address_M	CSV	Zigbee Zone17 Address
	ZB_Zone18Address_M	CSV	Zigbee Zone18 Address
	ZB_Zone19Address_M	CSV	Zigbee Zone19 Address
	ZB_Zone20Address_M	CSV	Zigbee Zone20 Address
	ZB_Zone1Status_M	MSI	Zigbee Zone1 Status
	ZB_Zone1BattStatus_M	MSI	Zigbee Zone1 Battery Status
	ZB_Zone1PairingStatus_M	MSI	Zigbee Zone1 Pairing Status
	ZB_Zone2Status_M	MSI	Zigbee Zone2 Status
	ZB_Zone2BattStatus_M	MSI	Zigbee Zone2 Battery Status
	ZB_Zone2PairingStatus_M	MSI	Zigbee Zone2 Pairing Status
	ZB_Zone3Status_M	MSI	Zigbee Zone3 Status
	ZB_Zone3BattStatus_M	MSI	Zigbee Zone3 Battery Status
	ZB_Zone3PairingStatus_M	MSI	Zigbee Zone3 Pairing Status
	ZB_Zone4Status_M	MSI	Zigbee Zone4 Status
	ZB_Zone4BattStatus_M	MSI	Zigbee Zone4 Battery Status
	ZB_Zone4PairingStatus_M	MSI	Zigbee Zone4 Pairing Status
	ZB_Zone5Status_M	MSI	Zigbee Zone5 Status
	ZB_Zone5BattStatus_M	MSI	Zigbee Zone5 Battery Status
	ZB_Zone5PairingStatus_M	MSI	Zigbee Zone5 Pairing Status
	ZB_Zone6Status_M	MSI	Zigbee Zone6 Status
	ZB_Zone6BattStatus_M	MSI	Zigbee Zone6 Battery Status
	ZB_Zone6PairingStatus_M	MSI	Zigbee Zone6 Pairing Status
	ZB_Zone7Status_M	MSI	Zigbee Zone7 Status
	ZB_Zone7BattStatus_M	MSI	Zigbee Zone7 Battery Status

**Notes:**

Available functions/features may differ based on the connected system.

For continual product development, LG reserves the right to change specifications without notice.

© LG Electronics U.S.A., Inc., Englewood Cliffs, NJ. All rights reserved. "LG Life's Good" is a registered trademark of LG Corp. /www.lghvac.com

**PREMTBVC2**  
MultiSITE CRC2 Remote Controller



Tag #: \_\_\_\_\_

Date: 7/24/2023

PO No.: \_\_\_\_\_

MultiSITE Remote Controller BACnet® MONITOR Points			
v	BACnet Object Name	Object Type	Description
	ZB_Zone7PairingStatus_M	MSI	Zigbee Zone7 Pairing Status
	ZB_Zone8Status_M	MSI	Zigbee Zone8 Status
	ZB_Zone8BattStatus_M	MSI	Zigbee Zone8 Battery Status
	ZB_Zone8PairingStatus_M	MSI	Zigbee Zone8 Pairing Status
	ZB_Zone9Status_M	MSI	Zigbee Zone9 Status
	ZB_Zone9BattStatus_M	MSI	Zigbee Zone9 Battery Status
	ZB_Zone9PairingStatus_M	MSI	Zigbee Zone9 Pairing Status
	ZB_Zone10Status_M	MSI	Zigbee Zone10 Status
	ZB_Zone10BattStatus_M	MSI	Zigbee Zone10 Battery Status
	ZB_Zone10PairingStatus_M	MSI	Zigbee Zone10 Pairing Status
	ZB_Zone11Status_M	MSI	Zigbee Zone11 Status
	ZB_Zone11BattStatus_M	MSI	Zigbee Zone11 Battery Status
	ZB_Zone11PairingStatus_M	MSI	Zigbee Zone11 Pairing Status
	Wi-Fi Module Status	MSI	Wi-Fi Module Status
	Wi-Fi Status	MSI	Wi-Fi Network Status
	BACnet IP Status	MSI	BACnet IP Network Status
	SMTP Server Status	MSI	Status Of SMTP Server Used For Email Notifications
	ZB_Zone12Status_M	MSI	Zigbee Zone12 Status
	ZB_Zone12BattStatus_M	MSI	Zigbee Zone12 Battery Status
	ZB_Zone12PairingStatus_M	MSI	Zigbee Zone12 Pairing Status
	ZB_Zone13Status_M	MSI	Zigbee Zone13 Status
	ZB_Zone13BattStatus_M	MSI	Zigbee Zone13 Battery Status
	ZB_Zone13PairingStatus_M	MSI	Zigbee Zone13 Pairing Status
	ZB_Zone14Status_M	MSI	Zigbee Zone14 Status
	ZB_Zone14BattStatus_M	MSI	Zigbee Zone14 Battery Status
	ZB_Zone14PairingStatus_M	MSI	Zigbee Zone14 Pairing Status
	ZB_Zone15Status_M	MSI	Zigbee Zone15 Status
	ZB_Zone15BattStatus_M	MSI	Zigbee Zone15 Battery Status
	ZB_Zone15PairingStatus_M	MSI	Zigbee Zone15 Pairing Status
	ZB_Zone16Status_M	MSI	Zigbee Zone16 Status
	ZB_Zone16BattStatus_M	MSI	Zigbee Zone16 Battery Status
	ZB_Zone16PairingStatus_M	MSI	Zigbee Zone16 Pairing Status
	ZB_Zone17Status_M	MSI	Zigbee Zone17 Status

**Notes:**

Available functions/features may differ based on the connected system.

For continual product development, LG reserves the right to change specifications without notice.

© LG Electronics U.S.A., Inc., Englewood Cliffs, NJ. All rights reserved. "LG Life's Good" is a registered trademark of LG Corp. /www.lghvac.com

**PREMTBVC2**  
MultiSITE CRC2 Remote Controller



Tag #:

Date: 7/24/2023

PO No.:

MultiSITE Remote Controller BACnet® MONITOR Points			
v	BACnet Object Name	Object Type	Description
	ZB_Zone17BattStatus_M	MSI	Zigbee Zone17 Battery Status
	ZB_Zone17PairingStatus_M	MSI	Zigbee Zone17 Pairing Status
	ZB_Zone18Status_M	MSI	Zigbee Zone18 Status
	ZB_Zone18BattStatus_M	MSI	Zigbee Zone18 Battery Status
	ZB_Zone18PairingStatus_M	MSI	Zigbee Zone18 Pairing Status
	ZB_Zone19Status_M	MSI	Zigbee Zone19 Status
	ZB_Zone19BattStatus_M	MSI	Zigbee Zone19 Battery Status
	ZB_Zone19PairingStatus_M	MSI	Zigbee Zone19 Pairing Status
	ZB_Zone20Status_M	MSI	Zigbee Zone20 Status
	ZB_Zone20BattStatus_M	MSI	Zigbee Zone20 Battery Status
	ZB_Zone20PairingStatus_M	MSI	Zigbee Zone20 Pairing Status
	PipeTempCnfg_M	MSI	Pipe Temperature Configuration Status (Supported or Unsupported)
	ODUsilentMode_M	MSI	ODU Silent Mode Status
	SmartLoadCtrl_M	MSI	Smart Load Control Status
	OccStatus_M	MSI	Occupancy Status
	ODUstatus_M	MSI	Outdoor Unit Status
	ODUType_M	MSI	Outdoor Unit Type
	IDUType_M	MSI	Indoor Unit Type
	AirQuality_M	MSI	Air Quality Status

**Notes:**

Available functions/features may differ based on the connected system.

For continual product development, LG reserves the right to change specifications without notice.

© LG Electronics U.S.A., Inc., Englewood Cliffs, NJ. All rights reserved. "LG Life's Good" is a registered trademark of LG Corp. /www.lghvac.com

**PREMTBVC2**  
MultiSITE CRC2 Remote Controller



Tag #:

Date: 7/24/2023

PO No.:

<b>MultiSITE Remote Controller BACnet® CONTROL Points</b>			
<b>v</b>	<b>BACnet Object Name</b>	<b>Object Type</b>	<b>Description</b>
	DisplayLowBacklight	AV	Display Brightness Setting For Low Backlight Conditions
	RoomTempCalibration	AV	Room Temperature Sensor Calibration Offset
	Calibrate Humidity Sensor	AV	Humidity Sensor Calibration Offset
	BACnetComAddr	AV	BACnet Communications Address
	BACnetStackPollRate	AV	BACnet Stack Poll Rate
	LuaParameterA (AV25)	AV	Lua ParamaterA
	LuaParameterB (AV26)	AV	Lua ParamaterB
	LuaParameterC (AV27)	AV	Lua ParameterC
	LuaParameterD (AV28)	AV	Lua ParameterD
	LuaParameterE (AV29)	AV	Lua ParameterE
	LuaParameterF (AV30)	AV	Lua ParameterF
	HeatingSP	AV	Heating SP Setting (Dual SP)
	CoolingSP	AV	Cooling SP Setting (Dual SP)
	ConfigPassword	AV	Configuration Password (Password protects Installer Settings)
	UserPassword	AV	User Password (Password protects all settings)
	DualSPdeadband	AV	Minimum Deadband Setting (Dual SP)
	RoomTemp	AV	Room Temperature
	RoomHumidity	AV	Room Humidity
	ADR Offset	AV	ADR Setpoint Offset Value
	LuaParameterG (AV225)	AV	Lua ParameterG
	LuaParameterH (AV226)	AV	Lua ParameterH
	LuaParameterI (AV227)	AV	Lua ParameterI
	LuaParameterJ (AV228)	AV	Lua ParameterJ
	LuaParameterK (AV229)	AV	Lua ParameterK
	LuaParameterL (AV230)	AV	Lua ParameterL
	SingleSP	AV	Setpoint Setting (Single SP)
	SingleSetpointMax	AV	Single Setpoint Maximum Setting
	SingleSetpointMin	AV	Single Setpoint Minimum Setting
	CoolingSPMax	AV	Dual Setpoint Cooling Maximum Setting
	CoolingSPMin	AV	Dual Setpoint Cooling Minimum Setting
	HeatingSPMax	AV	Dual Setpoint Heating Maximum Setting
	HeatingSPMin	AV	Dual Setpoint Heating Minimum Setting

**Notes:**

Available functions/features may differ based on the connected system.

For continual product development, LG reserves the right to change specifications without notice.

© LG Electronics U.S.A., Inc., Englewood Cliffs, NJ. All rights reserved. "LG Life's Good" is a registered trademark of LG Corp. /www.lghvac.com

**PREMTBVC2**  
MultiSITE CRC2 Remote Controller



Tag #: \_\_\_\_\_  
Date: 7/24/2023  
PO No.: \_\_\_\_\_

MultiSITE Remote Controller BACnet® CONTROL Points			
v	BACnet Object Name	Object Type	Description
	OverrideCoolingSP	AV	Cooling Override Setpoint Setting
	OverrideHeatingSP	AV	Heating Override Setpoint Setting
	SetbackCoolingSP	AV	Cooling Setback Setpoint Setting
	SetbackHeatingSP	AV	Heating Setback Setpoint Setting
	SingleSPdeadband	AV	Single Setpoint Deadband
	ForceHighBacklight	BV	Force Backlight
	DisplayLongScreenMsg	BV	Show Text Of MsgLongScreenMsgTxt On Main Screen
	PIR Local Motion	BV	Logical OR'd Instantaneous Status of All Motion Sensors
	Utility Signal	BV	ADR Request Signal From Utility
	FilterAlarmRelease	BV	Filter Alarm Reset
	MsgSetbackActive	BV	Setback Status
	TestModeOccupancy	BV	Reserved/Do Not Use
	MsgShortScreenMsgTxt	CSV	Location Message (Displays message at bottom of screen)
	MsgLongScreenMsgTxt	CSV	Description Message (Displays message on main screen)
	ZB_NetworkStatus_M	MSI	Zigbee Network Status
	ZB_Zone1SensorType_M	MSI	Zigbee Zone1 Sensor Type
	ZB_Zone2SensorType_M	MSI	Zigbee Zone2 Sensor Type
	ZB_Zone3SensorType_M	MSI	Zigbee Zone3 Sensor Type
	ZB_Zone4SensorType_M	MSI	Zigbee Zone4 Sensor Type
	ZB_Zone5SensorType_M	MSI	Zigbee Zone5 Sensor Type
	ZB_Zone6SensorType_M	MSI	Zigbee Zone6 Sensor Type
	ZB_Zone7SensorType_M	MSI	Zigbee Zone7 Sensor Type
	ZB_Zone8SensorType_M	MSI	Zigbee Zone8 Sensor Type
	ZB_Zone9SensorType_M	MSI	Zigbee Zone8 Sensor Type
	ZB_Zone10SensorType_M	MSI	Zigbee Zone10 Sensor Type
	ZB_Zone11SensorType_M	MSI	Zigbee Zone11 Sensor Type
	ZB_Zone12SensorType_M	MSI	Zigbee Zone12 Sensor Type
	ZB_Zone13SensorType_M	MSI	Zigbee Zone13 Sensor Type
	ZB_Zone14SensorType_M	MSI	Zigbee Zone14 Sensor Type
	ZB_Zone15SensorType_M	MSI	Zigbee Zone15 Sensor Type
	ZB_Zone16SensorType_M	MSI	Zigbee Zone16 Sensor Type

**Notes:**

Available functions/features may differ based on the connected system.

For continual product development, LG reserves the right to change specifications without notice.

© LG Electronics U.S.A., Inc., Englewood Cliffs, NJ. All rights reserved. "LG Life's Good" is a registered trademark of LG Corp. /www.lghvac.com

**PREMTBVC2**  
MultiSITE CRC2 Remote Controller



Tag #: \_\_\_\_\_

Date: 7/24/2023

PO No.: \_\_\_\_\_

<b>MultiSITE Remote Controller BACnet® CONTROL Points</b>			
<b>v</b>	<b>BACnet Object Name</b>	<b>Object Type</b>	<b>Description</b>
	ZB_Zone17SensorType_M	MSI	Zigbee Zone17 Sensor Type
	ZB_Zone18SensorType_M	MSI	Zigbee Zone18 Sensor Type
	ZB_Zone19SensorType_M	MSI	Zigbee Zone19 Sensor Type
	ZB_Zone20SensorType_M	MSI	Zigbee Zone20 Sensor Type
	DisplayColor	MV	Display Background Color Setting
	DisplayLanguage	MV	Display Language Setting
	DisplayTimeFormat	MV	Time Format Setting
	BACnetNetworkUnits	MV	BACnet Network Units Setting
		MV	System Mode Setting
	FanSpeed	MV	Fan Speed Setting
	DisplayUseStandbyScreen	MV	Standby Screen Setting
	TempUnits	MV	Temperature Units Setting (°F or °C)
	Relative humidity sensor	MV	Humidity Sensor Input Selection
	CO2 source	MV	CO2 Sensor Input Selection
	ADR Enable	MV	ADR Enable/Disable
	ZB_Zone1SnsrType	MV	Zigbee Zone1 Sensor Type
	ZB_Zone2SnsrType	MV	Zigbee Zone2 Sensor Type
	ZB_Zone3SnsrType	MV	Zigbee Zone3 Sensor Type
	ZB_Zone4SnsrType	MV	Zigbee Zone4 Sensor Type
	ZB_Zone5SnsrType	MV	Zigbee Zone5 Sensor Type
	ZB_Zone6SnsrType	MV	Zigbee Zone6 Sensor Type
	ZB_Zone7SnsrType	MV	Zigbee Zone7 Sensor Type
	ZB_Zone8SnsrType	MV	Zigbee Zone8 Sensor Type
	ZB_Zone9SnsrType	MV	Zigbee Zone9 Sensor Type
	ZB_Zone10SnsrType	MV	Zigbee Zone10 Sensor Type
	ZB_Zone11SnsrType	MV	Zigbee Zone11 Sensor Type
	ZB_Zone12SnsrType	MV	Zigbee Zone12 Sensor Type
	ZB_Zone13SnsrType	MV	Zigbee Zone13 Sensor Type
	ZB_Zone14SnsrType	MV	Zigbee Zone14 Sensor Type
	ZB_Zone15SnsrType	MV	Zigbee Zone15 Sensor Type
	ZB_Zone16SnsrType	MV	Zigbee Zone16 Sensor Type
	ZB_Zone17SnsrType	MV	Zigbee Zone17 Sensor Type
	ZB_Zone18SnsrType	MV	Zigbee Zone18 Sensor Type
	ZB_Zone19SnsrType	MV	Zigbee Zone19 Sensor Type

**Notes:**

Available functions/features may differ based on the connected system.

For continual product development, LG reserves the right to change specifications without notice.

© LG Electronics U.S.A., Inc., Englewood Cliffs, NJ. All rights reserved. "LG Life's Good" is a registered trademark of LG Corp. /www.lghvac.com

**PREMTBVC2**  
MultiSITE CRC2 Remote Controller



Tag #:

Date: 7/24/2023

PO No.:

<b>MultiSITE Remote Controller BACnet® CONTROL Points</b>			
<b>v</b>	<b>BACnet Object Name</b>	<b>Object Type</b>	<b>Description</b>
	ZB_Zone20SnrType	MV	Zigbee Zone20 Sensor Type
	DisplayShowOnOff	MV	Show or Hide On/Off Setting
	DisplayShowMode	MV	Show or Hide Mode Setting
	DisplayShowSchedule	MV	Show or Hide Schedule Setting
	DisplayShowMore	MV	Show or Hide More Setting
	DisplayShowSetTemp	MV	Show or Hide Set Temperature Setting
	DisplayShowSpaceTemp	MV	Show or Hide Space Temperature Value
	DisplayShowFanSpeed	MV	Show or Hide Fan Speed Setting
	DisplayShowHumidity	MV	Show or Hide Humidity Value
	DisplayShowAirQuality	MV	Show or Hide Air Quality (for unhealthy levels only)
	DisplayShowCO2	MV	Show or Hide CO2 Value
	TempSenseLoc	MV	Temperature Sensing Location Setting
	IDUonOff	MV	Indoor Unit On/Off Setting
	AirflowUpDown	MV	Airflow Up/Down Setting
	AirflowLeftRight	MV	Airflow Left/Right Setting
	AirflowCircular	MV	Airflow Circular Setting
	SingleDualSP	MV	Single or Dual Setpoint Setting
	OverrideMode	MV	Mode Override Setting
	OverrideFanSpeed	MV	Fan Speed Override Setting
	OverrideTimer	MV	Timer Override Setting
	SetbackMode	MV	Mode Setback Setting
	SetbackFanSpeed	MV	Fan Speed Setback Setting
	CntrlrOccSensor	MV	On-board Occupancy Sensor Enable/Disable (Only on models PREMTBVC3/PREMTBVC4)
	ControllerMinOccOnTime	MV	Minimum Occupancy Time Delay
	DisableSchedules	MV	Disable Local Schedules Setting
	ZB_Snsr_Wn_Delay	MV	Zigbee Window Contact Interlock Delay Setting
	ZB_Snsr_Win_Interlock	MV	Zigbee Window Contact Interlock Setting
	AirflowSmart	MV	Airflow Smart Setting
	AirflowRefresh	MV	Airflow Refresh Setting
	FloorTempSensing	MV	Enable Floor Temperature Sensing (Dual Vane 4-Way Cassette Only)
	HumanDetection	MV	Enable Human Detection (Dual Vane 4-Way Cassette Only)

**Notes:**

Available functions/features may differ based on the connected system.

For continual product development, LG reserves the right to change specifications without notice.

© LG Electronics U.S.A., Inc., Englewood Cliffs, NJ. All rights reserved. "LG Life's Good" is a registered trademark of LG Corp. /www.lghvac.com

**PREMTBVC2**  
MultiSITE CRC2 Remote Controller



Tag #: \_\_\_\_\_

Date: 7/24/2023

PO No.: \_\_\_\_\_

<b>MultiSITE Remote Controller BACnet® CONTROL Points</b>			
<b>v</b>	<b>BACnet Object Name</b>	<b>Object Type</b>	<b>Description</b>
	HumanSensingFreq	MV	Human Detection Sensing Frequency Adjustment (Dual Vane 4-Way Cassette Only)
	HumanSensitivity	MV	Human Detection Sensitivity Adjustment (Dual Vane 4-Way Cassette Only)
	DetectionArea	MV	Human Detection Area Adjustment (Dual Vane 4-Way Cassette Only)
	UnoccControl	MV	Human Detection Unoccupied Behavior (Dual Vane 4-Way Cassette Only)
	UnoccStepTime	MV	Human Detection Unoccupied Setpoint Step Timing (Dual Vane 4-Way Cassette Only)
	SetbackEnabled	MV	Enable/Disable Setback
	OverrideEnabled	MV	Enable/Disable Override
	USB Logger	MV	Reserved/Do Not Use
	ADR Override	MV	Override Active ADR Event

**Notes:**

Available functions/features may differ based on the connected system.

For continual product development, LG reserves the right to change specifications without notice.

© LG Electronics U.S.A., Inc., Englewood Cliffs, NJ. All rights reserved. "LG Life's Good" is a registered trademark of LG Corp. /www.lghvac.com

Date: 7/24/2023

For:  File  Resubmit  
 Approval  Other \_\_\_\_\_

PO No.:

Architect: Lewis Architects and Engineers

GC: TBD

Engr: Lewis Architects and Engineers

Mech: Comfort Systems USA

Rep: Airetech Corporation  
 (Company)

Nick Moore  
 (Project Manager)

# PDRYCB320

## Dry Contact for Thermostat

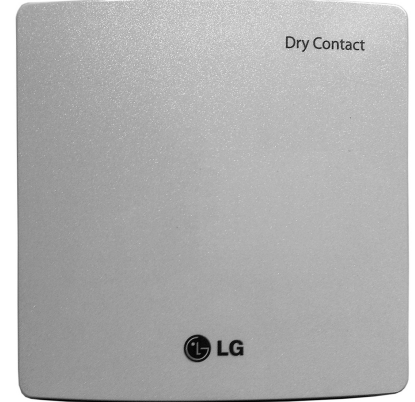

### Electrical:

Power Supply	12 VDC (from indoor unit)
--------------	---------------------------

### Surrounding Conditions:

Operating Temperature	14 to 158°F
Storage Temperature	-4 to 176°F
Humidity	0 to 98% (non-condensing)

### Unit Data:

Dimensions	4-1/8" W x 3-1/16" H x 1-3/8" D
Contact Rating	3A @ 125 VAC

### Connectivity:

LG Communications	30" Wiring Harness (included)
-------------------	-------------------------------

### Standard Features:

- Control indoor unit operation with 3rd party thermostat or controller.
- Inputs for control of Unit On/Off, Thermo On/Off, Mode (Cool/Heat/ Fan) and Fan Speed (Low, Med, High).
- Universal input to set a desired set point using DC Voltage or resistance.
- Setpoint Tracking Logic for improved inverter utilization.
- Outputs for Operation and Error Status.
- Compatible with all Multi V and select DFS units<sup>1</sup>.

### Notes:

1. For a complete list of compatible IDUs, contact your LG representative.
2. Must follow installation instructions in the applicable LG installation manual.

### Wiring:

For setting desired temperature using Universal Input:

- 2.5 - 8.5 VDC (64°F to 86°F)
- 2.8 - 8.5 (kOhm) (64°F to 86°F)

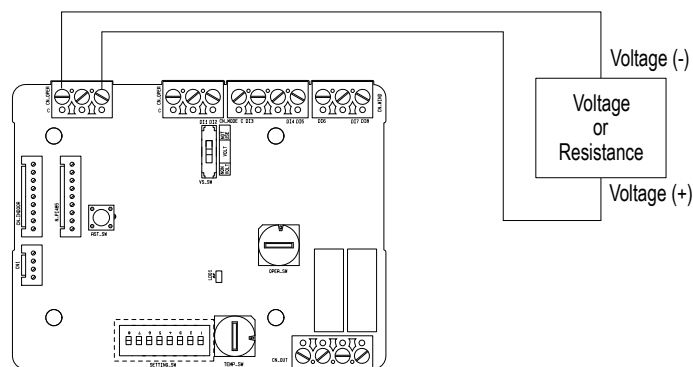

### Parts Description:

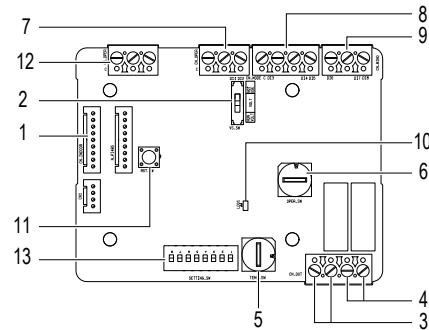

1. CN\_INDOOR: Connector for indoor unit.
2. VS\_SW: Switch to select External Voltage or Non Voltage for input contact signal.
3. CN\_OUT (O1,O2): Output terminal to show whether the indoor unit is operating (Relay contact).
4. CN\_OUT (E3,E4): Output terminal to show whether there is an error with the indoor unit (Relay contact).
5. TEMP\_SW: Switch to set the desired temperature of the indoor unit.
6. OPER\_SW: Switch to select whether to use set function of Dry contact.
7. CN\_OPER: Input terminal for thermo & operation signal.
8. CN\_MODE: Input terminal for Mode signal.
9. CN\_WIND: Input terminal for Wind signal.
10. LD01: LED to display the status of Dry contact Module.
11. RST\_SW: Reset switch.
12. CN\_AI: Input terminal for Universal Input.
13. SETTING\_SW: Switch to select the Universal Input.

### Wiring:

For input contact voltage: DC 5-12 V, 24 V~

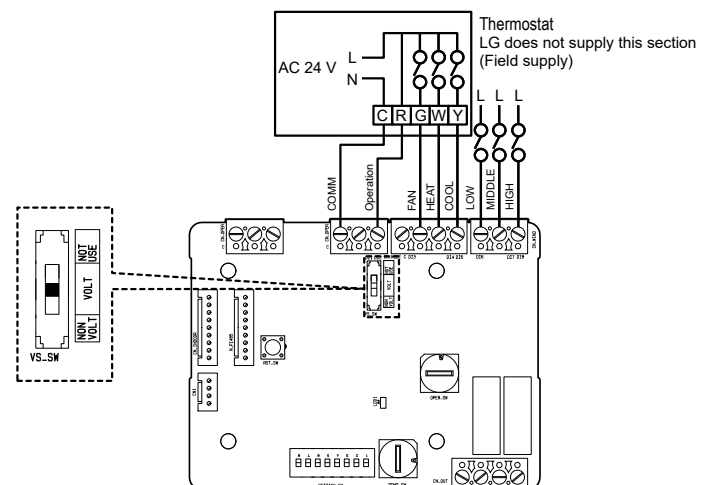

**Date:** 7/24/2023

**For:**  File  Resubmit  
 Approval  Other \_\_\_\_\_

**PO No.:**

**Architect:** Lewis Architects and Engineers

**GC:** TBD

**Engr:** Lewis Architects and Engineers

**Mech:** Comfort Systems USA

**Rep:** Airetech Corporation  
 (Company)

Nick Moore  
 (Project Manager)

**ARUM144DTE5**  
**Multi V™ 5 with LGRED° 460V ODU**  
**12 Ton Single Frame Heat Pump and Heat Recovery**



**Operating Range:**

Cooling (°F DB)**	5 - 122
Heating (°F WB)	-22 - 61
Synchronous	
Cooling Based (°F DB)	14 - 81
Heating Based (°F WB)	14 - 61

**Performance:**

Cooling Mode:

Nominal Capacity (Btu/h)	144,000
Power Input (kW)	9.30

Heating Mode:

Nominal Capacity (Btu/h)	162,000
Power Input (kW)	10.54

Rated capacity is certified under AHRI Standard 1230. Ratings are subject to change without notice. Current certified ratings are available at [www.ahridirectory.org](http://www.ahridirectory.org).

**Electrical:**

Frame	ARUM144DTE5
Power Supply (V/Hz/Ø) <sup>1</sup>	460/60/3
MOP (A)	35
MCA (A)	26.4
Rated Amps (A)	23.8
Compressor A (A)	10.3
Compressor B (B)	8.5
Fan (A)	5.0

**Piping:<sup>2</sup>**

Frame	ARUM144DTE5
Refrigerant Charge (lbs.)	26.5
Liquid (in., O.D.)	1/2 Braze
High Pressure Vapor (Heat Recov only; in., O.D.)	7/8 Braze
Low Pressure Vapor (in., O.D.)	1-1/8 Braze

**Standard Features:**

- Advanced Smart Load Control
- Intelligent Heating
- HiPOR (High Pressure Oil Return)
- Smart Oil Control
- Night Quiet Operation
- Fault Detection and Diagnosis
- Active Refrigerant Control
- Variable Heat Path Exchanger
- Subcooling and Vapor Injection Control
- Liquid Cooled Inverter Controller
- Advanced Comfort Cooling

**Optional Accessories:**

- Air Guide - ZAGDKA52A
- Hail Guard Kit - ZHGDKA52A
- Low Ambient Baffle Kit - ZLABKA52A (2), Control Kit - PRVC2 (1 per system)
- Base Pan Heater - ZPLT2A51A

\*\*Cooling range with the Low Ambient Baffle Kit (sold separately) is -9.9°F to +122°F and is achieved only when all indoor units are operating in cooling mode. Does not impact heat recovery system synchronous operating range.

**Unit Data:**

Refrigerant Type	R410A
Refrigerant Control	EEV
Max. Number of Indoor Units <sup>3</sup>	24
Sound Pressure <sup>4</sup> dB(A)	60.0
Weight	
Frame	ARUM144DTE5
Net (lbs.)	639
Shipping (lbs.)	666
Communication Cable (No x AWG) <sup>5</sup>	2 x 18
Heat Exchanger Coating	Black Coated Fin™

**Compressor:**

Type	HSS DC Scroll
Quantity	2
Oil / Type	PVE / FVC68D

**Fan:**

Type	Propeller
Quantity	2
Motor Drive	Brushless Digitally Controlled Direct
Air Flow Rate (rated/max, CFM)	9,300 / 11,300

**Notes:**

1. Power wiring cable size must comply with the applicable local and national codes. Cables terminate at each frame.
2. For main pipe segment size, refer to the LATS Multi V tree diagram.
3. The combination ratio must be between 50-130%.
4. Sound pressure levels are tested in an anechoic chamber under ISO Standard 3745 for the combination of outdoor units.
5. Communication cable between ODU and IDUs must be 2-conductor, 18 AWG, twisted, stranded, and shielded. Ensure the communication cable shield is properly grounded to the Main ODU chassis only. Do not ground the communication cable at any other point. Wiring must comply with all applicable local and national codes.
6. Acceptable operating voltage: 414 - 528V
7. Fan ESP (in wg) selectable range is 0.16 to 0.32.



# ARUM144DTE5

Multi V™ 5 with LGRED® 460V ODU

12 Ton Single Frame Heat Pump and Heat Recovery



Tag No.: \_\_\_\_\_

Date: 7/24/2023

PO No.: \_\_\_\_\_

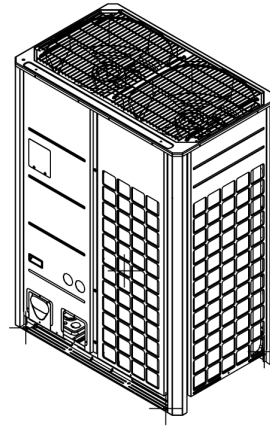
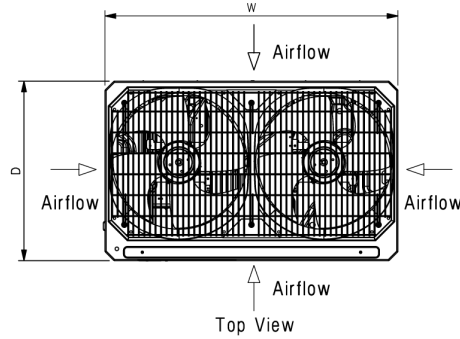

W	48-13/16"
H	66-17/32"
D	29-29/32"
L1	6-5/16"
L2	3-3/4"
L3	5-29/32"
L4	5-13/32"
L5	2-25/32"
L6	24-9/32"
L7	2-25/32"
L8	4-1/32"
L9	6-1/2"
L10	5-9/16"
L11	8-5/8"
L12	6-7/16"
L13	9-15/16"
L14	3-5/8"

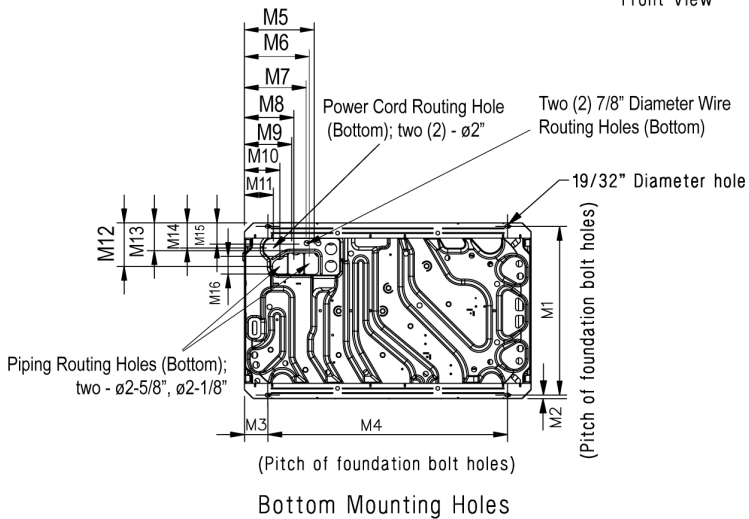
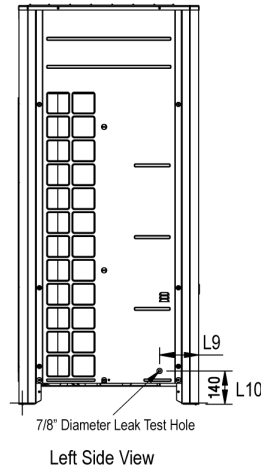
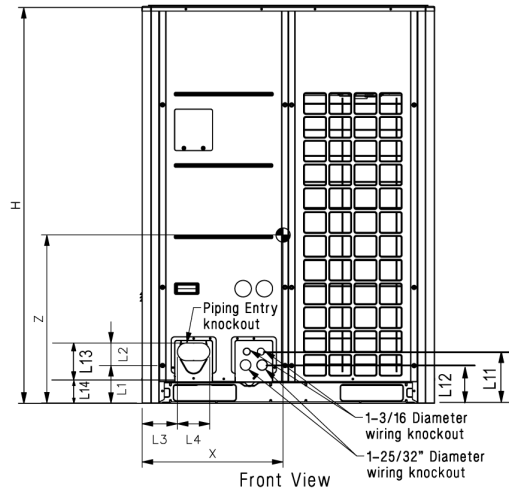
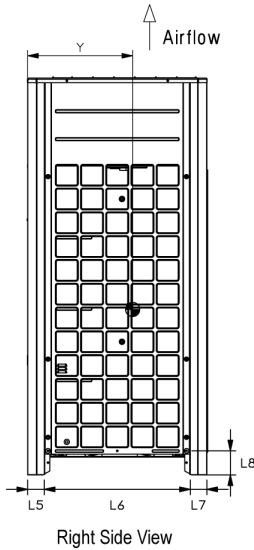

M1	28-25/32"
M2	5/8"
M3	3-15/16"
M4	40-15/16"
M5	11-15/16"
M6	11-1/16"
M7	10-1/2"
M8	8-7/16"
M9	8-1/8"
M10	6-1/16"
M11	4-15/16"
M12	7-1/2"
M13	4-13/16"
M14	4-5/16"
M15	3-5/8"
M16	3"

Center of Gravity

X	23-7/32"
Y	15-5/8"
Z	25-9/16"

All dimensions have a tolerance of ± 0.25 in.  
[Unit: inch]

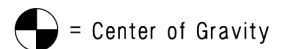

**ARUM144DTE5**  
 Multi V™ 5 with LGRED° 460V ODU  
 12 Ton Single Frame Heat Pump and Heat Recovery



Tag No.: \_\_\_\_\_

Date: 7/24/2023

PO No.: \_\_\_\_\_

**AHRI Data:**

Reference Number	Indoor Type	Cooling Capacity (95°F)	EER (95°F)	IEER	SCHE	High Heating Capacity (47°F)	High COP (47°F)	Low Heating Capacity (17°F)	Low COP (17°F)
205281467	Ducted Indoor Units	138,000	12.10	23.00	25.90	152,000	3.52	98,000	2.48
202524545	Non-Ducted Indoor Units	138,000	12.50	28.60	27.50	152,000	3.84	98,000	2.67

**Date:** 7/24/2023

**For:**  File  Resubmit  
 Approval  Other \_\_\_\_\_

**PO No.:**

**Architect:** Lewis Architects and Engineers

**GC:** TBD

**Engr:** Lewis Architects and Engineers

**Mech:** Comfort Systems USA

**Rep:** Airetech Corporation  
 (Company)

Nick Moore  
 (Project Manager)

**ARUM168DTE5**  
**Multi V™ 5 with LGRED° 460V ODU**  
**14 Ton Single Frame Heat Pump and Heat Recovery**



**Performance:**

Cooling Mode:

Nominal Capacity (Btu/h)	168,000
Power Input (kW)	12.23

Heating Mode:

Nominal Capacity (Btu/h)	189,000
Power Input (kW)	13.98

Rated capacity is certified under AHRI Standard 1230. Ratings are subject to change without notice. Current certified ratings are available at [www.ahridirectory.org](http://www.ahridirectory.org).

**Electrical:**

Frame	ARUM168DTE5
Power Supply (V/Hz/Ø) <sup>1</sup>	460/60/3
MOP (A)	35
MCA (A)	28.5
Rated Amps (A)	25.6
Compressor A (A)	11.4
Compressor B (B)	9.2
Fan (A)	5.0

**Piping:<sup>2</sup>**

Frame	ARUM168DTE5
Refrigerant Charge (lbs.)	26.5
Liquid (in., O.D.)	5/8 Braze
High Pressure Vapor (Heat Recov only; in., O.D.)	7/8 Braze
Low Pressure Vapor (in., O.D.)	1-1/8 Braze

**Standard Features:**

- Advanced Smart Load Control
- Intelligent Heating
- HiPOR (High Pressure Oil Return)
- Smart Oil Control
- Night Quiet Operation
- Fault Detection and Diagnosis
- Active Refrigerant Control
- Variable Heat Path Exchanger
- Subcooling and Vapor Injection Control
- Liquid Cooled Inverter Controller
- Advanced Comfort Cooling

**Optional Accessories:**

- Air Guide - ZAGDKA52A
- Hail Guard Kit - ZHGDKA52A
- Low Ambient Baffle Kit - ZLABKA52A (2), Control Kit - PRVC2 (1 per system)
- Base Pan Heater - ZPLT2A51A

\*\*Cooling range with the Low Ambient Baffle Kit (sold separately) is -9.9°F to +122°F and is achieved only when all indoor units are operating in cooling mode. Does not impact heat recovery system synchronous operating range.

For continual product development, LG reserves the right to change specifications without notice.

© LG Electronics U.S.A., Inc., Englewood Cliffs, NJ. All rights reserved. "LG Life's Good" is a registered trademark of LG Corp. /www.lghvac.com

**Operating Range:**

Cooling (°F DB)**	5 - 122
Heating (°F WB)	-22 - 61
Synchronous	
Cooling Based (°F DB)	14 - 81
Heating Based (°F WB)	14 - 61

**Unit Data:**

Refrigerant Type	R410A
Refrigerant Control	EEV
Max. Number of Indoor Units <sup>3</sup>	29
Sound Pressure <sup>4</sup> dB(A)	61.0
Weight	
Frame	ARUM168DTE5
Net (lbs.)	639
Shipping (lbs.)	666
Communication Cable (No x AWG) <sup>5</sup>	2 x 18
Heat Exchanger Coating	Black Coated Fin™

**Compressor:**

Type	HSS DC Scroll
Quantity	2
Oil / Type	PVE / FVC68D

**Fan:**

Type	Propeller
Quantity	2
Motor Drive	Brushless Digitally Controlled Direct
Air Flow Rate (rated/max, CFM)	10,300 / 11,300

**Notes:**

1. Power wiring cable size must comply with the applicable local and national codes. Cables terminate at each frame.
2. For main pipe segment size, refer to the LATS Multi V tree diagram.
3. The combination ratio must be between 50-130%.
4. Sound pressure levels are tested in an anechoic chamber under ISO Standard 3745 for the combination of outdoor units.
5. Communication cable between ODU and IDUs must be 2-conductor, 18 AWG, twisted, stranded, and shielded. Ensure the communication cable shield is properly grounded to the Main ODU chassis only. Do not ground the communication cable at any other point. Wiring must comply with all applicable local and national codes.
6. Acceptable operating voltage: 414 - 528V
7. Fan ESP (in wg) selectable range is 0.16 to 0.32.



# ARUM168DTE5

Multi V™ 5 with LGRED® 460V ODU

14 Ton Single Frame Heat Pump and Heat Recovery



Tag No.:

Date: 7/24/2023

PO No.:

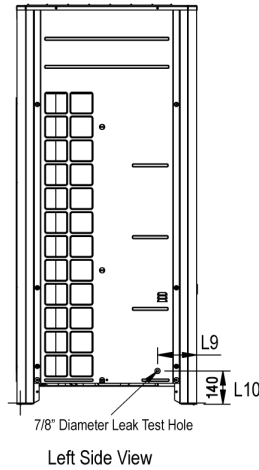
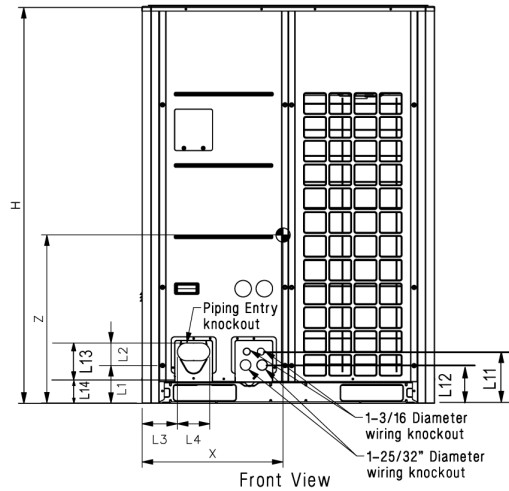
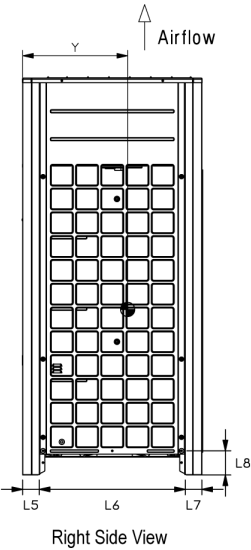
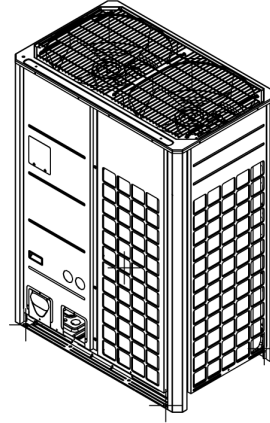
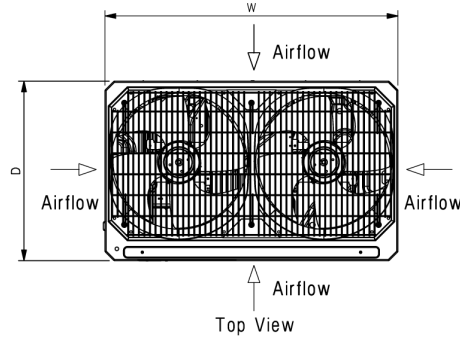

W	48-13/16"
H	66-17/32"
D	29-29/32"
L1	6-5/16"
L2	3-3/4"
L3	5-29/32"
L4	5-13/32"
L5	2-25/32"
L6	24-9/32"
L7	2-25/32"
L8	4-1/32"
L9	6-1/2"
L10	5-9/16"
L11	8-5/8"
L12	6-7/16"
L13	9-15/16"
L14	3-5/8"

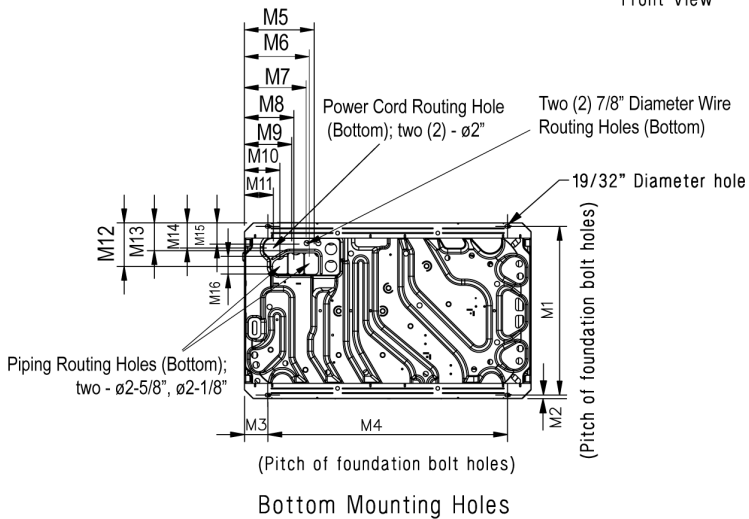

M1	28-25/32"
M2	5/8"
M3	3-15/16"
M4	40-15/16"
M5	11-15/16"
M6	11-1/16"
M7	10-1/2"
M8	8-7/16"
M9	8-1/8"
M10	6-1/16"
M11	4-15/16"
M12	7-1/2"
M13	4-13/16"
M14	4-5/16"
M15	3-5/8"
M16	3"

Center of Gravity

X	23-7/32"
Y	15-5/8"
Z	25-9/16"

All dimensions have a tolerance of ± 0.25 in.  
[Unit: inch]

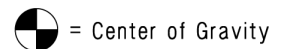

**ARUM168DTE5**  
**Multi V™ 5 with LGRED° 460V ODU**  
 14 Ton Single Frame Heat Pump and Heat Recovery



Tag No.: \_\_\_\_\_

Date: 7/24/2023

PO No.: \_\_\_\_\_

**AHRI Data:**

Reference Number	Indoor Type	Cooling Capacity (95°F)	EER (95°F)	IEER	SCHE	High Heating Capacity (47°F)	High COP (47°F)	Low Heating Capacity (17°F)	Low COP (17°F)
205281470	Ducted Indoor Units	160,000	11.10	21.90	23.60	180,000	3.20	117,000	2.38
202524547	Non-Ducted Indoor Units	160,000	11.70	25.40	27.00	180,000	3.57	117,000	2.45

**Date:** 7/24/2023

**For:**  File  Resubmit  
 Approval  Other \_\_\_\_\_

**PO No.:**

**Architect:** Lewis Architects and Engineers

**GC:** TBD

**Engr:** Lewis Architects and Engineers

**Mech:** Comfort Systems USA

**Rep:** Airetech Corporation  
 (Company)

Nick Moore  
 (Project Manager)

**ARUM241DTE5**  
**Multi V™ 5 with LGRED° 460V ODU**  
**20 Ton Single Frame Heat Pump and Heat Recovery**



**Operating Range:**

Cooling (°F DB)**	5 - 122
Heating (°F WB)	-22 - 61
Synchronous	
Cooling Based (°F DB)	14 - 81
Heating Based (°F WB)	14 - 61

**Performance:**

Cooling Mode:

Nominal Capacity (Btu/h)	233,100
Power Input (kW)	16.80

Heating Mode:

Nominal Capacity (Btu/h)	243,000
Power Input (kW)	17.75

Rated capacity is certified under AHRI Standard 1230. Ratings are subject to change without notice. Current certified ratings are available at [www.ahridirectory.org](http://www.ahridirectory.org).

**Electrical:**

Frame	ARUM241DTE5
Power Supply (V/Hz/Ø) <sup>1</sup>	460/60/3
MOP (A)	50
MCA (A)	41.4
Rated Amps (A)	37.2
Compressor A (A)	16.9
Compressor B (B)	15.3
Fan (A)	5.0

**Unit Data:**

Refrigerant Type	R410A
Refrigerant Control	EEV
Max. Number of Indoor Units <sup>3</sup>	39
Sound Pressure <sup>4</sup> dB(A)	65.0
Weight	
Frame	ARUM241DTE5
Net (lbs.)	666
Shipping (lbs.)	694
Communication Cable (No x AWG) <sup>5</sup>	2 x 18
Heat Exchanger Coating	Black Coated Fin™

**Compressor:**

Type	HSS DC Scroll
Quantity	2
Oil / Type	PVE / FVC68D

**Fan:**

Type	Propeller
Quantity	2
Motor Drive	Brushless Digitally Controlled Direct
Air Flow Rate (rated/max, CFM)	10,300 / 11,300

**Piping:<sup>2</sup>**

Frame	ARUM241DTE5
Refrigerant Charge (lbs.)	37.5
Liquid (in., O.D.)	5/8 Braze
High Pressure Vapor (Heat Recov only; in, O.D.)	1-1/8 Braze
Low Pressure Vapor (in., O.D.)	1-3/8 Braze

**Standard Features:**

- Advanced Smart Load Control
- Intelligent Heating
- HiPOR (High Pressure Oil Return)
- Smart Oil Control
- Night Quiet Operation
- Fault Detection and Diagnosis
- Active Refrigerant Control
- Variable Heat Path Exchanger
- Subcooling and Vapor Injection Control
- Liquid Cooled Inverter Controller
- Advanced Comfort Cooling

**Optional Accessories:**

- Air Guide - ZAGDKA52A
- Hail Guard Kit - ZHGDKA52A
- Low Ambient Baffle Kit - ZLABKA52A (2), Control Kit - PRVC2 (1 per system)
- Base Pan Heater - ZPLT2A51A

\*\*Cooling range with the Low Ambient Baffle Kit (sold separately) is -9.9°F to +122°F and is achieved only when all indoor units are operating in cooling mode. Does not impact heat recovery system synchronous operating range.

**Notes:**

1. Power wiring cable size must comply with the applicable local and national codes. Cables terminate at each frame.
2. For main pipe segment size, refer to the LATS Multi V tree diagram.
3. The combination ratio must be between 50-130%.
4. Sound pressure levels are tested in an anechoic chamber under ISO Standard 3745 for the combination of outdoor units.
5. Communication cable between ODU and IDUs must be 2-conductor, 18 AWG, twisted, stranded, and shielded. Ensure the communication cable shield is properly grounded to the Main ODU chassis only. Do not ground the communication cable at any other point. Wiring must comply with all applicable local and national codes.
6. Acceptable operating voltage: 414 - 528V
7. Fan ESP (in wg) selectable range is 0.16 to 0.32.



# ARUM241DTE5

Multi V™ 5 with LGRED® 460V ODU

20 Ton Single Frame Heat Pump and Heat Recovery



Tag No.: \_\_\_\_\_

Date: 7/24/2023

PO No.: \_\_\_\_\_

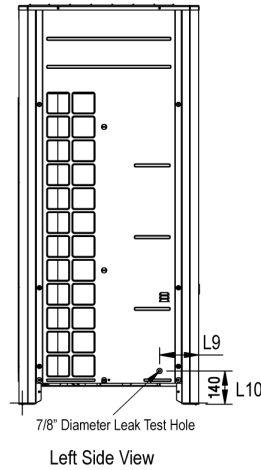
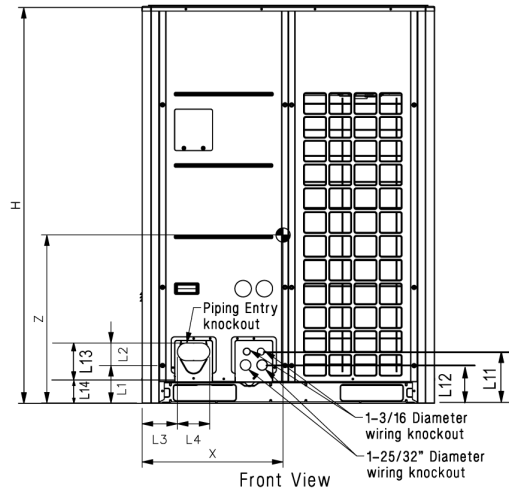
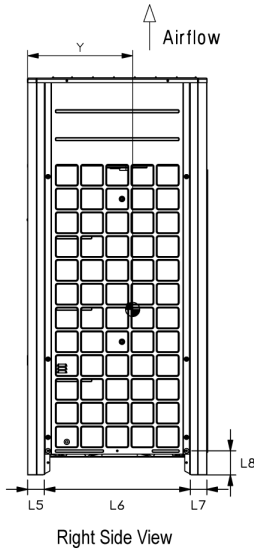
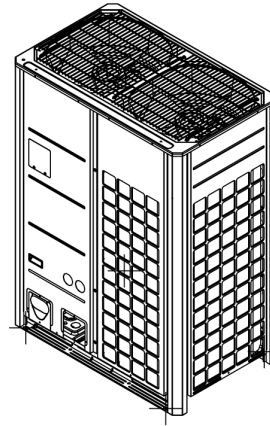
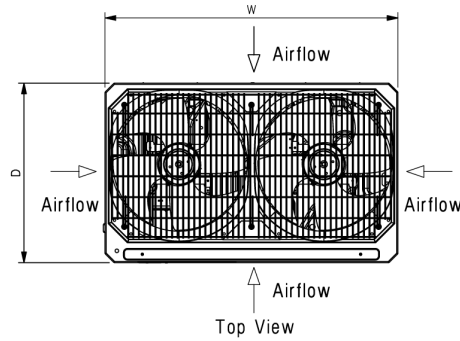

W	48-13/16"
H	66-17/32"
D	29-29/32"
L1	6-5/16"
L2	3-3/4"
L3	5-29/32"
L4	5-13/32"
L5	2-25/32"
L6	24-9/32"
L7	2-25/32"
L8	4-1/32"
L9	6-1/2"
L10	5-9/16"
L11	8-5/8"
L12	6-7/16"
L13	9-15/16"
L14	3-5/8"

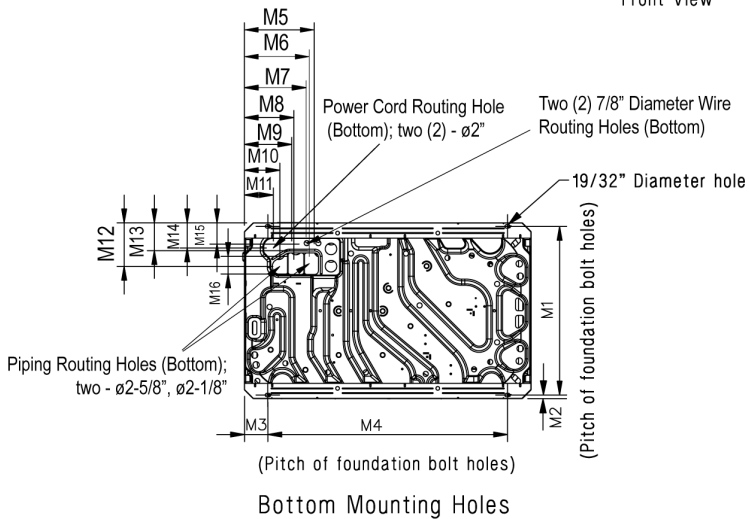

M1	28-25/32"
M2	5/8"
M3	3-15/16"
M4	40-15/16"
M5	11-15/16"
M6	11-1/16"
M7	10-1/2"
M8	8-7/16"
M9	8-1/8"
M10	6-1/16"
M11	4-15/16"
M12	7-1/2"
M13	4-13/16"
M14	4-5/16"
M15	3-5/8"
M16	3"

Center of Gravity

X	23-7/32"
Y	15-5/8"
Z	25-9/16"

All dimensions have a tolerance of ± 0.25 in.  
[Unit: inch]

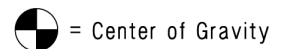

**ARUM241DTE5**  
**Multi V™ 5 with LGRED° 460V ODU**  
 20 Ton Single Frame Heat Pump and Heat Recovery



Tag No.: \_\_\_\_\_

Date: 7/24/2023

PO No.: \_\_\_\_\_

**AHRI Data:**

Reference Number	Indoor Type	Cooling Capacity (95°F)	EER (95°F)	IEER	SCHE	High Heating Capacity (47°F)	High COP (47°F)	Low Heating Capacity (17°F)	Low COP (17°F)
205281452	Ducted Indoor Units	222,000	10.40	22.70	23.00	230,000	3.20	168,000	2.26
202524553	Non-Ducted Indoor Units	222,000	10.40	22.50	26.00	230,000	3.35	168,000	2.52

**Date:** 7/24/2023

**For:**  File  Resubmit  
 Approval  Other

**PO No.:**

**Architect:** Lewis Architects and Engineers

**GC:** TBD

**Engr:** Lewis Architects and Engineers

**Mech:** Comfort Systems USA

**Rep:** Airetech Corporation  
 (Company)

Nick Moore  
 (Project Manager)

**ARUM264DTE5** (a) ARUM096DTE5  
**Multi V™ 5 with LGRED° 460V ODU** (b) ARUM168DTE5  
**22 Ton Dual Frame Heat Pump and Heat Recovery**



**Performance:**

Cooling Mode:

Nominal Capacity (Btu/h)	264,000
Power Input <sup>1</sup> (kW)	17.56

Heating Mode:

Nominal Capacity (Btu/h)	297,000
Power Input <sup>1</sup> (kW)	20.72

Rated capacity is certified under AHRI Standard 1230. Ratings are subject to change without notice. Current certified ratings are available at [www.ahridirectory.org](http://www.ahridirectory.org).

**Electrical:**

Frame	(a) ARUM096DTE5	(b) ARUM168DTE5
Power Supply (V/Hz/Ø) <sup>1</sup>	460/60/3	460/60/3
MOP (A)	25	35
MCA (A)	16.4	28.5
Rated Amps (A)	14.1	25.6
Compressor A (A)	9.1	11.4
Compressor B (B)	-	9.2
Fan (A)	5.0	5.0

**Piping:<sup>2</sup>**

Frame	(a) ARUM096DTE5	(b) ARUM168DTE5
Refrigerant Charge (lbs.)	23.2	26.5
Liquid (in., O.D.)	3/8 Braze	5/8 Braze
High Pressure Vapor (Heat Recovery only; in, O.D.)	3/4 Braze	7/8 Braze
Low Pressure Vapor (in., O.D.)	7/8 Braze	1-1/8 Braze

**Standard Features:**

- Advanced Smart Load Control
- Intelligent Heating
- HiPOR (High Pressure Oil Return)
- Smart Oil Control
- Night Quiet Operation
- Fault Detection and Diagnosis
- Active Refrigerant Control
- Variable Heat Path Exchanger
- Subcooling and Vapor Injection Control
- Liquid Cooled Inverter Controller
- Advanced Comfort Cooling

**Required Accessories:**

- ARCNCB21 (Frame Connector Y-branch, 3 pipe heat recovery)
- ARCNCN21 (Frame Connector Y-branch, 2 pipe heat pump)

**Optional Accessories:**

- Air Guide - ZAGDKA52A (2 required)
- Hail Guard Kit - ZHGDKA52A (2 required)
- Low Ambient Baffle Kit - ZLABKA52A (2), Control Kit - PRVC2 (1 per system)
- Base Pan Heater - ZPLT2A52A

\*\*Cooling range with the Low Ambient Baffle Kit (sold separately) is -9.9°F to +122°F and is achieved only when all indoor units are operating in cooling mode. Does not impact heat recovery system synchronous operating range.

For continual product development, LG reserves the right to change specifications without notice.

© LG Electronics U.S.A., Inc., Englewood Cliffs, NJ. All rights reserved. "LG Life's Good" is a registered trademark of LG Corp. /www.lghvac.com

**Operating Range:**

Cooling (°F DB)**	5 - 122
Heating (°F WB)	-22 - 61
Synchronous	
Cooling Based (°F DB)	14 - 81
Heating Based (°F WB)	14 - 61

**Unit Data:**

Refrigerant Type	R410A
Refrigerant Control	EEV
Max. Number of Indoor Units <sup>3</sup>	42
Sound Pressure <sup>4</sup> dB(A)	63.0
Weight	
Frame	(a) ARUM096DTE5 (b) ARUM168DTE5
Net (lbs.)	507 639
Shipping (lbs.)	534 666
Communication Cable (No x AWG) <sup>5</sup>	2 x 18
Heat Exchanger Coating	Black Coated Fin™

**Compressor:**

Type	HSS DC Scroll
Quantity	3
Oil / Type	PVE / FVC68D

**Fan:**

Type	Propeller
Quantity (a) + (b)	4
Motor Drive	Brushless Digitally Controlled Direct
Air Flow Rate (a) + (b) (rated/max, CFM)	17,700 / 22,600

**Notes:**

1. Power wiring cable size must comply with the applicable local and national codes. Cables terminate at each frame.
2. For main pipe segment size, refer to the LATS Multi V tree diagram.
3. The combination ratio must be between 50-130%.
4. Sound pressure levels are tested in an anechoic chamber under ISO Standard 3745 for the combination of outdoor units.
5. Communication cable between ODU and IDUs must be 2-conductor, 18 AWG, twisted, stranded, and shielded. Ensure the communication cable shield is properly grounded to the Main ODU chassis only. Do not ground the communication cable at any other point. Wiring must comply with all applicable local and national codes.
6. Acceptable operating voltage: 414-528V
7. The order of these units on the submittal (i.e., a+b) does not represent the installation order. Highest capacity unit is used as the Main, followed by the smaller size as Sub 1.
8. Fan ESP (in wg) selectable range is 0.16 to 0.32.



# ARUM264DTE5

Multi V™ 5 with LGRED° 460V ODU

22 Ton Dual Frame Heat Pump and Heat Recovery

(a) ARUM096DTE5

(b) ARUM168DTE5



Tag No.: \_\_\_\_\_

Date: 7/24/2023

PO No.: \_\_\_\_\_

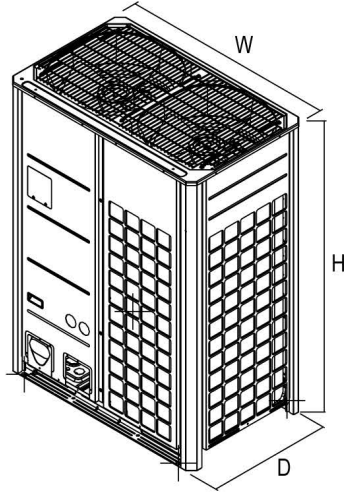

Typical Dual Frame Configuration

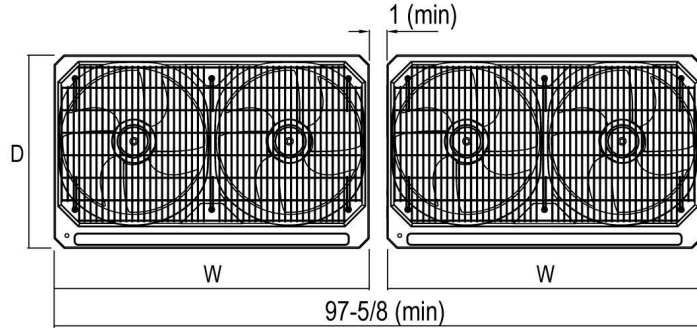

**Note:** Please refer to multi-frame placement information and piping rules in the Multi V 5 Engineering Manual and the Multi V 5 Installation Manual. Minimum spacing between frames is 1 inch.

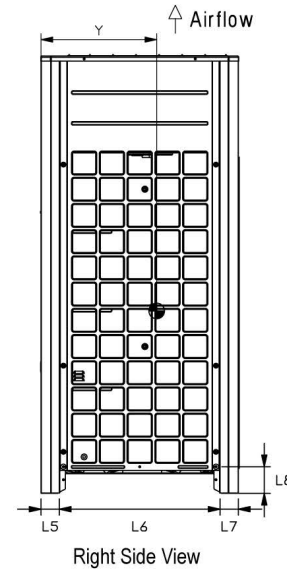
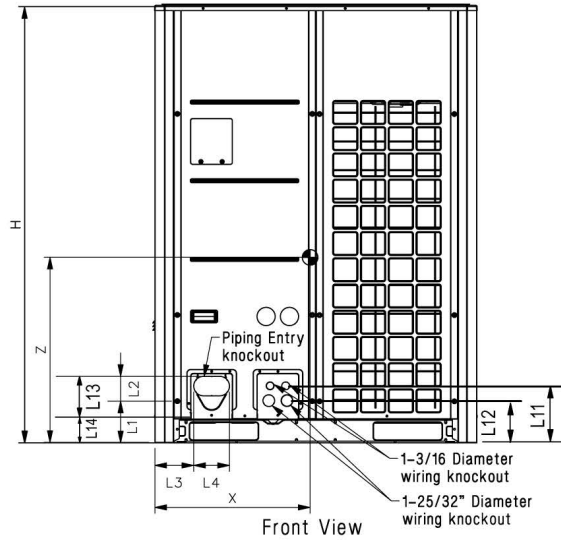
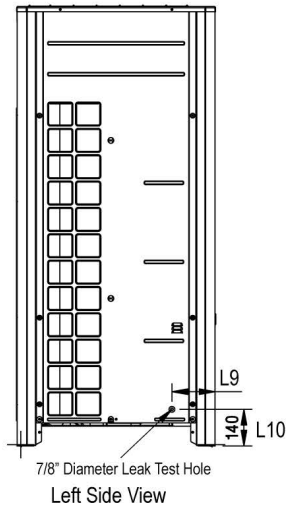

W	48-13/16"
H	66-17/32"
D	29-29/32"
L1	6-5/16"
L2	3-3/4"
L3	5-29/32"
L4	5-13/32"
L5	2-25/32"
L6	24-9/32"
L7	2-25/32"
L8	4-1/32"
L9	6-1/2"
L10	5-9/16"
L11	8-5/8"
L12	6-7/16"
L13	9-15/16"
L14	3-5/8"

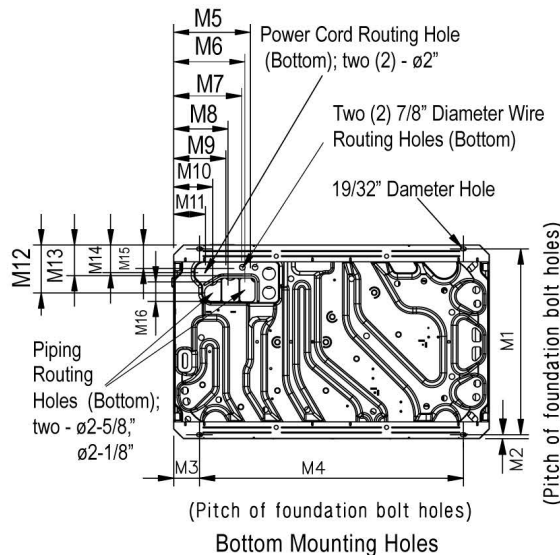
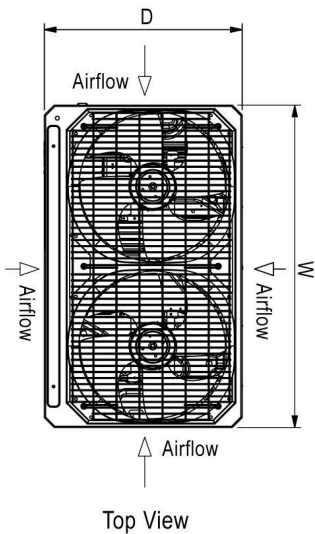

M1	28-25/32"
M2	5/8"
M3	3-15/16"
M4	40-15/16"
M5	11-15/16"
M6	11-1/16"
M7	10-1/2"
M8	8-7/16"
M9	8-1/8"
M10	6-1/16"
M11	4-15/16"
M12	7-1/2"
M13	4-13/16"
M14	4-5/16"
M15	3-5/8"
M16	3"

Center of Gravity

X	23-7/32"
Y	15-5/8"
Z	25-9/16"

All dimensions have a tolerance of  $\pm 0.25$  in. [Unit: inch]



**ARUM264DTE5**

Multi V™ 5 with LGRED° 460V ODU

22 Ton Dual Frame Heat Pump and Heat Recovery



Tag No.: \_\_\_\_\_

Date: 7/24/2023

PO No.: \_\_\_\_\_

**AHRI Data:**

Reference Number	Indoor Type	Cooling Capacity (95°F)	EER (95°F)	IEER	SCHE	High Heating Capacity (47°F)	High COP (47°F)	Low Heating Capacity (17°F)	Low COP (17°F)
205281479	Ducted Indoor Units	252,000	11.50	21.50	24.60	282,000	3.38	182,000	2.38
202524555	Non-Ducted Indoor Units	252,000	12.50	22.00	25.00	282,000	3.56	182,000	2.52

**Date:** 7/24/2023

**For:**  File  Resubmit  
 Approval  Other

**PO No.:**

**Architect:** Lewis Architects and Engineers

**GC:** TBD

**Engr:** Lewis Architects and Engineers

**Mech:** Comfort Systems USA

**Rep:** Airetech Corporation  
 (Company)

Nick Moore  
 (Project Manager)

**ARUM312DTE5** (a) ARUM096DTE5  
**Multi V™ 5 with LGRED° 460V ODU** (b) ARUM216DTE5  
**26 Ton Dual Frame Heat Pump and Heat Recovery**



**Performance:**

Cooling Mode:

Nominal Capacity (Btu/h)	312,000
Power Input <sup>1</sup> (kW)	20.70

Heating Mode:

Nominal Capacity (Btu/h)	351,000
Power Input <sup>1</sup> (kW)	24.49

Rated capacity is certified under AHRI Standard 1230. Ratings are subject to change without notice. Current certified ratings are available at [www.ahridirectory.org](http://www.ahridirectory.org).

**Electrical:**

Frame	(a) ARUM096DTE5	(b) ARUM216DTE5
Power Supply (V/Hz/Ø) <sup>1</sup>	460/60/3	460/60/3
MOP (A)	25	50
MCA (A)	16.4	38.3
Rated Amps (A)	14.1	34.4
Compressor A (A)	9.1	15.5
Compressor B (B)	-	13.9
Fan (A)	5.0	5.0

**Piping:<sup>2</sup>**

Frame	(a) ARUM096DTE5	(b) ARUM216DTE5
Refrigerant Charge (lbs.)	23.2	37.5
Liquid (in., O.D.)	3/8 Braze	5/8 Braze
High Pressure Vapor (Heat Recovery only; in, O.D.)	3/4 Braze	1-1/8 Braze
Low Pressure Vapor (in., O.D.)	7/8 Braze	1-1/8 Braze

**Standard Features:**

- Advanced Smart Load Control
- Intelligent Heating
- HiPOR (High Pressure Oil Return)
- Smart Oil Control
- Night Quiet Operation
- Fault Detection and Diagnosis
- Active Refrigerant Control
- Variable Heat Path Exchanger
- Subcooling and Vapor Injection Control
- Liquid Cooled Inverter Controller
- Advanced Comfort Cooling

**Required Accessories:**

- ARCNCB21 (Frame Connector Y-branch, 3 pipe heat recovery)
- ARCNCN21 (Frame Connector Y-branch, 2 pipe heat pump)

**Optional Accessories:**

- Air Guide - ZAGDKA52A (2 required)
- Hail Guard Kit - ZHGDKA52A (2 required)
- Low Ambient Baffle Kit - ZLABKA52A (2), Control Kit - PRVC2 (1 per system)
- Base Pan Heater - ZPLT2A52A

\*\*Cooling range with the Low Ambient Baffle Kit (sold separately) is -9.9°F to +122°F and is achieved only when all indoor units are operating in cooling mode. Does not impact heat recovery system synchronous operating range.

For continual product development, LG reserves the right to change specifications without notice.

© LG Electronics U.S.A., Inc., Englewood Cliffs, NJ. All rights reserved. "LG Life's Good" is a registered trademark of LG Corp. /www.lghvac.com

**Operating Range:**

Cooling (°F DB)**	5 - 122
Heating (°F WB)	-22 - 61
Synchronous	
Cooling Based (°F DB)	14 - 81
Heating Based (°F WB)	14 - 61

**Unit Data:**

Refrigerant Type	R410A
Refrigerant Control	EEV
Max. Number of Indoor Units <sup>3</sup>	52
Sound Pressure <sup>4</sup> dB(A)	65.0
Weight	
Frame	(a) ARUM096DTE5 (b) ARUM216DTE5
Net (lbs.)	507 666
Shipping (lbs.)	534 694
Communication Cable (No x AWG) <sup>5</sup>	2 x 18
Heat Exchanger Coating	Black Coated Fin™

**Compressor:**

Type	HSS DC Scroll
Quantity	3
Oil / Type	PVE / FVC68D

**Fan:**

Type	Propeller
Quantity (a) + (b)	4
Motor Drive	Brushless Digitally Controlled Direct
Air Flow Rate (a) + (b) (rated/max, CFM)	17,700 / 22,600

**Notes:**

1. Power wiring cable size must comply with the applicable local and national codes. Cables terminate at each frame.
2. For main pipe segment size, refer to the LATS Multi V tree diagram.
3. The combination ratio must be between 50-130%.
4. Sound pressure levels are tested in an anechoic chamber under ISO Standard 3745 for the combination of outdoor units.
5. Communication cable between ODU and IDUs must be 2-conductor, 18 AWG, twisted, stranded, and shielded. Ensure the communication cable shield is properly grounded to the Main ODU chassis only. Do not ground the communication cable at any other point. Wiring must comply with all applicable local and national codes.
6. Acceptable operating voltage: 414-528V
7. The order of these units on the submittal (i.e., a+b) does not represent the installation order. Highest capacity unit is used as the Main, followed by the smaller size as Sub 1.
8. Fan ESP (in wg) selectable range is 0.16 to 0.32.



# ARUM312DTE5

Multi V™ 5 with LGRED° 460V ODU

26 Ton Dual Frame Heat Pump and Heat Recovery

(a) ARUM096DTE5

(b) ARUM216DTE5



Tag No.: \_\_\_\_\_

Date: 7/24/2023

PO No.: \_\_\_\_\_

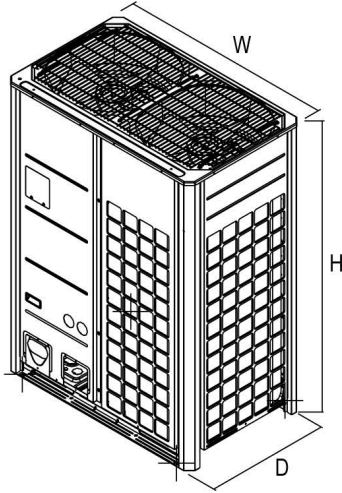

Typical Dual Frame Configuration

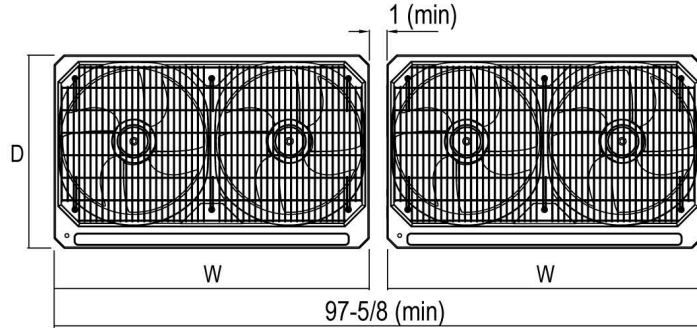

**Note:** Please refer to multi-frame placement information and piping rules in the Multi V 5 Engineering Manual and the Multi V 5 Installation Manual. Minimum spacing between frames is 1 inch.

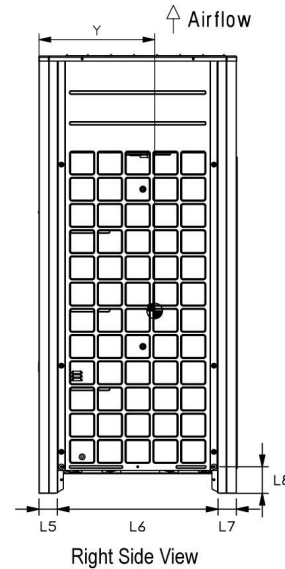
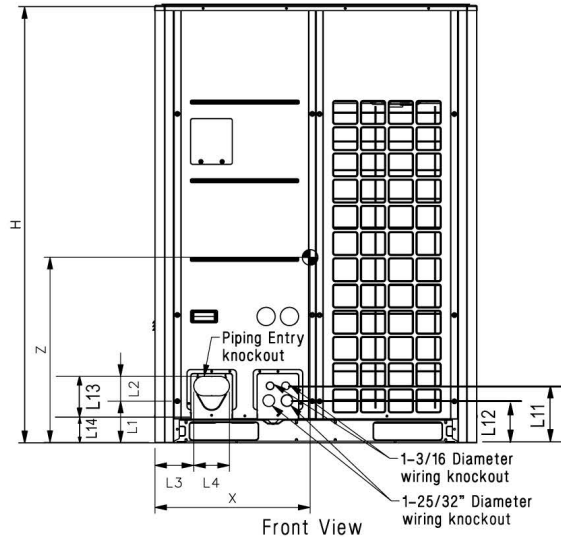
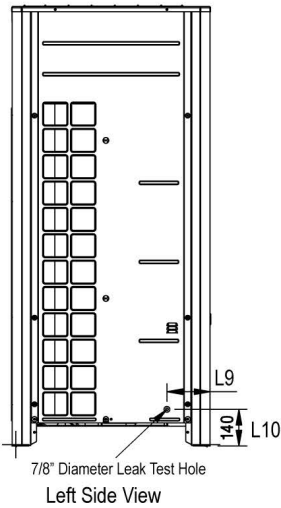

W	48-13/16"
H	66-17/32"
D	29-29/32"
L1	6-5/16"
L2	3-3/4"
L3	5-29/32"
L4	5-13/32"
L5	2-25/32"
L6	24-9/32"
L7	2-25/32"
L8	4-1/32"
L9	6-1/2"
L10	5-9/16"
L11	8-5/8"
L12	6-7/16"
L13	9-15/16"
L14	3-5/8"

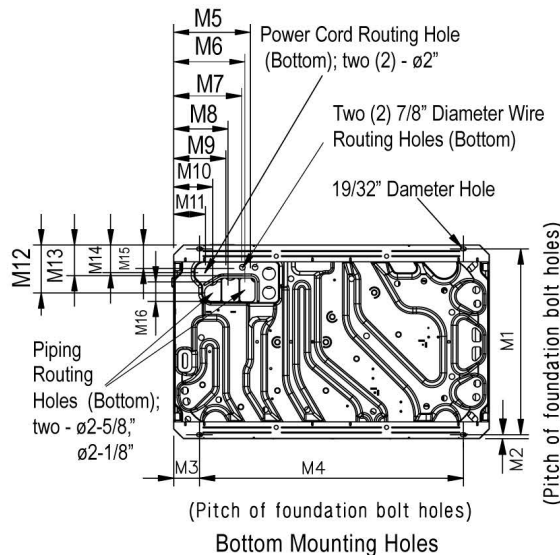
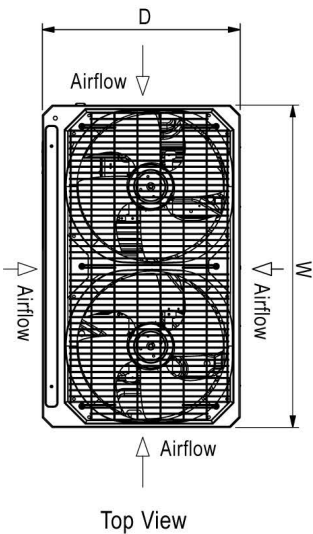

M1	28-25/32"
M2	5/8"
M3	3-15/16"
M4	40-15/16"
M5	11-15/16"
M6	11-1/16"
M7	10-1/2"
M8	8-7/16"
M9	8-1/8"
M10	6-1/16"
M11	4-15/16"
M12	7-1/2"
M13	4-13/16"
M14	4-5/16"
M15	3-5/8"
M16	3"

Center of Gravity

X	23-7/32"
Y	15-5/8"
Z	25-9/16"

All dimensions have a tolerance of  $\pm 0.25$  in. [Unit: inch]



**ARUM312DTE5**

Multi V™ 5 with LGRED° 460V ODU

26 Ton Dual Frame Heat Pump and Heat Recovery



Tag No.: \_\_\_\_\_

Date: 7/24/2023

PO No.: \_\_\_\_\_

**AHRI Data:**

Reference Number	Indoor Type	Cooling Capacity (95°F)	EER (95°F)	IEER	SCHE	High Heating Capacity (47°F)	High COP (47°F)	Low Heating Capacity (17°F)	Low COP (17°F)
205281481	Ducted Indoor Units	298,000	11.00	21.00	21.00	332,000	3.25	222,000	2.30
202524559	Non-Ducted Indoor Units	298,000	11.00	22.00	24.00	332,000	3.53	222,000	2.48

**Date:** 7/24/2023

**For:**  File  Resubmit

**PO No.:**

Approval  Other\_\_\_\_\_

**Architect:** Lewis Architects and Engineers

**GC:** TBD

**Engr:** Lewis Architects and Engineers

**Mech:** Comfort Systems USA

**Rep:** Airetech Corporation  
(Company)

Nick Moore  
(Project Manager)



**PRHR023A**  
**Multi V™ Heat Recovery Unit**  
Two (2) Port

**Performance:**

Maximum Port Capacity Btu/h (each port) <sup>1,2</sup>	60,000
Maximum Unit Capacity Btu/h (sum of ports)	120,000
Number of Indoor Unit Ports	2
Max. Connectible Number of Indoor Units	16
Max. Connectible Number of Indoor Units per Branch	8
Power Input <sup>3</sup>	
Cooling	39.8
Heating	37.2

**Electrical:**<sup>3</sup>

Power Supply (V/Hz/Ø)	208-230/60/1
Rated Amps	0.06

**Refrigerant Piping:**<sup>4</sup>

Port Liquid Line (in., O.D.)	3/8
Port Vapor Line (in., O.D.)	5/8
System Liquid Line (in., O.D.)	3/8
System Vapor Line High (in., O.D.)	3/4
System Vapor Line Low (in., O.D.)	7/8

**Unit Data:**

Refrigerant Type	R410A
Refrigerant Control	EEV
Sound Pressure	
Cooling Mode dB(A)	31
Heating Mode dB(A)	31
Simultaneous dB(A)	38
Changeover Cooling to Heating	33
Changeover Heating to Cooling	38
Unit Net Weight (lbs.)	33
Unit Shipping Weight (lbs.)	46

**Features:**

- Allows connected indoor units to be in cooling or heating mode simultaneously.
- Internal components are insulated.
  - External casing insulation is not needed.<sup>4</sup>
  - Condensate drain not needed.
- High pressure vapor pipe strainer accessory not required.
- Factory installed indoor unit vapor pipe strainers.
- Series or parallel connection with additional heat recovery units.
- Flexible placement for service access or pipe routing.
- Access panels:
  - Top panel for EEV heads.
  - Rear panel for control access.
  - Bottom panel for refrigerant circuit.

**Notes:**

1. Each port can allow up to 8 indoor units with a maximum capacity of 60 MBh per port.
2. Multiple units installed on the same heat recovery port must operate in the same mode. Auto-changeover or Mode override is not possible.
3. Power wiring is field provided, and must comply with the applicable local and national codes.
4. All refrigerant piping requires insulation.
5. Communication cable between Main outdoor units to indoor units / heat recovery units to be 18 AWG, 2-conductor, twisted, stranded, shielded. Ensure the communication cable shield is properly grounded to the Main outdoor unit chassis only. ⚡ Do not ground the outdoor unit to indoor units / heat recovery units communication cable at any other point. Wiring must comply with all applicable local and national codes.
6. Kit components must be kept dry and free of debris before installation.
7. This unit comes with a dry nitrogen charge.
8. Must follow installation instructions in the applicable LG installation manual.



**PRHR023A**  
 Multi V™ Heat Recovery Unit  
 Two (2) Port



Tag No.: \_\_\_\_\_  
 Date: 7/24/2023  
 PO No.: \_\_\_\_\_

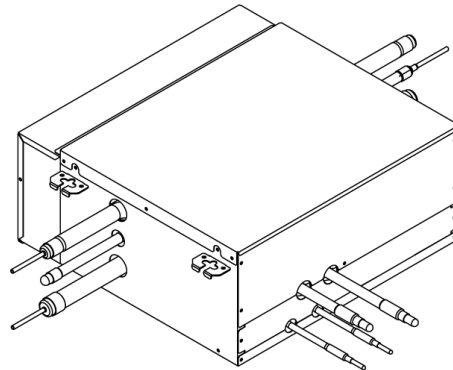
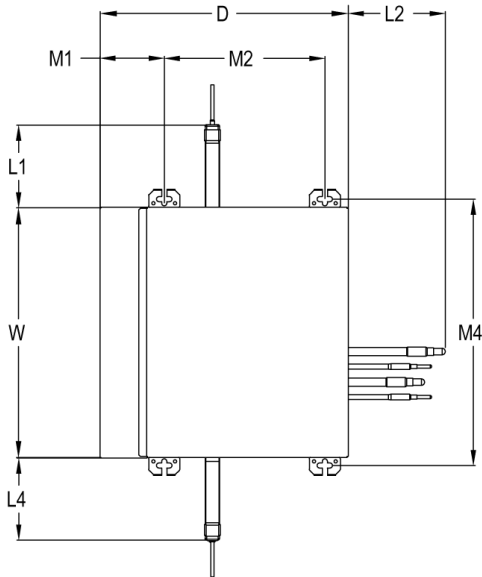

Strainers are factory installed on the indoor unit vapor piping.

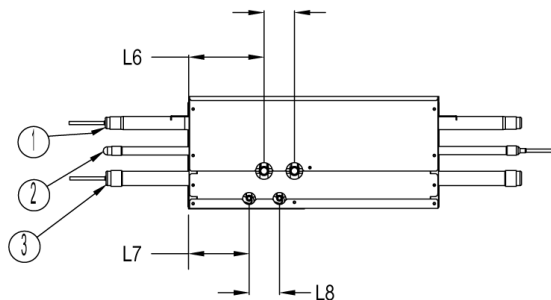
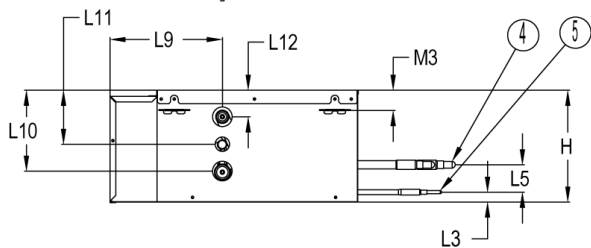

W	19-1/8"
H	8-5/8"
D	18-15/16"
L1	5-15/16"
L2	6-15/16"
L3	3/4"
L4	5-15/16"
L5	2-3/16"
L6	5-3/4"
L7	4-9/16"
L8	2-5/16"
L9	8-9/16"
L10	6-3/16"
L11	3-9/16"
L12	2"
M1	4-15/16"
M2	12-1/4"
M3	1-1/2"
M4	20-3/8"

[Unit: inch]

**Note:**

1. Unit should be installed in compliance with the appropriate LG installation manual.
2. Unit should be grounded in accordance with the local regulations or applicable national codes.
3. All electrical components and materials supplied from the site must comply with the local regulations or national codes.

6	Control box
5	Liquid pipe to Indoor unit
4	Vapor pipe to Indoor unit
3	Low pressure vapor pipe
2	Liquid pipe to Outdoor unit
1	High pressure vapor pipe
No.	Part Name

**Date:** 7/24/2023

**For:**  File  Resubmit

**PO No.:**

Approval  Other\_\_\_\_\_

**Architect:** Lewis Architects and Engineers

**GC:** TBD

**Engr:** Lewis Architects and Engineers

**Mech:** Comfort Systems USA

**Rep:** Airetech Corporation

Nick Moore

(Company)

(Project Manager)



**PRHR033A**  
Multi V™ Heat Recovery Unit  
Three (3) Port

**Performance:**

Maximum Port Capacity Btu/h (each port) <sup>1,2</sup>	60,000
Maximum Unit Capacity Btu/h (sum of ports)	180,000
Number of Indoor Unit Ports	3
Max. Connectible Number of Indoor Units	24
Max. Connectible Number of Indoor Units per Branch	8
Power Input <sup>3</sup>	
Cooling	39.8
Heating	37.2

**Electrical:**<sup>3</sup>

Power Supply (V/Hz/Ø)	208-230/60/1
Rated Amps	0.06

**Refrigerant Piping:**<sup>4</sup>

Port Liquid Line (in., O.D.)	3/8
Port Vapor Line (in., O.D.)	5/8
System Liquid Line (in., O.D.)	1/2
System Vapor Line High (in., O.D.)	7/8
System Vapor Line Low (in., O.D.)	1-1/8

**Unit Data:**

Refrigerant Type	R410A
Refrigerant Control	EEV
Sound Pressure	
Cooling Mode dB(A)	31
Heating Mode dB(A)	31
Simultaneous dB(A)	38
Changeover Cooling to Heating	33
Changeover Heating to Cooling	38
Unit Net Weight (lbs.)	37
Unit Shipping Weight (lbs.)	50

**Features:**

- Allows connected indoor units to be in cooling or heating mode simultaneously.
- Internal components are insulated.
  - External casing insulation is not needed.<sup>4</sup>
  - Condensate drain not needed.
- Includes high pressure vapor pipe strainer accessory.
- Factory installed indoor unit vapor pipe strainers.
- Series or parallel connection with additional heat recovery units.
- Flexible placement for service access or pipe routing.
- Access panels:
  - Top panel for EEV heads.
  - Rear panel for control access.
  - Bottom panel for refrigerant circuit.

**Notes:**

1. Each port can allow up to 8 indoor units with a maximum capacity of 60 MBh per port.
2. Multiple units installed on the same heat recovery port must operate in the same mode. Auto-changeover or Mode override is not possible.
3. Power wiring is field provided, and must comply with the applicable local and national codes.
4. All refrigerant piping requires insulation.
5. Communication cable between Main outdoor units to indoor units / heat recovery units to be 18 AWG, 2-conductor, twisted, stranded, shielded. Ensure the communication cable shield is properly grounded to the Main outdoor unit chassis only. Ⓞ Do not ground the outdoor unit to indoor units / heat recovery units communication cable at any other point. Wiring must comply with all applicable local and national codes.
6. Kit components must be kept dry and free of debris before installation.
7. This unit comes with a dry nitrogen charge.
8. Must follow installation instructions in the applicable LG installation manual.



**PRHR033A**  
 Multi V™ Heat Recovery Unit  
 Three (3) Port



Tag No.: \_\_\_\_\_  
 Date: 7/24/2023  
 PO No.: \_\_\_\_\_

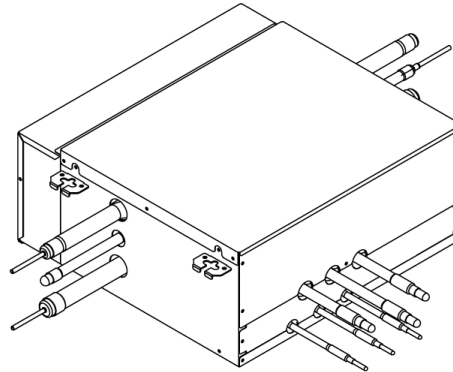
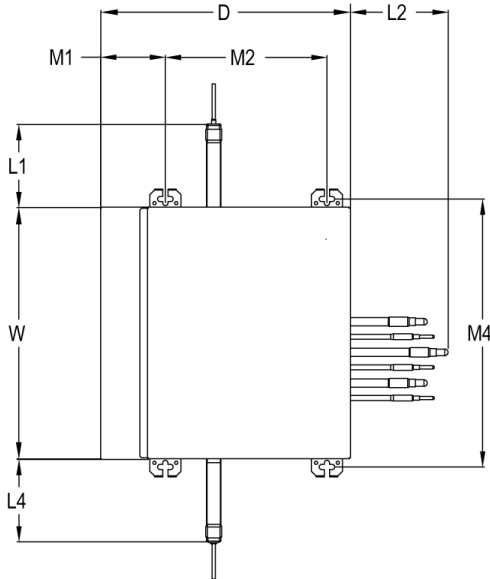

– Connect the strainer that is provided as an accessory to the HRU high pressure vapor pipe.  
 – Strainers are factory installed on the indoor unit vapor piping.

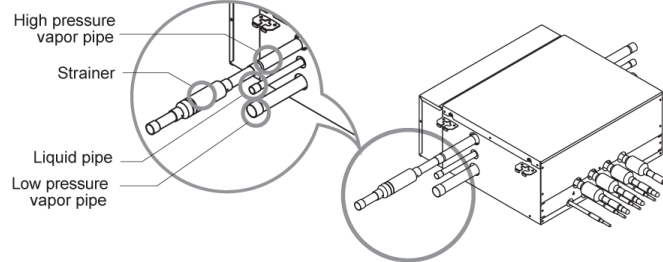

W	19-1/8"
H	8-5/8"
D	18-15/16"
L1	5-15/16"
L2	6-15/16"
L3	3/4"
L4	5-15/16"
L5	2-3/16"
L6	5-3/4"
L7	4-9/16"
L8	2-5/16"
L9	8-9/16"
L10	6-3/16"
L11	3-9/16"
L12	2"
M1	4-15/16"
M2	12-1/4"
M3	1-1/2"
M4	20-3/8"

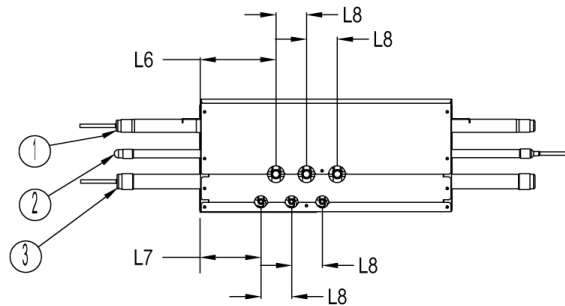
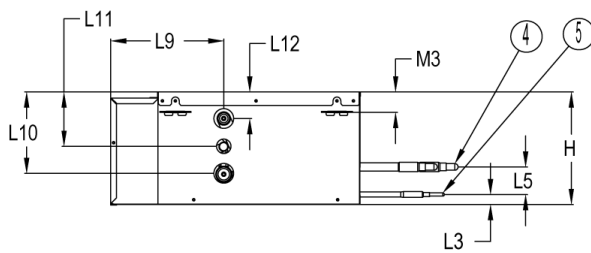

[Unit: inch]

**Note:**

1. Unit should be installed in compliance with the appropriate LG installation manual.
2. Unit should be grounded in accordance with the local regulations or applicable national codes.
3. All electrical components and materials supplied from the site must comply with the local regulations or national codes.

6	Control box
5	Liquid pipe to Indoor unit
4	Vapor pipe to Indoor unit
3	Low pressure vapor pipe
2	Liquid pipe to Outdoor unit
1	High pressure vapor pipe
No.	Part Name

**Date:** 7/24/2023

**For:**  File  Resubmit

**PO No.:**

Approval  Other\_\_\_\_\_

**Architect:** Lewis Architects and Engineers

**GC:** TBD

**Engr:** Lewis Architects and Engineers

**Mech:** Comfort Systems USA

**Rep:** Airetech Corporation

Nick Moore

(Company)

(Project Manager)



**PRHR043A**  
Multi V™ Heat Recovery Unit  
Four (4) Port

**Performance:**

Maximum Port Capacity Btu/h (each port) <sup>1,2</sup>	60,000
Maximum Unit Capacity Btu/h (sum of ports)	230,000
Number of Indoor Unit Ports	4
Max. Connectible Number of Indoor Units	32
Max. Connectible Number of Indoor Units per Branch	8
Power Input <sup>3</sup>	
Cooling	39.8
Heating	37.2

**Electrical:**<sup>3</sup>

Power Supply (V/Hz/Ø)	208-230/60/1
Rated Amps	0.06

**Refrigerant Piping:**<sup>4</sup>

Port Liquid Line (in., O.D.)	3/8
Port Vapor Line (in., O.D.)	5/8
System Liquid Line (in., O.D.)	5/8
System Vapor Line High (in., O.D.)	7/8
System Vapor Line Low (in., O.D.)	1-1/8

**Unit Data:**

Refrigerant Type	R410A
Refrigerant Control	EEV
Sound Pressure	
Cooling Mode dB(A)	31
Heating Mode dB(A)	31
Simultaneous dB(A)	38
Changeover Cooling to Heating	33
Changeover Heating to Cooling	38
Unit Net Weight (lbs.)	40
Unit Shipping Weight (lbs.)	53

**Features:**

- Allows connected indoor units to be in cooling or heating mode simultaneously.
- Internal components are insulated.
  - External casing insulation is not needed.<sup>4</sup>
  - Condensate drain not needed.
- Includes high pressure vapor pipe strainer accessory.
- Factory installed indoor unit vapor pipe strainers.
- Series or parallel connection with additional heat recovery units.
- Flexible placement for service access or pipe routing.
- Access panels:
  - Top panel for EEV heads.
  - Rear panel for control access.
  - Bottom panel for refrigerant circuit.

**Notes:**

1. Each port can allow up to 8 indoor units with a maximum capacity of 60 MBh per port.
2. Multiple units installed on the same heat recovery port must operate in the same mode. Auto-changeover or Mode override is not possible.
3. Power wiring is field provided, and must comply with the applicable local and national codes.
4. All refrigerant piping requires insulation.
5. Communication cable between Main outdoor units to indoor units / heat recovery units to be 18 AWG, 2-conductor, twisted, stranded, shielded. Ensure the communication cable shield is properly grounded to the Main outdoor unit chassis only. Ⓢ Do not ground the outdoor unit to indoor units / heat recovery units communication cable at any other point. Wiring must comply with all applicable local and national codes.
6. Kit components must be kept dry and free of debris before installation.
7. This unit comes with a dry nitrogen charge.
8. Must follow installation instructions in the applicable LG installation manual.



**PRHR043A**  
**Multi V™ Heat Recovery Unit**  
 Four (4) Port



Tag No.: \_\_\_\_\_

Date: 7/24/2023

PO No.: \_\_\_\_\_

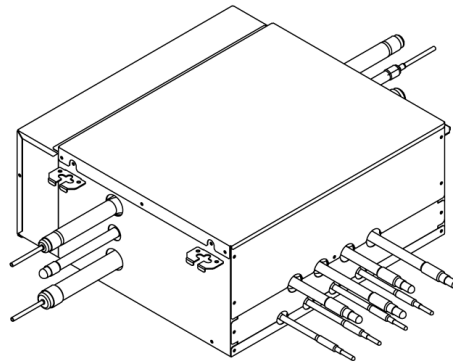
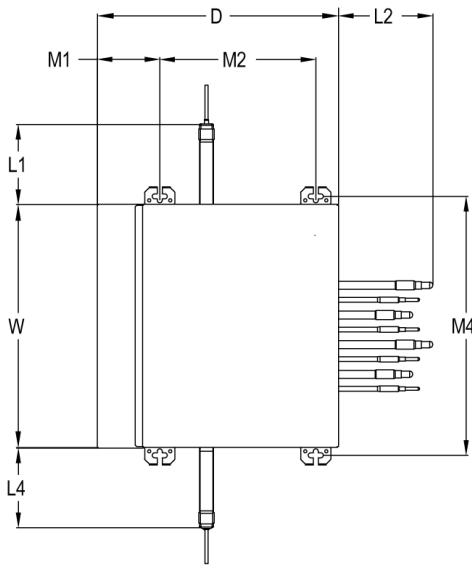

– Connect the strainer that is provided as an accessory to the HRU high pressure vapor pipe.  
 – Strainers are factory installed on the indoor unit vapor piping.

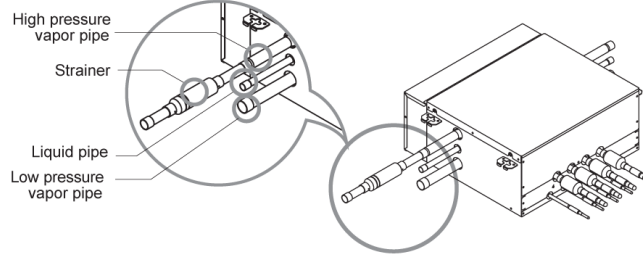

W	19-1/8"
H	8-5/8"
D	18-15/16"
L1	5-15/16"
L2	6-15/16"
L3	3/4"
L4	5-15/16"
L5	2-3/16"
L6	5-3/4"
L7	4-9/16"
L8	2-5/16"
L9	8-9/16"
L10	6-3/16"
L11	3-9/16"
L12	2"
M1	4-15/16"
M2	12-1/4"
M3	1-1/2"
M4	20-3/8"

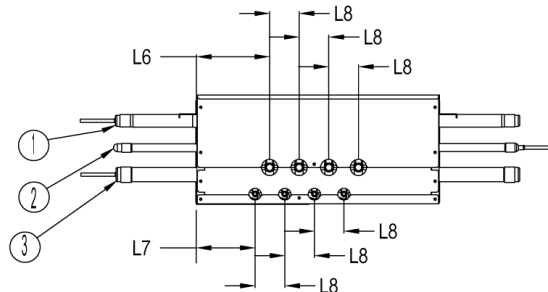
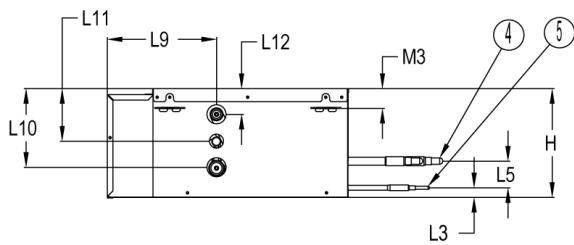

[Unit: inch]

**Note:**

- Unit should be installed in compliance with the appropriate LG installation manual.
- Unit should be grounded in accordance with the local regulations or applicable national codes.
- All electrical components and materials supplied from the site must comply with the local regulations or national codes.

6	Control box
5	Liquid pipe to Indoor unit
4	Vapor pipe to Indoor unit
3	Low pressure vapor pipe
2	Liquid pipe to Outdoor unit
1	High pressure vapor pipe
No.	Part Name

**Job Name/Location:** Southside HS and Jr High Additions

**Date:** 7/24/2023

**For:**  File  Resubmit

Approval  Other\_\_\_\_\_

**PO No.:**

**Architect:** Lewis Architects and Engineers

**GC:** TBD

**Engr:** Lewis Architects and Engineers

**Mech:** Comfort Systems USA

**Rep:** Airetech Corporation

Nick Moore

(Company)

(Project Manager)



**PRHR063A**  
Multi V™ Heat Recovery Unit  
Six (6) Port

**Performance:**

Maximum Port Capacity Btu/h (each port) <sup>1,2</sup>	60,000
Maximum Unit Capacity Btu/h (sum of ports)	230,000
Number of Indoor Unit Ports	6
Max. Connectible Number of Indoor Units	48
Max. Connectible Number of Indoor Units per Branch	8
Power Input <sup>3</sup>	
Cooling	75.9
Heating	72.1

**Electrical:<sup>3</sup>**

Power Supply (V/Hz/Ø)	208-230/60/1
Rated Amps	0.09

**Refrigerant Piping:<sup>4</sup>**

Port Liquid Line (in., O.D.)	3/8
Port Vapor Line (in., O.D.)	5/8
System Liquid Line (in., O.D.)	5/8
System Vapor Line High (in., O.D.)	7/8
System Vapor Line Low (in., O.D.)	1-1/8

**Unit Data:**

Refrigerant Type	R410A
Refrigerant Control	EEV
Sound Pressure	
Cooling Mode dB(A)	31
Heating Mode dB(A)	31
Simultaneous dB(A)	38
Changeover Cooling to Heating	33
Changeover Heating to Cooling	38
Unit Net Weight (lbs.)	60
Unit Shipping Weight (lbs.)	75

**Features:**

- Allows connected indoor units to be in cooling or heating mode simultaneously.
- Internal components are insulated.
  - External casing insulation is not needed.<sup>4</sup>
  - Condensate drain not needed.
- Includes high pressure vapor pipe strainer accessory.
- Factory installed indoor unit vapor pipe strainers.
- Series or parallel connection with additional heat recovery units.
- Flexible placement for service access or pipe routing.
- Access panels:
  - Top panel for EEV heads.
  - Rear panel for control access.
  - Bottom panel for refrigerant circuit.

**Notes:**

1. Each port can allow up to 8 indoor units with a maximum capacity of 60 MBh per port.
2. Multiple units installed on the same heat recovery port must operate in the same mode. Auto-changeover or Mode override is not possible.
3. Power wiring is field provided, and must comply with the applicable local and national codes.
4. All refrigerant piping requires insulation.
5. Communication cable between Main outdoor units to indoor units / heat recovery units to be 18 AWG, 2-conductor, twisted, stranded, shielded. Ensure the communication cable shield is properly grounded to the Main outdoor unit chassis only. Ⓢ Do not ground the outdoor unit to indoor units / heat recovery units communication cable at any other point. Wiring must comply with all applicable local and national codes.
6. Kit components must be kept dry and free of debris before installation.
7. This unit comes with a dry nitrogen charge.
8. Must follow installation instructions in the applicable LG installation manual.



**PRHR063A**  
 Multi V™ Heat Recovery Unit  
 Six (6) Port



Tag No.: \_\_\_\_\_  
 Date: 7/24/2023  
 PO No.: \_\_\_\_\_

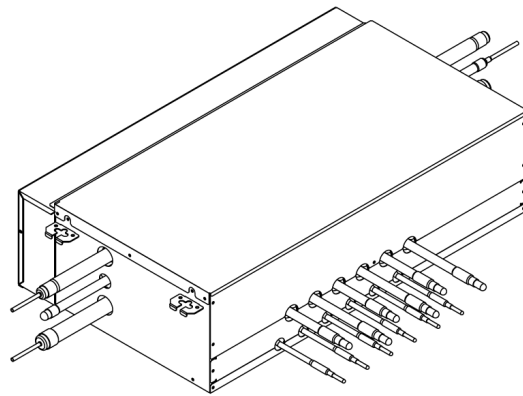
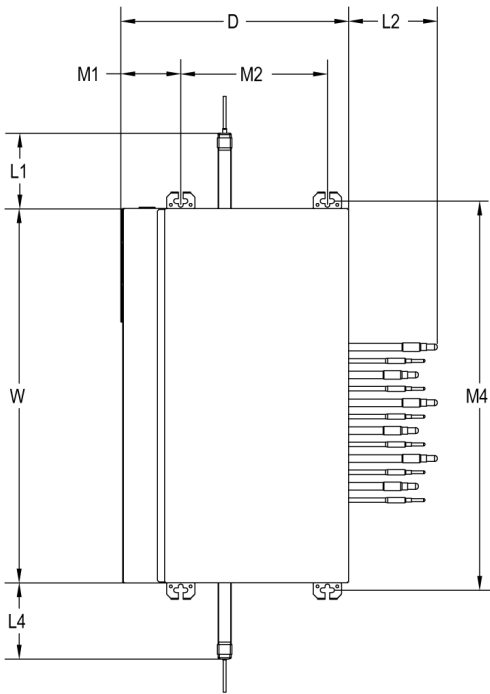

– Connect the strainer that is provided as an accessory to the HRU high pressure vapor pipe.  
 – Strainers are factory installed on the indoor unit vapor piping.

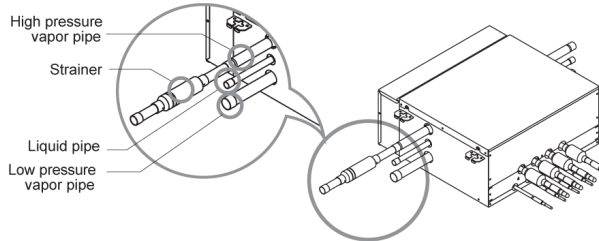

W	31-1/4"
H	8-5/8"
D	18-15/16"
L1	6-5/16"
L2	6-15/16"
L3	3/4"
L4	6-5/16"
L5	2-3/16"
L6	8-1/16"
L7	6-7/8"
L8	2-5/16"
L9	8-9/16"
L10	6-3/16"
L11	3-9/16"
L12	2"
M1	4-15/16"
M2	12-1/4"
M3	1-1/2"
M4	32-1/2"

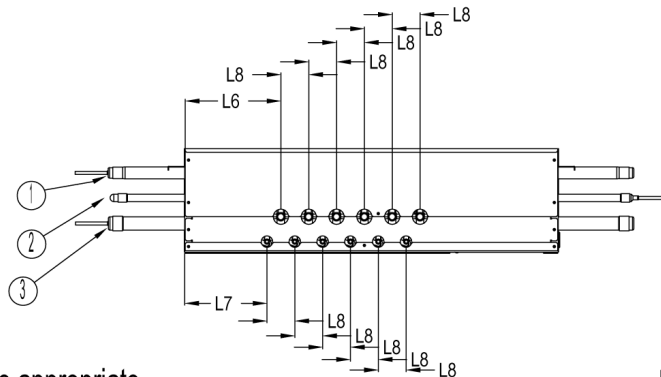
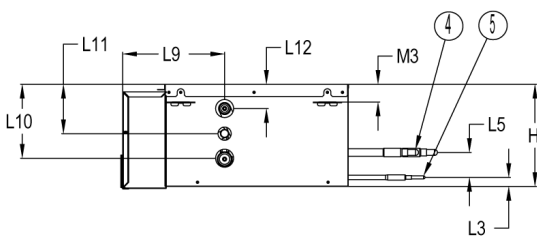

[Unit: inch]

**Note:**

1. Unit should be installed in compliance with the appropriate LG installation manual.
2. Unit should be grounded in accordance with the local regulations or applicable national codes.
3. All electrical components and materials supplied from the site must comply with the local regulations or national codes.

6	Control box
5	Liquid pipe to Indoor unit
4	Vapor pipe to Indoor unit
3	Low pressure vapor pipe
2	Liquid pipe to Outdoor unit
1	High pressure vapor pipe
No.	Part Name

**Date:** 7/24/2023

**For:**  File  Resubmit  
 Approval  Other\_\_\_\_\_

**PO No.:**

**Architect:** Lewis Architects and Engineers

**GC:** TBD

**Engr:** Lewis Architects and Engineers

**Mech:** Comfort Systems USA

**Rep:** Airetech Corporation  
 (Company)

Nick Moore  
 (Project Manager)



**PRHR083A**  
**Multi V™ Heat Recovery Unit**  
 Eight (8) Port

**Performance:**

Maximum Port Capacity Btu/h (each port) <sup>1,2</sup>	60,000
Maximum Unit Capacity Btu/h (sum of ports)	230,000
Number of Indoor Unit Ports	8
Max. Connectible Number of Indoor Units	64
Max. Connectible Number of Indoor Units per Branch	8
Power Input <sup>3</sup>	
Cooling	75.9
Heating	72.1

**Electrical:<sup>3</sup>**

Power Supply (V/Hz/Ø)	208-230/60/1
Rated Amps	0.09

**Refrigerant Piping:<sup>4</sup>**

Port Liquid Line (in., O.D.)	3/8
Port Vapor Line (in., O.D.)	5/8
System Liquid Line (in., O.D.)	5/8
System Vapor Line High (in., O.D.)	7/8
System Vapor Line Low (in., O.D.)	1-1/8

**Unit Data:**

Refrigerant Type	R410A
Refrigerant Control	EEV
Sound Pressure	
Cooling Mode dB(A)	31
Heating Mode dB(A)	31
Simultaneous dB(A)	38
Changeover Cooling to Heating	33
Changeover Heating to Cooling	38
Unit Net Weight (lbs.)	68
Unit Shipping Weight (lbs.)	82

**Features:**

- Allows connected indoor units to be in cooling or heating mode simultaneously.
- Internal components are insulated.
  - External casing insulation is not needed.<sup>4</sup>
  - Condensate drain not needed.
- Includes high pressure vapor pipe strainer accessory.
- Factory installed indoor unit vapor pipe strainers.
- Series or parallel connection with additional heat recovery units.
- Flexible placement for service access or pipe routing.
- Access panels:
  - Top panel for EEV heads.
  - Rear panel for control access.
  - Bottom panel for refrigerant circuit.

**Notes:**

1. Each port can allow up to 8 indoor units with a maximum capacity of 60 MBh per port.
2. Multiple units installed on the same heat recovery port must operate in the same mode. Auto-changeover or Mode override is not possible.
3. Power wiring is field provided, and must comply with the applicable local and national codes.
4. All refrigerant piping requires insulation.
5. Communication cable between Main outdoor units to indoor units / heat recovery units to be 18 AWG, 2-conductor, twisted, stranded, shielded. Ensure the communication cable shield is properly grounded to the Main outdoor unit chassis only. Ⓞ Do not ground the outdoor unit to indoor units / heat recovery units communication cable at any other point. Wiring must comply with all applicable local and national codes.
6. Kit components must be kept dry and free of debris before installation.
7. This unit comes with a dry nitrogen charge.
8. Must follow installation instructions in the applicable LG installation manual.



**PRHR083A**  
Multi V™ Heat Recovery Unit  
Eight (8) Port



Tag No.: \_\_\_\_\_

Date: 7/24/2023

PO No.: \_\_\_\_\_

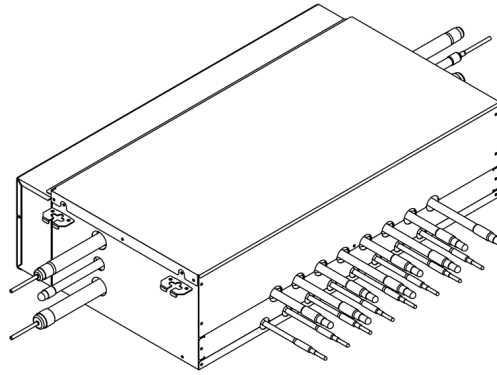
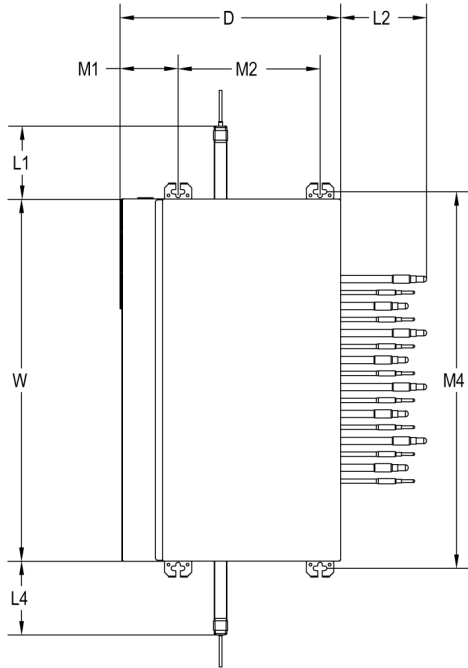

- Connect the strainer that is provided as an accessory to the HRU high pressure vapor pipe.
- Strainers are factory installed on the indoor unit vapor piping.

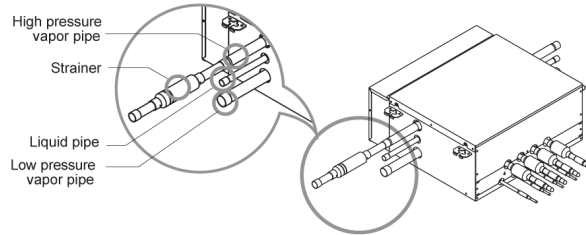

W	31-1/4"
H	8-5/8"
D	18-15/16"
L1	6-5/16"
L2	6-15/16"
L3	3/4"
L4	6-5/16"
L5	2-3/16"
L6	8-1/16"
L7	6-7/8"
L8	2-5/16"
L9	8-9/16"
L10	6-3/16"
L11	3-9/16"
L12	2"
M1	4-15/16"
M2	12-1/4"
M3	1-1/2"
M4	32-1/2"

[Unit: inch]

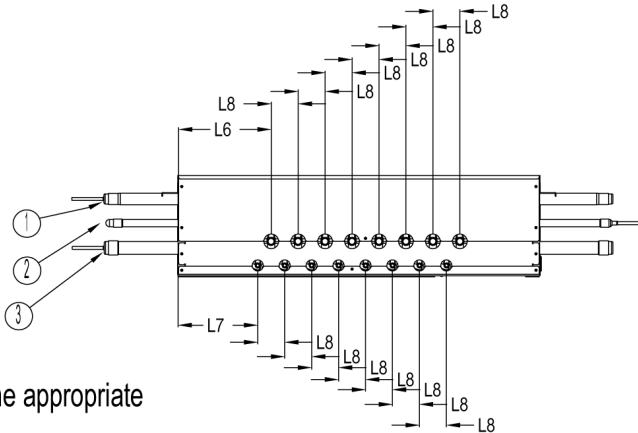
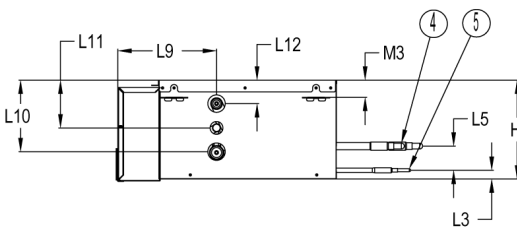

**Note:**

1. Unit should be installed in compliance with the appropriate LG installation manual.
2. Unit should be grounded in accordance with the local regulations or applicable national codes.
3. All electrical components and materials supplied from the site must comply with the local regulations or national codes.

6	Control box
5	Liquid pipe to Indoor unit
4	Vapor pipe to Indoor unit
3	Low pressure vapor pipe
2	Liquid pipe to Outdoor unit
1	High pressure vapor pipe
No.	Part Name

Date: 7/24/2023

For:  File  Resubmit  
 Approval  Other

PO No.:

Architect: Lewis Architects and Engineers

GC: TBD

Engr: Lewis Architects and Engineers

Mech: Comfort Systems USA

Rep: Airetech Corporation  
 (Company)

Nick Moore  
 (Project Manager)

**PACS5A000**  
**AC Smart 5 Controller**  
 Central Control/Integration Solutions

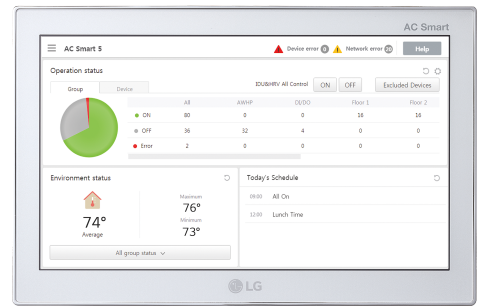

**Electrical:**

Power Consumption	22 VA
Power Supply	24 VAC 60 Hz

40 VA transformer recommended.

**Surrounding Conditions:**

Operating Temperature	32 to 104°F
Storage Temperature	-4 to 140°F
Humidity	0-98% (non-condensing)

**Unit Data:**

Dimensions	10"W x 6-5/8"H x 1-3/16"D
Maximum Number of Devices	128
Maximum Number of ODU's	16 per V-net
Maximum Number of Controllers	2 per V-net

**Standard Features:**

- Configurable Home Screen
- HTML5 supported Graphical User Interface
- Removable micro-SD card with 8GB flash total storage for data backup
- Exportable Trending Logs for Temperature, Event and Operation
- 10 inch class (1024 x 600) TFT LCD Touch Screen
- Indoor Unit Control/Monitoring by Groups/Indoor Units
- Two Digital Input and two Digital Outputs for Device Interlocking

**Basic Unit Function:**

- Multiple Language Selections
- Operation – On/Off
- Mode – Auto/Cool/Dry/Heat/Fan Only
- Setpoint
- Fan Speed – Auto/Low/Med/High
- Louver Swing

**Advanced Unit Function:**

- Two Setpoint Auto-changeover
- Two Setpoint Setback
- 200 Programmable Schedule Events with control of Setpoint, On/Off, Mode, Fan Speed, Controller Lock, and Louver Swing
- Temperature Setpoint Range Limit
- Remote Controller Lock (All, Setpoint, Mode, Fan Speed)
- Run Time Limit (Unoccupied Override)
- Software Device Interlocking
- Manual Control and Scheduling of IO Module
- Peak/Demand Control
- Visual Floor plan Navigation
- Error E-mail Notification
- Power Distribution Indicator (PDI) (optional)
- Energy Reporting with appropriate accessories

**Notes:**

Must follow installation instructions in the applicable LG installation manual. Available functions/features may differ based on the connected system.

For a complete list of available accessories, contact your LG representative.

For continual product development, LG reserves the right to change specifications without notice.

© LG Electronics U.S.A., Inc., Englewood Cliffs, NJ. All rights reserved. "LG Life's Good" is a registered trademark of LG Corp. /www.lghvac.com

**Supported Network Protocols:**

BACnet TCP/IP
Modbus TCP

**Connectivity:**

LG Communications	2 Channel/RS-485 V-Net*
Ethernet	10/100 BASE-T

\*Channel 1 is configurable for RS-485 or V-Net.  
 Channel 2 is for V-Net communication only.

**Communications Cabling Specifications (V-Net):**

Type	2-conductor, stranded, twisted, shielded copper cable/PVC or vinyl jacket
Size	AWG 18 x 2
Maximum Length	3,280 ft (end to end)

AWG - American Wire Gauge

**Optional Accessories:**

- PI-485 V-Net Interface Adapter for DFS - PMNFP14A0
- PI-485 V-Net Interface Adapter for ERV - PSNFP14A0
- I/O Module - PEXPMB000
- Power Distribution Indicator (PDI) - PQNUD1S41

**Dimensions:**

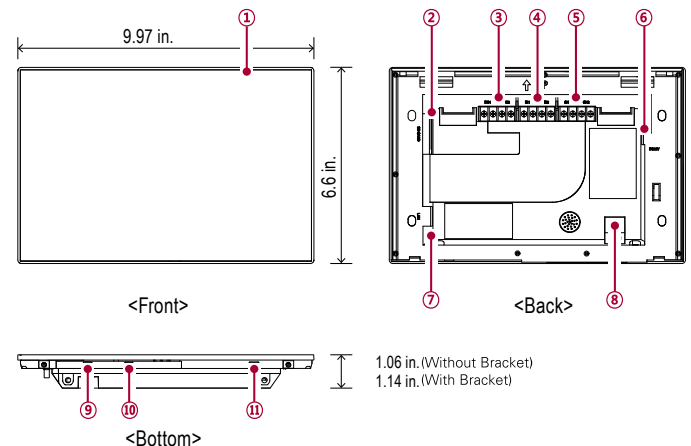

- |                    |                   |
|--------------------|-------------------|
| 1. Touch Screen    | 7. Ethernet Port  |
| 2. SD Card Slot    | 8. 24 VAC Input   |
| 3. Digital Outputs | 9. Micro USB Port |
| 4. Digital Inputs  | 10. Mini USB Port |
| 5. V-Net Ports     | 11. Power Button  |
| 6. 12 VDC Input    |                   |



BACnet® is a registered trademark of ASHRAE.

SB\_AC\_Smart5\_PACS5A000\_2020\_07\_17\_094520

**PACS5A000****AC Smart 5 Controller**

Central Control/Integration Solutions



Tag No.: \_\_\_\_\_

Date: 7/24/2023

PO No.: \_\_\_\_\_

**IDU Points**

Name	Object Name (XXX : Unit Address Number)	Object Type
On/Off (Setting)	StartStopCommand_XXX	BO
On/Off (Status)	StartStopStatus_XXX	BI
Lock (Setting)	LockCommand_XXX	BO
Lock (Status)	LockStatus_XXX	BI
Filter Sign	FilterSign_XXX	BI
Filter Sign reset	FilterSignReset_XXX	BV
Operation Mode (Setting)	AirConModeCommand_XXX	MO
Operation Mode (Status)	AirConModeStatus_XXX	MI
Swing (Setting)	SwingCommand_XXX	BO
Swing (Status)	SwingStatus_XXX	BI
Fan Speed (Setting)	FanSpeedCommand_XXX	MO
Fan Speed (Status)	FanSpeedStatus_XXX	MI
Set Room Temperature	SetRoomTemp_XXX	AV
Room Temperature	RoomTemp_XXX	AI
Alarm	Alarm_XXX	BI
Error Code	MalfunctionCode_XXX	AI
Set Temperature (Status)	SetTempStatus_XXX	AI
Accumulated Power Distribution (Status)	Accumulated power(100 Watt)_XXX	AI
Set Upper Temperature (Setting)	TempRangeUpperLimitCommand_XXX	AV
Set Lower Temperature (Setting)	TempRangeLowerLimitCommand_XXX	AV
Set Upper Temperature (Status)	TempRangeUpperLimitStatus_XXX	AI
Set Lower Temperature (Status)	TempRangeLowerLimitStatus_XXX	AI
Mode Lock (Setting)	ModeLockCommand_XXX	BO
Mode Lock (Status)	ModeLockStatus_XXX	BI
Fan Lock (Setting)	FanLockCommand_XXX	BO
Fan Lock (Status)	FanLockStatus_XXX	BI

**PACS5A000****AC Smart 5 Controller**

Central Control/Integration Solutions



Tag No.: \_\_\_\_\_

Date: 7/24/2023

PO No.: \_\_\_\_\_

**IDU Points, continued.**

Name	Object Name (XXX : Unit Address Number)	Object Type
Occupancy (Setting)	OccupancyCommand_XXX	BO
Occupancy (Status)	OccupancyStatus_XXX	BI
2Set Cooling Set Temperature (Setting)	2SetCoolingTempCommand_XXX	AV
2Set Cooling Set Temperature (Status)	2SetCoolingTempStatus_XXX	AI
2Set Heating Set Temperature (Setting)	2SetHeatingTempCommand_XXX	AV
2Set Heating Set Temperature (Status)	2SetHeatingTempStatus_XXX	AI
2Set Cooling Upper Temperature (Setting)	2SetCoolingUpperLimitCommand_XXX	AV
2Set Cooling Upper Temperature (Status)	2SetCoolingUpperLimitStatus_XXX	AI
2Set Heating Upper Temperature (Setting)	2SetHeatingUpperLimitCommand_XXX	AV
2Set Heating Upper Temperature (Status)	2SetHeatingUpperLimitStatus_XXX	AI
2Set Cooling Lower Temperature (Setting)	2SetCoolingLowerLimitCommand_XXX	AV
2Set Heating Lower Temperature (Setting)	2SetHeatingLowerLimitCommand_XXX	AV
2Set Heating Lower Temperature (Status)	2SetHeatingLowerLimitStatus_XXX	AI
Thermo Status (Status)	ThermoStatus_XXX	BI
Accumulated Gas Distribution (Status)	AccumulatedGas(100 Watt)_XXX	AI
Dust Sensor Available (Status)	DustSensorAvail_XXX	BI
Air Cleaning Operation (Setting)	AirCleaningOperCommand_XXX	BO
Air Cleaning Operation (Status)	AirCleaningOperStatus_XXX	BI
Fine Dust (Status)	FineDustStatus_XXX	AI
Ultra Fine Dust (Status)	UltraFineDustStatus_XXX	AI
Super Ultra Fine Dust (Status)	SuperUltraFineDustStatus_XXX	AI
Humidity (Status)	HumidityStatus_XXX	AI
Comfort Cooling Available (Status)	ComfortCoolingAvail_XXX	BI
Comfort Cooling Operation (Setting)	ComfortCoolingOperCommand_XXX	BO
Comfort Cooling Operation (Status)	ComfortCoolingOperStatus_XXX	BI
Comfort Cooling Step (Setting)	ComfortCoolingStepCommand_XXX	AV
Comfort Cooling Step (Status)	ComfortCoolingStepStatus_XXX	AI
Human Detection Available (Status)	HumanDetectionAvail_XXX	BI
Human Detection Operation (Setting)	HumanDetectionOperCommand_XXX	MO
Human Detection Operation (Status)	HumanDetectionOperStatus_XXX	MI
Human Detection Wind (Setting)	HumanDetectionWindCommand_XXX	MO
Human Detection Wind (Status)	HumanDetectionWindStatus_XXX	MI
Human Detection Time (Setting)	HumanDetectionTimeCommand_XXX	MO
Human Detection Time (Status)	HumanDetectionTimeStatus_XXX	MI

**PACS5A000****AC Smart 5 Controller**

Central Control/Integration Solutions



Tag No.: \_\_\_\_\_

Date: 7/24/2023

PO No.: \_\_\_\_\_

**Vent Points**

Name	Object Name (XXX : Unit Address Number)	Object Type
On/Off (Setting)	StartStopCommand_XXX	BO
On/Off (Status)	StartStopStatus_XXX	BI
Lock (Setting)	LockCommand_XXX	BO
Lock (Status)	LockStatus_XXX	BI
Filter Sign	FilterSign_XXX	BI
Filter Sign reset	FilterSignReset_XXX	BV
Operation Mode (Setting)	AirConModeCommand_XXX	MO
Operation Mode (Status)	AirConModeStatus_XXX	MI
Fan Speed (Setting)	FanSpeedCommand_XXX	MO
Fan Speed (Status)	FanSpeedStatus_XXX	MI
Set Room Temperature	SetRoomTemp_XXX	AV
Alarm	Alarm_XXX	BI
Error Code	MalfunctionCode_XXX	AI
User Mode (Setting)	UserModeCommand_XXX	MO
User Mode (Status)	UserModeStatus_XXX	MI
Set Temperature (Status)	SetTempStatus_XXX	AI
Accumulated Power Distribution (Status)	Accumulated power(100 Watt)_XXX	AI
AC Operation Mode (Setting)	UserModeAcCommand_XXX	MO
AC Operation Mode (Status)	UserModeAcStatus_XXX	MI
AC ON/OFF (Setting)	UserModeAcOperCommand_XXX	BO
AC ON/OFF (Status)	UserModeAcOperStatus_XXX	BI
AC Humidify (Setting)	HumidifierOperCommand_XXX	BO
AC Humidify (Status)	HumidifierOperStatus_XXX	BI
Partial Lock Available (Status)	PatialLockAvail_XXX	BI
Set Upper Temperature (Setting)	TempRangeUpperLimitCommand_XXX	AV
Set Lower Temperature (Setting)	TempRangeLowerLimitCommand_XXX	AV
Set Upper Tempaerature (Status)	TempRangeUpperLimitStatus_XXX	AI
Set Lower Temperature (Status)	TempRangeLowerLimitStatus_XXX	AI
Mode Lock (Setting)	ModeLockCommand_XXX	BO
Mode Lock (Status)	ModeLockStatus_XXX	BI
Fan Lock (Setting)	FanLockCommand_XXX	BO
Fan Lock (Status)	FanLockStatus_XXX	BI
NTFC Available (Status)	NtfcAvail_XXX	BI
NTFC Operation (Setting)	NtfcOperCommand_XXX	BO
NTFC Operation (Status)	NtfcOperStatus_XXX	BI
NTFC Lock (Setting)	NtfcLockCommand_XXX	BO
NTFC Lock (Status)	NtfcLockStatus_XXX	BI

**PACS5A000****AC Smart 5 Controller**

Central Control/Integration Solutions



Tag No.: \_\_\_\_\_

Date: 7/24/2023

PO No.: \_\_\_\_\_

**AHU Points**

Name	Object Name (XXX : Unit Address Number)	Object Type
On/Off (Setting)	StartStopCommand_XXX	BO
On/Off (Status)	StartStopStatus_XXX	BI
Lock (Setting)	LockCommand_XXX	BO
Lock (Status)	LockStatus_XXX	BI
Filter Sign	FilterSign_XXX	BI
Operation Mode (Setting)	AirConModeCommand_XXX	MO
Operation Mode (Status)	AirConModeStatus_XXX	MI
Fan Speed (Setting)	FanSpeedCommand_XXX	MO
Fan Speed (Status)	FanSpeedStatus_XXX	MI
Set Room Temperature	SetRoomTemp_XXX	AV
Room Temperature	RoomTemp_XXX	AI
Alarm	Alarm_XXX	BI
Error Code	MalfunctionCode_XXX	AI
Set Temperature (Status)	SetTempStatus_XXX	AI
FireAlarm (Setting)	FireAlarmCommand_XXX	BO
FireAlarm (Status)	FireAlarmStatus_XXX	BI
Humidity (Setting)	SetHumidityCommand_XXX	AV
Humidity (Status)	SetHumidityStatus_XXX	AI
Humidify ON/OFF (Setting)	HumidifyCommand_XXX	BO
Humidify ON/OFF (Status)	HumidifyStatus_XXX	BI
Auto Ventilation ON/OFF (Setting)	AutoVentilCommand_XXX	BO
Auto Ventilation ON/OFF (Status)	AutoVentilStatus_XXX	BI
Supply Unit Temperature (Status)	SupplyTempStatus_XXX	AI
Outdoor Unit Temperature (Status)	OutdoorTempStatus_XXX	AI
Mix Unit Temperature (Status)	MixTempStatus_XXX	AI
Supply Unit Humidity (Status)	SupplyHumidifyStatus_XXX	AI
Outdoor Unit Humidity (Status)	OutdoorHumidifyStatus_XXX	AI
Ventilation Unit Humidity (Status)	VentilHumidifyStatus_XXX	AI
CO2 Value (Status)	CO2ValueStatus_XXX	AI
Humidity Unit ON/OFF (Status)	HumidifyUnitStatus_XXX	BI
Heating Unit ON/OFF (Status)	HeaterUnitStatus_XXX	BI
Ventilator FAN ON/OFF (Status)	VentilFanStatus_XXX	BI
Supply Unit FAN ON/OFF (Status)	SupplyFanStatus_XXX	BI
Current OA Damper (Status)	CurrOADamperStatus_XXX	AI
Current EA Damper (Status)	CurrEADamperStatus_XXX	AI

**PACS5A000**  
**AC Smart 5 Controller**  
 Central Control/Integration Solutions



Tag No.: \_\_\_\_\_  
 Date: 7/24/2023  
 PO No.: \_\_\_\_\_

**AHU Points, continued.**

Name	Object Name (XXX : Unit Address Number)	Object Type
Current Mix Damper (Status)	CurrMixDamperStatus_XXX	AI
Cooling OA Damper (Setting)	OADamperCoolCommand_XXX	AV
Cooling OA Damper (Status))	OADamperCoolStatus_XXX	AI
Cooling EA Damper (Setting)	EADamperCoolCommand_XXX	AV
Cooling EA Damper (Status))	EADamperCoolStatus_XXX	AI
Cooling Mix Damper (Setting)	MixDamperCoolCommand_XXX	AV
Cooling Mix Damper (Status))	MixDamperCoolStatus_XXX	AI
Heating OA Damper (Setting)	OADamperHeatCommand_XXX	AV
Heating OA Damper (Status))	OADamperHeatStatus_XXX	AI
Heating EA Damper (Setting)	EADamperHeatCommand_XXX	AV
Heating EA Damper (Status))	EADamperHeatStatus_XXX	AI
Heating Mix Damper (Setting)	MixDamperHeatCommand_XXX	AV
Heating Mix Damper (Status))	MixDamperHeatStatus_XXX	AI
FAN OA Damper (Setting)	OADamperFanCommand_XXX	AV
FAN OA Damper (Status))	OADamperFanStatus_XXX	AI
FAN EA Damper (Setting)	EADamperFanCommand_XXX	AV
FAN EA Damper (Status))	EADamperFanStatus_XXX	AI
FAN Mix Damper (Setting)	MixDamperFanCommand_XXX	AV
FAN Mix Damper (Status))	MixDamperFanStatus_XXX	AI

**PACS5A000****AC Smart 5 Controller**

Central Control/Integration Solutions



Tag No.:

Date: 7/24/2023

PO No.:

**AWHP Points**

Name	Object Name (XXX : Unit Address Number)	Object Type
Run/Stop (Setting)	StartStopCommand_XXX	BO
Run/Stop (Status)	StartStopStatus_XXX	BI
Lock (Setting)	LockCommand_XXX	BO
Lock (Status)	LockStatus_XXX	BI
Operation Mode (Setting)	ModeCommand_XXX	MO
Operation Mode (Status)	ModeStatus_XXX	MI
Set Room Temperature (Setting)	SetRoomTempCommand_XXX	AV
Set Room Temperature (Status)	SetRoomTempStatus_XXX	AI
Set Hot Water Temperature (Setting)	SetHotWaterTempCommand_XXX	AV
Set Hot Water Temperature (Status)	SetHotWaterTempStatus_XXX	AI
Set PipeOut Water Temperature (Setting)	SetPipeOutWaterTempCommand_XXX	AV
Set PipeOut Water Temperature (Status)	SetPipeOutWaterTempStatus_XXX	AI
Setting Temperature Reference (Air/Water)	AirWaterFlag_XXX	BI
Hot Water Only Mode	HotWaterOnlyFlag_XXX	BI
Current Room Temperature	RoomTemp_XXX	AI
Alarm Event	Alarm_XXX	BI
Malfunction Code	MalfunctionCode_XXX	AI
HotWater On/Off (Setting)	HotWaterCommand_XXX	BO
HotWater On/Off (Status)	HotWaterStatus_XXX	BI
Pipe Inlet Temperature Status	PipeInTempStatus_XXX	AI
Water Tank Temperature Status	TankTempStatus_XXX	AI
Solar Temperature Status	SolarTempStatus_XXX	AI
Pipe Outlet Temperature Status	PipeOutTempStatus_XXX	AI
Accumulated Power Distribution (Status)	Accumulated power(100 Watt)_XXX	AI

**PACS5A000**  
**AC Smart 5 Controller**  
 Central Control/Integration Solutions



Tag No.: \_\_\_\_\_

Date: 7/24/2023

PO No.: \_\_\_\_\_

**General Points**

Name	Object Name (XXX : Unit Address Number)	Object Type
All Unit Run/Stop (Setting)	AllStartStopCommand	BO
All Unit Set Room Temperature (Setting)	AllSetRoomTempCommand	AV
All Unit Temperature Lock (Setting)	AllTempLockCommand	BO
Total Accumulated Power (Status)	TotalAccumulatedPower	AI
Peak Control Operation (Setting)	PeakStartStopCommand	BO
Peak Control Operation (Status)	PeakStartStopStatus	BI
Peak Shift Time(Setting)	PeakShiftTimeCommand	AV
Peak Shift Time(Status)	PeakShiftTimeStatus	AI
Peak Target Ratio(Setting)	PeakTargetCommand	AV
Peak Target Ratio(Status)	PeakTargetStatus	AI
Peak Current Running Ratio(Status)	PeakCurrentStatus	AI
Remote Shutdown(Setting)	RemoteShutDownCommand	BO
Temperature Unit Setting (Setting)	TempUnitCommand	BO
Temperature Unit Setting (Status)	TempUnitStatus	BI

**PACS5A000****AC Smart 5 Controller**

Central Control/Integration Solutions



Tag No.:

Date: 7/24/2023

PO No.:

**ODU Points**

Name	Object Name (XXX : Unit Address Number)	Object Type
Compressor Operation	CompressorOperation_XXX	BI
Refrigerant Type	RefrigerantType_XXX	MI
Fan1 Frequency	Fan1Frequency_XXX	AI
High Pressure	HighPressure_XXX	AI
Low Pressure	LowPressure_XXX	AI
Compressor Suction Temp	CompressorSuctionTemp_XXX	AI
Liquid Pipe Temp	LiquidPipeTemp_XXX	AI
Heat Exchange Temp	HeatExchangeTemp_XXX	AI
Outdoor Unit EEV	OutdoorUnitEEV_XXX	AI
Over-cooler EEV	Over-coolerEEV_XXX	AI
Hot Gas Valve	HotGasValue_XXX	BI
Inverter Discharge Temp	InverterDischargeTemp_XXX	AI
Air Temperature	AirTemp_XXX	AI
Operation Mode	OperationMode_XXX	MI
Error Code	ErrorCode_XXX	AI
Inverter1 Compressor Frequency	Inverter1CompressorFrequency_XXX	AI
Inverter2 Compressor Frequency	Inverter2CompressorFrequency_XXX	AI
Fan2 Frequency	Fan2Frequency_XXX	AI
Inverter2 Discharge Temp	Inverter2DischargeTemp_XXX	AI
Std1 Discharge Temp	Std1DischargeTemp_XXX	AI
Std2 Discharge Temp	Std2DischargeTemp_XXX	AI
Upper Hex Temp	UpperHexTemp_XXX	AI
Lower Hex Temp	LowerHexTemp_XXX	AI
Sub Cool Pipe In Temp	SubCoolPipeInTemp_XXX	AI
Sub Cool Pipe Out Temp	SubCoolPipeOutTemp_XXX	AI
Sub EEV Pulse	SubEevPulse_XXX	AI
Oil Equalizing EEV	OilEqualizingEEV_XXX	AI
Vapor Injection EEV1	ViEev1_XXX	AI
Vapor Injection EEV2	ViEev2_XXX	AI
Inverter1 Heater	Inverter1Heater_XXX	BI
Inverter2 Heater	Inverter2Heater_XXX	BI
Inverter1 Oil Sensor	Inverter1OilSensor_XXX	BI
Inverter2 Oil Sensor	Inverter2OilSensor_XXX	BI
Inverter1 Backup	Inverter1Backup_XXX	BI
Inverter2 Backup	Inverter2Backup_XXX	BI
DDC	DDC_XXX	BI

**PACS5A000****AC Smart 5 Controller**

Central Control/Integration Solutions



Tag No.:

Date: 7/24/2023

PO No.:

**ODU Points, continued.**

Name	Object Name (XXX : Unit Address Number)	Object Type
(Slave1) Compressor Operation	CompressorOperation_XXX	BI
(Slave1) Refrigerant Type	RefrigerantType_XXX	MI
(Slave1) Fan1 Frequency	Fan1Frequency_XXX	AI
(Slave1) High Pressure	HighPressure_XXX	AI
(Slave1) Low Pressure	LowPressure_XXX	AI
(Slave1) Compressor Suction Temp	CompressorSuctionTemp_XXX	AI
(Slave1) Liquid Pipe Temp	LiquidPipeTemp_XXX	AI
(Slave1) Heat Exchange Temp	HeatExchangeTemp_XXX	AI
(Slave1) Outdoor Unit EEV	OutdoorUnitEEV_XXX	AI
(Slave1) Over-cooler EEV	Over-coolerEEV_XXX	AI
(Slave1) Hot Gas Valve	HotGasValue_XXX	BI
(Slave1) Inverter Discharge Temp	InverterDischargeTemp_XXX	AI
(Slave1) Air Temperature	AirTemp_XXX	AI
(Slave1) Operation Mode	OperationMode_XXX	MI
(Slave1) Error Code	ErrorCode_XXX	AI
(Slave1) Inverter1 Compressor Frequency	Inverter1CompressorFrequency_XXX	AI
(Slave1) Inverter2 Compressor Frequency	Inverter2CompressorFrequency_XXX	AI
(Slave1) Fan2 Frequency	Fan2Frequency_XXX	AI
(Slave1) Inverter2 Discharge Temp	Inverter2DischargeTemp_XXX	AI
(Slave1) Std1 Discharge Temp	Std1DischargeTemp_XXX	AI
(Slave1) Std2 Discharge Temp	Std2DischargeTemp_XXX	AI
(Slave1) Upper Hex Temp	UpperHexTemp_XXX	AI
(Slave1) Lower Hex Temp	LowerHexTemp_XXX	AI
(Slave1) Sub Cool Pipe In Temp	SubCoolPipeInTemp_XXX	AI
(Slave1) Sub Cool Pipe Out Temp	SubCoolPipeOutTemp_XXX	AI
(Slave1) Sub EEV Pulse	SubEevPulse_XXX	AI
(Slave1) Oil Equalizing EEV	OilEqualizingEEV_XXX	AI
(Slave1) Vapor Injection EEV1	ViEev1_XXX	AI
(Slave1) Vapor Injection EEV2	ViEev2_XXX	AI
(Slave1) Inverter1 Heater	Inverter1Heater_XXX	BI
(Slave1) Inverter2 Heater	Inverter2Heater_XXX	BI
(Slave1) Inverter1 Oil Sensor	Inverter1OilSensor_XXX	BI
(Slave1) Inverter2 Oil Sensor	Inverter2OilSensor_XXX	BI
(Slave1) Inverter1 Backup	Inverter1Backup_XXX	BI
(Slave1) Inverter2 Backup	Inverter2Backup_XXX	BI
(Slave1) DDC	DDC_XXX	BI

**PACS5A000**

AC Smart 5 Controller

Central Control/Integration Solutions



Tag No.:

Date: 7/24/2023

PO No.:

**ODU Points, continued.**

Name	Object Name (XXX : Unit Address Number)	Object Type
(Slave2) Compressor Operation	CompressorOperation_XXX	BI
(Slave2) Refrigerant Type	RefrigerantType_XXX	MI
(Slave2) Fan1 Frequency	Fan1Frequency_XXX	AI
(Slave2) High Pressure	HighPressure_XXX	AI
(Slave2) Low Pressure	LowPressure_XXX	AI
(Slave2) Compressor Suction Temp	CompressorSuctionTemp_XXX	AI
(Slave2) Liquid Pipe Temp	LiquidPipeTemp_XXX	AI
(Slave2) Heat Exchange Temp	HeatExchangeTemp_XXX	AI
(Slave2) Outdoor Unit EEV	OutdoorUnitEEV_XXX	AI
(Slave2) Over-cooler EEV	Over-coolerEEV_XXX	AI
(Slave2) Hot Gas Valve	HotGasValue_XXX	BI
(Slave2) Inverter Discharge Temp	InverterDischargeTemp_XXX	AI
(Slave2) Air Temperature	AirTemp_XXX	AI
(Slave2) Operation Mode	OperationMode_XXX	MI
(Slave2) Error Code	ErrorCode_XXX	AI
(Slave2) Inverter1 Compressor Frequency	Inverter1CompressorFrequency_XXX	AI
(Slave2) Inverter2 Compressor Frequency	Inverter2CompressorFrequency_XXX	AI
(Slave2) Fan2 Frequency	Fan2Frequency_XXX	AI
(Slave2) Inverter2 Discharge Temp	Inverter2DischargeTemp_XXX	AI
(Slave2) Std1 Discharge Temp	Std1DischargeTemp_XXX	AI
(Slave2) Std2 Discharge Temp	Std2DischargeTemp_XXX	AI
(Slave2) Upper Hex Temp	UpperHexTemp_XXX	AI
(Slave2) Lower Hex Temp	LowerHexTemp_XXX	AI
(Slave2) Sub Cool Pipe In Temp	SubCoolPipeInTemp_XXX	AI
(Slave2) Sub Cool Pipe Out Temp	SubCoolPipeOutTemp_XXX	AI
(Slave2) Sub EEV Pulse	SubEevPulse_XXX	AI
(Slave2) Oil Equalizing EEV	OilEqualizingEEV_XXX	AI
(Slave2) Vapor Injection EEV1	ViEev1_XXX	AI
(Slave2) Vapor Injection EEV2	ViEev2_XXX	AI
(Slave2) Inverter1 Heater	Inverter1Heater_XXX	BI
(Slave2) Inverter2 Heater	Inverter2Heater_XXX	BI
(Slave2) Inverter1 Oil Sensor	Inverter1OilSensor_XXX	BI
(Slave2) Inverter2 Oil Sensor	Inverter2OilSensor_XXX	BI
(Slave2) Inverter1 Backup	Inverter1Backup_XXX	BI
(Slave2) Inverter2 Backup	Inverter2Backup_XXX	BI
(Slave2) DDC	DDC_XXX	BI

**PACS5A000**

AC Smart 5 Controller

Central Control/Integration Solutions



Tag No.: \_\_\_\_\_

Date: 7/24/2023

PO No.: \_\_\_\_\_

**ODU Points, continued.**

Name	Object Name (XXX : Unit Address Number)	Object Type
(Slave2) Compressor Operation	CompressorOperation_XXX	BI
(Slave2) Refrigerant Type	RefrigerantType_XXX	MI
(Slave2) Fan1 Frequency	Fan1Frequency_XXX	AI
(Slave2) High Pressure	HighPressure_XXX	AI
(Slave2) Low Pressure	LowPressure_XXX	AI
(Slave2) Compressor Suction Temp	CompressorSunctionTemp_XXX	AI
(Slave2) Liquid Pipe Temp	LiquidPipeTemp_XXX	AI
(Slave2) Heat Exchange Temp	HeatExchangeTemp_XXX	AI
(Slave2) Outdoor Unit EEV	OutdoorUnitEEV_XXX	AI
(Slave2) Over-cooler EEV	Over-coolerEEV_XXX	AI
(Slave2) Hot Gas Valve	HotGasValue_XXX	BI
(Slave2) Inverter Discharge Temp	InverterDischargeTemp_XXX	AI
(Slave2) Air Temperature	AirTemp_XXX	AI
(Slave2) Operation Mode	OperationMode_XXX	MI
(Slave2) Error Code	ErrorCode_XXX	AI
(Slave2) Inverter1 Compressor Frequency	Inverter1CompressorFrequency_XXX	AI
(Slave2) Inverter2 Compressor Frequency	Inverter2CompressorFrequency_XXX	AI
(Slave2) Fan2 Frequency	Fan2Frequency_XXX	AI
(Slave2) Inverter2 Discharge Temp	Inverter2DischargeTemp_XXX	AI
(Slave2) Std1 Discharge Temp	Std1DischargeTemp_XXX	AI
(Slave2) Std2 Discharge Temp	Std2DischargeTemp_XXX	AI
(Slave2) Upper Hex Temp	UpperHexTemp_XXX	AI
(Slave2) Lower Hex Temp	LowerHexTemp_XXX	AI
(Slave2) Sub Cool Pipe In Temp	SubCoolPipeInTemp_XXX	AI
(Slave2) Sub Cool Pipe Out Temp	SubCoolPipeOutTemp_XXX	AI
(Slave2) Sub EEV Pulse	SubEevPulse_XXX	AI
(Slave2) Oil Equalizing EEV	OilEqualizingEEV_XXX	AI
(Slave2) Vapor Injection EEV1	ViEev1_XXX	AI
(Slave2) Vapor Injection EEV2	ViEev2_XXX	AI
(Slave2) Inverter1 Heater	Inverter1Heater_XXX	BI
(Slave2) Inverter2 Heater	Inverter2Heater_XXX	BI
(Slave2) Inverter1 Oil Sensor	Inverter1OilSensor_XXX	BI
(Slave2) Inverter2 Oil Sensor	Inverter2OilSensor_XXX	BI
(Slave2) Inverter1 Backup	Inverter1Backup_XXX	BI
(Slave2) Inverter2 Backup	Inverter2Backup_XXX	BI
(Slave2) DDC	DDC_XXX	BI

Date: 7/24/2023	For: File	Resubmit
PO No.:	Approval	Other _____

Architect: Lewis Architects and Engineers GC: TBD

Engr: Lewis Architects and Engineers Mech: Comfort Systems USA

Rep: Airetech Corporation Nick Moore  
(Company) (Project Manager)

## Indoor Y-Branch Kits Multi V™ 3 Pipe



### Insulation<sup>1</sup> Properties:

Material	Polyolefin Foam
UL94 Flame Classification	HF-1

### Fitting Properties:

Material	Copper
Design Pressure	551 PSIG

Y-Branch Connection Diameters (in, ID)										
Model	Y-Branch Type	Port Identifier								
		1	2	3	4	5	6	7	8	9
ARBLB01621	Liquid	-	1/4	3/8	3/8	1/4	-	3/8	1/4	-
	Vapor Line Low	-	5/8	1/2	1/2	5/8	-	1/2	5/8	-
	Vapor Line High	3/8	5/8	1/2	1/2	5/8	3/8	1/2	5/8	3/8
ARBLB03321	Liquid	1/2	3/8	-	3/8	1/2	1/4	3/8	1/2	1/4
	Vapor Line Low	1	7/8	3/4	5/8	3/4	1/2	5/8	3/4	1/2
	Vapor Line High	3/4	1	7/8	7/8	3/4	5/8	7/8	3/4	5/8
ARBLB07121	Liquid	1/2	3/4	5/8	5/8	3/4	1/2	5/8	3/4	1/2
	Vapor Line Low	1-1/4	1-1/8	-	7/8	3/4	5/8	3/4	5/8	1/2
	Vapor Line High	1-1/8	1	-	7/8	1	3/4	7/8	1	3/4
ARBLB14521	Liquid	5/8	7/8	3/4	7/8	3/4	5/8	3/4	5/8	1/2
	Vapor Line Low	1-3/8	1-1/2	1-5/8	1-1/2	1-3/8	1-1/8	1-3/8	1-1/8	7/8
	Vapor Line High	1-1/8	1-3/8	1-1/4	1-1/8	1-1/4	1	1-1/8	1-1/4	1

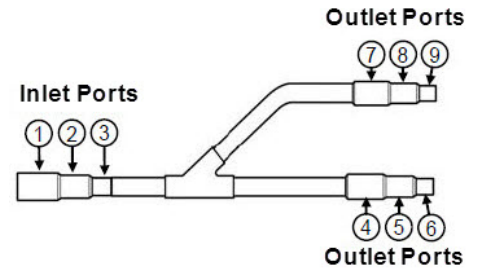

Not to scale

Reducer Diameters (in)						
Model	Qty/Kit	Reducer Type	10	11	12	Length
ARBLB01621	2	Liquid	1/2 ID	3/8 OD	-	2-3/4
		Vapor Line Low	3/4 ID	5/8 OD	-	2-3/4
		Vapor Line High	-	-	-	-
ARBLB03321	5	Liquid	-	-	-	-
			7/8 ID	3/4 OD	-	2-3/4
			1 ID	7/8 ID	3/4 OD	4-11/32
		Vapor Line Low	1-1/8 ID	1 OD	-	3-5/32
			5/8 OD	1/2 ID	-	2-3/4
Vapor Line High	5/8 OD	1/2 ID	3/8 ID	4-11/32		
	1/2 OD	3/8 ID	-	2-3/4		
ARBLB07121	8	Liquid	1/2 OD	3/8 ID	1/4 ID	4-11/32
			1-1/8 ID	7/8 ID	3/4 OD	4-23/32
			1-1/4 ID	1-1/8 ID	7/8 OD	4-23/32
		Vapor Line Low	1-3/8 ID	1-1/4 OD	-	3-17/32
			1/2 OD	3/8 ID	-	2-3/4
		Vapor Line High	3/4 OD	5/8 ID	-	2-3/4
			3/4 OD	5/8 ID	1/2 ID	4-11/32
ARBLB14521	12	Liquid	1/2 OD	3/8 ID	1/4 ID	4-11/32
			5/8 OD	1/2 ID	3/8 ID	4-11/32
			7/8 ID	3/4 OD	-	3-5/32
			5/8 OD	1/2 ID	-	2-3/4
			7/8 OD	3/4 ID	5/8 ID	4-23/32
			1-1/8 OD	7/8 ID	3/4 ID	4-23/32
		Vapor Line Low	1-5/8 ID	1-1/2 ID	1-3/8 OD	5-1/8
			1-5/8 ID	1-1/2 OD	-	3-17/32
			3/4 OD	5/8 ID	1/2 ID	4-11/32
		Vapor Line High	1/2 OD	3/8 ID	-	2-3/4
			1 OD	7/8 ID	-	3-5/32
			1 OD	7/8 ID	3/4 ID	4-23/32

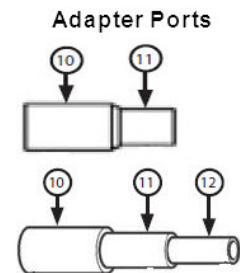

# Indoor Y-Branch Kits

## Multi V™ 3 Pipe



Tag #: \_\_\_\_\_

Date: 7/24/2023

PO No.: \_\_\_\_\_

Y-Branch Dimensions <sup>2</sup> (in)						
Model	Y-Branch Type	A	B	C	D	E
ARBLB01621	Liquid	2-29/32	6-9/16	8-1/32	11-1/16	11-1/2
	Vapor Line Low	2-29/32	4-1/2	7-31/32	11-1/16	11-1/2
	Vapor Line High	2-29/32	6-3/32	9-7/16	13-13/16	14-21/32
ARBLB03321	Liquid	2-29/32	4-1/2	8-1/32	12-5/8	13-1/16
	Vapor Line Low	3-9/32	6-29/32	10-7/8	15-11/32	16-1/4
	Vapor Line High	3-25/32	7-3/32	11-3/8	16-9/16	17-15/32
ARBLB07121	Liquid	3-9/32	6-1/8	10-1/32	14-9/32	15-1/2
	Vapor Line Low	3-25/32	5-1/2	10	14-13/16	15-29/32
	Vapor Line High	3-25/32	5-1/2	10-3/32	15	16-3/32
ARBLB14521	Liquid	3-25/32	7-3/32	11-11/16	16-3/8	17-15/32
	Vapor Line Low	4-29/32	7-7/8	13-23/32	18-17/32	20-11/32
	Vapor Line High	4-3/8	7-7/16	12-3/4	17-27/32	19-11/32

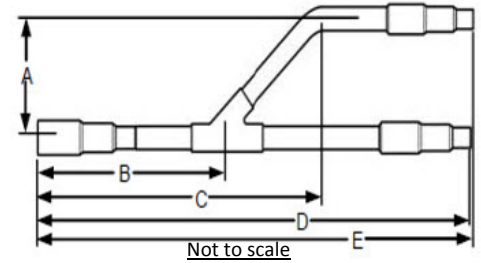

**Notes:**

1. Each Y-Branch kit comes with insulation for the following piping components - liquid, vapor line low and vapor line high.
2. LG branch fittings must be used. Field supplied branch fittings are not permitted.
3. Kit components must be kept dry and free of debris before installation.
4. Must follow installation instructions in the applicable LG installation manual.

Date: 7/24/2023	For: File	Resubmit
PO No.:	Approval	Other _____

Architect: Lewis Architects and Engineers GC: TBD

Engr: Lewis Architects and Engineers Mech: Comfort Systems USA

Rep: Airetech Corporation (Company) Nick Moore (Project Manager)

## Indoor Y-Branch Kits Multi V™ 3 Pipe



### Insulation<sup>1</sup> Properties:

Material	Polyolefin Foam
UL94 Flame Classification	HF-1

### Fitting Properties:

Material	Copper
Design Pressure	551 PSIG

Y-Branch Connection Diameters (in, ID)										
Model	Y-Branch Type	Port Identifier								
		1	2	3	4	5	6	7	8	9
ARBLB01621	Liquid	-	1/4	3/8	3/8	1/4	-	3/8	1/4	-
	Vapor Line Low	-	5/8	1/2	1/2	5/8	-	1/2	5/8	-
	Vapor Line High	3/8	5/8	1/2	1/2	5/8	3/8	1/2	5/8	3/8
ARBLB03321	Liquid	1/2	3/8	-	3/8	1/2	1/4	3/8	1/2	1/4
	Vapor Line Low	1	7/8	3/4	5/8	3/4	1/2	5/8	3/4	1/2
	Vapor Line High	3/4	1	7/8	7/8	3/4	5/8	7/8	3/4	5/8
ARBLB07121	Liquid	1/2	3/4	5/8	5/8	3/4	1/2	5/8	3/4	1/2
	Vapor Line Low	1-1/4	1-1/8	-	7/8	3/4	5/8	3/4	5/8	1/2
	Vapor Line High	1-1/8	1	-	7/8	1	3/4	7/8	1	3/4
ARBLB14521	Liquid	5/8	7/8	3/4	7/8	3/4	5/8	3/4	5/8	1/2
	Vapor Line Low	1-3/8	1-1/2	1-5/8	1-1/2	1-3/8	1-1/8	1-3/8	1-1/8	7/8
	Vapor Line High	1-1/8	1-3/8	1-1/4	1-1/8	1-1/4	1	1-1/8	1-1/4	1

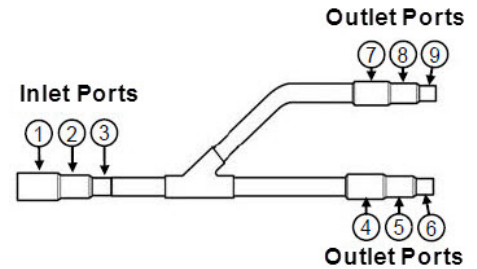

Reducer Diameters (in)						
Model	Qty/Kit	Reducer Type	10	11	12	Length
ARBLB01621	2	Liquid	1/2 ID	3/8 OD	-	2-3/4
		Vapor Line Low	3/4 ID	5/8 OD	-	2-3/4
		Vapor Line High	-	-	-	-
ARBLB03321	5	Liquid	-	-	-	-
		Vapor Line Low	7/8 ID	3/4 OD	-	2-3/4
			1 ID	7/8 ID	3/4 OD	4-11/32
			1-1/8 ID	1 OD	-	3-5/32
		Vapor Line High	5/8 OD	1/2 ID	-	2-3/4
5/8 OD	1/2 ID		3/8 ID	4-11/32		
ARBLB07121	8	Liquid	1/2 OD	3/8 ID	-	2-3/4
		Vapor Line Low	1-1/8 ID	7/8 ID	3/4 OD	4-23/32
			1-1/4 ID	1-1/8 ID	7/8 OD	4-23/32
			1-3/8 ID	1-1/4 OD	-	3-17/32
		Vapor Line High	1/2 OD	3/8 ID	-	2-3/4
			3/4 OD	5/8 ID	-	2-3/4
			3/4 OD	5/8 ID	1/2 ID	4-11/32
1/2 OD	3/8 ID		1/4 ID	4-11/32		
ARBLB14521	12	Liquid	5/8 OD	1/2 ID	3/8 ID	4-11/32
		Vapor Line Low	7/8 ID	3/4 OD	-	3-5/32
			5/8 OD	1/2 ID	-	2-3/4
			7/8 OD	3/4 ID	5/8 ID	4-23/32
			1-1/8 OD	7/8 ID	3/4 ID	4-23/32
			1-5/8 ID	1-1/2 ID	1-3/8 OD	5-1/8
			1-5/8 ID	1-1/2 OD	-	3-17/32
		Vapor Line High	3/4 OD	5/8 ID	1/2 ID	4-11/32
			1/2 OD	3/8 ID	-	2-3/4
			1 OD	7/8 ID	-	3-5/32
			1 OD	7/8 ID	3/4 ID	4-23/32

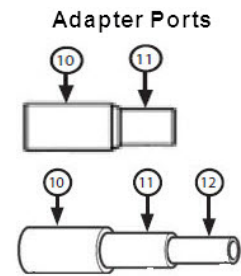

# Indoor Y-Branch Kits

## Multi V™ 3 Pipe



Tag #: \_\_\_\_\_

Date: 7/24/2023

PO No.: \_\_\_\_\_

Y-Branch Dimensions <sup>2</sup> (in)						
Model	Y-Branch Type	A	B	C	D	E
ARBLB01621	Liquid	2-29/32	6-9/16	8-1/32	11-1/16	11-1/2
	Vapor Line Low	2-29/32	4-1/2	7-31/32	11-1/16	11-1/2
	Vapor Line High	2-29/32	6-3/32	9-7/16	13-13/16	14-21/32
ARBLB03321	Liquid	2-29/32	4-1/2	8-1/32	12-5/8	13-1/16
	Vapor Line Low	3-9/32	6-29/32	10-7/8	15-11/32	16-1/4
	Vapor Line High	3-25/32	7-3/32	11-3/8	16-9/16	17-15/32
ARBLB07121	Liquid	3-9/32	6-1/8	10-1/32	14-9/32	15-1/2
	Vapor Line Low	3-25/32	5-1/2	10	14-13/16	15-29/32
	Vapor Line High	3-25/32	5-1/2	10-3/32	15	16-3/32
ARBLB14521	Liquid	3-25/32	7-3/32	11-11/16	16-3/8	17-15/32
	Vapor Line Low	4-29/32	7-7/8	13-23/32	18-17/32	20-11/32
	Vapor Line High	4-3/8	7-7/16	12-3/4	17-27/32	19-11/32

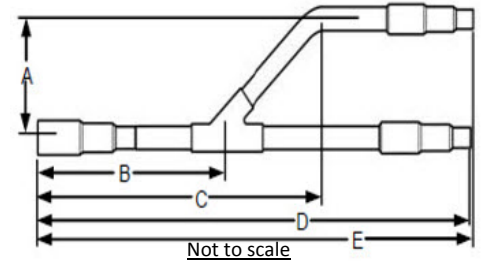

**Notes:**

1. Each Y-Branch kit comes with insulation for the following piping components - liquid, vapor line low and vapor line high.
2. LG branch fittings must be used. Field supplied branch fittings are not permitted.
3. Kit components must be kept dry and free of debris before installation.
4. Must follow installation instructions in the applicable LG installation manual.

Date: 7/24/2023	For: File	Resubmit
PO No.:	Approval	Other _____

Architect: Lewis Architects and Engineers GC: TBD

Engr: Lewis Architects and Engineers Mech: Comfort Systems USA

Rep: Airetech Corporation (Company) Nick Moore (Project Manager)

## Indoor Y-Branch Kits Multi V™ 3 Pipe



### Insulation<sup>1</sup> Properties:

Material	Polyolefin Foam
UL94 Flame Classification	HF-1

### Fitting Properties:

Material	Copper
Design Pressure	551 PSIG

Y-Branch Connection Diameters (in, ID)										
Model	Y-Branch Type	Port Identifier								
		1	2	3	4	5	6	7	8	9
ARBLB01621	Liquid	-	1/4	3/8	3/8	1/4	-	3/8	1/4	-
	Vapor Line Low	-	5/8	1/2	1/2	5/8	-	1/2	5/8	-
	Vapor Line High	3/8	5/8	1/2	1/2	5/8	3/8	1/2	5/8	3/8
ARBLB03321	Liquid	1/2	3/8	-	3/8	1/2	1/4	3/8	1/2	1/4
	Vapor Line Low	1	7/8	3/4	5/8	3/4	1/2	5/8	3/4	1/2
	Vapor Line High	3/4	1	7/8	7/8	3/4	5/8	7/8	3/4	5/8
ARBLB07121	Liquid	1/2	3/4	5/8	5/8	3/4	1/2	5/8	3/4	1/2
	Vapor Line Low	1-1/4	1-1/8	-	7/8	3/4	5/8	3/4	5/8	1/2
	Vapor Line High	1-1/8	1	-	7/8	1	3/4	7/8	1	3/4
ARBLB14521	Liquid	5/8	7/8	3/4	7/8	3/4	5/8	3/4	5/8	1/2
	Vapor Line Low	1-3/8	1-1/2	1-5/8	1-1/2	1-3/8	1-1/8	1-3/8	1-1/8	7/8
	Vapor Line High	1-1/8	1-3/8	1-1/4	1-1/8	1-1/4	1	1-1/8	1-1/4	1

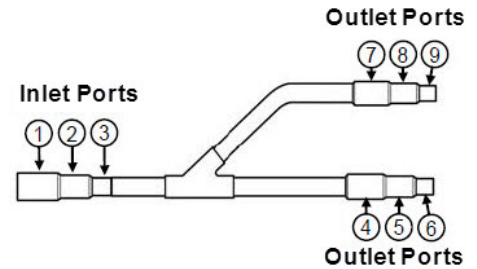

Reducer Diameters (in)						
Model	Qty/Kit	Reducer Type	10	11	12	Length
ARBLB01621	2	Liquid	1/2 ID	3/8 OD	-	2-3/4
		Vapor Line Low	3/4 ID	5/8 OD	-	2-3/4
		Vapor Line High	-	-	-	-
ARBLB03321	5	Liquid	-	-	-	-
			7/8 ID	3/4 OD	-	2-3/4
			1 ID	7/8 ID	3/4 OD	4-11/32
		Vapor Line Low	1-1/8 ID	1 OD	-	3-5/32
			5/8 OD	1/2 ID	-	2-3/4
Vapor Line High	5/8 OD	1/2 ID	3/8 ID	4-11/32		
	1/2 OD	3/8 ID	-	2-3/4		
ARBLB07121	8	Liquid	1/2 OD	3/8 ID	1/4 ID	4-11/32
			1-1/8 ID	7/8 ID	3/4 OD	4-23/32
			1-1/4 ID	1-1/8 ID	7/8 OD	4-23/32
		Vapor Line Low	1-3/8 ID	1-1/4 OD	-	3-17/32
			1/2 OD	3/8 ID	-	2-3/4
		Vapor Line High	3/4 OD	5/8 ID	-	2-3/4
			3/4 OD	5/8 ID	1/2 ID	4-11/32
ARBLB14521	12	Liquid	1/2 OD	3/8 ID	1/4 ID	4-11/32
			5/8 OD	1/2 ID	3/8 ID	4-11/32
			7/8 ID	3/4 OD	-	3-5/32
			5/8 OD	1/2 ID	-	2-3/4
			7/8 OD	3/4 ID	5/8 ID	4-23/32
			1-1/8 OD	7/8 ID	3/4 ID	4-23/32
		Vapor Line Low	1-5/8 ID	1-1/2 ID	1-3/8 OD	5-1/8
			1-5/8 ID	1-1/2 OD	-	3-17/32
			3/4 OD	5/8 ID	1/2 ID	4-11/32
		Vapor Line High	1/2 OD	3/8 ID	-	2-3/4
			1 OD	7/8 ID	-	3-5/32
			1 OD	7/8 ID	3/4 ID	4-23/32

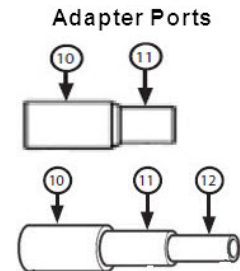

# Indoor Y-Branch Kits

## Multi V™ 3 Pipe



Tag #: \_\_\_\_\_

Date: 7/24/2023

PO No.: \_\_\_\_\_

Y-Branch Dimensions <sup>2</sup> (in)						
Model	Y-Branch Type	A	B	C	D	E
ARBLB01621	Liquid	2-29/32	6-9/16	8-1/32	11-1/16	11-1/2
	Vapor Line Low	2-29/32	4-1/2	7-31/32	11-1/16	11-1/2
	Vapor Line High	2-29/32	6-3/32	9-7/16	13-13/16	14-21/32
ARBLB03321	Liquid	2-29/32	4-1/2	8-1/32	12-5/8	13-1/16
	Vapor Line Low	3-9/32	6-29/32	10-7/8	15-11/32	16-1/4
	Vapor Line High	3-25/32	7-3/32	11-3/8	16-9/16	17-15/32
ARBLB07121	Liquid	3-9/32	6-1/8	10-1/32	14-9/32	15-1/2
	Vapor Line Low	3-25/32	5-1/2	10	14-13/16	15-29/32
	Vapor Line High	3-25/32	5-1/2	10-3/32	15	16-3/32
ARBLB14521	Liquid	3-25/32	7-3/32	11-11/16	16-3/8	17-15/32
	Vapor Line Low	4-29/32	7-7/8	13-23/32	18-17/32	20-11/32
	Vapor Line High	4-3/8	7-7/16	12-3/4	17-27/32	19-11/32

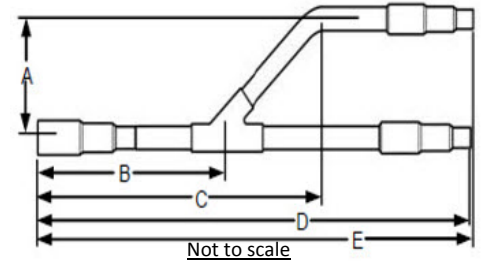

**Notes:**

1. Each Y-Branch kit comes with insulation for the following piping components - liquid, vapor line low and vapor line high.
2. LG branch fittings must be used. Field supplied branch fittings are not permitted.
3. Kit components must be kept dry and free of debris before installation.
4. Must follow installation instructions in the applicable LG installation manual.

Date: 7/24/2023

For: File Resubmit

PO No.:

Approval Other \_\_\_\_\_

Architect: Lewis Architects and Engineers

GC: TBD

Engr: Lewis Architects and Engineers

Mech: Comfort Systems USA

Rep: Airetech Corporation  
(Company)

Nick Moore  
(Project Manager)

## Indoor Y-Branch Kits

### Multi V™ 2 Pipe



#### Fitting Properties:

Material	Copper
Design Pressure	551 PSIG

#### Insulation<sup>1</sup> Properties:

Material	Polyolefin Foam
UL94 Flame Classification	HF-1

Y-Branch Connection Diameters (in, ID)										
Model	Y-Branch Type	Port Identifier								
		1	2	3	4	5	6	7	8	9
ARBLN01621	Liquid	-	1/4	3/8	3/8	1/4	-	3/8	1/4	-
	Vapor	-	5/8	1/2	1/2	5/8	-	1/2	5/8	-
ARBLN03321	Liquid	-	1/2	3/8	3/8	1/2	1/4	3/8	1/2	1/4
	Vapor	1	7/8	3/4	5/8	3/4	1/2	5/8	3/4	1/2
ARBLN07121	Liquid	1/2	3/4	5/8	5/8	3/4	1/2	5/8	3/4	1/2
	Vapor	-	1-1/4	1-1/8	7/8	3/4	5/8	3/4	5/8	1/2
ARBLN14521	Liquid	5/8	7/8	3/4	7/8	3/4	5/8	3/4	5/8	1/2
	Vapor	1-3/8	1-1/2	1-5/8	1-1/2	1-3/8	1-1/8	1-3/8	1-1/8	7/8

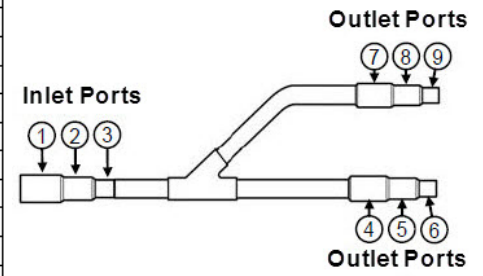

Not to scale

Reducer Diameters (in)						
Model	Qty/Kit	Reducer Type	10	11	12	Length
ARBLN01621	2	Liquid	1/2 ID	3/8 OD	-	2-3/4
		Vapor	3/4 ID	5/8 OD	-	2-3/4
ARBLN03321	3	Liquid	-	-	-	-
		Vapor	1-1/8 ID	1 OD	-	3-5/32
			7/8 ID	3/4 OD	-	2-3/4
ARBLN07121	5	Liquid	1 ID	7/8 ID	3/4 OD	4-11/32
			1/2 OD	3/8 ID	1/4 ID	4-11/32
		Vapor	1/2 OD	3/8 ID	-	2-3/4
			1-3/8 ID	1-1/4 OD	-	3-17/32
			1-1/4 ID	1-1/8 ID	7/8 OD	4-23/32
ARBLN14521	8	Liquid	1-1/8 ID	7/8 ID	3/4 OD	4-23/32
			7/8 ID	3/4 OD	-	3-5/32
			5/8 OD	1/2 ID	3/8 ID	4-11/32
			1/2 OD	3/8 ID	1/4 ID	4-11/32
		Vapor	7/8 OD	3/4 ID	5/8 ID	4-23/32
			1-5/8 ID	1-1/2 OD	-	3-17/32
			1-5/8 ID	1-1/2 ID	1-3/8 OD	5-1/8
			5/8 OD	1/2 ID	-	2-3/4
1-1/8 OD	7/8 ID	3/4 ID	4-23/32			

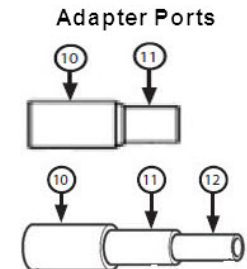

Y-Branch Dimensions <sup>2</sup> (in)						
Model	Y-Branch Type	A	B	C	D	E
ARBLN01621	Liquid	2-29/32	6-9/16	8	11-1/16	11-1/2
	Vapor	2-29/32	4-1/2	8	11-1/16	11-1/2
ARBLN03321	Liquid	2-29/32	4-1/2	8	12-5/8	13-1/16
	Vapor	3-9/32	6-29/32	10-29/32	15-11/32	16-1/4
ARBLN07121	Liquid	3-9/32	6-1/8	10	14-5/8	15-1/2
	Vapor	3-25/32	5-1/2	10	14-13/16	15-29/32
ARBLN14521	Liquid	3-25/32	7-3/32	11-7/8	16-3/8	17-15/32
	Vapor	4-15/16	7-29/32	13-7/8	18-17/32	20-11/32

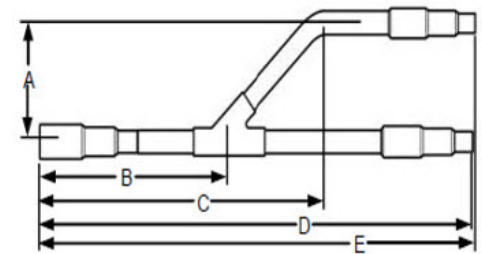

#### Notes:

- Each Y-Branch kit comes with insulation for the following piping components – liquid and vapor.
- LG branch fittings must be used. Field supplied branch fittings are not permitted.
- Kit components must be kept dry and free of debris before installation.
- Must follow installation instructions in the applicable LG installation manual.

Date: 7/24/2023  
 PO No.:

For:  File  Resubmit  
 Approval  Other \_\_\_\_\_

Architect: Lewis Architects and Engineers

GC: TBD

Engr: Lewis Architects and Engineers

Mech: Comfort Systems USA

Rep: Airetech Corporation  
 (Company)

Nick Moore  
 (Project Manager)

## Outdoor Y-Branch Kits

### Multi V™ III Heat Recovery



#### Insulation<sup>1</sup> Properties:

Material	Polyolefin Foam
UL94 Flame Classification	HF-1

#### Fitting Properties:

Material	Copper
Design Pressure	551 PSIG

Y-Branch Connection Diameters (in, ID)										
Model	Y-Branch Type	Port Identifier								
		1	2	3	4	5	6	7	8	9
ARCNB21	Liquid	-	3/4	5/8	1/2	5/8	3/8	1/2	5/8	-
	Vapor Line Low	1-1/8	1-1/4	1-3/8	7/8	1-1/8	-	1-1/8	-	-
	Vapor Line High	1-1/8	1-3/8	1-1/4	1-1/8	1-1/4	1	1-1/8	1-1/4	1
ARCNB31	Liquid	-	7/8	3/4	3/4	-	-	5/8	1/2	-
	Vapor Line Low	1-1/2	1-5/8	1-3/8	1-3/8	-	-	1-1/8	-	-
	Vapor Line High	1-3/8	1-1/2	1-5/8	1-1/2	1-3/8	1-1/8	1-3/8	1-1/8	7/8

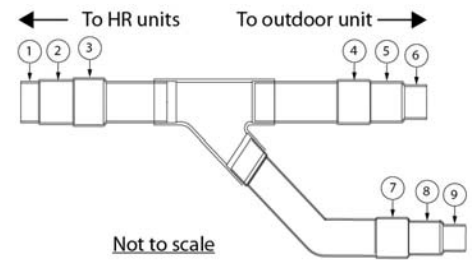

Reducer Diameters (in)							
Y-Branch	Qty/Kit	Reducer Type	10	11	12	13	Length
ARCNB21	7	Liquid	7/8 ID	3/4 OD	-	-	2-3/4
			5/8 OD	-	1/2 ID	3/8 ID	4-3/8
		Vapor Line Low	1-5/8 ID	1-1/2 ID	-	1-3/8 OD	5-1/8
			1-1/8 OD	-	7/8 ID	3/4 ID	4-3/4
		Vapor Line High	1 OD	7/8 ID	-	-	3-1/4
			1 OD	-	7/8 ID	3/4 ID	4-3/4
ARCNB31	6	Liquid	3/4 OD	-	5/8 ID	1/2 ID	4-3/8
			1/2 OD	-	3/8 ID	1/4 ID	4-3/8
		Vapor Line Low	1-5/8 ID	-	1-3/8 OD	-	4-7/8
			1-1/8 OD	-	7/8 ID	3/4 ID	4-3/4
		Vapor Line High	7/8 OD	-	3/4 ID	5/8 ID	4-3/4
			1-1/8 OD	-	7/8 ID	3/4 ID	4-3/4

#### Adapter Ports

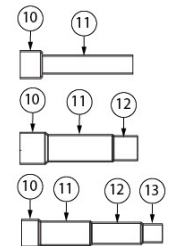

Y-Branch Dimensions <sup>2</sup> (in)				
Model	Y-Branch Type	A	B	C
ARCNB21	Liquid	3-1/4	12-3/8	13-1/16
	Vapor Line Low	4-3/8	16-1/16	16-3/8
	Vapor Line High	4-3/8	17-7/8	19-5/16
ARCNB31	Liquid	3-1/4	11-1/16	13-1/8
	Vapor Line Low	4-3/8	13-7/8	16
	Vapor Line High	4-15/16	18-9/16	20-3/8

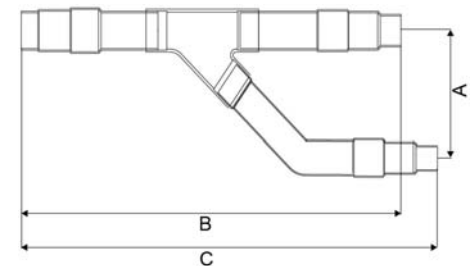

#### Notes:

- Each Y-Branch kit comes with insulation for the following piping components - liquid, vapor line low and vapor line high.
- LG branch fittings must be used. Field supplied branch fittings are not permitted.
- Kit components must be kept dry and free of debris before installation.
- Must follow installation instructions in the applicable LG installation manual.

## ***Improved Unibody Design Minimizes Leaks.***

### **Flare and ODS Connection Ball Valves for use with VRF Systems**

- Offered in both flare connections and ODS copper tube connections
- Superior Uni-body design eliminates leak points
- Full port design
- Design pressure/Maximum abnormal pressure (DP/MAP): 800 PSIG
- Offered with optional fully assembled insulation wrap
- Each ball valve is factory tested under pressure
- Equipped with access fitting for refrigerant service
- Forged brass body and seal cap
- Uses polytetrafluoroethylene (PTFE) seals and gaskets
- Seal cap design permits valve operation without removal of seal cap
- Sizes available: 1/4", 3/8", 1/2", 5/8"
- Continuous operating temperature (COT): -40°F to 325°F (-40°C to 160°C)
- Contact factory or visit website for compatibility with CFC, HCFC, HFC, and HFO refrigerants and oils
- CRN 0C8195.5

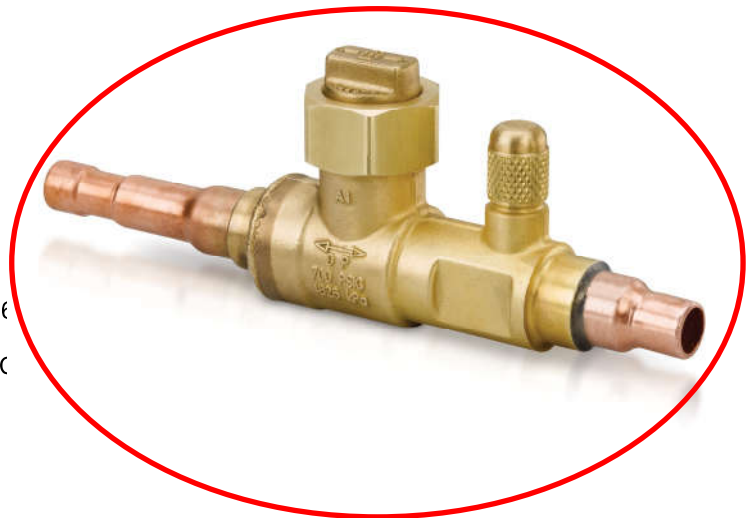

#### **A History of Quality and Innovation**

For nearly a century, Superior has been the world's leading provider of HVACR valves and accessories.

#### **Manufacturing Quality, Safety and Reliability**

Superior HVACR products are designed to meet the highest standards, and only quality materials are used. Careful assembly and detailed inspection of every part ensures top performance and durability. Superior is fully certified to the stringent requirements of ISO 9001, which increase manufacturing efficiency and reliability.

#### **Your Valve Partner**

Our engineering team includes experts in product design and development as well as experts in the quality and compliance testing requirements needed to create custom valves to meet your unique applications. We know valves are a system-critical piece of your business and we're proud to provide you with American-made products and service you can trust.

## ODS x ODS Connection Valve

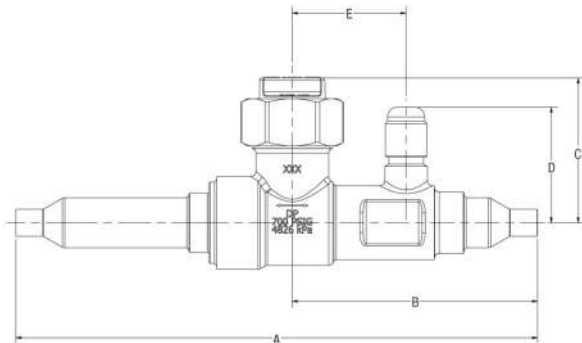

## Flare x Flare Connection Valve

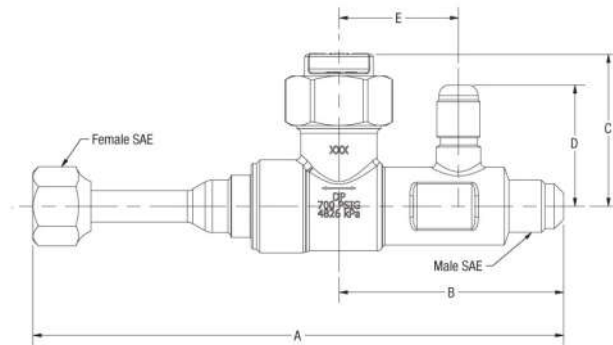

Part Number	Size (Inches)	Dimensions (Inches)					UPC	Weight (lbs.)
		A	B	C	D	E		
<b>Flare x Flare Connection</b>								
586WBS-8FL	1/2 M SAE x 1/2 F SAE	6.56	2.67	1.8	1.33	1.42	685768412892	1.00
586WBS-6FL	3/8 M SAE x 3/8 F SAE	6.38	2.67	1.8	1.33	1.42	685768412854	0.97
586WBS-4FL	1/4 M SAE x 1/4 F SAE	6.26	2.67	1.8	1.33	1.42	685768412809	0.93
586WBS-10FL	5/8 M SAE x 5/8 F SAE	6.72	2.67	1.8	1.33	1.42	685768412762	1.04
<b>Flare x Flare Connection, Factory Wrapped in Foam Insulation</b>								
586WBS-4FLSP	1/4 M SAE x 1/4 F SAE						685768412816	0.94
586WBS-10FLSP	5/8 M SAE x 5/8 F SAE						685768412779	1.04
586WBS-8FLSP	1/2 M SAE x 1/2 F SAE						685768412908	1.00
586WBS-6FLSP	3/8 M SAE x 3/8 F SAE						685768412861	0.95
<b>ODS x ODS Connection</b>								
586WBS-6SW	3/8 ODS x 3/8 ODS	6.50	3.06	1.8	1.33	1.42	685768412878	0.82
586WBS-4SW	1/4 ODS x 1/4 ODS	6.50	3.06	1.8	1.33	1.42	685768412823	0.88
586WBS-10SW	5/8 ODS x 5/8 ODS	6.50	3.06	1.8	1.33	1.42	685768412786	0.89
586WBS-8SW	1/2 ODS x 1/2 ODS	6.50	3.06	1.8	1.33	1.42	685768412915	0.88
<b>ODS x ODS Connection, Factory Wrapped Foam Insulation</b>								
586WBS-10SWSP	5/8 ODS x 5/8 ODS						685768412793	1.00
586WBS-8SWSP	1/2 ODS x 1/2 ODS						685768412922	0.85
586WBS-6SWSP	3/8 ODS x 3/8 ODS						685768412885	0.88
586WBS-4SWSP	1/4 ODS x 1/4 ODS						685768412830	0.86